

# Operation & Maintenance Manual

SEAM007209T

## D65EX-12 D65PX-12 BULLDOZER

SERIAL NUMBERS D65EX-65001 and up  
D65PX-65001

### WARNING

Unsafe use of this machine may cause serious injury or death. Operators and maintenance personnel must read this manual before operating or maintaining this machine. This manual should be kept near the machine for reference and periodically reviewed by all personnel who will come into contact with it.

### NOTICE

Komatsu has Operation & Maintenance Manuals written in some other languages. If a foreign language manual is necessary, contact your local distributor for availability.

# KOMATSU

CLICK HERE TO **DOWNLOAD** THE COMPLETE MANUAL

- Thank you very much for reading the preview of the manual.
- You can download the complete manual from: [www.heydownloads.com](http://www.heydownloads.com) by clicking the link below



- Please note: If there is no response to CLICKING the link, please download this PDF first and then click on it.

CLICK HERE TO **DOWNLOAD** THE COMPLETE MANUAL

# CONTENTS

## FOREWORD

FOREWORD .....	1-2
SAFETY INFORMATION .....	1-5
INTRODUCTION .....	1-7
FRONT/REAR, LEFT/RIGHT DIRECTIONS OF MACHINE .....	1-7
NECESSARY INFORMATION .....	1-8
MACHINE SERIAL NO. PLATE AND POSITION .....	1-8
ENGINE SERIAL NO. PLATE AND POSITION .....	1-8
POSITION OF SERVICE METER .....	1-9
TABLE OF ENTER SERIAL NO. AND DISTRIBUTOR .....	1-9

## SAFETY

SAFETY .....	2-2
SAFETY LABELS .....	2-4
POSITIONS OF SAFETY PICTOGRAMS .....	2-4
SAFETY LABELS .....	2-5
GENERAL PRECAUTIONS .....	2-8
PRECAUTIONS FOR OPERATION .....	2-17
STARTING ENGINE .....	2-17
OPERATION .....	2-19
TRANSPORTATION .....	2-23
BATTERY .....	2-24
TOWING .....	2-26
PRECAUTIONS FOR MAINTENANCE .....	2-27

## OPERATION

GENERAL VIEW .....	3-2
GENERAL VIEW OF MACHINE .....	3-2
GENERAL VIEW OF CONTROLS AND GAUGES .....	3-3
EXPLANATION OF COMPONENTS .....	3-6
MONITOR PANEL .....	3-6
GAUGE PANEL .....	3-10
SWITCHES .....	3-12

(9) Caution for engine running (09667-03001)



(10) Caution for approach when machine moving (09812-13000)



(11) Warning for ROPS (09620-30201)

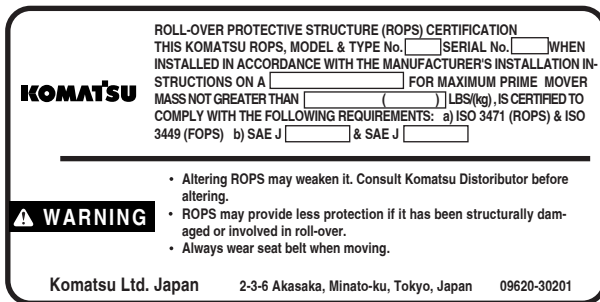

(12) Warning for battery (14X-98-11370)

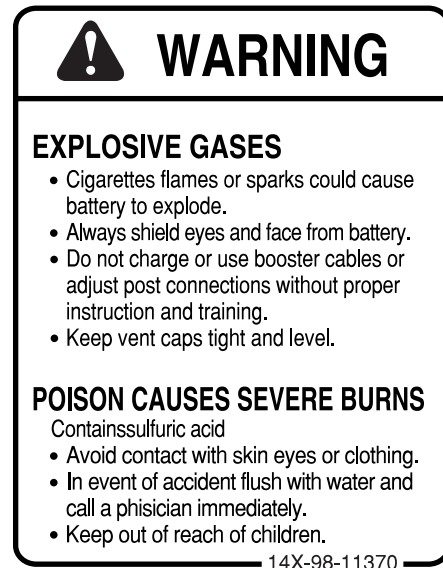

Safety label is attached on the battely.

# PRECAUTIONS FOR OPERATION

## STARTING ENGINE

If there is a warning tag hanging from the work equipment control lever, do not start the engine or touch the levers.

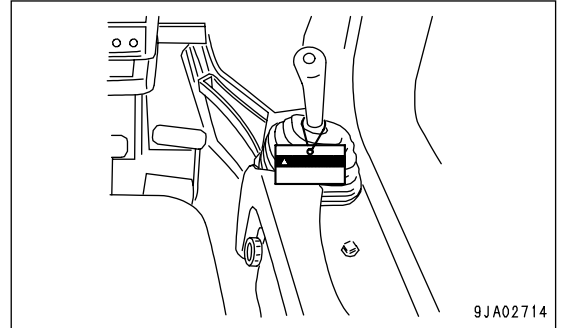

## CHECKS BEFORE STARTING ENGINE

Carry out the following checks before starting the engine at the beginning of the day's work.

- Remove all dirt from the surface of the window glass to ensure a good view.
- Remove all dirt from the surface of the lens of the front lamps and working lamps, and check that they light up correctly.
- Check the coolant level, fuel level, and oil level in engine oil pan, check for clogging of the air cleaner, and check for damage to the electric wiring.
- Adjust the operator's seat to a position where it is easy to carry out operations, and check that there is no damage or wear to the seat belt or mounting clamps.
- Check that the gauges work properly, check the angle of the lights and working lamps, and check that the control levers are all at the neutral position.
- Check that there are no persons or obstacles above, below, or in the area around the machine.

# PRECAUTIONS FOR MAINTENENCE

## WARNING TAG

- Always attach the "DO NOT OPERATE" warning tag to the work equipment control lever in the operator's cab to alert others that you are performing service or maintenance on the machine. Attach additional warning tags around the machine if necessary.

Warning tag Part No. 09963-03001

Keep this warning tag in the tool box while it is not used. If there is not the tool box, keep the tag in the operation manual pocket.

- If others start the engine, or touch or operate the work equipment control lever while you are performing service or maintenance, you could suffer serious injury or property damage.

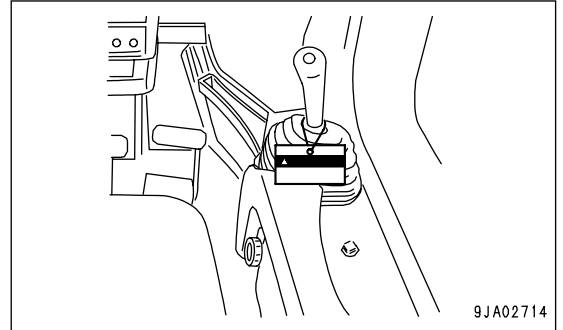

## KEEP WORK PLACE CLEAN AND TIDY

Do not leave hammers or other tools lying around in the work place. Wipe up all grease, oil, or other substances that will cause you to slip. Always keep the work place clean and tidy to enable you to carry out operations safely. If the work place is not kept clean and tidy, there is the danger that you will trip, slip, or fall over and injure yourself.

## APPOINT LEADER WHEN WORKING WITH OTHERS

When repairing the machine or when removing and installing the work equipment, appoint a leader and follow his instructions during the operation.

When working with others, misunderstandings between workers can lead to serious accidents.

Machine equipped with canopy  
 Monitor panel specification

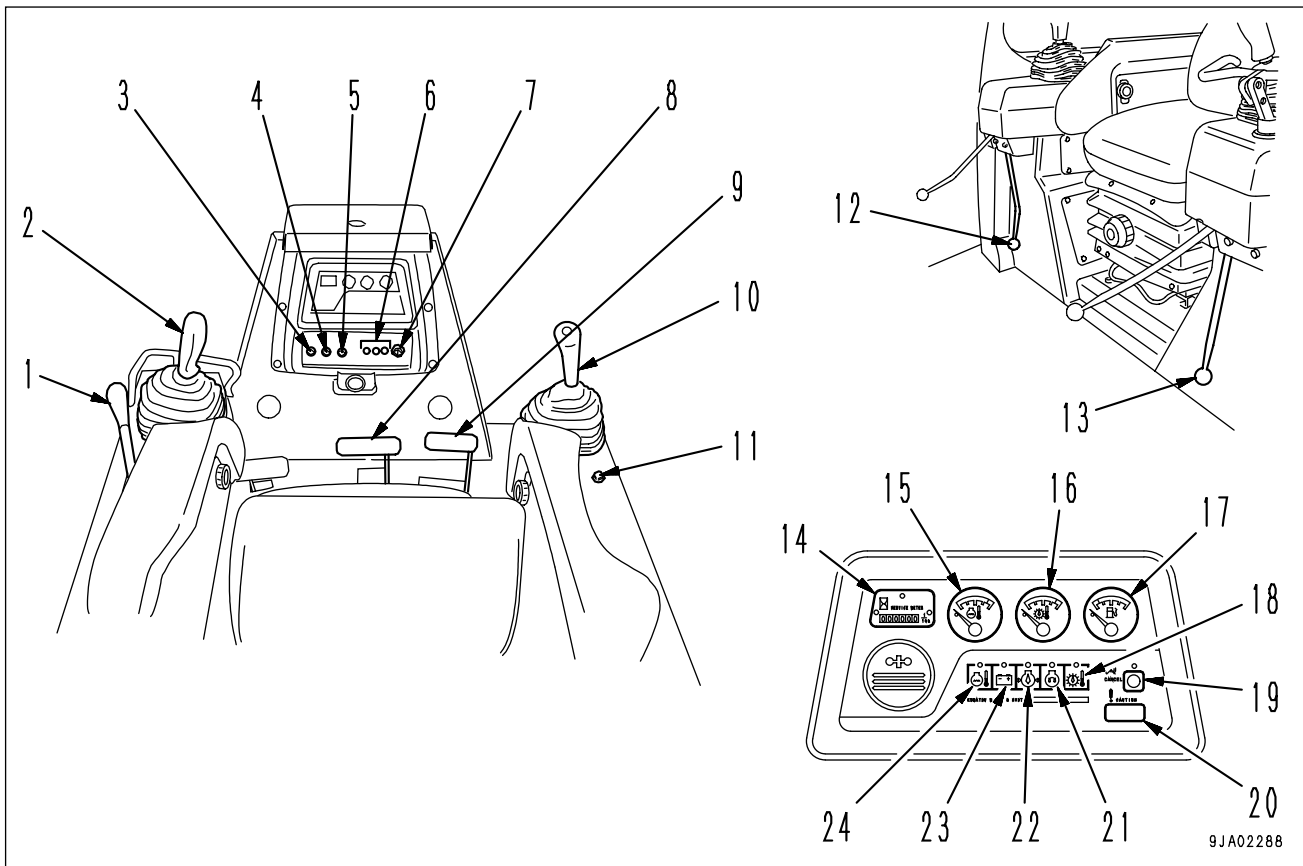

- |  |  |
|--|--|
| (1) Fuel control lever                           | (13) Brake lock lever                          |
| (2) Steering, directional and gear shift lever   | (14) Service meter                             |
| (3) Head lamp switch                             | (15) Engine water temperature gauge            |
| (4) Rear lamp switch                             | (16) Transmission oil temperature gauge        |
| (5) Glow switch                                  | (17) Fuel gauge                                |
| (6) Speed range display lamp                     | (18) Transmission oil temperature caution lamp |
| (7) Starting switch                              | (19) Monitor caution cancel switch             |
| (8) Brake pedal                                  | (20) Monitor caution lamp                      |
| (9) Decelerator pedal                            | (21) Glow signal lamp                          |
| (10) Blade control lever                         | (22) Engine oil pressure caution lamp          |
| (11) Horn switch                                 | (23) Charge lamp                               |
| (12) Safety lock lever (for blade control lever) | (24) Engine water temperature caution lamp     |

## HORN SWITCH

The horn sounds when the button (3) at the rear of the blade control lever at the right side of the operator's seat is pressed.

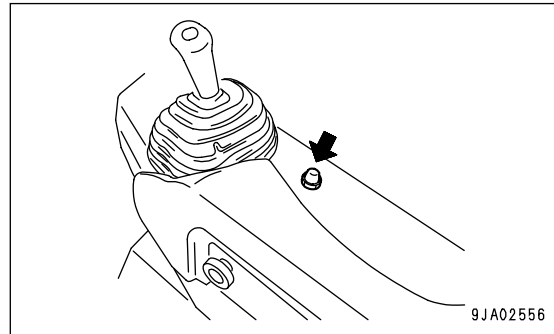

## HEAD LAMP SWITCH

This switch (4) lights up the head lamps.

OFF position: Lamps are out  
ON position: Lamps light up

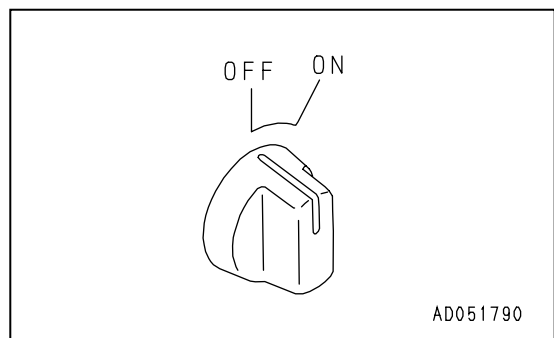

## REAR LAMP SWITCH

This switch (5) lights up the rear lamps.

OFF position: Lamps are out  
ON position: Lamps light up

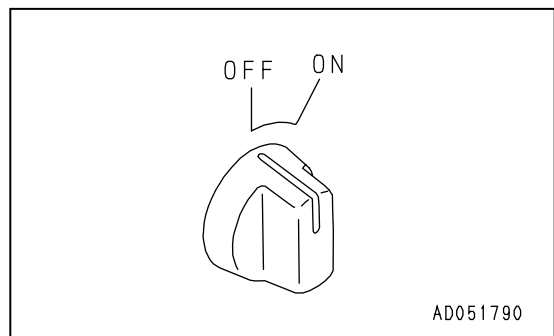

● Tilting control

- (e) LEFT TILT
- (f) RIGHT TILT

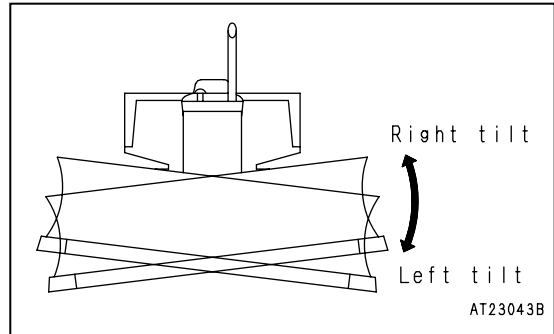
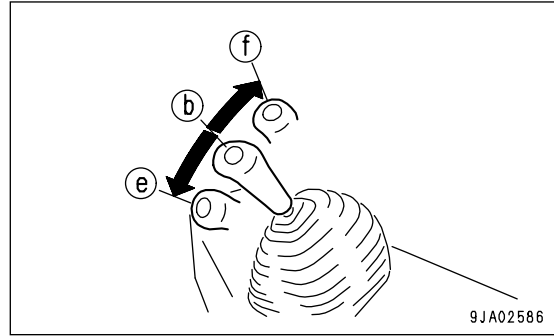

● Pitch control

- (b) HOLD: Blade is stopped and held in this position.
  - (e) REAR PITCH:Min. digging angle
  - (f) FORWARD PITCH:Max. digging angle
- First set the lever to the neutral position, then keep switch (A) in the center of the knob pushed down and carry out the tilt operation to change the cutting angle of the blade.

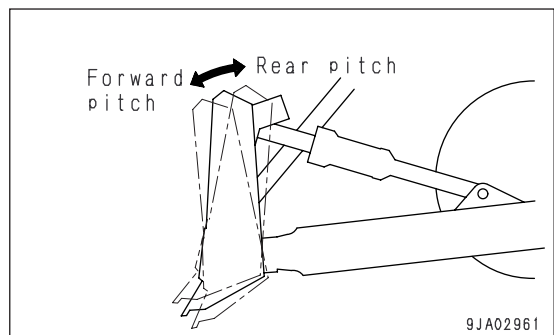
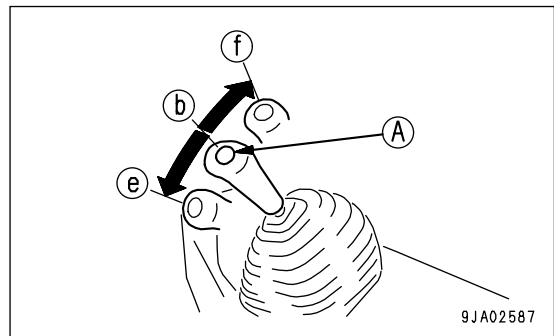

## BLOWER SWITCH

This switch (3) acts as the wind flow control switch and main switch when cooling or heating.

- The air flow can be set to three stages:  
1 (LOW) → 2 (MEDIUM) → 3 (HIGH).
- If the switch is set to 0, the power is switched off and the air conditioner stops.

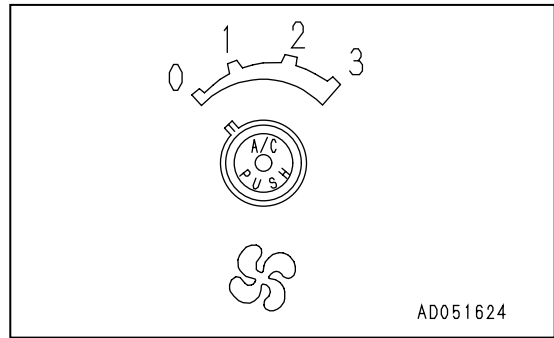

## TEMPERATURE CONTROL LEVER

This lever (4) is used to control the temperature for cooling or heating.

- When the temperature control lever is moved to the right, the temperature of the air coming from the vents becomes lower. (The water valve is closed and the heating function is stopped.)
- When the temperature control lever is moved to the left, the temperature of the air coming from the vents becomes higher. (The water valve is opened and the heating function is started.)

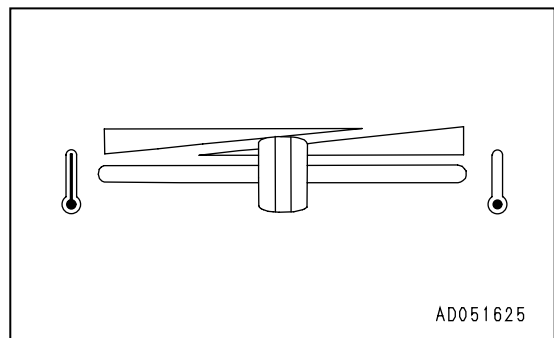

## CHECK BEFORE STARTING

Always carry out the items of the checks in this section before starting the engine each day.

### CHECK COOLANT LEVEL, ADD WATER

#### WARNING

- Do not open the radiator cap unless necessary. When checking the coolant, always wait for the engine to cool down and check the sub tank.
- Immediately after the engine is stopped, the coolant is at a high temperature and the radiator is under high internal pressure. If the cap is removed to drain the coolant in this condition, there is a hazard of burns. Wait for the temperature to go down, then turn the cap slowly to release the pressure before removing it.

1. Open the engine side cover on the left side of the chassis, and check that the coolant is between the FULL and LOW marks on sub-tank (1). If the water level is low, add water to the FULL level through the water filler port in sub-tank (1).

#### REMARK

In summer, the coolant may overflow from the sub-tank drain hose. This is no problem. It occurs because too much coolant has been added.

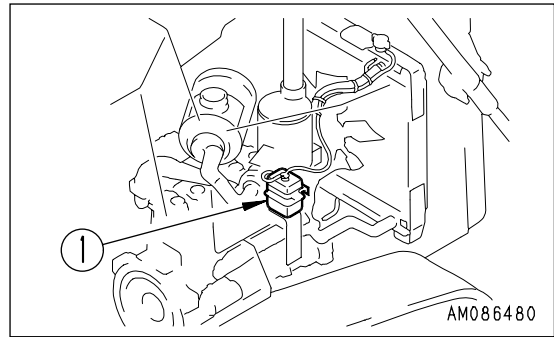

2. After adding water, tighten the cap securely.
3. If the sub-tank is empty, check for leakage of water, then add water to the radiator and sub-tank.
4. After adding water, close the engine side cover.

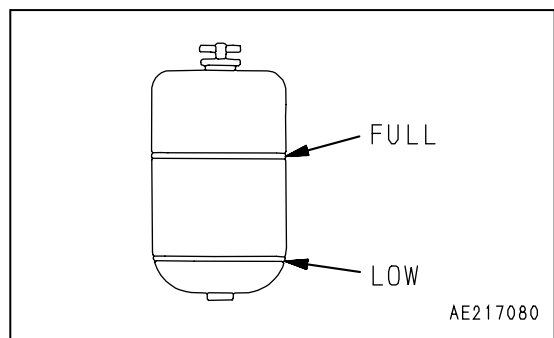

**CHECK FOR WATER AND SEDIMENT IN WATER SEPARATOR, DRAIN WATER**

(If equipped)

The water separator separates water mixed in the fuel. If float (2) is at or above red line (1), drain the water according to the following procedure.

1. Loosen drain plug (3) and drain the accumulated water until the float reaches the bottom.
2. Tighten drain plug (3).
3. If the air is sucked into fuel line when draining and water, be sure to bleed air in the same manner as for the fuel filter. See "REPLACE FUEL FILTER CARTRIDGE (PAGE 4-52)".

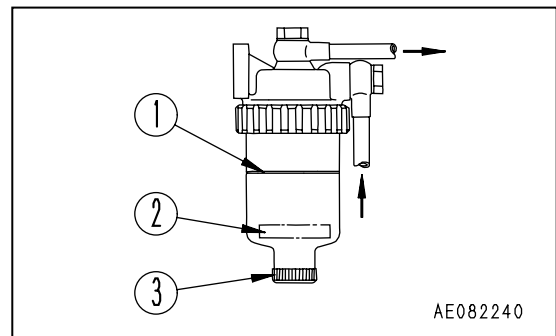

**MANUAL PREHEATING**

- Turn glow switch (3) to position I or II.  
Lamp (4) lights up during the preheating operation.  
When the preheating is completed, release the switch.  
The key will then return automatically to the following position.  
From position I, it will return to AUTO  
From position II, it will return to OFF

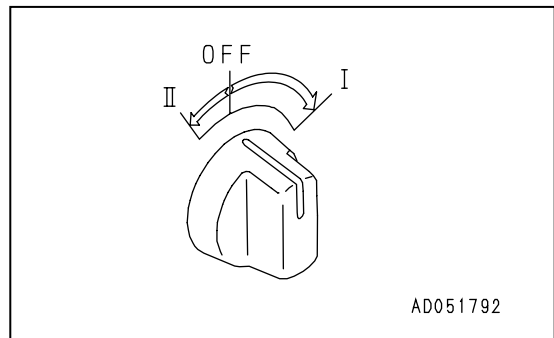

The preheating times are as shown below.

Ambient temperature	Preheat time
0°C to -5°C (32°F to 23°F)	-
-5°C to -10°C (23°F to 14°F)	15 seconds
-10°C to -20°C (14°F to -4°F)	30 seconds
-20°C to -30°C (-4°F to -22°F)	45 seconds

If the preheating time is too long or too short, the engine will not start easily. Observe the correct preheating time.

- When the preheating is completed, turn the key in starting switch (2) to the START position to start the engine.

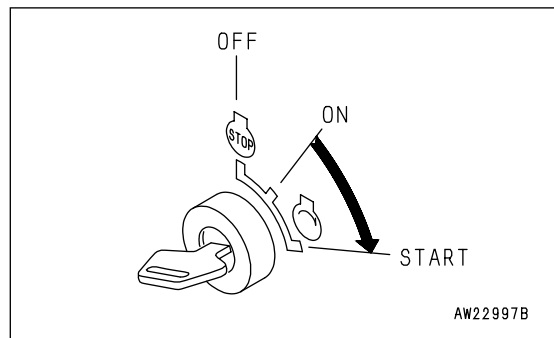

- When the engine starts, release the key in starting switch (2). The key will return automatically to the ON position.

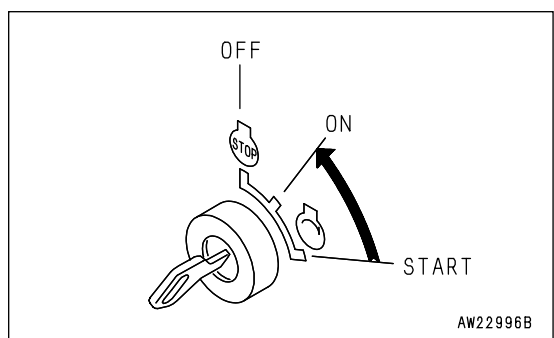

- Continue idling for 10 seconds after the engine starts. During this time, do not operate the control levers or fuel control lever.

CLICK HERE TO **DOWNLOAD** THE COMPLETE MANUAL

- Thank you very much for reading the preview of the manual.
- You can download the complete manual from: [www.heydownloads.com](http://www.heydownloads.com) by clicking the link below



- Please note: If there is no response to CLICKING the link, please download this PDF first and then click on it.

CLICK HERE TO **DOWNLOAD** THE COMPLETE MANUAL

- Operate steering, directional and gear shift lever (4) to the desired position, and check that speed range display lamp (3) shows the correct position.

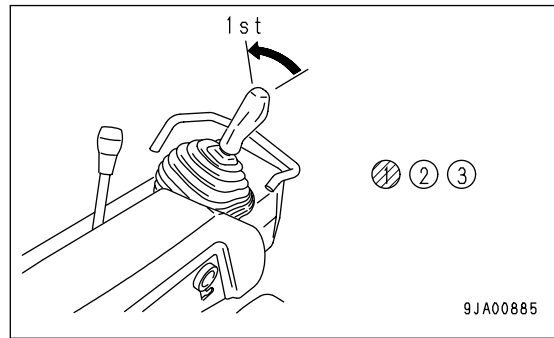

- Pull the safety lock lever (6) to the free position.

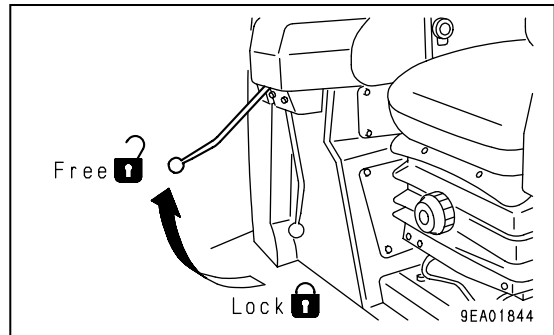

- Put blade control lever (5) in the RAISE position to raise the blade 40 to 50mm (1.6 to 2.0in) off the ground.

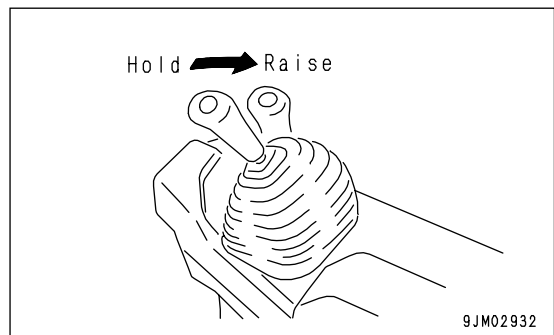

- Move steering, direction and gear shift lever (4) to the F (forward) or R (reverse) position to move the machine off.

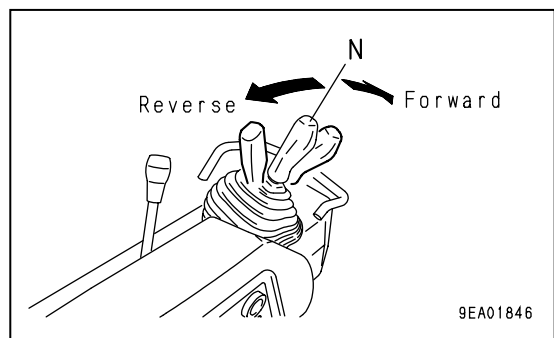

- Pull fuel control lever (7) to increase engine speed.

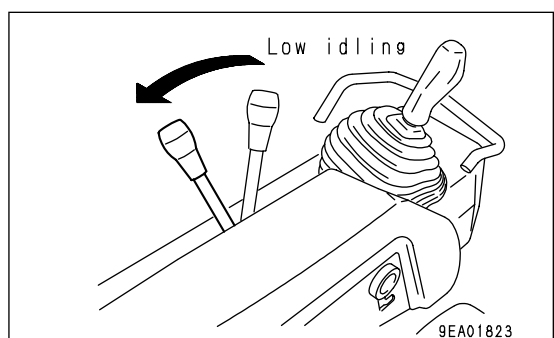

## PRECAUTIONS FOR OPERATION

### PERMISSIBLE WATER DEPTH

When operating in water, always keep the bottom of carrier roller (1) above the surface of the water. Also, be careful that the engine cooling fan will not come in contact with water. The fan can be damaged.

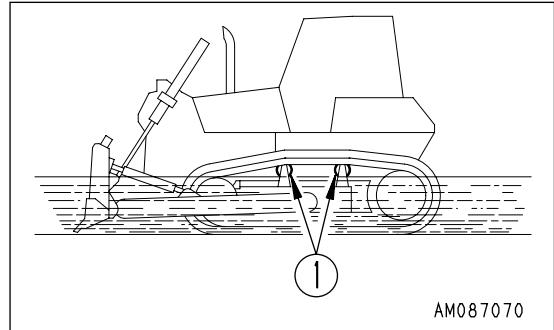

### PRECAUTIONS WHEN TRAVELING UP OR DOWN HILLS

#### USE ENGINE AS BRAKE

When going downhill, shift gear shift lever into low speed to run engine at slow speed and travel down slope using the engine as a brake.

Never coast down slope with the steering and directional lever in the N (neutral) position.

#### BRAKING WHEN TRAVELING DOWNHILL

While descending a slope using the engine as a brake, also apply the brakes.

Failure to brake may result in overrunning, causing engine trouble.

### PRECAUTIONS ON SLOPES

#### BE CAREFUL OF FUEL LEVEL

If the fuel level in the fuel tank becomes low when working on slopes, the engine may suck in air because of the angle of the machine or the swaying of the machine. If this makes the engine stop, so be careful not to let the fuel level in the fuel tank become too low.

#### PRECAUTIONS WHEN ENGINE STOPS ON SLOPES

If the engine stops while working or driving on a slope, the brake is applied automatically. Take care since the machine stops suddenly at this time.

### IT IS PROHIBITED TO KEEP THE DOOR OPEN DURING OPERATIONS

(Machine equipped with cab)

Always keep the door closed when traveling or carrying out operations.

If the door is open, there is danger of damage from obstacles or strong vibration.

## LOCKING

To prevent vandalism, there are locks at the following places. Places that can be locked with the starting switch key.

- Top cover at front of chassis (1)
- Right and left engine side cover (2)
- Battery inspection cover (3)
- Inspection cover for fuel tank drain valve (4)
- Cab door opener (5) (machines equipped with cab)
- Fuel tank filler cap (6)
- Hydraulic tank filler cap (7)

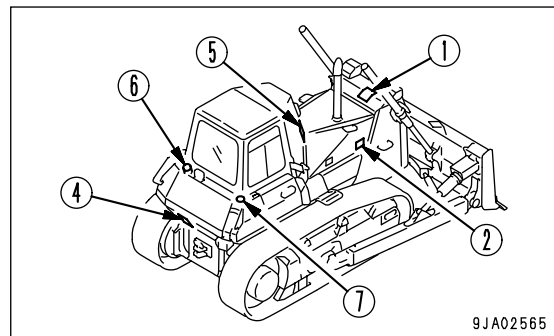
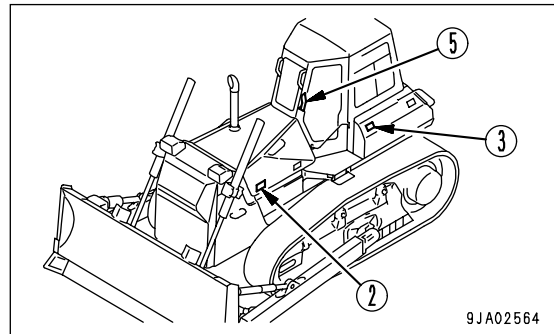

## UNLOADING

1. Perform loading and unloading on firm, level ground only. Maintain a safe distance from the edge of a road.

2. Properly apply the brakes on the trailer and put blocks under the tires to ensure that the trailer does not move. Then fix the ramps in line with the centers of the trailer and the machine.

Be sure that the two sides are at the same level as one another. Make the slope of the ramps a maximum of 15°. Set the distance between the ramps to match the center of the tracks.

3. Remove the chains or wire rope holding the machine.

4. Start the engine.  
Warm the engine up fully.

5. Set the safety lock lever to the FREE position.

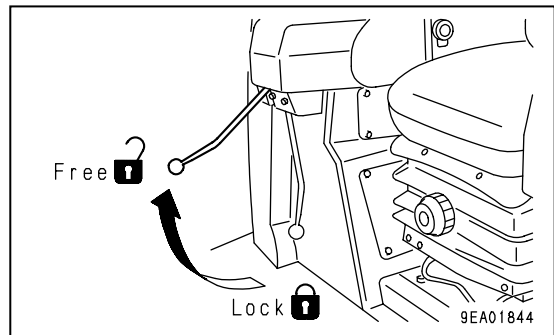
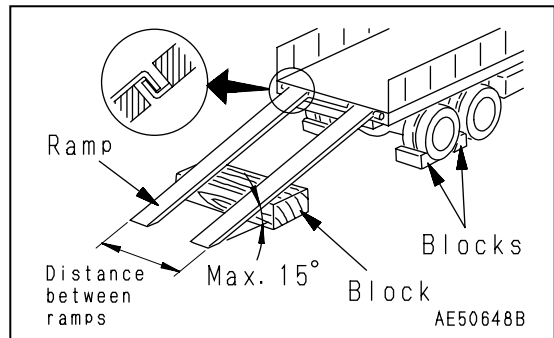

6. Set the brake lock lever to the FREE position.

7. Set the transmission in the 1st gear and run the engine at low idling speed.

8. Raise the blade.

9. Set the travel direction toward the ramps and drive slowly.

10. The center of gravity of the machine shifts suddenly at the border between the ramps and trailer, and the machine is unbalanced and becomes dangerous. Accordingly, pass the boarder slowly.

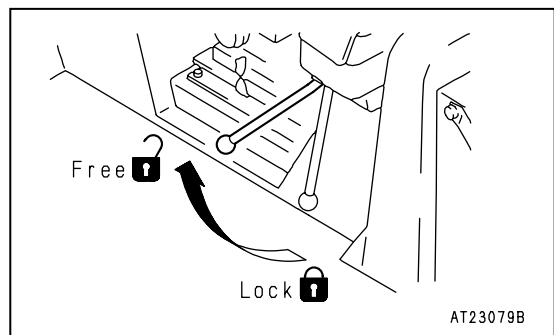

11. Drive down the ramps slowly and carefully until the machine leaves the ramps perfectly.

## STARTING ENGINE WITH BOOSTER CABLE

When starting the engine with a booster cable, do as follows:

### PRECAUTIONS WHEN CONNECTING AND DISCONNECTING BOOSTER CABLE

#### ⚠ WARNING

- When connecting the cables, never contact the positive (-) and negative (+) terminals.
- When starting the engine with a booster cable, always wear safety glasses and rubber gloves.
- Be careful not to let the normal machine and problem machine contact each other. This prevents sparks from generating near the battery which could ignite the hydrogen gas given off by the battery.
- Make sure that there is no mistaken in the booster cable connections. The final connection is to the engine block of the problem machine, but sparks will be generated when this is done, so connect to a place as far as possible from the battery.
- When disconnecting the booster cable, take care not to bring the clips in contact with each other or with the machine body.

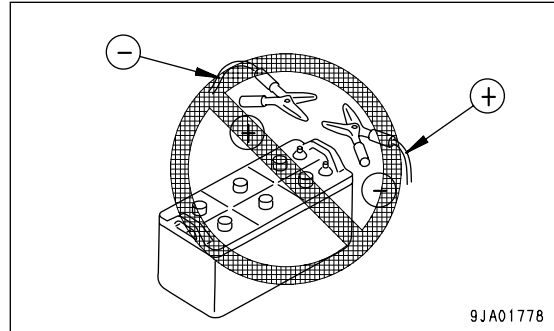

#### NOTICE

- The size of the booster cable and clip should be suitable for the battery size.
- The battery of the normal machine must be the same capacity as that of the engine to be started.
- Check the cables and clips for damage or corrosion.
- Make sure that the cables and clips are firmly connected.
- Check that the safety lock levers and brake lock levers of both machines are in the LOCK positions respectively.
- Check that each lever is in the neutral position.

### CONNECTING THE BOOSTER CABLE

Keep the starting switch of the normal machine and problem machine are both at the OFF position.

Connect the booster cable as follows, in the order of the numbers marked in the diagram.

1. Connect one clip of booster cable (A) to the positive (+) terminal of the problem machine.
2. Connect the other clip of booster cable (A) to the positive (+) terminal of the normal machine.
3. Connect one clip of booster cable (B) to the negative (-) terminal of the normal machine.
4. Connect the other clip of booster cable (B) to the engine block of the problem machine.

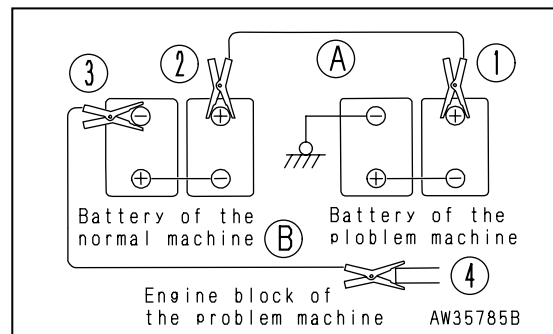

**DO NOT DROP THINGS INSIDE MACHINE:**

- When opening inspection windows or the oil filler port of the tank to carry out inspection, be careful not to drop nuts, bolts, or tools inside the machine.  
If such things are dropped inside the machine, it will cause damage and malfunction of the machine, and will lead to failure. If you drop anything inside the machine, always remove it immediately.
- Do not put unnecessary things in your pockets. Carry only things which are necessary for inspection.

**DUSTY WORKSITES:**

When working at dusty worksites, do as follows:

- Inspect the air cleaner clogging monitor frequently to see if the air cleaner is clogged.  
Clean the air cleaner element at a shorter interval than specified.
- Clean the radiator core frequently to avoid clogging.
- Clean and replace the fuel filter frequently.
- Clean electrical components, especially the starting motor and alternator, to avoid accumulation of dust.
- When inspecting or changing the oil, move the machine to a place that is free of dust to prevent dirt from getting into the oil.

**AVOID MIXING OILS:**

Never mix different kinds of oil. If a different type of oil has to be added, drain the old oil and replace all the oil with the new type of oil.

**PRECAUTIONS FOR OPENING AND CLOSING ENGINE SIDE COVER**

- Open the engine side cover all the way and ensure it is locked open before letting go.
- When standing on the track to open the engine side cover, bend at the knees and open the cover in a standing position to avoid back strain.
- Close the engine side cover before opening or closing the cab door.



**REMARK**

- When fuel sulphur content is less than 0.5%, change oil in the oil pan every periodic maintenance hours described in this manual.  
Change oil according to the following table if fuel sulphur content is above 0.5%.
- When starting the engine in an atmospheric temperature of lower than 0°C (32°F), be sure to use engine oil of SAE10W, SAE10W-30 and SAE15W-40, even though an atmospheric temperature goes up to 10°C (50°F) more or less in the day time.  
Use CE or CF class oil for the engine oil.
- Use API classification CD as engine oil and if API classification CC, reduce the engine oil change interval to half.
- There is no problem if single grade oil is mixed with multigrade oil (SAE10W-30, 15W-40), but be sure to add single grade oil that matches the temperature in the table.
- We recommend Komatsu genuine oil which has been specifically formulated and approved for use in engine and hydraulic work equipment applications.

Specified capacity: Total amount of oil including oil for components and oil in piping.

Refill capacity: Amount of oil needed to refill system during normal inspection and maintenance.

ASTM: American Society of Testing and Material

SAE: Society of Automotive Engineers

API: American Petroleum Institute

Fuel sulphur content	Charge interval of oil in engine oil pan
0.5 to 1.0%	1/2 of regular interval
Above 1.0%	1/4 of regular interval

7. Install the cleaned element and secure it with wing nut (5) and seal washer (4).  
If seal washer (4) or threads of wing nut (5) are damaged or have any defect, replace with new one.

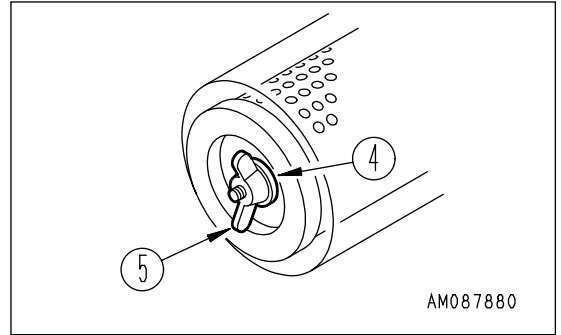

8. Remove the evacuator valve (11), clean with dry compressed air and then reinstall it.
9. Install the cover (3).
10. Press the button of dust indicator (1) to return the red piston to its original position.

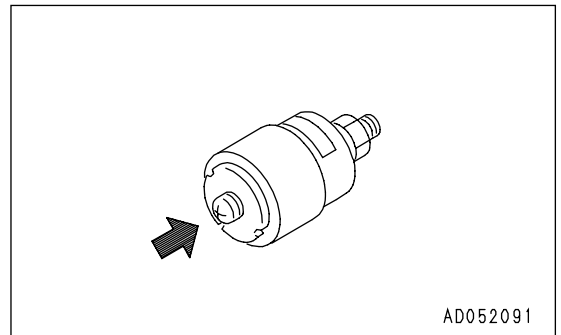

11. Close the left engine side cover.

**REPLACING ELEMENT**

1. Open the left engine side cover.
2. Loosen bolt (2), remove cover (3).
3. Remove the wing nut (4) and the seal washer (5), and take out the outer element (6).
4. Remove the snap ring (7), nut (8) and washer (9), and then take out the inner element (10).
5. To prevent dust from getting in, use a clean cloth or tape to cover the air connector (outlet side).
6. Clean the air cleaner housing interior, then remove the cover installed in Step 5.
7. Fit a new inner element (10) to the air connector and tighten with nut (8) and washer (9).

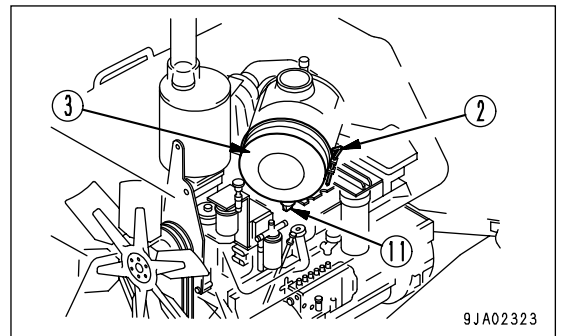

**NOTICE**

- The inner element (10) must not be cleaned and used again.  
When replacing the outer element (6), replace the inner element (10) at the same time.
- The nut (8), washer (9), snap ring (7), wing nut (4) and seal washer (5) must not be used again. replace them with new ones.

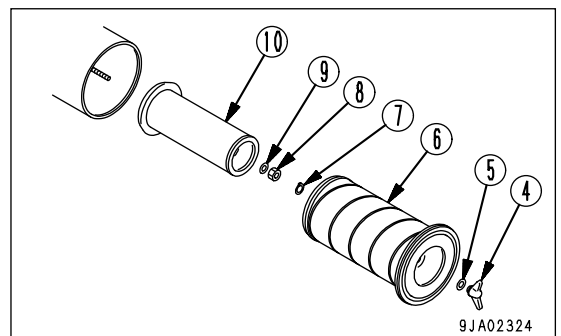

8. Install the snap ring (7).

## CLEAN, CHECK RADIATOR FINS

1. Remove bolts (1) (4 bolts).
2. Open the A side (hinge side) of the radiator mask. It opens approx. 10 mm (0.4 in).
3. Open the B side of the radiator mask.
4. Clean the radiator fins clogged with mud, dust and leaves with compressed air. Steam or water may be used instead of compressed air.

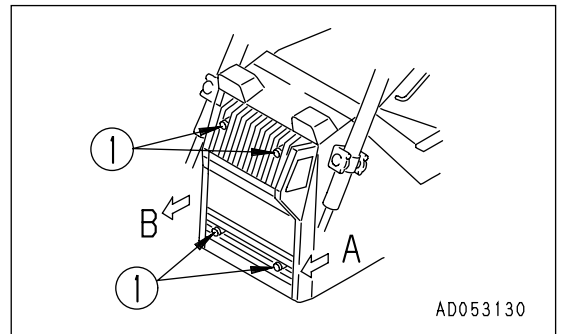

### REMARK

Check the rubber hose. If the hose is found to have cracks to be hardened by ageing, replace such hose with new one. Further, loosen hose clamp should also be checked.

5. When closing the radiator mask, always push in the A side first, then push in the B side, align the bolt holes, and tighten bolts (1).

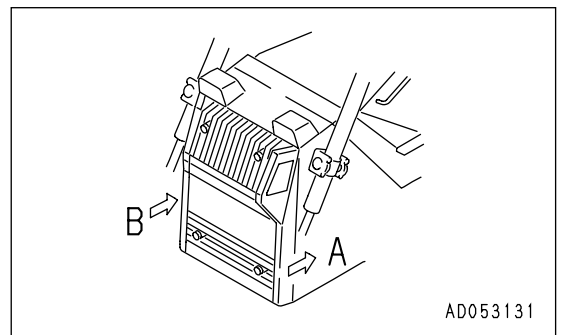

## EVERY 250 HOURS SERVICE

Maintenance for every 50 hours service should be carried out at the same time.

### LUBRICATING

1. Lower the blade to the ground, then stop the engine.
2. Using a grease pump, pump in grease through the grease fittings shown by arrows.
3. After greasing, wipe off any old grease that was pushed out.

### POWER TILTDOZER

- (1) Lift cylinder support yoke (4 places)
- (2) Lift cylinder support shaft (2 places)

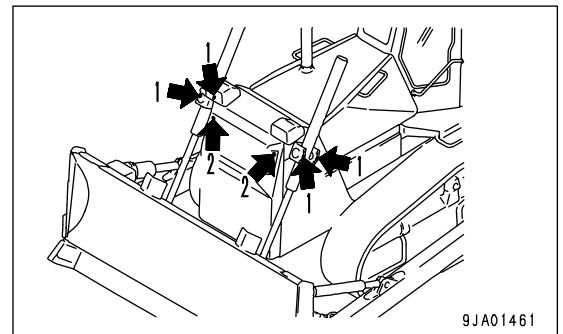

- (3) Lift cylinder ball joint (2 places)
- (4) Tilt cylinder ball joint (1 place)
- (5) Tilt brace ball joint (1 place)
- (6) Brace ball joint (2 places)
- (7) Tilt brace thread (1 place) (screw-adjustable)

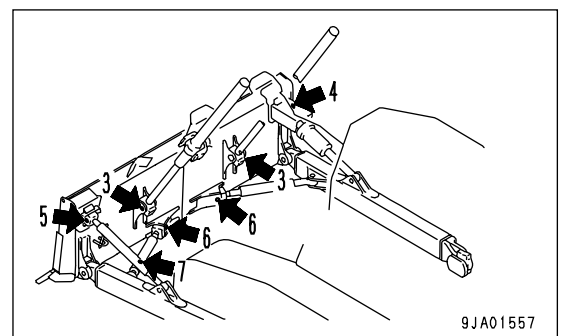

### POWER TILT-POWER PITCH DOZER

- (1) Lift cylinder support yoke (4 places)
- (2) Lift cylinder support shaft (2 places)

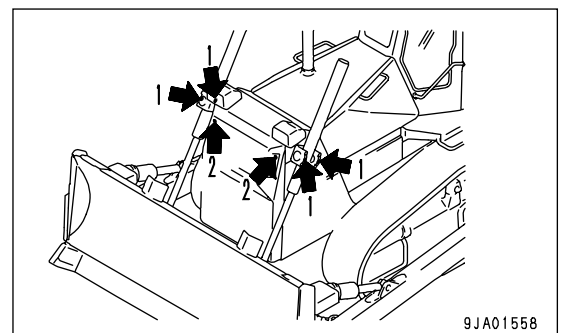

## METHOD OF USING AUTOMATIC AIR BLEED MECHANISM

(If equipped)

### WARNING

When cranking the engine, ensure no one is around the engine, as the engine may start.

### NOTICE

When the engine has run out of fuel, turn the starting switch key to the START position and rotate the starting motor for 15-20 seconds to crank the engine and bleed the air. Repeat this 2-3 times to bleed the air completely. The time taken to bleed the air is shorter when the fuel tank is full. Do not rotate the starting motor continuously for more than 20 seconds. Wait for 1-2 minutes before rotating it again.

It is possible to bleed the air from the fuel circuit simply by rotating the starting motor with the starting switch. Bleed the air as follows;

1. After replacing the filter cartridge, check that the fuel control lever is at the low idling position.

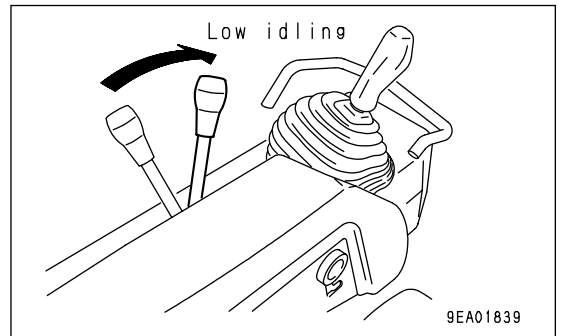

2. Set the brake lock lever to the LOCK position.

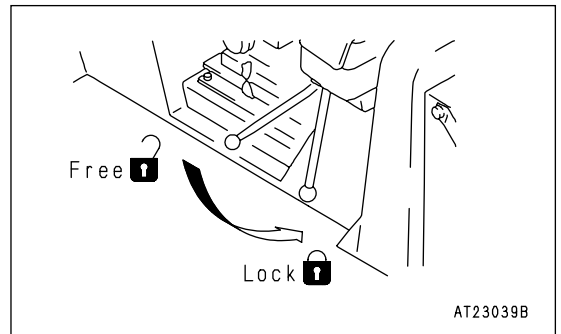

3. Turn the starting switch key to the START position and rotate the starting motor for 15-20 seconds to crank the engine and bleed the air.

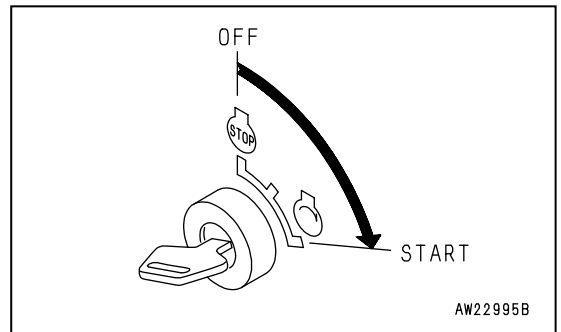

6. Remove seal (6) installed to the frame.

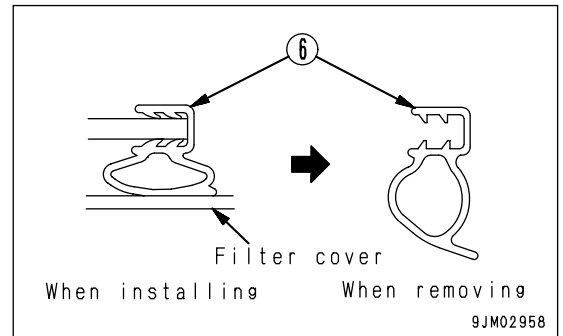

7. Remove mounting bolts (8) of filter (7), then remove cover (9).
8. Take out element (10).
9. Clean the inside of the case and the removed parts, then install a new element.  
Always use a genuine Komatsu element.
10. Install drain plug (3).
11. After installing, loosen air bleed plug (11), start the engine, and when oil oozes out, tighten plug (11).
12. Close filter cover (4), then tighten bolt (5).

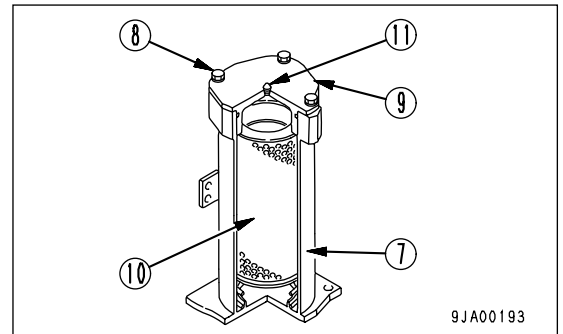

**NOTICE**

- When installing seal (6), always close filter cover (4) first.
- If the filter cover is closed after installing the seal, the seal will be damaged.

13. Install frame seal (6).

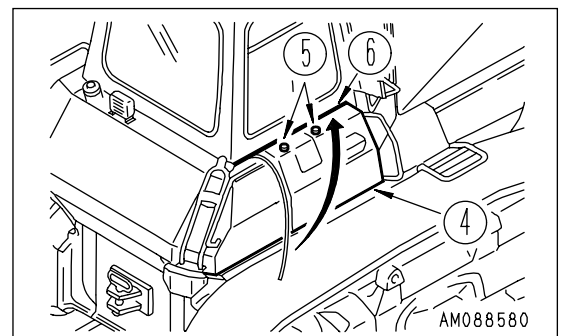

14. Add the replacement amount of engine oil through oil filler port (F).
15. After filling with oil, check that the oil is at the correct level. For details, see "CHECK OIL LEVEL IN HYDRAULIC TANK, ADD OIL (PAGE 4-45)".

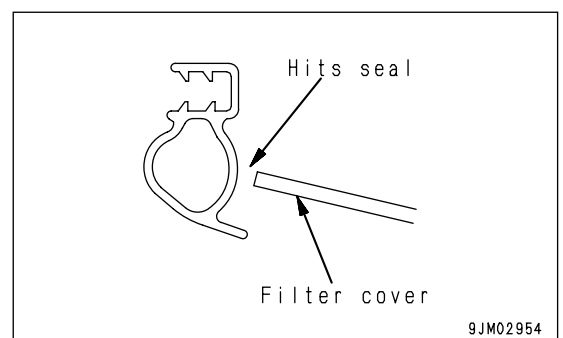

CLICK HERE TO **DOWNLOAD** THE COMPLETE MANUAL

- Thank you very much for reading the preview of the manual.
- You can download the complete manual from: [www.heydownloads.com](http://www.heydownloads.com) by clicking the link below



- Please note: If there is no response to CLICKING the link, please download this PDF first and then click on it.

CLICK HERE TO **DOWNLOAD** THE COMPLETE MANUAL