

Operation & Maintenance Manual

BULLDOZER

D155AX-6

SERIAL NUMBERS 80807 and up

ecot3

⚠ WARNING

Unsafe use of this machine may cause serious injury or death. Operators and maintenance personnel must read this manual before operating or maintaining this machine. This manual should be kept near the machine for reference and periodically reviewed by all personnel who will come into contact with it.

NOTICE

Komatsu has Operation & Maintenance Manuals written in some other languages. If a foreign language manual is necessary, contact your local distributor for availability.

KOMATSU

CLICK HERE TO **DOWNLOAD** THE COMPLETE MANUAL

- Thank you very much for reading the preview of the manual.
- You can download the complete manual from: www.heydownloads.com by clicking the link below



- Please note: If there is no response to CLICKING the link, please download this PDF first and then click on it.

CLICK HERE TO **DOWNLOAD** THE COMPLETE MANUAL

CONTENTS

FOREWORD	1- 1
BEFORE READING THIS MANUAL	1- 2
SAFETY INFORMATION	1- 3
INTRODUCTION	1- 4
USE OF MACHINE	1- 4
FRONT/REAR, LEFT/RIGHT DIRECTIONS OF MACHINE	1- 4
VISIBILITY FROM OPERATOR'S SEAT	1- 5
NECESSARY INFORMATION	1- 6
PRODUCT IDENTIFICATION NUMBER (PIN), MACHINE SERIAL NO. PLATE	1- 6
EPA REGULATIONS, ENGINE NUMBER PLATE	1- 7
BLADE SERIAL NO. PLATE POSITION	1- 8
RIPPER SERIAL NO. PLATE POSITION	1- 8
ROPS, FOPS NO. PLATE POSITION	1- 8
POSITION OF SERVICE METER	1- 8
TABLE TO ENTER SERIAL NO. AND DISTRIBUTOR	1- 9
SAFETY	2- 1
SAFETY	2- 2
SAFETY LABELS	2- 5
POSITIONS OF SAFETY PICTOGRAMS	2- 6
SAFETY LABELS	2- 7
GENERAL PRECAUTIONS COMMON TO OPERATION AND MAINTENANCE	2- 11
PRECAUTIONS BEFORE STARTING OPERATION	2- 11
PREPARATIONS FOR SAFE OPERATION	2- 11
FIRE PREVENTION	2- 13
PRECAUTIONS WHEN GETTING ON OR OFF MACHINE	2- 14
DO NOT GET CAUGHT IN WORK EQUIPMENT	2- 16
PRECAUTIONS RELATED TO PROTECTIVE STRUCTURES	2- 16
UNAUTHORIZED MODIFICATION	2- 16
PRECAUTIONS RELATED TO ATTACHMENTS AND OPTIONS	2- 16
PRECAUTIONS WHEN RUNNING ENGINE INSIDE BUILDING	2- 17
PRECAUTIONS FOR OPERATION	2- 18
PRECAUTIONS FOR JOBSITE	2- 18
STARTING ENGINE	2- 20
OPERATION	2- 23
TRANSPORTATION	2- 27
TOWING	2- 28
PRECAUTIONS FOR MAINTENANCE	2- 29
PRECAUTIONS BEFORE STARTING INSPECTION AND MAINTENANCE	2- 29
PRECAUTIONS FOR INSPECTION AND MAINTENANCE	2- 33
OPERATION	3- 1
GENERAL VIEW	3- 2
GENERAL VIEW OF MACHINE	3- 2
GENERAL VIEW OF CONTROLS AND GAUGES	3- 3
EXPLANATION OF COMPONENTS	3- 5
MACHINE MONITOR	3- 5
SWITCHES	3- 52
CONTROL LEVERS, PEDALS	3- 56
DUST INDICATOR	3- 64
FUSE BOX	3- 65

(4) Caution for high-temperature hydraulic oil (09653-03001)



(5) Caution for high-temperature coolant (09668-03001)

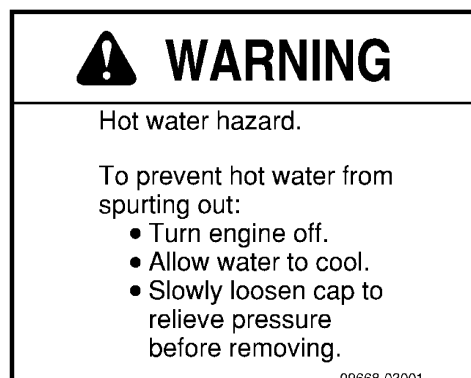

(6) Caution when adjusting track tension (09657-03003)
Safety label is attached to the back side of the inspection cover of the track frame.



(7) Caution for handling accumulator (09659-53000)



PRECAUTIONS FOR OPERATION

PRECAUTIONS FOR JOBSITE

INVESTIGATE AND CONFIRM JOBSITE CONDITIONS

On the jobsite, there are various hidden dangers that may lead to personal injury or death. Before starting operations, always check the following to confirm that there is no danger on the jobsite.

- When carrying out operations near combustible materials such as thatched roofs, dry leaves or dry grass, there is a hazard of fire, so be careful when operating.
- Check the terrain and condition of the ground at the worksite, and determine the safest method of operation. Do not operate where there is a hazard of landslides or falling rocks.
- If water lines, gas lines, or high-voltage electrical lines may be buried under the worksite, contact each utility and identify their locations. Be careful not to sever or damage any of these lines.
- Take necessary measures to prevent any unauthorized person from entering the operating area.
- In particular, if you need to operate on a road, protect pedestrian and cars by designating a person for worksite traffic duty or by installing fences around the worksite.
- When traveling or operating in water or on soft ground, check the water depth, speed of the current, bedrock, and shape of the ground beforehand and avoid any place that will obstruct travel.

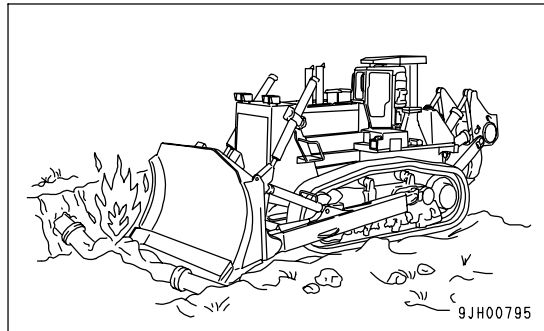

WORKING ON LOOSE GROUND

- Avoid traveling or operating your machine too close to the edge of cliffs, overhangs, and deep ditches. The ground may be weak in such areas. If the ground should collapse under the weight or vibration of the machine, there is a hazard that the machine may fall or tip over. Remember that the soil after heavy rain or blasting or after earthquakes is weak in these areas.
- When working on embankments or near excavated ditches, there is a hazard that the weight and vibration of the machine will cause the soil to collapse. Before starting operations, take steps to ensure that the ground is safe and to prevent the machine from rolling over or falling.

TOWING

PRECAUTIONS WHEN TOWING

Always use the correct towing equipment and towing method. Any mistake in the selection of the wire rope or towing bar or in the method of towing a disabled machine may lead to serious personal injury or death.

For towing, see "METHOD OF TOWING MACHINE (PAGE 3-187)".

- Always confirm that the wire rope or drawbar used for towing has ample strength for the weight of the machine being towed.
- Never use a wire rope which has cut strands (A), reduced diameter (B), or kinks (C). There is danger that the rope may break during the towing operation.
- Always wear leather gloves when handling wire rope.
- Never tow a machine on a slope.
- During the towing operation, never stand between the towing machine and the machine being towed.

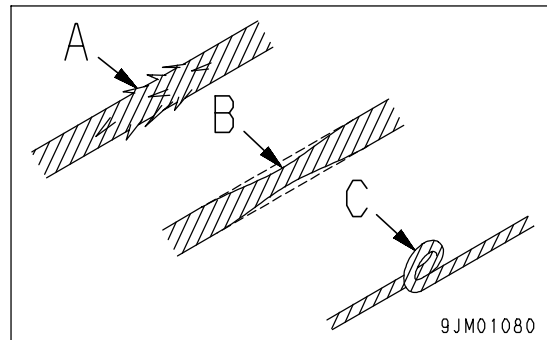

PERIODIC REPLACEMENT OF SAFETY CRITICAL PARTS

- To enable this machine to be used safely for a long period, always carry out periodic replacement of safety critical parts that have a particularly close relation to safety, such as hoses and the seatbelt.
For details of the replacement of safety critical parts, see "PERIODIC REPLACEMENT OF SAFETY CRITICAL PARTS (PAGE 4-15)".
- The material of these components naturally changes over time, and repeated use causes deterioration, wear, and fatigue. As a result, there is a hazard that these components may fail and cause serious personal injury or death. It is difficult to judge the remaining life of these components from external inspection or the feeling when operating, so always replace them at the specified interval.
- Replace or repair safety-critical parts if any defect is found, even when they have not reached the specified replacement time.

EMERGENCY MONITORS

CAUTION

If the monitor lights up red, stop the engine immediately or run at low idle, check applicable location, then perform necessary actions.

These items should be observed while the engine is running. If there is a problem, the monitor for the abnormal location lights up red and buzzer sounds, perform action immediately.

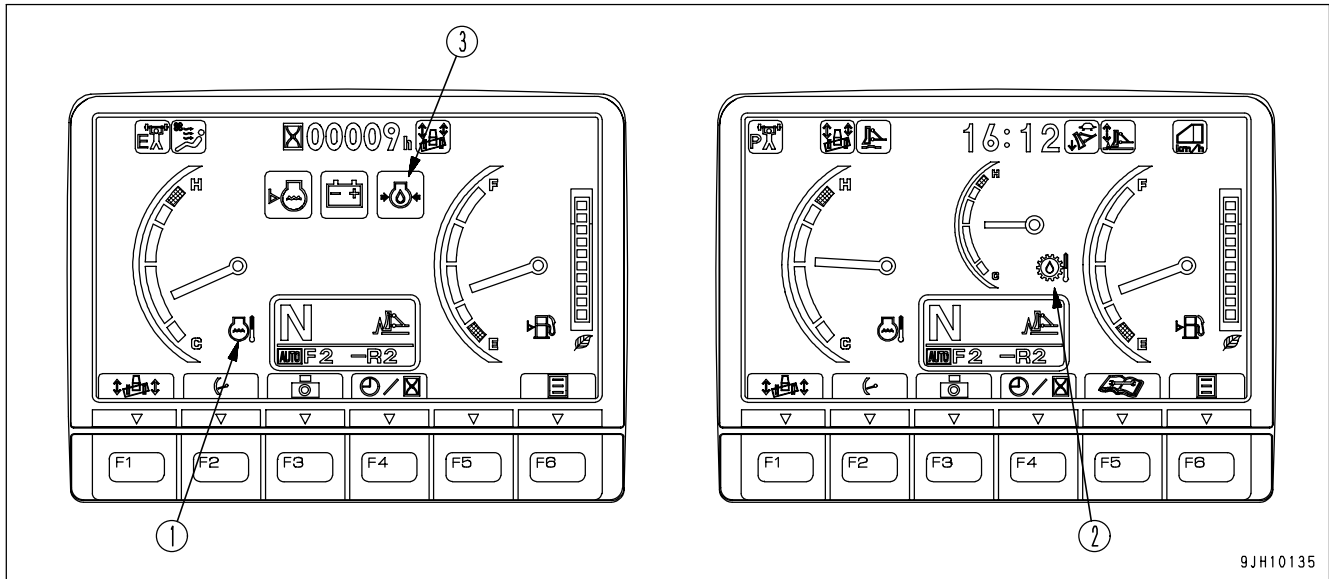

- (1) Engine coolant temperature monitor
- (2) Power train oil temperature monitor
- (3) Engine oil pressure monitor

ENGINE COOLANT TEMPERATURE MONITOR

Monitor (1) warns operator that the engine coolant temperature has risen.

If the engine coolant temperature becomes abnormally high, the monitor shows abnormal display. The overheat prevention system is automatically actuated and the engine speed drops.

Stop operations and run the engine at low idling until monitor (1) shows normal display.

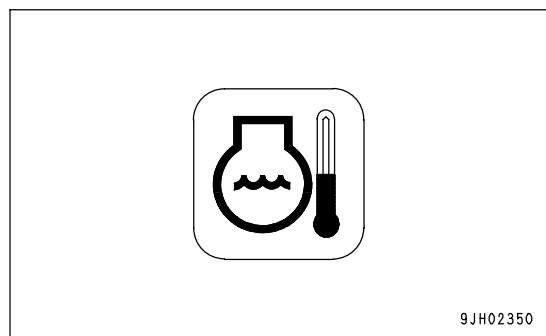

SERVICE METER, CLOCK

This meter (11) shows the total hours of operation of the machine or the present time.

When the engine is running, the service meter advances even if the machine is not moving. The service meter advances 1 for every hour that the machine is working, regardless of the engine speed.

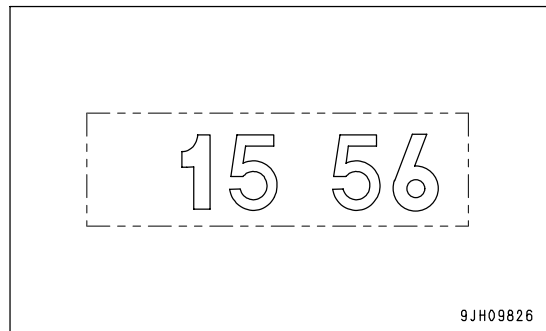
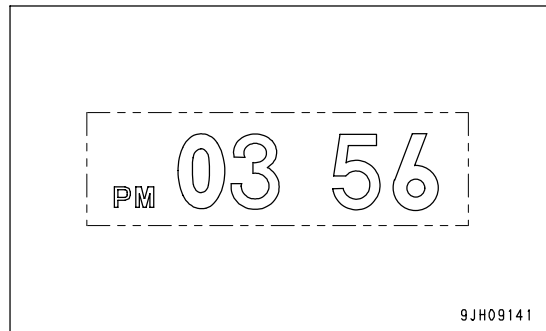
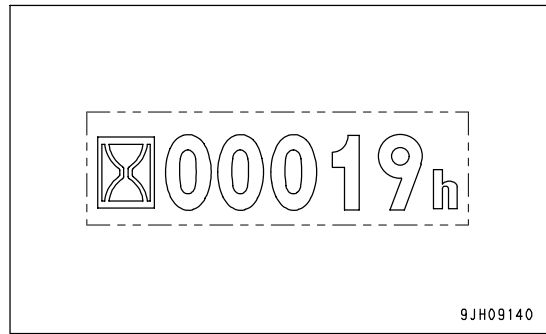

- When the standard screen is being displayed, if function switch F4 is pressed, it is possible to switch between the clock display and the service meter display.
- Clock display (12-hour or 24-hour displays are available)
To set or correct the time, press function switch F6 (user mode switch).

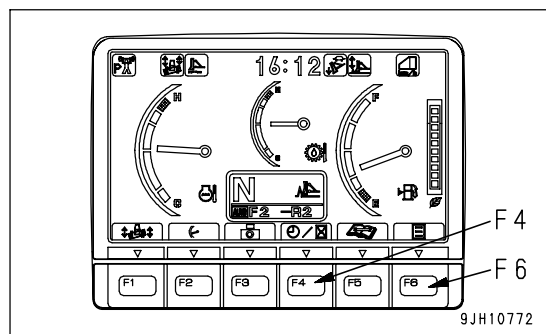

OPERATIONS ON MAINTENANCE LIST SCREEN

On the maintenance list screen, it is possible to carry out the following operations with switches F1 to F6.

- F1: Displays next page. When on the last page, it displays the first page.
- F2: Displays previous page. When on the first page, it displays the last page.
- F3: Moves to next item (1 line down). When on the last line, it moves to the first line on the next page.
- F4: Moves to previous item (1 line up). When on the first line, it moves to the last line on the previous page.
- F5: Returns to standard screen.
- F6: Resets remaining time for selected item (item highlighted in yellow) and returns to default setting screen.

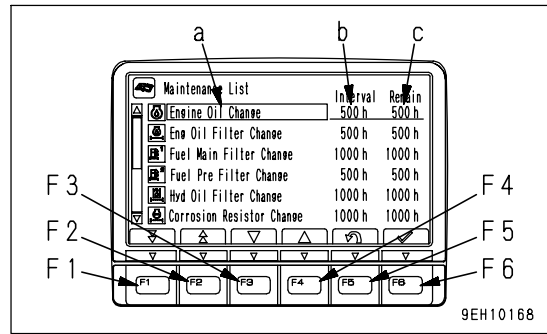

REMARK

When resetting the remaining time, keep switch F6 pressed for at least 1.5 seconds. If switch F6 is not kept pressed for at least 1.5 seconds, the switch operating sound can be heard, but the screen does not switch to the screen for resetting the remaining time.

- If no switch is operated for 30 seconds on the maintenance list screen, the screen automatically returns to the standard screen.

- On the maintenance list screen, if the time remaining until maintenance for any item is less than 30 hours, the remaining time display is highlighted in yellow. If the time remaining until maintenance becomes 0 hours, the remaining time display is highlighted in red.
- If you want to change the setting for the maintenance interval, please consult your Komatsu distributor.

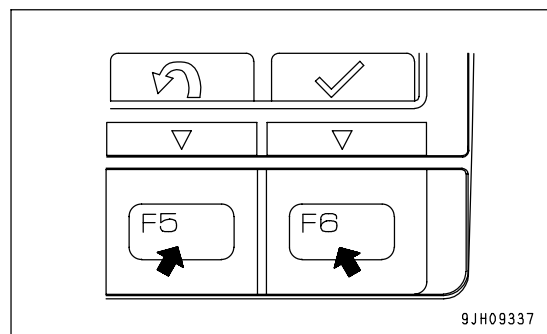
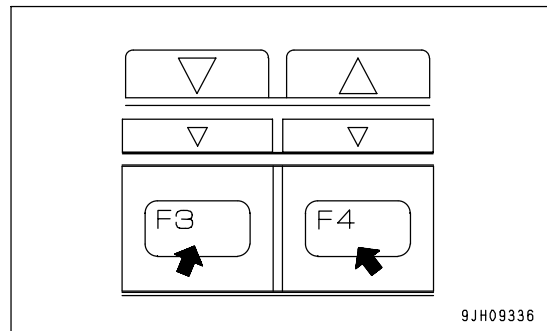
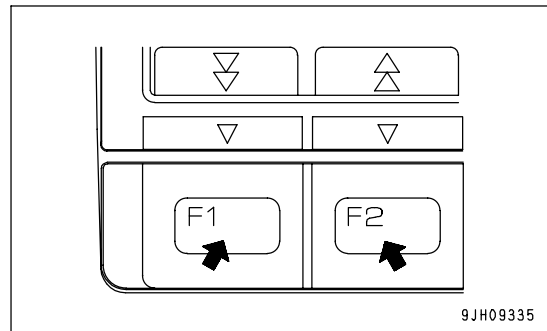

3. Select item to be adjusted (a) or (b) from the selection menu screen for screen adjustment, then press switch F6. The screen switches to the setting screen for the selected item.

(a): Standard screen adjustment

(b): Camera screen adjustment (only machines equipped with camera)

- On the mode selection screen shown on the right, it is possible to carry out the following operations with switches F3 to F6.

F3: Moves to next item (1 line down).

F4: Moves to previous item (1 line up).

F5: Returns to user menu screen.

F6: Switches to setting screen for selected item.

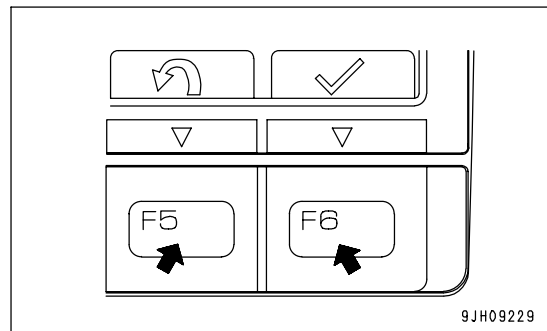
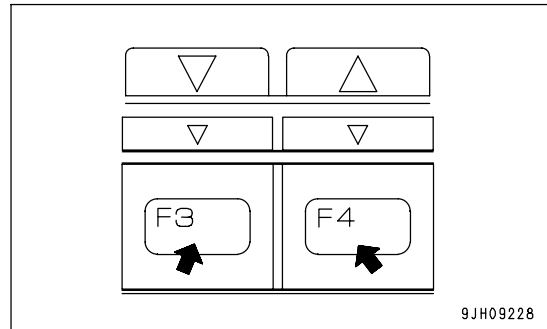
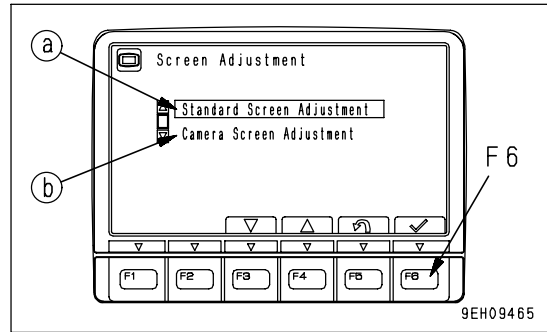

4. Use switches F2 to F6 to adjust the brightness, contrast, and back light of the selected screen.

1) Adjustment screen for standard screen

- If the light switch is at night mode ON, and the standard screen is adjusted, it is possible to adjust the brightness of the monitor screen (night mode).
- If the light switch is at day mode ON or OFF, and the standard screen is adjusted, it is possible to adjust the brightness of the monitor screen (day mode).

2) Adjusting camera screen

- The background when adjusting the camera image is the image for the No. 1 camera.
- When displaying the camera screen, the screen may become dark if the image is on snow. In such cases, we recommend adjustment of the screen.

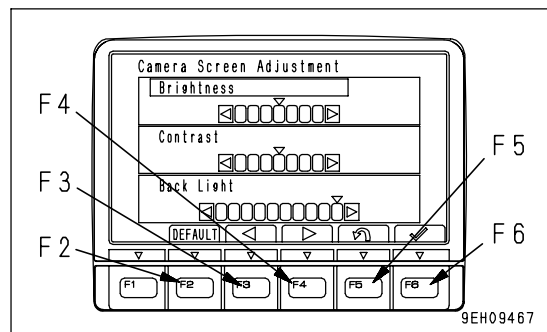
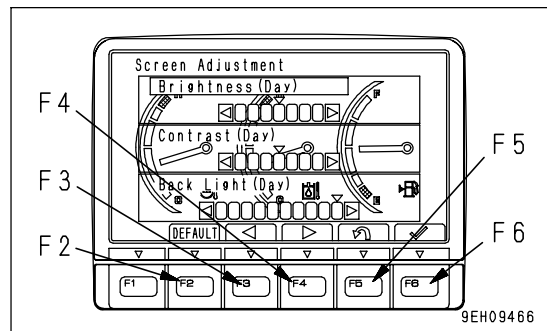

HYDRAULIC DRIVE FAN REVERSE MODE

CAUTION

- In this mode, the fan cannot be rotated in reverse with the engine running.
- Keep parking brake lever and work equipment lock lever in the LOCK position.
- The machine cannot be driven while the fan is rotating in reverse.
- To release the cooling fan from a reverse rotation, turn the fuel control dial to the MIN position, then turn the starting switch to the OFF position and stop the engine.
- When using this mode, carry out the warming-up operation thoroughly. If the warming-up operation is not carried out, the air flow may be small.

NOTICE

When using Fan Reverse for cleaning, use the following procedure.

1. Open both engine side covers.
2. Use the user menu to set the Fan Reverse mode.
3. Start the engine and blow out the dirt.
4. After stopping the engine, check that there is no dirt at any place. Be particularly careful to check that there is no dirt on the exhaust manifold or around the turbocharger.

This mode is for rotating the fan in the reverse direction from normal when cleaning the radiator core. When the starting switch is ON, use switches F3 or F4 to select the item, then press switch F6 to confirm.

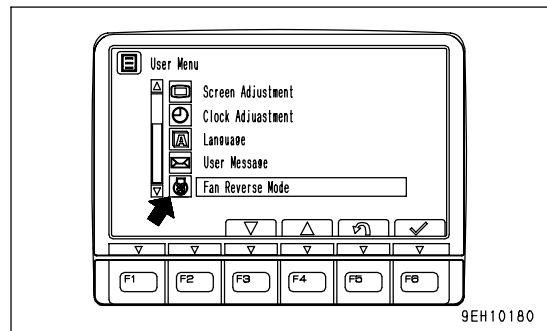

9EH10180

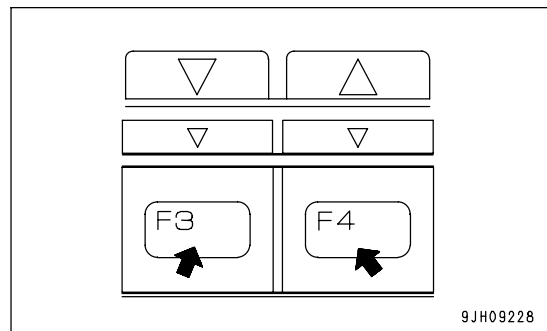

9JH09228

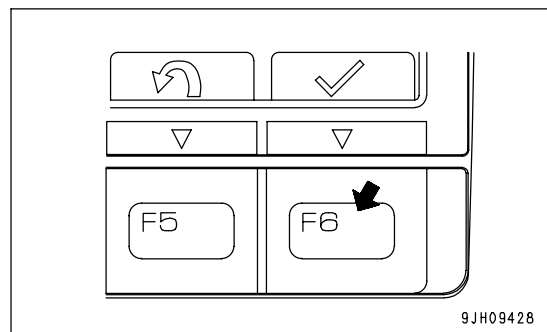

9JH09428

BLADE CONTROL LEVER

Lever (7) is used to operate the blade.

SINGLE TILTDOZER

This lever is used to carry out the blade lift and tilt operations.

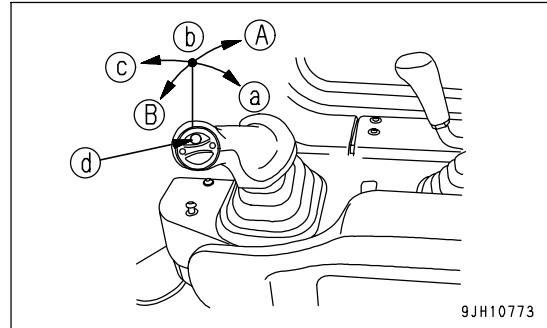

- Lifting control
- (a) RAISE
- (b) HOLD: Blade is stopped and held in position.
- (c) LOWER
- (d) FLOAT button: Blade moves freely under external force.

REMARK

- If the lever is not operated fully in the LOWER direction, it will not enter FLOAT. After operating the FLOAT mode switch on the monitor panel, keep the FLOAT button on the blade control lever pressed and operate the lever fully to the LOWER position. It will enter FLOAT.
- When using the FLOAT mode, the lever is not held in position.

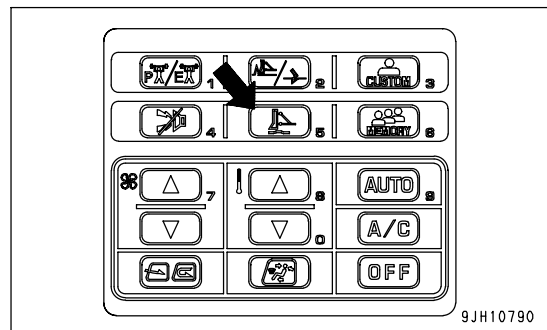
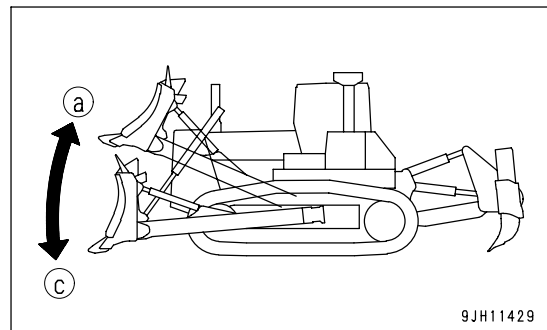

• TILT OPERATION

- (A) RIGHT TILT
- (B) LEFT TILT

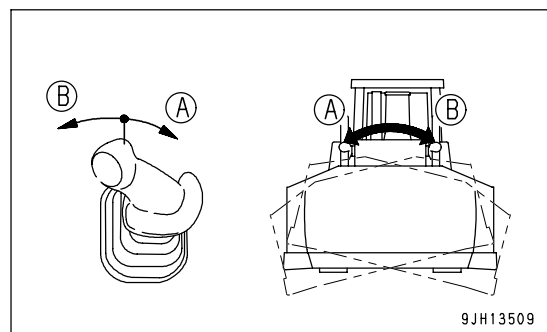

METHOD OF OPENING FUEL CAP

The method of opening or closing the fuel tank cap is as follows.

OPENING THE CAP

1. Raise lever (1) in the (a) direction.
2. When lever (1) is turned in the (c) direction (counterclockwise) by approx 35°, it stops at the stopper, and the cap can be opened.

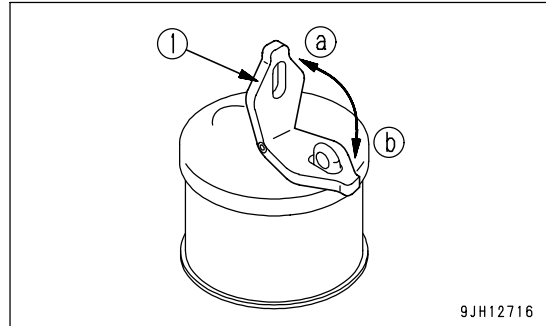
**CLOSING THE CAP**

1. After turning lever (1) in the (c) direction (counterclockwise), keep it in that position and fit the cap.
2. Turn lever (1) in the (d) direction (clockwise) until it stops at the stopper, and then tilt it in the (b) direction.

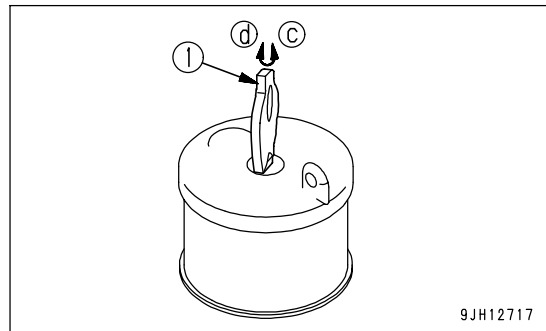

METHOD OF OPERATION

METHOD OF SETTING PRESET BUTTONS

To listen to a preset station, use band selector button (1) to select AM, FM1, or FM2, then press the preset switch number to listen to the desired station.

It is possible to preset six AM stations and 12 FM stations (FM1: 6, FM2: 6).

1. If you are playing a cassette, press the tape eject button to stop the tape.
2. Select the station to be preset.
Use band selector button (1) to select MW (AM), FM1, or FM2, then use the manual tuning button to select the frequency of the broadcasting station.
3. Press manual memory button (2) or seek tuning button (3).
4. Press preset button (4) of the number to be preset for 2 seconds while the frequency display is being shown on the display. (The preset channel and frequency are displayed and the presetting is completed).
5. Repeat Steps 2 to 4 to preset other stations.

REMARK

- Use Steps 2 to 4 also when changing the setting of a preset switch to another station.
- When the power is disconnected, such as when the battery is replaced, all the settings are deleted, so preset the stations again.

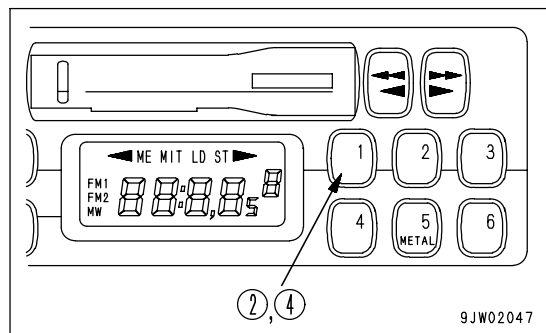
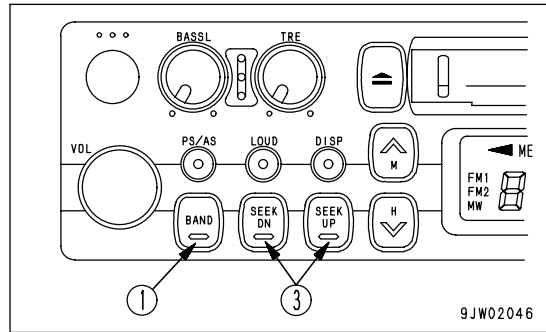

METHOD OF OPERATION

The air conditioner can be operated automatically or manually. Select the method of operation as desired.

AUTOMATIC OPERATION

1. Turn auto switch (5) ON.

- The monitors for the set temperature (a) and air flow (b) are also displayed.

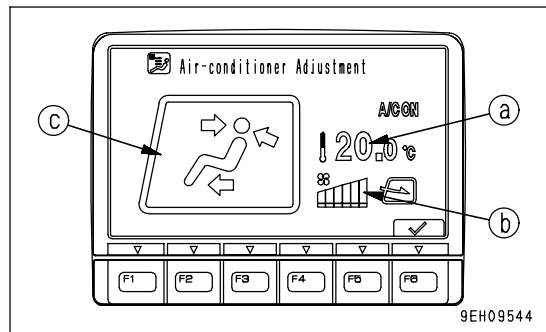
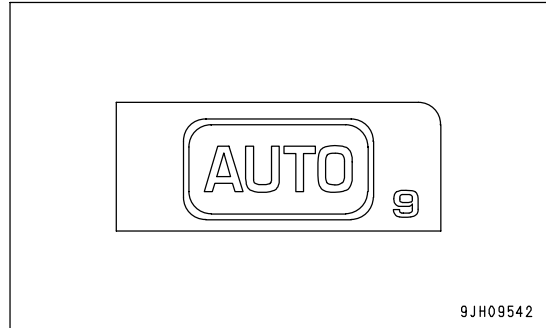

2. Use temperature set switch (3) to set to the desired temperature. The air flow, combination of vents, and selection of fresh or recirculated air is automatically selected according to the set temperature, and the air conditioner is operated automatically to provide the set temperature.

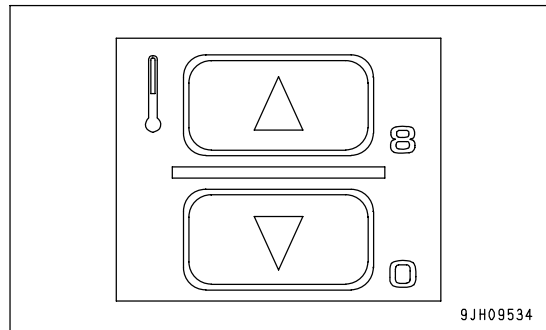

REMARK

When vent display monitor (c) displays (d) or (e), and engine coolant temperature is low, the air flow is automatically limited to prevent cold air from blowing out.

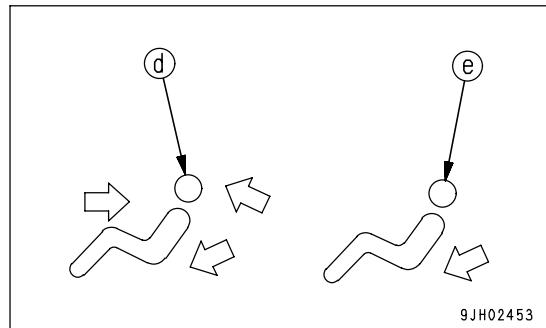

CHECK BEFORE STARTING

Always check the items in this section before starting the engine each day.

CHECK MACHINE MONITOR

1. Turn starting switch (1) to the ON position (B).
2. After the initial KOMATSU screen, check that the basic monitor screen is displayed and that the alarm buzzer sounds for approx. 2 seconds.

REMARK

If the lamps do not light up, there may be a failure or disconnection in the monitor, please contact your Komatsu distributor.

NOTICE

Do not simply use the monitor to carry out the check before starting. Always carry out the check before starting according to the procedure on the following pages.

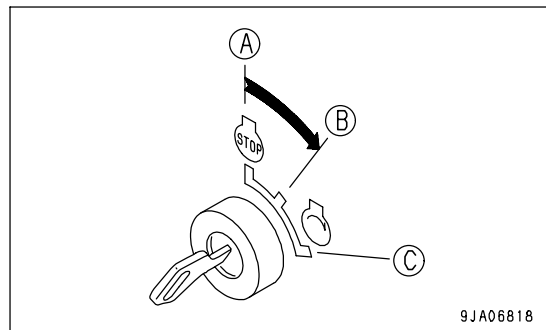
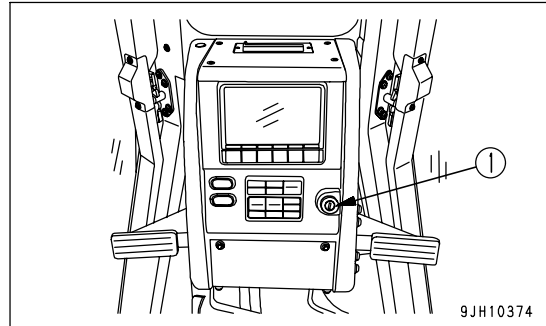

CHECK ELECTRIC WIRING

! WARNING

- If fuses are frequently blown or if there is a short circuit in the electrical wiring, locate the cause and repair or contact your Komatsu distributor.
- Accumulation of flammable material (dead leaves, twigs, grass, etc.) around the battery may cause fire, so always check and remove such material.
- Keep the top surface of the battery clean and check the breather hole in the battery cap. If it is clogged with dirt or dust, wash the battery cap to clear the breather hole.

Check for damage and wrong capacity of the fuse and any sign of disconnection or short circuit in the electric wiring. Check also for loose terminals and tighten any loose parts.

Check the wiring of the "battery", "starting motor" and "alternator" carefully in particular.

Always check if there is any accumulation of flammable material around the battery, and remove such flammable material.

Please contact your Komatsu distributor for investigation and correction of the cause.

CHECK THAT LAMPS LIGHT UP

1. Turn starting switch (1) to the ON position (B).

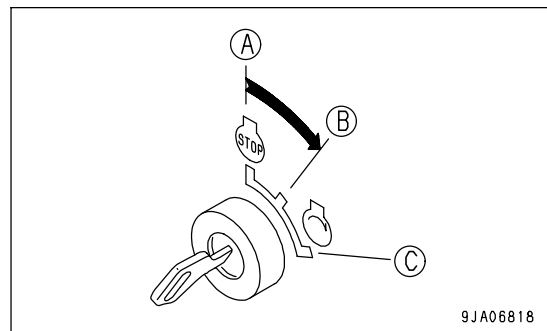

2. Turn the headlamp switch to positions (a) and (b) to check that the headlamps light up.

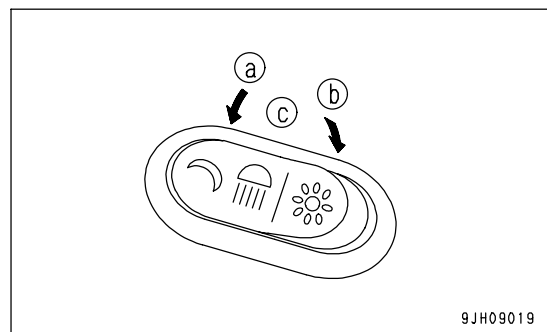

3. Turn the rear lamp switch to position (a) to check that the rear lamps light up.
If the lamps do not light, check for a broken bulb or disconnected wire, contact your Komatsu distributor for repairs.

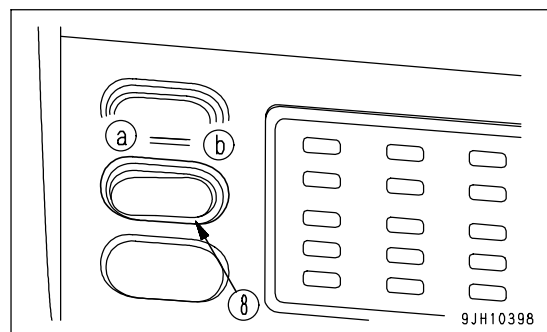

CLICK HERE TO **DOWNLOAD** THE COMPLETE MANUAL

- Thank you very much for reading the preview of the manual.
- You can download the complete manual from: www.heydownloads.com by clicking the link below



- Please note: If there is no response to CLICKING the link, please download this PDF first and then click on it.

CLICK HERE TO **DOWNLOAD** THE COMPLETE MANUAL

OPERATIONS AND CHECKS BEFORE STARTING ENGINE

! WARNING

- When starting the engine, check and make sure the work equipment lock lever (4) and parking brake lever (1) are secured in the LOCK position.
If the control levers are not locked and they are touched by accident when starting the engine, the work equipment may move unexpectedly, and this may lead to a serious injury or death.
- When standing up from the operator's seat, always set the work equipment lock lever (4) and parking brake lever (1) to the LOCK position, regardless of whether the engine is running or stopped.

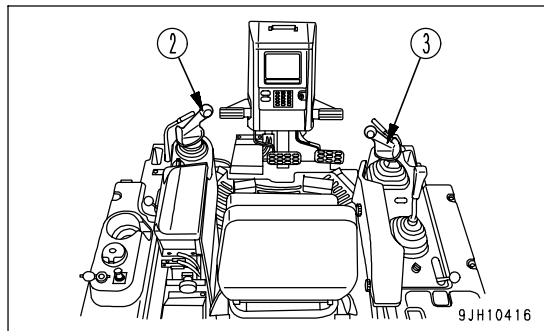
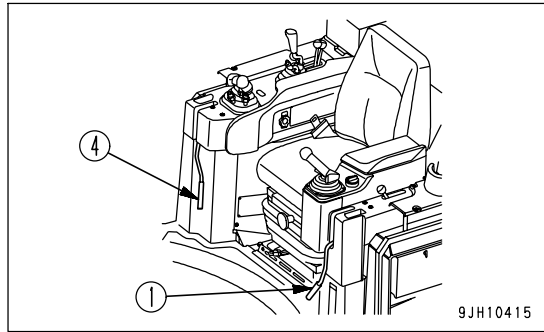

1. Check that parking brake lever (1) is locked.
If this lever is not in the LOCK position (L), the engine will not start.

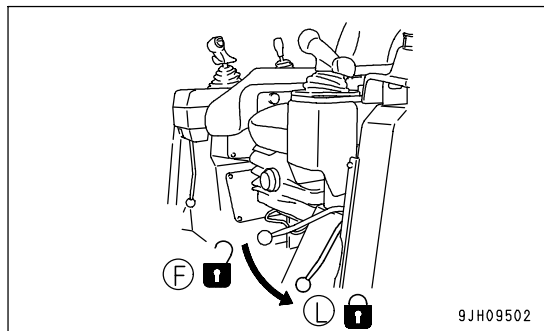

2. Check that joystick (2) is in the N (neutral) position.

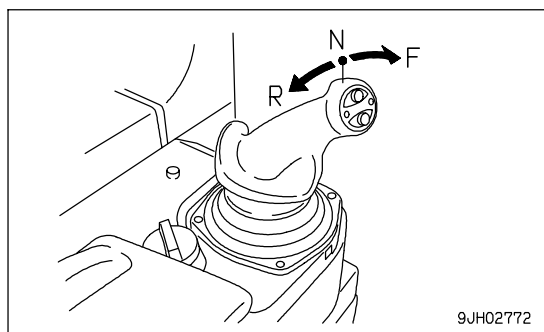

STOPPING ENGINE

NOTICE

If the engine is stopped without allowing it to cool down, there is danger that the service life of various parts of the engine will be reduced. Except in emergencies, never stop the engine suddenly.

If the engine overheats, do not stop it suddenly. Run it at low speed to allow it to cool down gradually, then stop it.

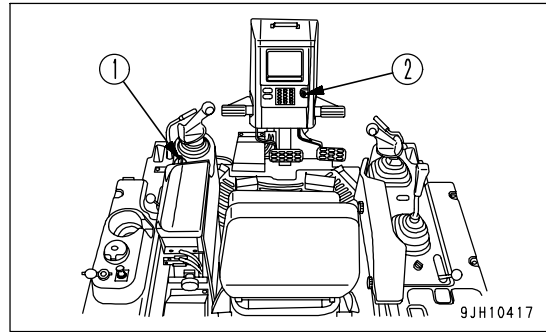

1. Turn fuel control dial (1) in the low idling (MIN) positions and run the engine at low idling speed for 5 minutes to allow the engine to gradually cool down.

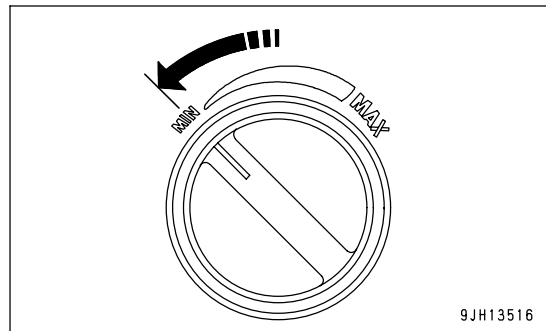

2. Turn the key in starting switch (2) to the OFF position.
The engine will stop.

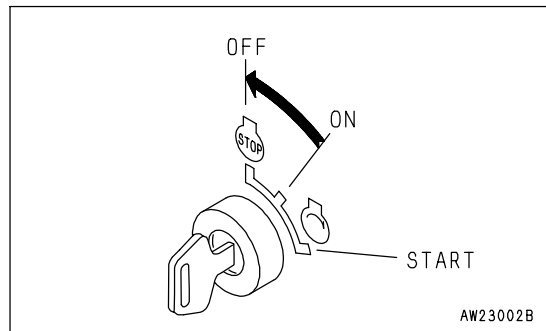

3. Remove the key from starting switch (2).

SHIFTING BETWEEN FORWARD AND REVERSE



WARNING

When switching between FORWARD and REVERSE, first check that the direction of travel is safe.



CAUTION

There is no need to stop the machine even when switching between FORWARD and REVERSE.

To increase safety, operator comfort, and the life of the transmission, leave the engine running at full speed, and always depress the decelerator pedal to lower the engine speed.

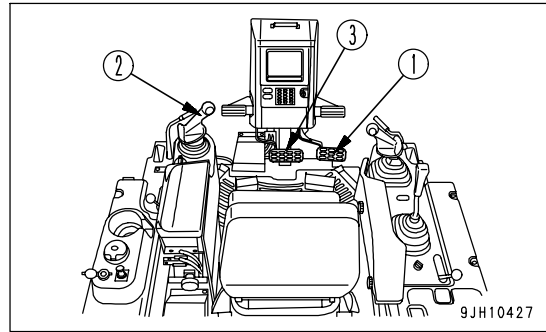

1. Depress decelerator pedal (1) to reduce the engine speed.

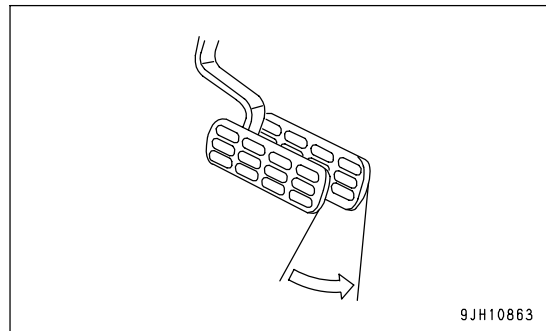

2. Move joystick (2) to the neutral position, reduce the speed, then depress brake pedal (3) and stop the machine.

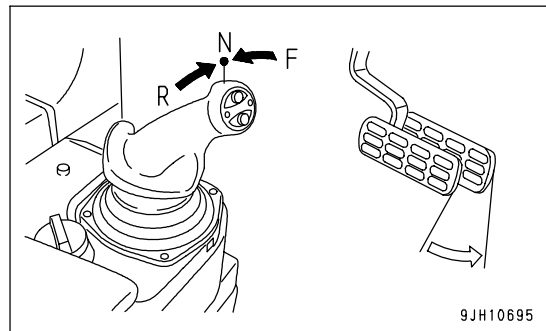

3. After depressing decelerator pedal (1), move steering, forward-reverse, gear shift lever (2) to the desired position.

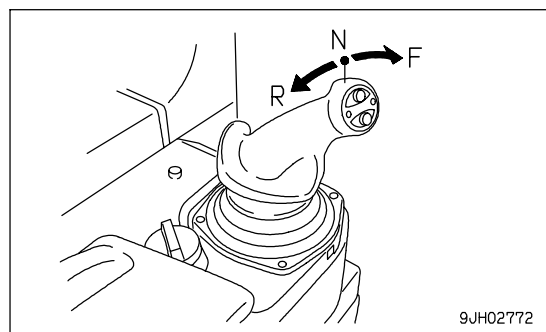

OPERATING ON SLOPES

When using the variable ripper, adjust the length of the tilt cylinder to select dimension L.

Slope face: Sloping face, such as on embankments

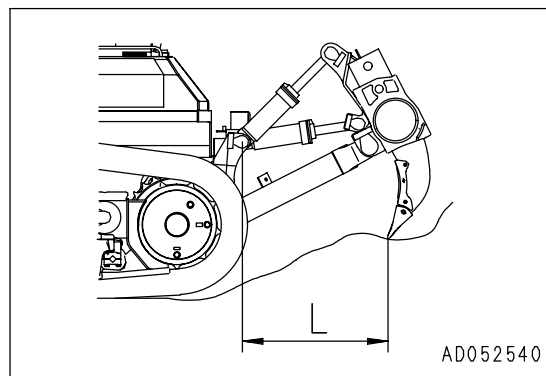
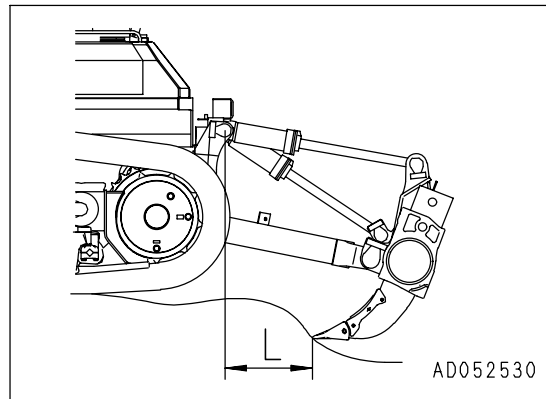

ADJUSTING POSTURE OF WORK EQUIPMENT



WARNING

When adjusting, it is dangerous if the work equipment is moved by mistake. Set the work equipment in a safe condition, then stop the engine and lock the work equipment securely with the work equipment lock lever.

BLADE ADJUSTMENT

TILTING THE TILTDOZER

NOTICE

The maximum tilt is 935 mm (3 ft 1 in).

Adjust the tilt so that it does not exceed the limit of 935 mm (3 ft 1 in).

If the maximum tilt is exceeded, excessive force will be brought to bear on all parts, and this will damage the machine.

When the blade control lever is operated, the following tilt can be obtained.

Right tilt: 460 mm (18.1 in) mm or more

Left tilt: 460 mm (18.1 in) or more

If it is necessary to have a greater tilt, do as follows.

Use bar handle (2) fixed to the right brace to turn brace (1) and change the length (ℓ) of the brace to give a maximum tilt of 1000 mm (3 ft 3 in).

- The standard distance between the joints (ℓ) is as follows.
 - Semi U-dozer: 1372 mm
 - Sigmadozer: 1292 mm

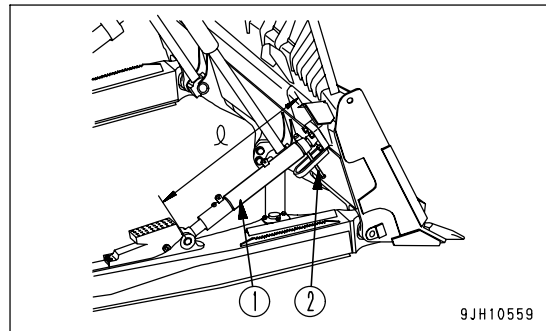

ADJUSTING SHIM IN BLADE CYLINDER CAP

Set the standard shim adjustment in the blade cylinder cap to 4 mm (0.16 in).

Remove shims to balance the wear of the cap and the ball at the end of the piston rod.

The proper clearance to be maintained with the shims is 0.2 to 0.5 mm (0.008 to 0.02 in).

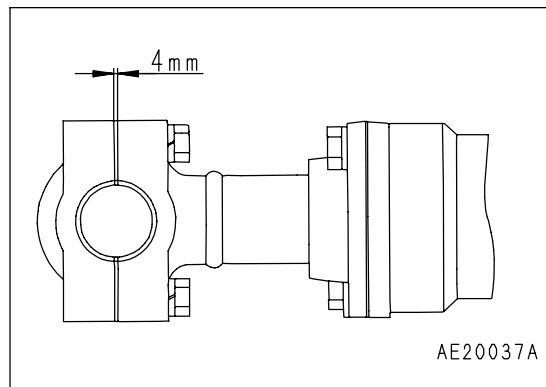

INSPECTION AND ADJUSTING

- Adjust the track shoe to the proper tension.

When adjusting the tension, measure clearance A between the idler and carrier roller in the diagram on the right. The normal clearance is 20 to 30 mm (0.8 to 1.2 in), but on bedrock, set the tension slightly higher, and on viscous ground, set it slightly looser.

(Inspect and adjust the track tension. For details of the method of inspection and maintenance for the track tension, see "WHEN REQUIRED (PAGE 4-20)".

- Check idler rollers for oil leakage as well as for loose bolts and nuts. If any trouble is detected, repair immediately.
- Check clearance B between the idler guide plate and track frame. If clearance B becomes larger, the idler will move to the side and cause the track shoe to come off. For details of the method of inspection and maintenance, see "ADJUST IDLER CLEARANCE (PAGE 4-31)".

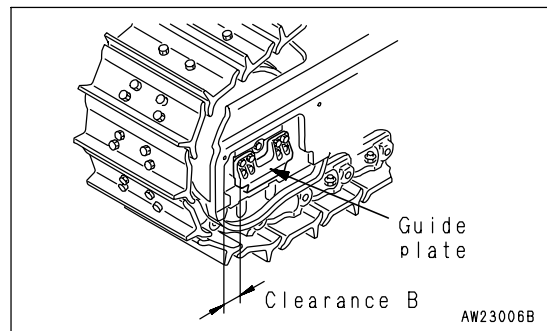
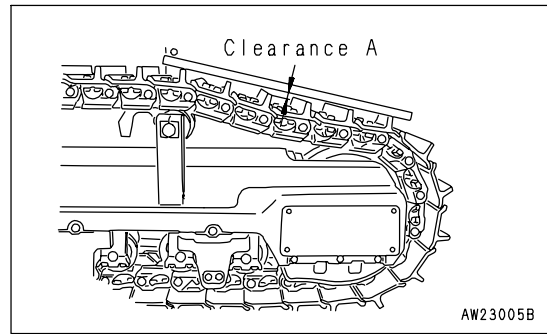

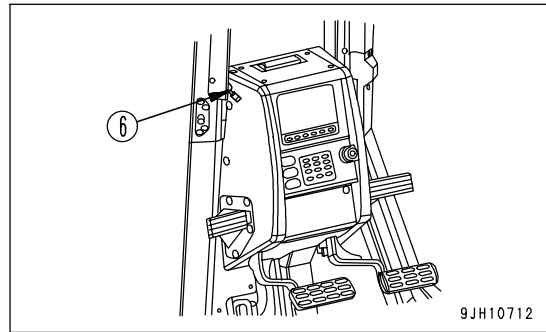

REMARK

- When installing the cab, check the colors and install the washer tank and each window washer hose correctly.
- When installing the cab, carry out the operation in accordance with the cab installation procedure manual held by your Komatsu distributor.

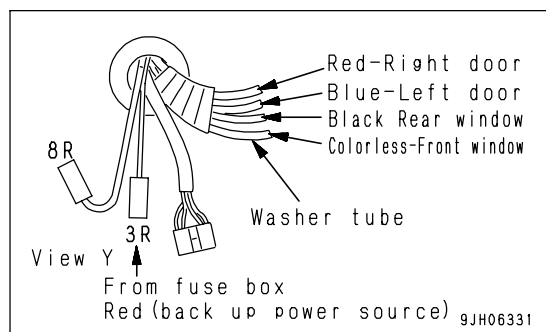
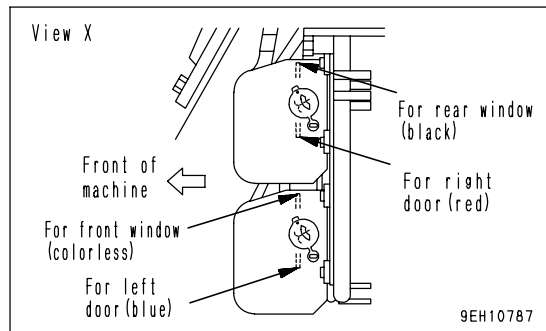
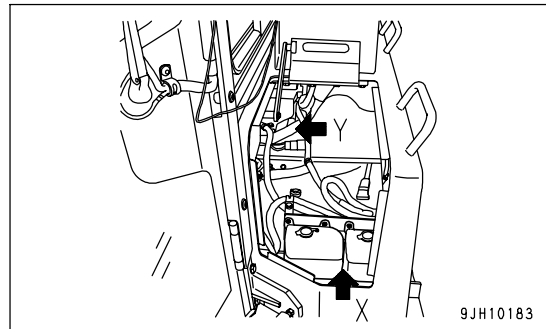

CONNECTING THE BOOSTER CABLES

Keep the starting switch of the normal machine and problem machine in the OFF position.

Connect the booster cable as follows, in the order of the numbers marked in the diagram.

1. Connect the clip of booster cable (A) to the positive (+) terminal of battery (C) on the problem machine.
2. Connect the clip at the other end of booster cable (A) to the positive (+) terminal of battery (D) on the normal machine.
3. Connect the clip of booster cable (B) to the negative (-) terminal of battery (D) on the normal machine.
4. Connect the clip at the other end of booster cable (B) to engine block (E) on the problem machine.

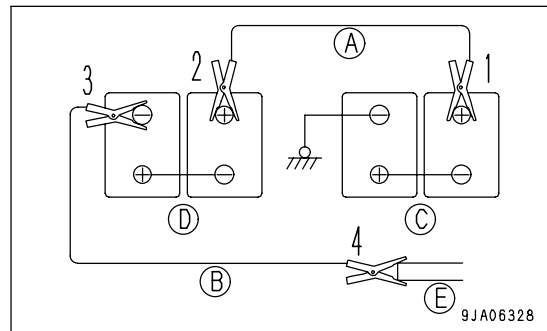

STARTING THE ENGINE



WARNING

Always check that the work equipment lock lever and Parking brake lever is set to the LOCK position, regardless of whether the machine is working normally or has failed. Check also that all the control levers are in the HOLD or NEUTRAL position.

1. Make sure the clips are firmly connected to the battery terminals.
2. Start the engine of the booster machine and keep it running at high idling speed.
3. Turn the starting switch of problem machine to the START position, and start the engine. If the engine doesn't start at first, try it again after 2 minutes.

DISCONNECTING THE BOOSTER CABLES

After the engine has started, disconnect the booster cables in the reverse of the order in which they were connected.

1. Remove the clip of booster cable (B) from engine block (E) on the problem machine.
2. Remove the clip of booster cable (B) from the negative (-) terminal of battery (D) on the normal machine.
3. Remove the clip of booster cable (A) from the positive (+) terminal of battery (D) on the normal machine.
4. Remove the clip of booster cable (A) from the positive (+) terminal of battery (C) on the problem machine.

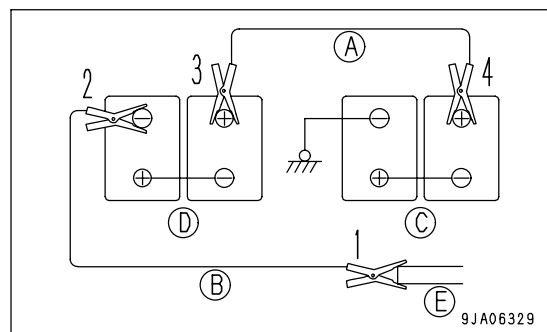

PRECAUTIONS WHEN OPENING AND CLOSING ENGINE SIDE COVER:

- When standing on track to open the engine side cover, adopt a standing position, hold the side cover with both thumbs, and open it slowly with your other fingers.
- When the side cover is open, do not open or close the cab.
Before opening or closing the cab, always close the engine side cover first.
Except, however, when the hydraulic driving fan is in the reverse rotation mode.

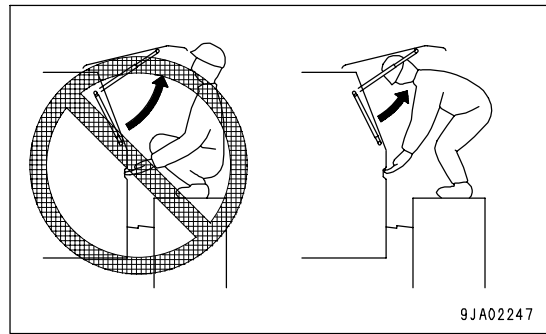

STANDARD TIGHTENING TORQUES FOR BOLTS AND NUTS

TORQUE LIST



If nuts, bolts, or other parts are not tightened to the specified torque, it will cause looseness or damage to the tightened parts, and this will cause failure of the machine or problems with operation.

Always pay careful attention when tightening parts.

Unless otherwise specified, tighten the metric nuts and bolts to the torque shown in the table below. If it is necessary to replace any nut or bolt, always use a Komatsu genuine part of the same size as the part that was replaced.

Thread diameter of bolt (a)(mm)	Width across flats (b)(mm)	Tightening torque					
		Target value			Service limit		
		Nm	kgm	lbft	Nm	kgm	lbft
6	10	13.2	1.35	9.8	11.8-14.7	1.2-1.5	8.7-10.8
8	13	31	3.2	23.1	27-34	2.8-3.5	20.3-25.3
10	17	66	6.7	48.5	59-74	6.0-7.5	43.4-54.2
12	19	113	11.5	83.2	98-123	10.0-12.5	72.3-90.4
14	22	177	18	130.2	157-196	16.0-20.0	115.7-144.7
16	24	279	28.5	206.1	245-309	25.0-31.5	180.8-227.8
18	27	382	39	282.1	343-425	35.0-43.5	253.2-314.6
20	30	549	56	405.0	490-608	50.0-62.0	361.7-448.4
22	32	745	76	549.7	662-829	67.5-84.5	488.2-611.2
24	36	927	94.5	683.5	824-1030	84.0-105.0	607.6-759.5
27	41	1320	135.0	976.5	1180-1470	120.0-150.0	868.0-1085.0
30	46	1720	175.0	1265.8	1520-1910	155.0-195.0	1121.1-1410.4
33	50	2210	225.0	1627.4	1960-2450	200.0-250.0	1446.6-1808.3
36	55	2750	280.0	2025.2	2450-3040	250.0-310.0	1808.3-2242.2
39	60	3280	335.0	2423.1	2890-3630	295.0-370.0	2133.7-2676.2

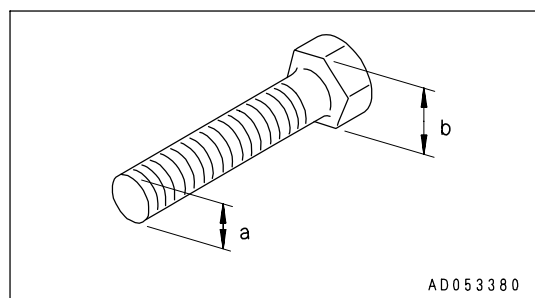

Apply the following table for Hydraulic Hose.

Thread diameter a (mm)	Width across flats b (mm)	Tightening torque					
		Target value			Permissible range		
		Nm	kgm	lbft	Nm	kgm	lbft
10	14	14.7	1.5	10.8	12.7 - 16.7	1.3 - 1.7	9.4 - 12.3
14	19	29.4	3.0	21.7	27.5 - 39.2	2.8 - 4.0	20.3 - 28.9
18	24	78.5	8.0	57.9	58.8 - 98.1	6.0 - 10.0	43.4 - 72.3
22	27	117.7	12.0	86.6	88.3 - 137.3	9.0 - 14.0	65.1 - 101.3
24	32	147.1	15.0	108.5	117.7 - 176.5	12.0 - 18.0	86.8 - 130.2
30	36	215.7	22.0	159.1	176.5 - 245.2	18.0 - 25.0	130.2 - 180.8
33	41	255.0	26.0	188.1	215.7 - 284.4	22.0 - 29.0	159.1 - 209.8

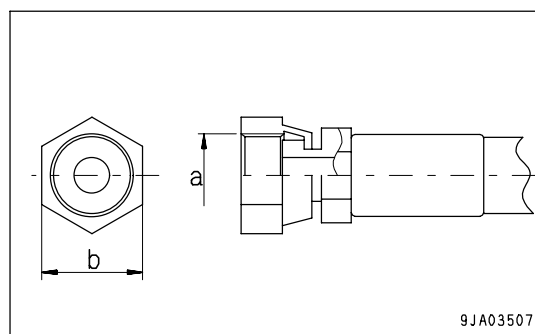

NOTICE

If small holes or thinner parts are found on the element when it is checked with an electric bulb after cleaning and drying, replace the element. When cleaning the element, do not hit it or beat it against something. Do not use an element whose folds or gasket or seal are damaged.

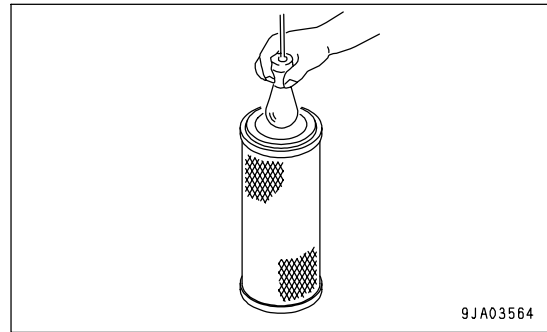

6. Remove the cloth or tape cover installed in Step 3.
7. Check that there is no dirt or oil stuck to the seal portion of the new element or cleaned element. Wipe off any dirt or oil.

NOTICE

- The inner element must not be cleaned and used again. When replacing the outer element, replace the inner element at the same time.
- If the inner element is not installed properly and the outer element and cover are installed, there is danger that the outer element will be damaged.
- The seal portion on imitation parts lacks precision, and allows the entry of dust, which leads to damage of the engine. Do not use such imitation parts.

8. Push the outer element in straight with your hand when installing it to the air cleaner body. If the outer element is held and rocked lightly up and down and to the left and right while pushing it in, the outer element can be inserted easily.

1) Check that the inner element is not loose. If it is loose, insert it securely.

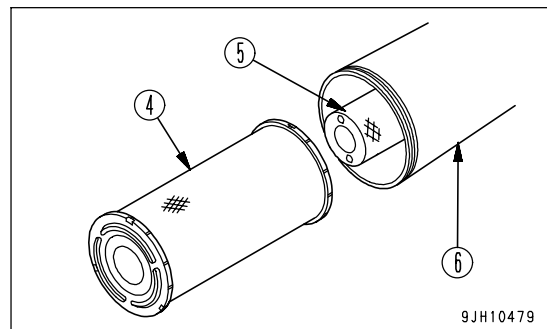

2) If the yellow piston in dust indicator (1) overlaps the red zone (A) on the outer diameter immediately after the outer element is cleaned, replace both the inner and outer elements.

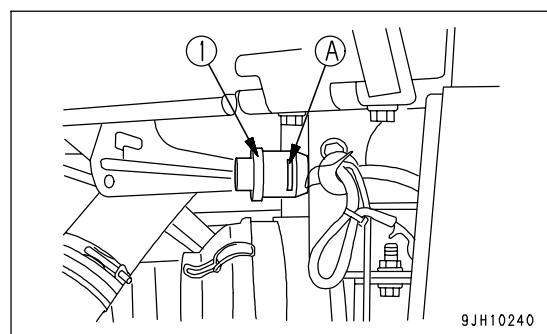

- 2) When installing end bit (4), put top face (5) of the end bit in tight contact with stopper (6), then tighten the bolt.
6. After several hours of running, retourque the nuts.

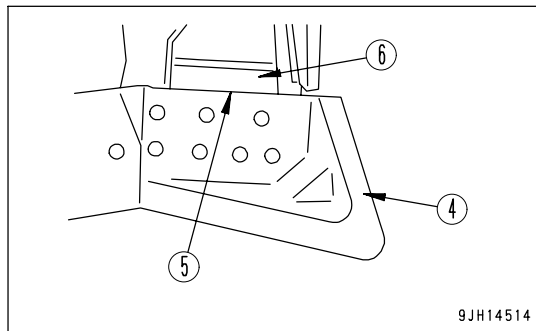

LUBRICATE DOOR HINGE

If the door makes a squeaking noise when it is opened or closed, spray lubricant in through the split in the hinge bushing. If the bushing is worn, replace the hinge.

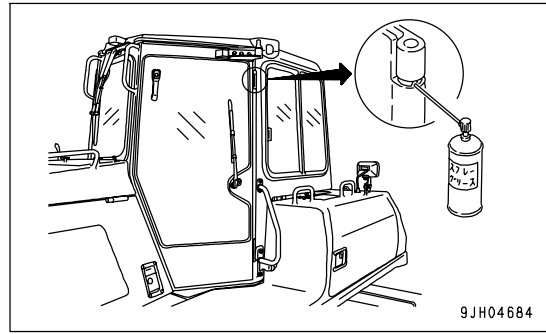

CHECK DOOR LATCH

WARNING

It is quite dangerous if the machine suddenly starts to move during the inspection work. Stop the engine and operate the parking brake lever to the LOCK (L) position without fail.

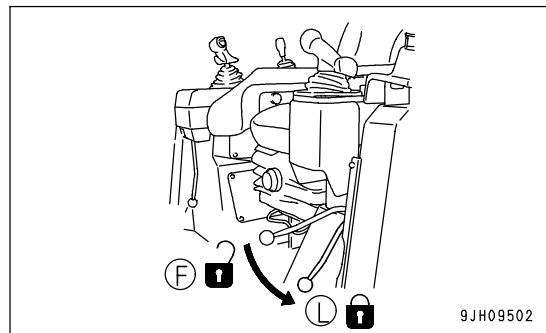

Check

Hold the door open-locked, and check that there is still grease inside the latch. If the amount of grease is low or there is no more grease, coat the inside of the latch with grease from portion (1).

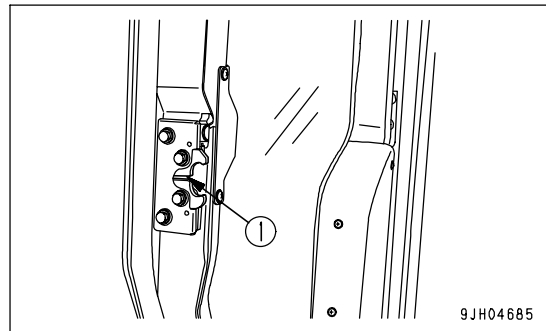

REMARK

If there is no more grease inside the latch, the movement will become poor because of dust inside the latch, and the handle may be stiff when opening the door.

CHECK DOOR LOCK STRIKER

If wear (A) of the door of lock striker exceeds 0.5 mm (0.02 in), replace the striker. If it is used as it is, the play will increase and this may result in breakage of the hinge or door lock.

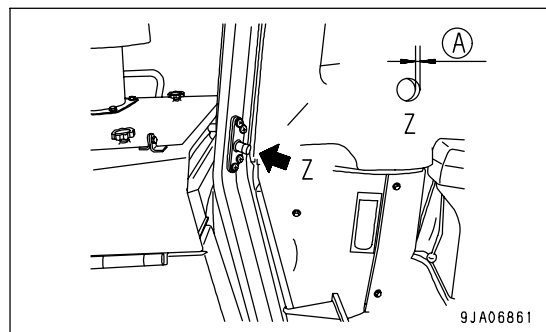

CHECK OIL LEVEL IN FINAL DRIVE CASE, ADD OIL**WARNING**

The oil is at high temperature immediately after the machine has been operated. Wait for the oil to cool down before starting the operation.

1. Stop the machine so that drain plug (1) is at the bottom.
2. Remove oil level plug (2) and check whether the final drive case is filled with oil to lower edge of the plug hole.
3. If the oil level is low, remove plug (3) and add engine oil until it overflows from oil level plug (2).

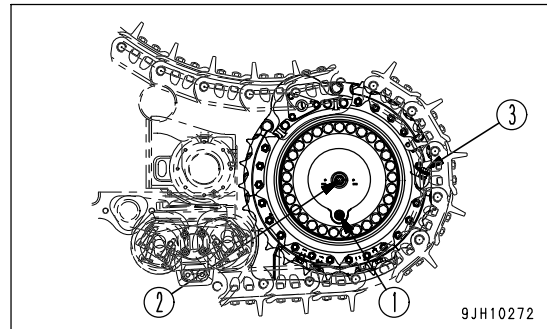
**CHECK OIL LEVEL IN DAMPER CASE, ADD OIL**

1. Open the engine side cover on the left side of the machine.
2. Remove dipstick (G), and wipe the oil off with a cloth.
3. Fully insert dipstick (G) into filler pipe, then remove it.
4. The oil should be between the H and L marks on dipstick (G).
If the oil is below the L mark, add oil through the dipstick insertion port.

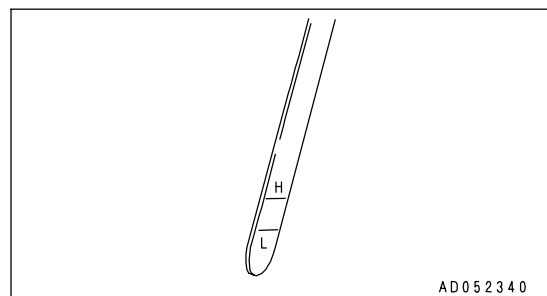
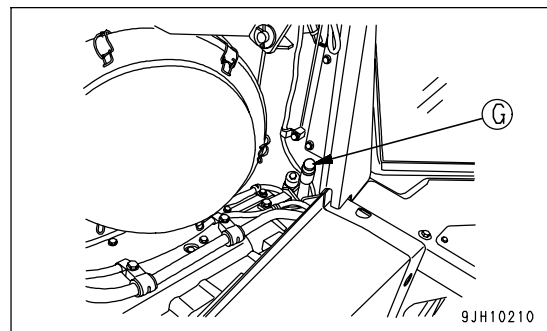

5. If the oil is above the H mark, remove the undercover under the machine, drain the excess oil from drain plug (P), then check the oil level again.

REMARK

- Check the oil level while the engine is stopped.
- If the machine is inclined, set it in a level position before checking the oil level.

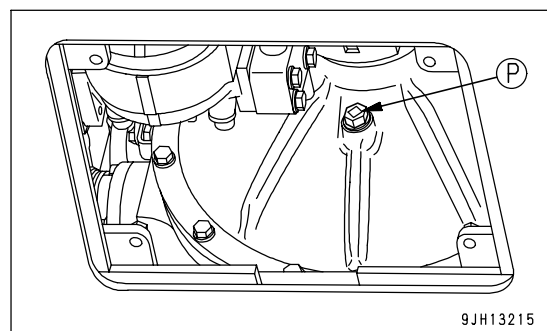

CHANGE OIL IN ENGINE OIL PAN, REPLACE ENGINE OIL FILTER CARTRIDGE

**WARNING**

The oil is at high temperature after the engine has been operated, so never change the oil immediately after finishing operations. Wait for the oil to cool down before changing it.

- Oil replacement amount: 37 liters (9.78 US gal)
- Prepare a socket wrench and filter wrench.

After the machine has been operated for 6 months, even if it has not been operated for 500 hours, change the engine oil and replace the filter cartridge at 6 months.

And after the machine has been operated for 500 hours, even if it has not been operated for 6 months, change the engine oil and replace the filter cartridge at 500 hours.

1. Remove the cover (1) on the bottom of the machine and set a container to catch the drained oil directly under the drain plug.

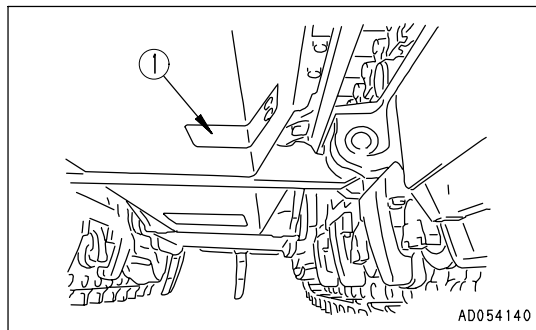

2. Remove cover (A).

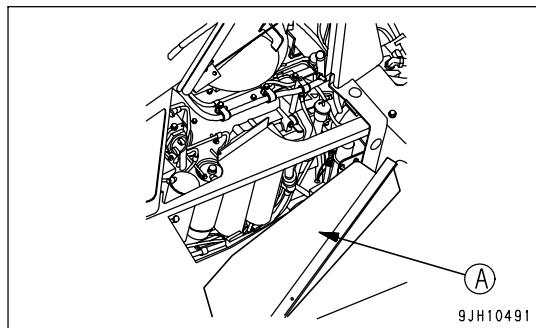

CHECK, CLEAN FUEL STRAINER

1. Tighten fuel supply valve (1) at the bottom of the fuel tank, remove cap (2), then wash the strainer and strainer case. The strainer forms one unit with the cap.
2. After checking and cleaning the strainer, set it in the case, then tighten the cap.
3. After installing, open fuel supply valve (1).

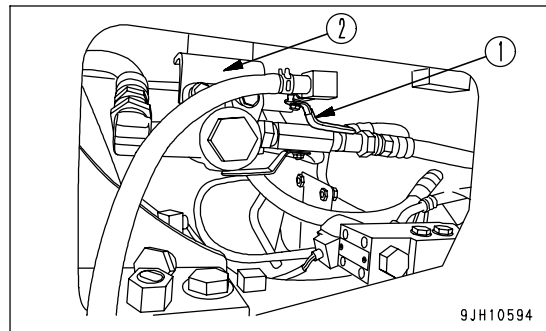
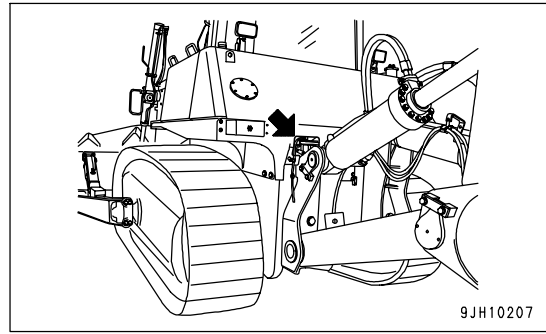

CHECKING CHARGE PRESSURE OF NITROGEN GAS IN ACCUMULATOR (FOR CONTROL CIRCUIT) **WARNING**

The accumulator is charged with high-pressure nitrogen gas, so mistaken operation may cause an explosion, which will lead to serious injury or damage. When handling the accumulator, always do as follows.

- The pressure in the hydraulic circuit cannot be completely removed. When removing the hydraulic equipment, do not stand in the direction that the oil spurts out when carrying out the operation. In addition, loosen the bolts slowly when carrying out the operation.
- Do not disassemble the accumulator.
- Do not bring it near flame or dispose of it in fire.
- Do not make holes in it or weld it.
- Do not hit it, roll it, or subject it to any impact.
- When disposing of the accumulator, the gas must be released. Please contact your Komatsu distributor to have this work carried out.

NOTICE

If the nitrogen gas charge pressure in the accumulator is low and operations are continued, it will become impossible to release the remaining pressure inside the hydraulic circuit if a failure occurs on the machine.

FUNCTION OF ACCUMULATOR

The accumulator stores the pressure in the control circuit. Even after the engine is stopped, the control circuit can be operated, so the following actions are possible.

- If the control lever is operated in the direction to lower the work equipment, it is possible for the work equipment to go down under its own weight.
- The pressure in the hydraulic circuit can be released.

The accumulator is installed to the position shown in the diagram on the right.

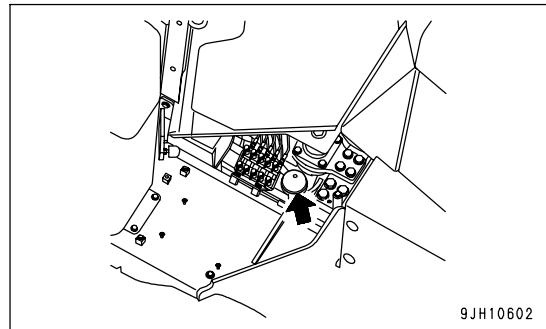

9JH10602

SPECIFICATIONS

Item		Unit	D155AX-6	
Operating weight (without operator) *1		kg (lb)	39,500 (87,100)	
Blade unit weight (including cylinder)		kg (lb)	5,360 (11,820)	
Ripper unit weight		kg (lb)	2,440 (5,380)	
Name of engine		-	Komatsu SAA6D140E-5 diesel engine	
Engine horsepower		kW (HP) /rpm	239 (320)/1,900	
A	Overall length	mm (ft in)	8,225 (27')	
B	Overall height	mm (ft in)	3,395 (11' 2")	
C	Overall width	mm (ft in)	4,060 (13' 4")	
Travel speed (1st/2nd/3rdLO/3rd)		Forward	km/h (MPH)	3.8/5.6/7.5/11.6 (2.4/3.5/4.7/7.2)
		Reverse	km/h (MPH)	4.6/6.8/9.2/14.0 (2.9/4.2/5.7/8.7)

*1: Hydraulic type tiltdozer (Strengthened SIGMADOZER)
 With hydraulic variable giant ripper, ROPS cab, 560 mm (22.1 in) HD shoe, side cover, air conditioner

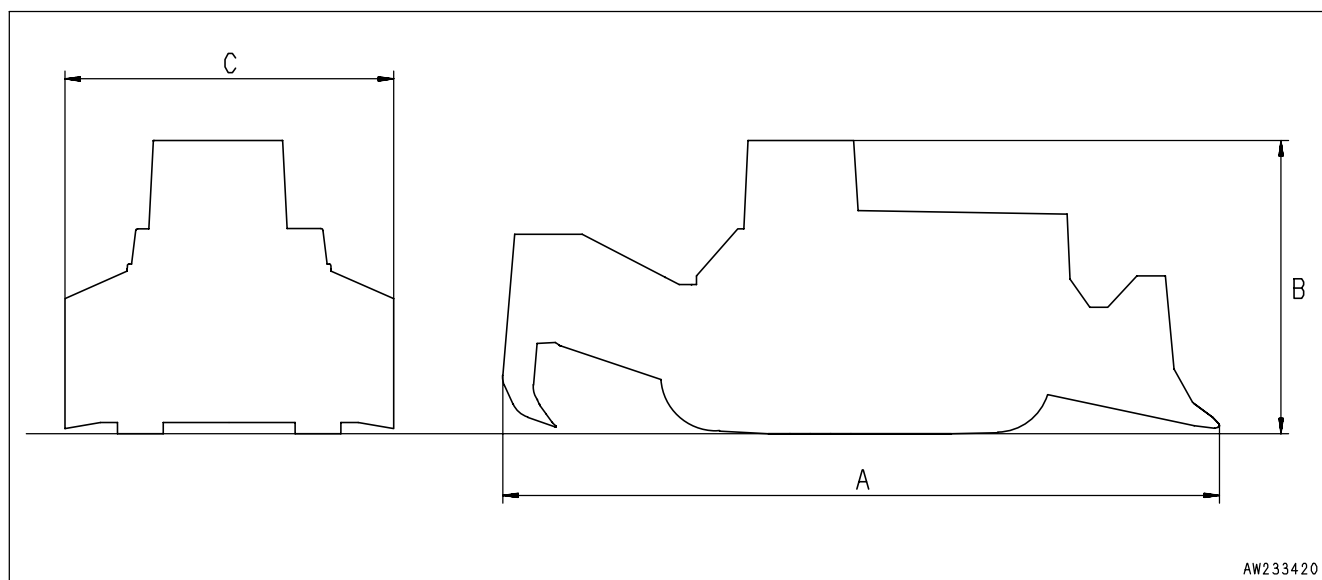

CLICK HERE TO **DOWNLOAD** THE COMPLETE MANUAL

- Thank you very much for reading the preview of the manual.
- You can download the complete manual from: www.heydownloads.com by clicking the link below



- Please note: If there is no response to CLICKING the link, please download this PDF first and then click on it.

CLICK HERE TO **DOWNLOAD** THE COMPLETE MANUAL