

CEAM010200

Operation & Maintenance Manual

930E-3

DUMP TRUCK

SERIAL NUMBERS **A30304 - A30309**

KOMATSU[®]

CLICK HERE TO **DOWNLOAD** THE COMPLETE MANUAL

- Thank you very much for reading the preview of the manual.
- You can download the complete manual from: www.heydownloads.com by clicking the link below



- Please note: If there is no response to CLICKING the link, please download this PDF first and then click on it.

CLICK HERE TO **DOWNLOAD** THE COMPLETE MANUAL

TABLE OF CONTENTS

| SUBJECT | SECTION / PAGE |
|--|-----------------------|
| OPERATING INSTRUCTIONS | 30-1 |
| PREPARING FOR OPERATION | 30-1 |
| Safety Is Thinking Ahead | 30-1 |
| At The Truck - Ground Level Walk Around Inspection | 30-1 |
| ENGINE START-UP SAFETY PRACTICES | 30-4 |
| Cold Weather Starting | 30-5 |
| AFTER ENGINE HAS STARTED | 30-5 |
| MACHINE OPERATION SAFETY PRECAUTIONS | 30-6 |
| MACHINE OPERATION ON THE HAUL ROAD | 30-6 |
| STARTING ON A GRADE WITH A LOADED TRUCK | 30-7 |
| PASSING | 30-7 |
| LOADING | 30-7 |
| DUMPING | 30-8 |
| Raising The Dump Body | 30-8 |
| Lowering The Dump Body | 30-8 |
| TOWING | 30-10 |
| SAFE PARKING PROCEDURES | 30-10 |
| NORMAL ENGINE SHUTDOWN PROCEDURE | 30-10 |
| DELAYED ENGINE SHUTDOWN PROCEDURE | 30-11 |
| SUDDEN LOSS OF ENGINE POWER | 30-12 |
| RESERVE ENGINE OIL SYSTEM (Optional) | 30-13 |
| OPERATOR CAB AND CONTROLS | 32-1 |
| STEERING WHEEL AND CONTROLS | 32-2 |
| Horn Button | 32-2 |
| Telescope Lock Ring | 32-2 |
| Tilt Wheel Lever | 32-2 |
| Turn Signal/Headlight Dimmer | 32-2 |
| DYNAMIC RETARDING | 32-2 |
| Retarder Control Lever | 32-3 |
| Dynamic Retarder/Service Brake Pedal | 32-3 |
| Accelerator (Throttle) Pedal | 32-3 |
| Starting on a Grade With a Loaded Truck | 32-3 |
| GRADE/SPEED RETARD CHART | 32-4 |
| INSTRUMENT PANEL | 32-5 |
| OVERHEAD PANEL AND DISPLAYS | 32-5 |
| CENTER CONSOLE | 32-6 |
| F-N-R Selector Switch | 32-6 |
| Hoist Control Lever | 32-7 |

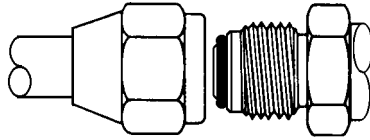

TABLE IV.
TORQUE CHART FOR JIC 37° SWIVEL NUTS
WITH OR WITHOUT O-RING SEALS

| SIZE CODE | TUBE SIZE (O.D.) | THREADS UNF-2B | TORQUE FT. LBS. |
|-----------|------------------|----------------|-----------------|
| - 2 | 0.125 | 0.312 - 24 | 4 ±1 |
| - 3 | 0.188 | 0.375 - 24 | 8 ±3 |
| - 4 | 0.250 | 0.438 - 20 | 12 ±3 |
| - 5 | 0.312 | 0.500 - 20 | 15 ±3 |
| - 6 | 0.375 | 0.562 - 18 | 18 ±5 |
| - 8 | 0.500 | 0.750 - 16 | 30 ±5 |
| - 10 | 0.625 | 0.875 - 14 | 40 ±5 |
| - 12 | 0.750 | 1.062 - 12 | 55 ±5 |
| - 14 | 0.875 | 1.188 - 12 | 65 ±5 |
| - 16 | 1.000 | 1.312 - 12 | 80 ±5 |
| - 20 | 1.250 | 1.625 - 12 | 100 ±10 |
| - 24 | 1.500 | 1.875 - 12 | 120 ±10 |
| - 32 | 2.000 | 2.500 - 12 | 230 ±20 |

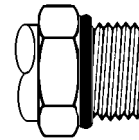

TABLE VI.
TORQUE CHART FOR
O-RING BOSS FITTINGS

| SIZE CODE | TUBE SIZE (O.D.) | THREADS UNF-2B | TORQUE FT. LBS. |
|-----------|------------------|----------------|-----------------|
| - 2 | 0.125 | 0.312 - 24 | 4 ±2 |
| - 3 | 0.188 | 0.375 - 24 | 5 ±2 |
| - 4 | 0.250 | 0.438 - 20 | 8 ±3 |
| - 5 | 0.312 | 0.500 - 20 | 10 ±3 |
| - 6 | 0.375 | 0.562 - 18 | 13 ±3 |
| - 8 | 0.500 | 0.750 - 16 | 24 ±5 |
| - 10 | 0.625 | 0.875 - 14 | 32 ±5 |
| - 12 | 0.750 | 1.062 - 12 | 48 ±5 |
| - 14 | 0.875 | 1.188 - 12 | 54 ±5 |
| - 16 | 1.000 | 1.312 - 12 | 72 ±5 |
| - 20 | 1.250 | 1.625 - 12 | 80 ±5 |
| - 24 | 1.500 | 1.875 - 12 | 80 ±5 |
| - 32 | 2.000 | 2.500 - 12 | 96 ±10 |

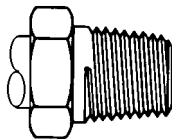

TABLE V.
TORQUE CHART FOR
PIPE THREAD FITTINGS

| SIZE CODE | PIPE THREAD SIZE | WITH SEALANT FT. LBS. | WITHOUT SEALANT FT. LBS. |
|-----------|------------------|-----------------------|--------------------------|
| - 2 | 0.125 - 27 | 15 ±3 | 20 ±5 |
| - 4 | 0.250 - 18 | 20 ±5 | 25 ±5 |
| - 6 | 0.375 - 18 | 25 ±5 | 35 ±5 |
| - 8 | 0.500 - 14 | 35 ±5 | 45 ±5 |
| - 12 | 0.750 - 14 | 45 ±5 | 55 ±5 |
| - 16 | 1.000 - 11.50 | 55 ±5 | 65 ±5 |
| - 20 | 1.250 - 11.50 | 70 ±5 | 80 ±5 |
| - 24 | 1.500 - 11.50 | 80 ±5 | 95 ±10 |
| - 32 | 2.000 - 11.50 | 95 ±10 | 120 ±10 |

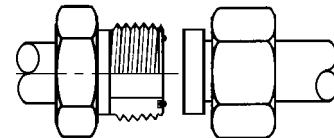

TABLE VII.
TORQUE CHART FOR
O-RING FACE SEAL FITTINGS

| SIZE CODE | TUBE SIZE (O.D.) | THREADS UNF-2B | TORQUE FT. LBS. |
|-----------|------------------|----------------|-----------------|
| - 4 | 0.250 | 0.438 - 20 | 11 ±1 |
| - 6 | 0.375 | 0.562 - 18 | 18 ±2 |
| - 8 | 0.500 | 0.750 - 16 | 35 ±4 |
| - 10 | 0.625 | 0.875 - 14 | 51 ±5 |
| - 12 | 0.750 | 1.062 - 12 | 71 ±7 |
| - 16 | 1.000 | 1.312 - 12 | 98 ±6 |
| - 20 | 1.250 | 1.625 - 12 | 132 ±7 |
| - 24 | 1.500 | 1.875 - 12 | 165 ±15 |

- Check for flat tires periodically during a shift. If the truck has been operating on a “flat”, **do not park the machine inside of a building until the tire cools**. If the tire must be changed, do not stand in front of the rim and locking ring when inflating a tire mounted on the machine. Observers should not be permitted in the area and should be kept away from the side of such tires.



The tire and rim assembly may explode if subjected to excessive heat. Personnel should move to a remote or protected location if sensing excessively hot brakes, smell of burning rubber or evidence of fire near tire and wheel area.

If the truck must be approached to distinguish a fire, those personnel should do so only while facing the tread area of the tire (front or back), unless protected by use of large heavy equipment as a shield. Stay at least 50 ft. (15 m) from the tread of the tire.

In the event of fire in the tire and wheel area (including brake fires), stay away from the truck for at least 8 hours or until the tire and wheel are cool.

- Keep serviceable fire fighting equipment on hand. Report empty extinguishers for replacement or refilling.
- Always have the parking brake applied when the truck is parked and unattended. **DO NOT** leave the truck unattended while the engine is running.
- Park the truck a safe distance away from other vehicles as determined by the supervisor.
- Stay alert at all times! In the event of an emergency, be prepared to react quickly and avoid accidents. If an emergency arises, know where to get prompt assistance.

Check When Traveling In Reverse

Before operating the machine or work equipment, do as follows:

- Sound the horn to warn people in the area. For machines equipped with a back-up alarm, ensure the alarm works properly.
- Check for personnel near the machine. Be particularly careful to check behind the machine.
- When necessary, designate a person to watch the area near the truck and signal the operator. This is particularly necessary when traveling in reverse.
- When operating in areas that may be hazardous or have poor visibility, designate a person to direct work site traffic.
- Do not allow any one to enter the line of travel of the machine. This rule must be strictly observed even with machines equipped with a back-up alarm or rear view mirror.

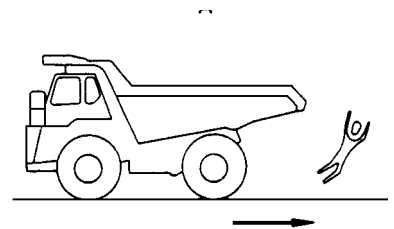

Traveling

- When traveling on rough ground, travel at low speeds. When changing direction, avoid turning suddenly.
- Lower the dump body and set the dump lever to the FLOAT position before traveling.
- If the engine should stop when the machine is in motion, the emergency steering system will be activated. Apply the brakes immediately and stop the machine as quickly and safely as possible (off of the haul road, if possible).

WHEN REPAIRS ARE NECESSARY

1. Only qualified maintenance personnel who understand the systems being repaired should attempt repairs.
2. Many components on the Komatsu truck are large and heavy. Insure that lifting equipment - hoists, slings, chains, lifting eyes - are of adequate capacity to handle the lift.
3. Do not under a suspended load. Do not work under raised body unless body safety cables, props, or pins are in place to hold the body in up position.
4. Do not repair or service the truck while the engine is running, except when adjustments can only be made under such conditions. **Keep a safe distance from moving parts.**
5. When servicing any air conditioning system with refrigerant, wear a face shield and cold resistant gloves for protection against freezing. Be certain to follow all current regulations for handling and recycling refrigerants.
6. Follow package directions carefully when using cleaning solvents.
7. If an auxiliary battery assist is needed, first use one cable to connect the 24V positive (+) post of the disabled truck batteries to the 24V positive (+) post of the auxiliary assist. Use second cable to connect the 24V negative (-) post of the auxiliary assist battery to **a frame ground (-)** on the disabled truck away from the battery.
8. Always disconnect the positive and negative battery cables of the vehicle before doing any welding on the unit. Failure to do so may seriously damage the battery and electrical equipment. Disconnect battery charging alternator lead wire and isolate electronic control components before making welding repairs. (It is not necessary to disconnect or remove any control circuit cards on electric drive dump trucks or any of the "AID" circuit control cards.)
Always fasten the welding machine ground (-) lead to the piece being welded; **the grounding clamp must be attached as near as possible to the weld area.** Never allow welding current to pass through ball bearings, roller bearings, suspensions, or hydraulic cylinders. Always avoid laying welding cables over or near the vehicle electrical harnesses. Welding voltage could be induced into the electrical harness and possibly cause damage to components.
9. If the truck is to be towed for any reason, use a rigid tow bar. Check truck cab for decal recommending special towing precautions. (Also refer to the Operation and Maintenance Manual, Operating Instructions - Towing .)
10. Drain, clean and ventilate fuel tanks and/or hydraulic tanks before making any welding repairs.

WARNING

Any operating fluid, such as hydraulic oil or brake fluid escaping under pressure, can have sufficient force to enter a person's body by penetrating the skin. Serious injury and possibly death may result if proper medical treatment by a physician familiar with this injury is not received immediately.

11. Relieve pressure in lines or hoses before making any disconnects.
12. After adjustments or repairs, replace all shields, screens and clamps.
13. Tire Care:

WARNING

Do not stand in front of a rim and locking ring when inflating a tire mounted on the machine. Observers should not be permitted in the area and should be kept away from the sides of such tires.

Do not weld or apply heat on the rim assembly with the tire mounted on the rim. Resulting gases inside the tire may ignite, causing explosion of tire and rim.

14. Only a qualified operator or experienced maintenance personnel who are also qualified in operation should move the truck under its own power in the repair facility or during road testing after repairs are complete.

This caution decal is placed on the back of the control cabinet to alert service technicians that this area contains capacitors and must not be disturbed in any manner.

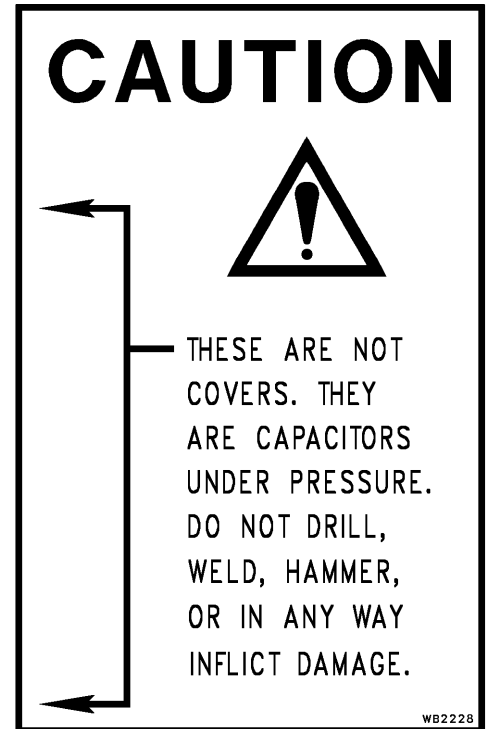

This information decal is placed on the outside of the door panel on the control cabinet wall that faces the right side of the operator cab.

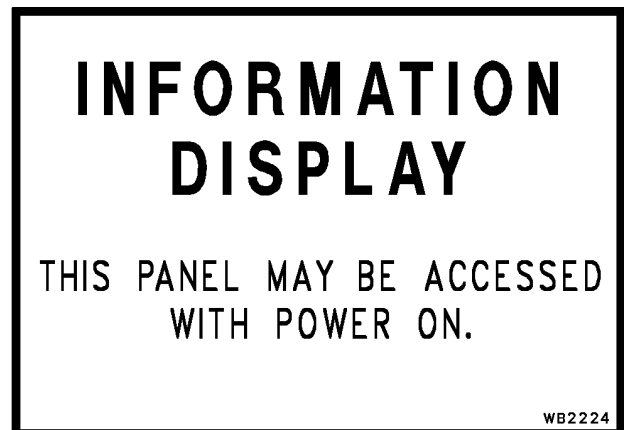

This decal is placed near three different indicator lights:

- In the operator cab, on the D.I.D. panel on the rear wall.
- On the front of the control box which is mounted on the right side of the main control cabinet.
- On the outside of the left control cabinet wall that faces the right side of the operator cab. (See also Information decal above.)

When any of these indicator lights are on, high voltage is present throughout the propulsion and retarding system. Extreme care should be exercised!

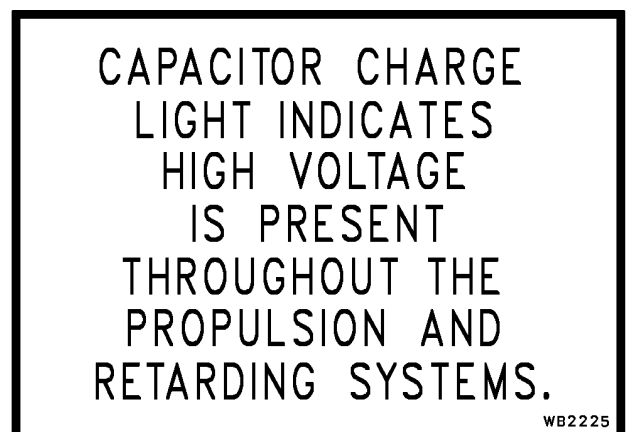

6. Maintain a safe distance when following another vehicle. Never approach another vehicle from the rear, in the same lane, closer than 50 ft. (15 m). When driving on a down grade, this distance should not be less than 100 ft. (30 m).
7. Do not stop or park on a haul road unless unavoidable. If you must stop, move truck to a safe place, apply parking brake, and shut down engine before leaving cab. Block wheels securely and notify maintenance personnel for assistance.
8. Before starting up or down a grade, maintain a speed that will insure safe driving and provide effective retarding under all conditions (Refer to Operator Cab and Controls - Dynamic Retarding. The grade/speed retard chart in the operator's cab should always be referenced to determine maximum safe truck speeds for descending various grades with a loaded truck.
9. When operating truck in darkness, or when visibility is poor, do not move truck unless all headlights, clearance lights, and tail lights are on. Do not back truck if back-up horn or lights are inoperative. Always dim headlights when meeting oncoming vehicles.
10. If the "emergency steering" light and/or "low brake pressure warning" light (if equipped) illuminate during operation, steer the truck **immediately** to a safe stopping area, away from other traffic if possible. Refer to item 7 above.
11. Check tires for proper inflation periodically during shift. If truck has been run on a "flat", or under-inflated tire, it must not be parked in a building until the tire cools.

STARTING ON A GRADE WITH A LOADED TRUCK

Initial propulsion with a loaded truck should begin from a level surface whenever possible. There are circumstances when starting on a hill or grade cannot be avoided; use the following procedure:

1. Fully depress the foot-operated retarder/service brake pedal (Do Not use retarder lever) to hold the truck on the grade. With service brakes fully applied, move the selector switch to a drive position (FORWARD/ REVERSE) and increase engine rpm with throttle pedal.
2. As engine rpm approaches maximum, and operator senses propulsion effort working against the brakes, release the brakes and let truck movement start. Be sure to completely release the foot-operated retarder/service brake pedal. As truck speed increases above 3-5 mph (5-8 kph) the Propulsion System Control (PSC) will drop propulsion, if the retarder is still applied.

Releasing and reapplying dynamic retarding during a hill start operation will result in loss of propulsion.

PASSING

1. Do not pass another truck on a hill or blind curve!
2. Before passing, make sure the road ahead is clear. If a disabled truck is blocking your lane, slow down and pass with extreme caution.
3. Use only the areas designated for passing.

LOADING

1. Pull into the loading area with caution. Remain at a safe distance while truck ahead is being loaded.
2. Do not drive over unprotected power cables.
3. When approaching or leaving a loading area, watch out for other vehicles and for personnel working in the area.
4. When pulling in under a loader or shovel, follow "spotter" or "shovel operator" signals. The truck operator may speed up loading operations by observing the location and loading cycle of the truck being loaded ahead, then follow a similar pattern.
5. During loading, the operator must stay in the truck cab with engine running. Place the selector switch in NEUTRAL and apply the brake lock.
6. When loaded, pull away from shovel as quickly as possible but with extreme caution.

Retarder Control Lever

Retarder control lever (6, Figure 32-2) mounted on the right side of the steering column can be used to modulate retarding effort. The lever will command the full range of retarding and will remain at a fixed position when released.

- When the lever is rotated to full "up" (counterclockwise) position, it is in the OFF/no retard position. An adjustable detent holds the lever in the OFF position. Refer to Section J in the service manual for adjustment procedures.
- When the lever is rotated to full "down" (clockwise) position, it is in the full ON/retard position.
- For long downhill hauls, the lever may be positioned to provide desired retarding effort, and it will remain where it is positioned.

NOTE: The retarder control lever must be rotated back to the OFF position before the truck will resume the propel mode of operation.

The lever and foot-operated retarder/service brake pedal can be used simultaneously or independently. The Propulsion System Controller (PSC) will determine which device is requesting the most retarding effort and apply that amount.

Dynamic Retarder/Service Brake Pedal

Dynamic retarder/service brake pedal (3, Figure 32-1) is a single, foot-operated pedal that controls both retarding and service brake functions. The first portion of pedal travel commands retarding effort through a rotary potentiometer. The second portion of pedal travel modulates service brake pressure directly through a hydraulic valve. Thus, the operator must first apply, and maintain, full dynamic retarding in order to apply the service brakes. Releasing the pedal returns brake and retarder to the OFF position.

When the pedal is partially depressed, the dynamic retarding is actuated. As the pedal is further depressed, to where dynamic retarding is fully applied; the service brakes (while maintaining full retarding) are actuated through a hydraulic valve which modulates pressure to the service brakes. **Completely depressing the pedal causes full application of both dynamic retarding and the service brakes.** An indicator light in the overhead panel (B3, Figure 32-8) will illuminate, and an increase in pedal resistance will be felt when the service brakes are applied.

For normal truck operation, **dynamic retarding** (lever or foot-operated pedal) **should be used to slow and control the speed of the truck.**

Service brakes should be applied only when dynamic retarding requires additional braking force to slow the truck speed quickly, or **when bringing the truck to a complete stop.**

Accelerator (Throttle) Pedal

The accelerator (throttle) pedal (4, Figure 32-1) is a foot-operated pedal which allows the operator to control engine rpm, depending on pedal depression.

It is used by the operator to request torque from the motors when in forward or reverse. In this mode, the propulsion system controller commands the correct engine speed for the power required. In NEUTRAL, this pedal controls engine speed directly.

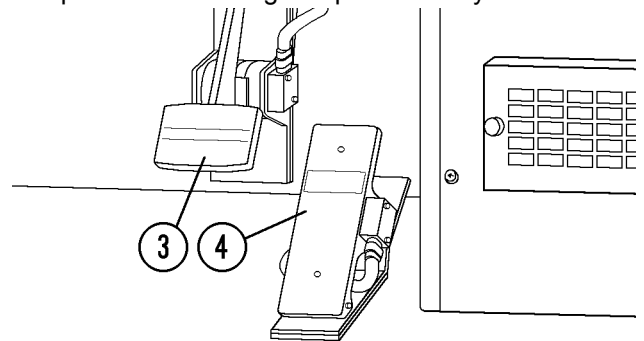

Starting on a Grade With a Loaded Truck

Initial propulsion with a loaded truck should begin from a level surface whenever possible, but when there are circumstances where starting on a hill or grade cannot be avoided, use the following procedure:

- Fully depress the foot-operated retarder/service brake pedal (Do Not use retarder lever) to hold the truck on the grade. With service brakes fully applied, move the selector switch to a drive position (FORWARD/REVERSE) and increase engine rpm with throttle pedal.
- As engine rpm approaches maximum, and operator senses propulsion effort working against the brakes, release the brakes and let truck movement start. Be sure to completely release the foot-operated retarder/service brake pedal. As truck speed increases above 3-5 mph (5-8 kph) the Propulsion System Control (PSC) will drop propulsion if the retarder is still applied.

Releasing and reapplying dynamic retarding during a hill start operation will result in loss of propulsion and, if truck speed is above 1-2 mph, application of retarding effort.

CLICK HERE TO **DOWNLOAD** THE COMPLETE MANUAL

- Thank you very much for reading the preview of the manual.
- You can download the complete manual from: www.heydownloads.com by clicking the link below



- Please note: If there is no response to CLICKING the link, please download this PDF first and then click on it.

CLICK HERE TO **DOWNLOAD** THE COMPLETE MANUAL

INSTRUMENT PANEL AND INDICATOR LIGHTS

CONTROL SYMBOLS

Many control functions are identified with international symbols that the operator should learn to recognize immediately. The operator must understand the function and operation of each instrument and control. This knowledge is essential for proper and safe operation of the machine.

The following symbols are general indicators and may appear in multiple locations and combinations on the instrument panel.

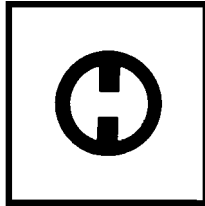

This symbol may be used alone or with another symbol. This symbol identifies the OFF position of a switch or control.

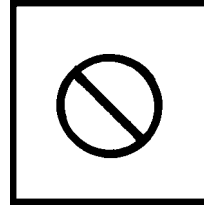

This symbol when it appears on an indicator or control identifies that this indicator or control is NOT used.

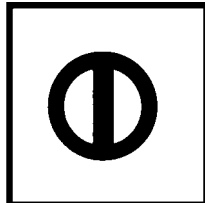

This symbol may be used alone or with another symbol. This symbol identifies the ON position of a switch or control.

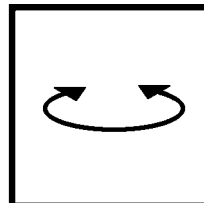

This symbol identifies a rotary control or switch. Rotate the knob clockwise or counterclockwise for functions.

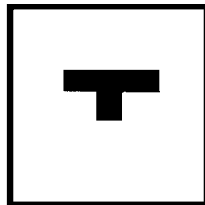

This symbol identifies the "Pushed-In" position of a push-pull switch or control.

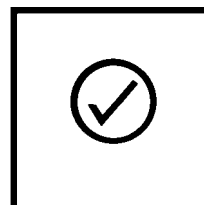

This symbol identifies a switch used to test or check a function. Press the switch on the side near the symbol to perform the test.



This symbol identifies the "Pulled-Out" position of a push-pull switch or control.

INSTRUMENT PANEL

(Figure 32-7)

The operator must understand the function and operation of each instrument and control. Control functions are identified with "international" symbols that the operator should learn to recognize immediately. This knowledge is essential for proper and safe operation.

Items that are marked "optional" do not apply to every truck.

C1. Low Accumulator Precharge Pressure

The low accumulator precharge warning light, if illuminated, indicates low nitrogen precharge for the steering accumulator(s). To check for proper accumulator nitrogen precharge, engine must be stopped and hydraulic system completely bled down; turn keyswitch to RUN position. The warning light will *not* illuminate if system is properly charged. The warning light will flash if the nitrogen precharge within the accumulator(s) is below 1100 ± 45 psi (7585 ± 310 kPa).

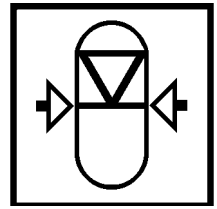

If low accumulator precharge warning light flashes, notify maintenance personnel. Do not attempt further operation until the accumulators have been recharged with nitrogen to 1400 psi (9653 kPa). Sufficient energy for emergency steering may not be available, if system is not properly charged.

D1. Electric System Fault

This light is reserved for future use by the AC drive system.

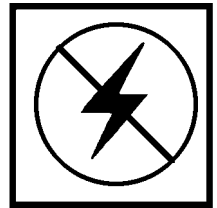
**E1. Low Brake Pressure**

This red indicator light indicates a malfunction within the hydraulic brake circuit. If this light comes on and buzzer sounds, **shut down truck operation** and notify maintenance personnel.

NOTE: Adequate hydraulic fluid is stored to allow the operator to safely stop the truck.

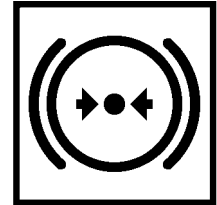
**A2. Low Hydraulic Tank Level**

This warning light indicates the oil level in the hydraulic tank is below recommended level. Damage to hydraulic pumps may occur if operation continues. Shut truck down and notify maintenance personnel immediately.

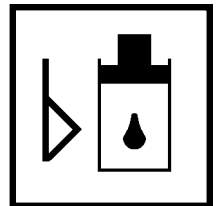
**B2. Low Automatic Lubrication System Pressure**

This amber light will illuminate if the automatic lubrication system fails to reach 2,200 PSI (at the junction block located on the rear axle housing) within one minute after the lube timer initiates a cycle of grease. To turn the light off, turn key switch OFF, then back to ON again. Notify maintenance personnel at earliest opportunity after light comes on.

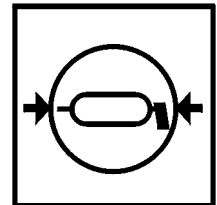
**C2. Circuit Breaker Tripped**

This light will illuminate if any of the circuit breakers in the relay circuit control boards are tripped. The relay circuit boards are located in the electrical control cabinet.

NOTE: Additional circuit breakers are in the operator cab behind the center console, however tripping of these circuit breakers should not activate this light.

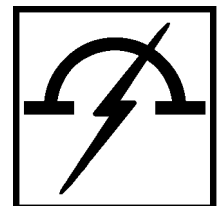

10 HOUR (DAILY) INSPECTION (Continued)

| Truck Serial Number _____ Site Unit Number _____ Date _____ | | | |
|---|----------|---------|----------|
| Hourmeter _____ Name of Service Technician _____ | | | |
| TASK | COMMENTS | CHECKED | INITIALS |
| 8. AIR INTAKE PIPING - Check all mounting hardware, joints, and connections. Ensure no air leaks exist and all hardware is properly tightened. Figure 40-2. | | | |
| 9. AIR CLEANERS - Check the air cleaner vacuum gauges in the operator cab, Figure 40-3. The air cleaner(s) should be serviced if the gauge(s) shows the following maximum restriction: Komatsu SSDA16V160 Engine: 25 in. of H ₂ O vacuum. Refer to Section C in the shop manual for servicing instructions for the air cleaner elements. Empty the air cleaner dust caps. <i>NOTE: After service, push the reset button on face of gauge to allow the gauge to return to zero.</i> | | | |
| 10. CAB AIR FILTER - Under normal operating conditions, clean every 250 hours. In extremely dusty conditions, service as frequently as required. Clean the filter element with mild soap and water. Rinse completely clean and air dry with a maximum of 40 psi (275 kPa). Reinstall the filter. Refer to Figure 40-4. | | | |

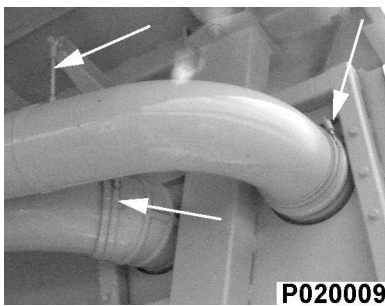

FIGURE 40-2.

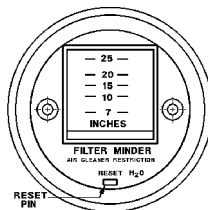

FIGURE 40-3.



FIGURE 40-4.

1. Filter Cover

2. Cab Filter

AUTOMATIC LUBRICATION SYSTEM

GENERAL DESCRIPTION

The Lincoln Automatic Lubrication System is a pressurized lubricant delivery system which delivers a controlled amount of lubricant to designated lube points. The system is controlled by an electronic timer which signals a solenoid valve to operate a hydraulic motor powered grease pump. Hydraulic oil for pump operation is supplied by the truck steering circuit.

Grease output is proportional to the hydraulic motor input flow. A pump control manifold, mounted on top of the hydraulic motor, controls input flow and pressure. A 24VDC Solenoid mounted on the manifold turns the pump on and off.

The pump is driven by the rotary motion of the hydraulic motor, which is then converted to reciprocating motion through an eccentric crank mechanism. The reciprocating action causes the pump cylinder to move up and down. The pump is a positive displacement, double-acting type as grease output occurs on both the up and the down stroke.

During the down stroke, the pump cylinder is extended into the grease. Through the combination of shovel action and vacuum generated in the pump cylinder chamber, the grease is forced into the pump cylinder. Simultaneously, grease is discharged through the outlet of the pump. The volume of grease during intake is twice the amount of grease output during one cycle. During the upstroke, the inlet check valve closes, and one half the grease taken in during the previous stroke is transferred through the outlet check and discharged to the outlet port.

WARNING

Over-pressurizing of the system, modifying parts, using incompatible chemicals and fluids, or using worn or damaged parts, may result in equipment damage and/or serious personal injury.

- **DO NOT exceed the stated maximum working pressure of the pump, or of the lowest rated component in the system.**
- **Do not alter or modify any part of this system unless approved by factory authorization.**
- **Do not attempt to repair or disassemble the equipment while the system is pressurized.**
- **Make sure all fluid connections are securely tightened before using this equipment.**
- **Always read and follow the fluid manufacturer's recommendations regarding fluid compatibility, and the use of protective clothing and equipment.**
- **Check all equipment regularly and repair, or replace, worn or damaged parts immediately.**

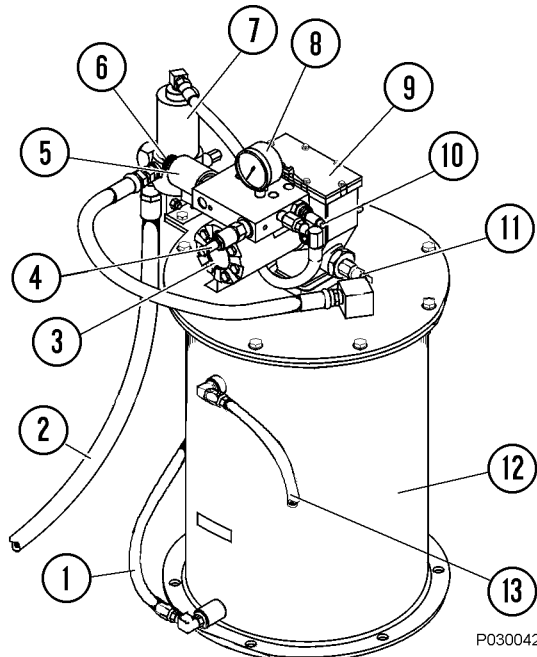

FIGURE 42-1. PUMP & RESERVOIR COMPONENTS

- | | |
|----------------------------|------------------------|
| 1. Hose From Filter | 7. Vent Valve |
| 2. Outlet to Injectors | 8. Pressure Gauge |
| 3. Hydraulic Motor | 9. Pump Assembly |
| 4. Pressure Reducing Valve | 10. Flow Control Valve |
| 5. Solenoid Valve | 11. Pressure Switch |
| 6. Manual Override Switch | 12. Grease Reservoir |
| | 13. Vent Hose |

This equipment generates very high grease pressure. Extreme caution should be used when operating this equipment as material leaks from loose or ruptured components can inject fluid through the skin and into the body causing serious bodily injury including possible need for amputation. Adequate protection is recommended to prevent splashing of material onto the skin or into the eyes.

If any fluid appears to penetrate the skin, get emergency medical care immediately! Do not treat as a simple cut. Tell attending physician exactly what fluid was injected.

SYSTEM TROUBLESHOOTING CHART

If the following procedures do not correct the problem, contact a factory authorized service center.

| TROUBLE | POSSIBLE CAUSES | SUGGESTED CORRECTIVE ACTION |
|--|--|---|
| Pump Does Not Operate | Lube system not grounded. | Correct grounding connections to pump assembly and truck chassis. |
| | Electrical power loss. | Locate cause of power loss and repair. 24 VDC power required. Be sure keyswitch is "ON". |
| Pump Does Not Operate | Timer malfunction. | Replace timer assembly |
| | Solenoid valve malfunctioning. | Replace the solenoid valve assembly |
| | Relay malfunctioning | Replace relay |
| | Motor or pump malfunction. | Repair or replace motor and/or pump assembly. (Refer to Service Manual for rebuild instructions.) |
| <i>NOTE: On initial startup of the lube system, the timing capacitor will not contain a charge, therefore the first timing cycle will be about double in length compared to the normal interval. Subsequent timer cycles should be as specified.</i> | | |
| Pump Will Not Prime | Low lubricant supply. | Dirt in reservoir, pump inlet clogged, filter clogged. |
| Pump Will Not Build Pressure | Air trapped in lubricant supply line. | Prime system to remove trapped air. |
| | Lubricant supply line leaking. | Check lines and connections to repair leakage. |
| | Vent valve leaking. | Clean or replace vent valve. |
| | Pump worn or scored. | Repair or replace pump assembly. (Refer to Service Manual for rebuild instructions.) |
| Injector Indicator Stem Does Not Operate | <i>NOTE: Normally, during operation, the injector indicator stem will move into the body of the injector when pressure builds properly. When the system vents (pressure release) the indicator stem will again move out into the adjusting yoke.</i> | |
| | Malfunctioning injector - usually indicated by the pump building pressure and then venting. | Replace individual injector assembly. |
| Injector Indicator Stem Does Not Operate | All injectors inoperative - pump build up not sufficient to cycle injectors. | Service and/or replace pump assembly. (Refer to Service Manual for rebuild instructions.) |
| | <i>NOTE: Normally, during operation, the injector indicator stem will move into the body of the injector when pressure builds properly. When the system vents (pressure release) the indicator stem will again move out into the adjusting yoke.</i> | |
| Pressure Gauge Does Not Register Pressure | No system pressure to the pump motor. | Check hydraulic hose from steering system. |
| | No 24 VDC signal at pump solenoid. | Determine problem in 24 VDC electric system. |
| | Pressure reducing valve set too low. 24V Relay (RB7, K5) may be defective. | Refer to "Pressure Control Valve Adjustment". Replace relay. |

OPERATION SECTION

Introduction

Payload Meter III (PLMIII) measures, displays and records the weight of material being carried by an off-highway truck. The system generally consists of a payload meter, a gauge display, deck-mounted lights, and sensors. The primary sensors are four suspension pressures and an inclinometer. Other inputs include a body up signal, brake lock signal, and speed.

Data Summary

5208 haul cycles can be stored in memory. The following information is recorded for each haul cycle:

- Payload
- Operator ID number (0000-9999)
- Distance traveled loaded and empty
- The amount of time spent empty run/stop, loading, loaded run/stop, and dumping
- Maximum speed loaded and empty with time of day
- Average speed loaded and empty
- Empty carry-back load
- Haul-cycle, loading, dumping start time of day.
- Peak positive and peak negative frame torque with time of day
- Peak sprung load with time of day
- Tire ton-mph for each front and average per rear tires

The payload meter stores lifetime data that cannot be erased. This data includes:

- Top 5 maximum payloads and time stamps.
- Top 5 positive and negative frame torque and time stamps
- Top 5 maximum speeds and time stamps

Data Gathering

Windows 95/98/NT software is available to download, store and view payload and fault information. The PC software will download an entire truck fleet into one Paradox database file. Users can query the database by date, time, truck type and truck number to produce reports, graphs and export the data. The software can export the data in '.CSV' format that can be easily imported into most spreadsheet applications. The Windows software is not compatible with the Payload Meter 2 system.

It is important that each payload meter be configured for each truck using the PC software. The information for frame serial number and truck number is used by the database program to organize the payload data. In addition, the payload meter must be configured to make calculations for the proper truck model. Improper configuration can lead to data loss and inaccurate payload calculations.

Haul Cycle Data

The following information is recorded for each haul cycle:

| Table 1. Haul Cycle Data | | |
|---------------------------------|---------------|--|
| Data | Unit | Remark |
| Truck # | alpha-numeric | Up to 22 characters can be stored in this field to identify the truck. Typically this field will be just the truck number. |
| Haul Cycle Start Date/Time | seconds | Number of seconds from 1/1/70 to the start of the haul cycle, haul cycle starts when the meter transitions from dumping to empty state after the previous haul cycle, download program converts seconds into date and time for display |
| Payload | tons | Stored as metric, download program allows for conversion to short or long tons. |
| Number of Swingloads | number | The number of swingloads detected by the payload meter |
| Operator ID | number | This is a 4 digit number that can be entered by the operator at the start of the shift. |
| Warning Flags | alpha | Each letter represents a particular warning message about the haul cycle, details are located on page 19. |
| Carry-back load | tons | The difference between the latest empty tare and the clean truck tare |
| Empty haul time | seconds | Number of seconds in the tare_zone and empty states with the truck moving |
| Empty stop time | seconds | Number of seconds in the tare_zone and empty states with the truck stopped |
| Loading time | seconds | Number of seconds in the loading state |
| Loaded haul time | seconds | Number of seconds in the maneuvering, final_zone and loaded states with the truck moving |
| Loaded stop time | seconds | Number of seconds in the maneuvering, final_zone and loaded states with the truck stopped |
| Dumping time | seconds | Number of seconds in the dumping state |
| Loading start time | seconds | Number of seconds from the start of the haul cycle to when the meter transitions from empty to loading state |
| Dump start time | seconds | Number of seconds from the start of the haul cycle to the time when the meter switches from loaded to dumping state |
| Loaded haul distance | m | Distance traveled while loaded |
| Empty haul distance | m | Distance traveled while empty |
| Loaded max speed | km/h | Maximum speed recorded while the truck is loaded |
| Loaded max speed time | seconds | Number of seconds from the start of the haul cycle to the time when the max speed occurred |
| Empty max speed | km/h | Maximum speed recorded while the truck is empty |
| Empty max speed time | seconds | Number of seconds from the start of the haul cycle to the time when the max speed occurred |
| Peak positive frame torque | ton-meter | Positive frame torque is measured as the frame twists in the clockwise direction as viewed from the operator's seat. |
| Peak frame torque time | seconds | Number of seconds from the start of the haul cycle to the peak torque, download program converts to time for display |
| Peak negative frame torque | ton-meter | Negative frame torque is measured as the frame twists in the counter-clockwise direction as viewed from the operator's seat. |
| Peak frame torque time | seconds | Number of seconds from the start of the haul cycle to the peak torque, download program converts to time for display |
| Peak sprung load | tons | Peak dynamic load calculation |
| Peak sprung load time | seconds | Number of seconds from the start of the haul cycle to the peak instantaneous load calculation |
| Front-left tire-ton-km/h | t-km/h | Tire ton-km/h for haul cycle |
| Front-right tire-ton-km/h | t-km/h | Tire ton-km/h for haul cycle |
| Average rear tire-ton-km/h | t-km/h | Tire ton-km/h for haul cycle |
| Truck Frame Serial Number | alpha | The truck serial number from the nameplate on the truck frame |
| Reserved 1-10 | number | These values are internal calculations used in the continued development of the PLMIII system and should be ignored |

Sorting on Date Range

The default query starts in 1995 and runs through the current date on the PC. To narrow the range to a specific date, change the "From" and "To" dates.

For example, to view the haul cycle reports from truck 374 for the month of July, 2000:

1. Select truck 374 from the Truck Unit pull-down menu.

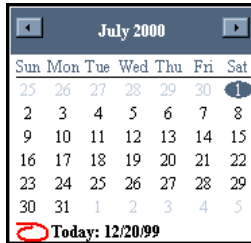

2. Change the "From" date to July 1, 2000.

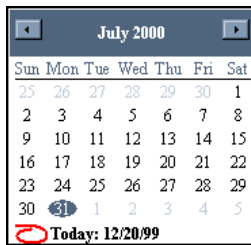

3. Change the "To" date to July 31, 2000.
4. Press the "Query Database and Display" to view the results.

Sorting on Time Range

The time range sorts the times of the day for valid dates. Changing the time range to 6:00AM to 6:00PM will limit the payloads displayed to the loads that occurred between those times for each day of the date range. Times are entered in 24:00 format. To view the haul cycle reports from the first shift for truck 374 from January 5, 2000 to January 8, 2000:

1. Select truck 374 from the Truck Unit pull-down menu.



2. Change the "From" date to July 1, 2000.

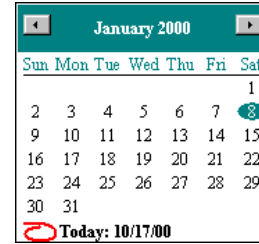

3. Change the "To" date to July 31, 2000.
4. Change the "From" time to 06:00.
5. Change the "To" time to 18:00.

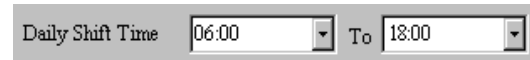

6. Press the "Query Database and Display" to view the results.

This query will display haul cycles from January 5 to January 8, from 6:00 AM to 6:00 PM.

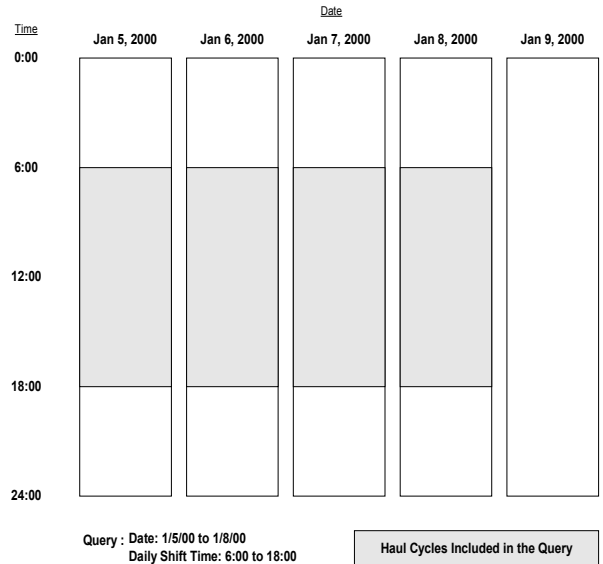

The shift times selected can extend the query past the original date. If the dates set for the query are January 5 to January 8 and the times were changed to query the 6:00 PM (18:00) to 6:00 AM (06:00) shift, the results would extend into the morning of the 9th. This can be seen in the following example:

CLICK HERE TO **DOWNLOAD** THE COMPLETE MANUAL

- Thank you very much for reading the preview of the manual.
- You can download the complete manual from: www.heydownloads.com by clicking the link below



- Please note: If there is no response to CLICKING the link, please download this PDF first and then click on it.

CLICK HERE TO **DOWNLOAD** THE COMPLETE MANUAL