

Operation & Maintenance Manual

330M

DUMP TRUCK

SERIAL NUMBERS **A10190 - A10211**

KOMATSU[®]

CLICK HERE TO **DOWNLOAD** THE COMPLETE MANUAL

- Thank you very much for reading the preview of the manual.
- You can download the complete manual from: www.heydownloads.com by clicking the link below



- Please note: If there is no response to CLICKING the link, please download this PDF first and then click on it.

CLICK HERE TO **DOWNLOAD** THE COMPLETE MANUAL

About This Manual

This Manual is written for use by the operator and/or the service technician and is designed to help these persons to become fully knowledgeable of the truck and all its systems in order to keep it operating safely and efficiently. All operators and maintenance personnel should read and understand the materials in this manual before operating the truck or performing maintenance and/or operational checks on the truck. All safety notices, warnings, and cautions should be understood and followed when operating or accomplishing repairs on the truck.

The front cover of this manual includes a Form Number. This Form No. should be referenced when ordering additional copies of this manual, or for any other correspondence regarding the coverage in this manual.

Direct all inquiries to:

Komatsu America Corp.
Datakom, Peoria Technical Publications
P.O. Box 240
Peoria, IL 61650-0240
(309)-672-7072 - FAX

This first section is an Introduction to the manual and contains a Table of Contents to locate specific areas of interest. Other sections include Safety, Operation, Maintenance, Specifications, and Optional Equipment.

When searching for a specific area of interest, go first to the Table of Contents to locate the Section in which the subject might generally be included. Then, go to that Section of the Table of Contents to find a Subject description that most closely describes the specific area of interest to find a page number and go to that page. Section Numbers and Page Numbers are located at the top, outside corner of the page.

At the top, inside corner of the page is a document (module) number. If there is ever a question regarding the information in a particular Section, refer to the document (module) number, the manual Form No., and use the address shown above to correspond. If there is a date (month/year) behind the document (module) number, that indicates the latest revision date of that page.

The illustrations used in this manual are TYPICAL of the component shown and may not be an exact reproduction of what is found on the truck.

This manual shows dimensioning of metric and (U.S. standard) units throughout. All references to "Right", "Left", "Front", or "Rear" are made with respect to the operator's normal seated position, unless specifically stated otherwise.

When assembly instructions are provided without references to torque values, standard torque values should be assumed. Standard torque requirements are shown in torque charts on the following pages of this section, and in the General Information section of the truck service manual. Individual torques when provided in the text are in bold face type, such as **723 kg.m (100 ft.lbs.)** torque. All torque specifications have $\pm 10\%$ tolerance unless otherwise specified.

PRECAUTIONS WHEN HANDLING AT HIGH TEMPERATURES

- Immediately after operations, the engine cooling water, engine oil, and hydraulic oil are at high temperature and are under pressure. If the cap is removed, or the oil or water is drained, or the filters are replaced, there is danger of serious burns. Always wait for the temperature to cool down, and carry out the operation according to the specified procedure.
- To prevent hot water from spurting out:
 - 1) Stop the engine.
 - 2) Wait for the water temperature to cool down.
 - 3) Turn the cap slowly to release the pressure before removing the cap.
- To prevent hot engine oil from spurting out:
 - 1) Stop the engine.
 - 2) Wait for the oil temperature to cool down.
 - 3) Turn the cap slowly to release the pressure before removing the cap.

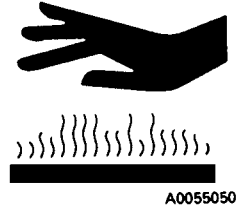

ASBESTOS DUST HAZARD PREVENTION

Asbestos dust can be HAZARDOUS to your health if it is inhaled. If you handle materials containing asbestos fibers, follow these guidelines as given below:

- NEVER use compressed air for cleaning.
- Use water for cleaning to keep down the dust.
- Operate the machine with the wind to your back, whenever possible.
- Use an approved respirator if necessary.

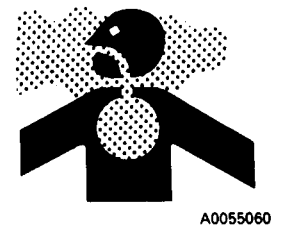

PREVENTION OF INJURY BY WORK EQUIPMENT

- Never enter or put your hand or arm or any other part of your body between movable parts such as the dump body and chassis or cylinders. If the work equipment is operated, the clearance will change and this may lead to serious bodily injury or death.
- Never work or perform maintenance on machine with the body raised off the frame unless body is fully raised, the Safety Pins are installed, and the hoist lever is locked in the HOLD position.

FIRE EXTINGUISHER AND FIRST AID KIT

- Be sure fire extinguishers have been provided and know how to use them.
- Provide a first aid kit at the storage point.
- Know what to do in the event of a fire.
- Be sure you know the phone numbers of persons you should contact in case of an emergency.

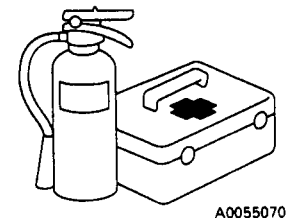

RULES TO FOLLOW WHEN ADDING FUEL OR OIL

- Spilled fuel and oil may cause slipping. Always clean up spills immediately.
- Always tighten the cap of the fuel and oil fillers securely.
- Never use fuel for washing any parts.
- Always add fuel and oil in a well-ventilated place.



A0055020

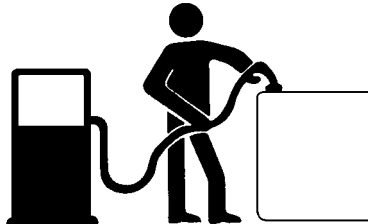

A0055030



A0055040

RADIATOR WATER LEVEL

- If it is necessary to add water to the radiator, stop the engine and allow the engine and radiator to cool down before adding the water.
- Slowly loosen the cap to relieve pressure before removing the cap.

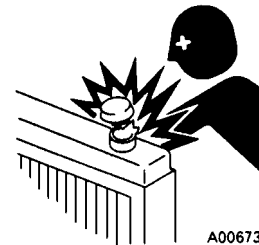

A0067380

USE OF LIGHTING

When checking fuel, oil, coolant, or battery electrolyte, always use lighting with anti-explosion specifications. If such lighting equipment is not used, there is danger of explosion.



A0055160

PRECAUTIONS WITH BATTERY

- When repairing the electrical system or when carrying out electrical welding, remove the negative (-) terminal of the battery to stop the flow of current.



A0055170

HANDLING HIGH-PRESSURE HOSES

- Do not bend high-pressure hoses or hit them with hard objects. Do not use any bent or cracked piping, tubes or hoses. They may burst during use.
- Always repair any loose or broken fuel hoses or oil hoses. If fuel or oil leaks, it may cause a fire.

A Speed/Grade decal showing Retarding Capacities is applied to the lower left-hand corner of the cab windshield. This decal is designed to help the operator maintain a safe vehicle speed while descending a grade with a loaded truck.

The operator should pre-select a ground speed and gear range for a known grade that will permit continuous retarder operation within the LIMITS OF THE CHART.

For efficient retarder operation, the operator should: Maintain engine RPM between 1800 - 2400 RPM MAXIMUM, and Observe the Brake Oil Temperature gauge to make certain the Brake Oil Temperature does not exceed 248°F (120°C).

If the Brake Oil Temperature exceeds this limit, move the transmission range selector lever to a lower gear and use the foot-operated service brakes to reduce the truck ground speed. This will allow the transmission to shift to the next lower gear range for more efficient cooling.

If the Brake Oil Temperature continues to exceed 248°F (120°C), select a safe area out of the way of other traffic, stop the truck, move the transmission range selector lever to the Neutral (N) position, and operate the engine at approximately 1200 RPM until the Brake Oil Temperature gauge registers in the "green" range.



WARNING

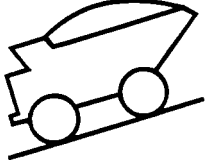

RETARDING CAPACITY
 GVW: 367,000 LBS
 (166,470 kg)
 TIRES: 27 X 49

MAXIMUM BRAKE OIL TEMPERATURE: 248 F (120C)
MAXIMUM ENGINE SPEED: 2400 RPM

**MAINTAIN HIGHEST ENGINE SPEED BELOW MAXIMUM.
 SLOW TO NEXT LOWER GEAR IF COOLING OIL
 TEMPERATURE NEEDS TO BE LOWERED.**

GEAR NUMBER	SPEED MPH (km/hr)	CONTINUOUS GRADE%	SHORT LENGTH 1970ft (600m) GRADE%
1	6.6 (10.6)	28.0	30.4
2	9.3 (15.0)	19.9	22.3
3	12.5 (20.1)	14.8	17.2
4	16.8 (27.1)	11.0	13.4
5	22.7 (36.5)	8.2	10.6
6	30.9 (49.8)	6.0	8.4
7	41.7 (67.1)	4.4	6.8

WB2610

HAULING

1. Always stay alert! If unfamiliar with the road, drive with extreme caution.
2. Govern truck speed by the road conditions, weather and visibility.
3. Operate truck so it is under control at all times.
4. Use extreme caution when approaching a haul road intersection. Maintain a safe distance from oncoming vehicles.
5. Obey all road signs.
6. Always dim headlights when meeting oncoming vehicles.
7. Maintain a safe distance when following another vehicle. Never approach another vehicle from the rear, in the same lane, closer than 15 m (50 ft). When operating on a down grade, stay at least 30 m (100 ft.) away.
8. When operating truck in darkness or when visibility is poor, do not move truck unless headlights are on. Do not back truck if back-up horn or lights are inoperative.
9. When backing the truck, give back-up signal (three blasts on air horn); when starting forward, two blasts on air horn. These signals must be given each time the truck is moved forward or backward.
10. Do not stop or park on a haul road unless unavoidable. If you must stop, move truck to a safe place, apply parking brake, shut down engine, block wheels securely and notify maintenance personnel for assistance.
11. If the "Emergency Steering" light and/or "Low Air Pressure" warning light come on during operation, steer the truck **immediately** to a safe stopping area, away from other traffic if possible. Refer to item 11 above.
12. Report haul road conditions immediately. Muddy or icy roads, pot holes or other obstructions can present hazards.
13. Cab doors should remain closed at all times while truck is in motion or unattended.
14. Check for flat tires periodically during shift. If truck has been run on a "flat", **it must not be parked in a building until the tire cools.**

RETARDER OPERATION

During normal operation, the retarder control lever should be used to control the speed of the truck and to stop the truck instead of using the foot-operated service brake pedal. Use of this lever allows the operator to apply **the REAR oil-cooled brakes only**, thus extending the life of the front caliper disc pads while still maintaining maximum control of the truck. The foot-operated brake pedal should be used when maneuvering in tight places, at the shovel and dump, and when quick stops **or when severe braking is required.**

For better control under slippery road conditions, the **optional** front wheel brake cut-off switch may be turned on (if equipped).

1. Before starting down a grade, maintain a speed that will insure safe operation and provide effective retarding under all conditions.
2. When descending a grade with a loaded truck, the operator should *adjust the speed of the truck*, if necessary, to **preselect a transmission gear range**, so that operation can be maintained within the speeds listed on the **Retarding Capacity** decal located inside the cab on the lower left corner of the front windshield.



WARNING

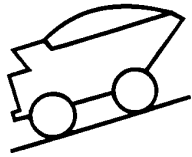

RETARDING CAPACITY
GVW: 367,000 LBS
(166,470 kg)
TIRES: 27 X 49

MAXIMUM BRAKE OIL TEMPERATURE: 248 F (120C)
MAXIMUM ENGINE SPEED: 2400 RPM

MAINTAIN HIGHEST ENGINE SPEED BELOW MAXIMUM.
SLOW TO NEXT LOWER GEAR IF COOLING OIL
TEMPERATURE NEEDS TO BE LOWERED.

GEAR NUMBER	SPEED MPH (km/hr)	CONTINUOUS GRADE%	SHORT LENGTH 1970ft (600m) GRADE%
1	6.6 (10.6)	28.0	30.4
2	9.3 (15.0)	19.9	22.3
3	12.5 (20.1)	14.8	17.2
4	16.8 (27.1)	11.0	13.4
5	22.7 (36.5)	8.2	10.6
6	30.9 (49.8)	6.0	8.4
7	41.7 (67.1)	4.4	6.8

WB2610

Two lists are provided on the **Retarding Capacity** decal, one a continuous rating, and the second a short-length rating. Both lists are matched to the truck at maximum Gross Vehicle Weight.

Emergency Brake Lever (5, Figure 3-2)

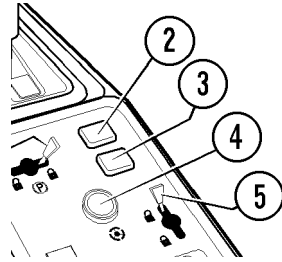
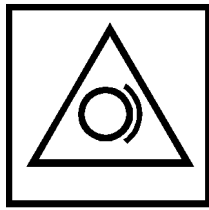

The lever (5) actuates the emergency brake.

EMERGENCY BRAKE RELEASED:
(TRAVEL / UNLOCKED position).



EMERGENCY BRAKE ACTUATED:
(APPLIED / LOCKED position).



- If the pressure in the air tank drops below 411.9 kPa (4.2 kg/cm², 59.7 psi), the emergency brake is automatically applied.
- If the emergency brake is applied because of a failure in the air system, the central warning lamp will flash and the alarm buzzer will sound.

For details of the method of releasing the brake if this happens, see BRAKE RELEASE, Page 3-13.

Parking Brake Valve Lever (6, Figure 3-2)

This lever (6) is used to apply the parking brake.

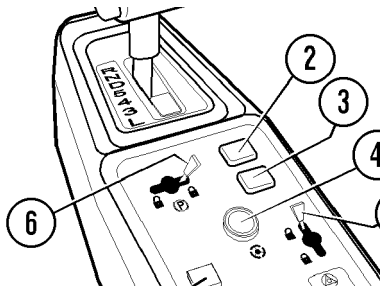
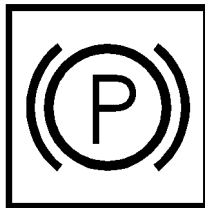

PARKING: Parking Brake actuated. (Locked)



TRAVEL: Parking brake released. (Unlocked)



- When the lever is set to the PARKING position, the parking brake pilot lamp lights up.



Always apply the parking brake when parking or leaving the machine.

- When the lever is set to the PARKING position, if the transmission shift lever is at any position other than "N", the central warning lamp will flash and the alarm buzzer will sound.
- If the air pressure drops below 215.7 kPa (2.2 kg/cm², 31.2 psi), the parking brake is automatically applied.

For details of the method of releasing the brake when it is applied because of failure in the air system, see BRAKE RELEASE.

ENGINE ELECTRONIC CONTROL SYSTEM

The following items (7, 8, 9, 11, & 12, Figure 3-2) relate to the engine electronic fuel control system.

If an abnormal engine condition develops, the control system will record a "fault" code associated with that condition. By use of a series of indicator lamps and switches, the system will display the numerical "fault" code.

When the keyswitch is turned "On", the lamps (7, 8, 9) should illuminate for about 2 seconds and then turn "Off", if no "faults" are detected in the system. This is a system lamp test.

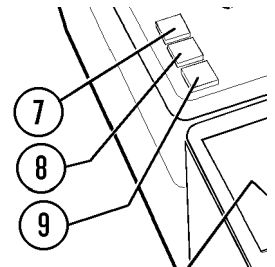

If a light remains ON, or if a light FLASHES, then active "faults" have been detected by the system and the engine should not be started until the condition has been corrected.

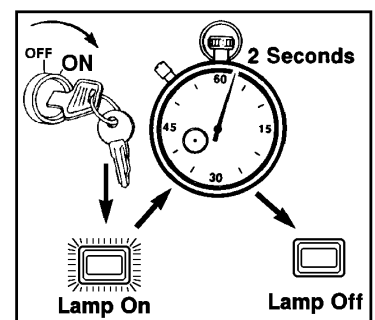

Refer to DETERMINING "FAULT" CODES.

During engine operation, if a "fault" is detected in the system, a light associated with that condition will turn "ON" and stay on for "Warning faults", or it will turn "ON" and "FLASH" for more severe faults that can affect engine operation and require immediate attention.

CLICK HERE TO **DOWNLOAD** THE COMPLETE MANUAL

- Thank you very much for reading the preview of the manual.
- You can download the complete manual from: www.heydownloads.com by clicking the link below



- Please note: If there is no response to CLICKING the link, please download this PDF first and then click on it.

CLICK HERE TO **DOWNLOAD** THE COMPLETE MANUAL

15. Lock-up Pilot Lamp

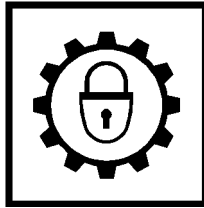

The Lock-Up Pilot Lamp (15, Figure 3-6) lights up whenever the torque converter is locked up and the transmission enters direct drive.

16. Transmission Shift Position Pilot Lamp

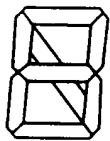

The Transmission Shift Position Pilot Lamp (16) will indicate the specific gear range *in which the transmission is actually operating*; R, N, 1, 2, 3, 4, 5, 6, or 7.

GEAR



17. Shift Indicator



The Shift Indicator (17) indicates the *lever position of the transmission range selector*.

18. Engine Controller Monitor

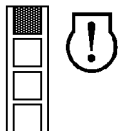

This red indicator (18) flashes whenever any abnormality occurs in any of the engine control systems. NOT USED with SA12V140Z-1 engine.

19. Automatic Transmission Mecha- tronics Monitor

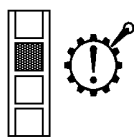

This red indicator (19) flashes whenever any abnormality occurs in the mechatronics related parts of the transmission control system.

20. Other Mechatronics Monitor (OPTIONAL)

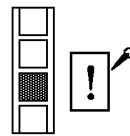

This red indicator (20) flashes whenever any abnormality occurs in the mechatronics related parts of the PMC (Powertrain Management Control) system, PLM (Payload Meter) system, and the optional suspension control system.

21. Fuel Level Monitor

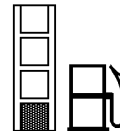

This indicator (21) flashes when the remaining fuel in the fuel tank goes below 170 liters (45 gal). If it flashes, check the fuel level and add fuel.

22. Fuel Gauge

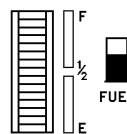

The Fuel Gauge (22) indicates the amount of fuel in the fuel tank. If there is more than 170 liters (45 gal) of fuel in the tank while the engine is operating, the green range lights. If there is less than 170 liters (45 gal) of fuel in the tank, the red range lights.

23, 24, and 25. (OPTIONAL) Suspension Mode Display Lamps

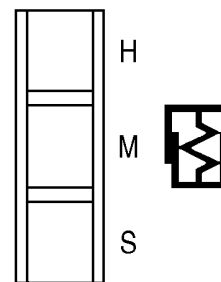

This monitor displays the type of suspension mode being used.

This **OPTIONAL** suspension feature automatically switches the damping characteristics of the suspension according to whether the truck is carrying a load, or whether the brake, steering, or dump controls are being operated.

Normally, the SOFT mode (25) is used when traveling empty, and MEDIUM (24) is used when traveling loaded. When using the service brakes or turning sharply, or when operating the dump control, the suspension mode is switched to HARD (23) to maintain the stability of the machine: front and rear, and left and right. This indicator is present in all instrument panels, but is inactive in trucks without this option.

EVERY 5000 HOUR SERVICE

Maintenance for every 250, 500, and 1000 hours should also be carried out at this time.

Truck Serial Number _____

Site Unit Number _____

Date: _____ Hour Meter _____

Name of Service Person _____

1. ENGINE DRIVELINE ADAPTER

Inspect driveline adapter splines, rubber dampers for cracks or separation on rubber surfaces, and bearings. Note any discrepancies and repair as required.

Refer to Shop Manual, Section C for repair procedures.

2. FRONT AND REAR DRIVESHAFTS

If the truck is equipped with driveshaft universal joints that DO NOT have grease fittings, inspect both front and rear driveshafts for binding, wear, vibration, or damage to the driveshaft assembly. If U-joint damage or roughness is noted, BOTH U-joints on a given shaft should be replaced. Refer to Shop Manual, Section F for replacement procedures.

3. FRONT SUSPENSIONS

Drain Front suspension oil. Inspect upper flange internal bearing. Replace worn parts.

Refill suspensions with clean oil and recharge with nitrogen. Refer to Shop Manual, Section H for instructions and WARNINGS when servicing suspensions.

4. FRONT WHEEL BEARINGS

Check front wheel bearing adjustment. Refer to Shop Manual, Section G, *Front Wheel Hub Bearing Adjustment*.

COMMENTS	CHECKED	INITIALS

PARKING BRAKE

PARKING BRAKE PAD

Inspection

PARKING BRAKE INSPECTION			
ITEM	NEW	LIMIT	REMEDY
Disc Face Runout	0.4 mm (0.016 in)	0.8 mm (0.032 in)	Replace
Disc Thickness	25 mm (0.99 in)	20 mm (0.79 in)	Replace
Pad (Includes Plate Thickness)	21.5 mm (0.847 in)	11.5 mm (0.45 in)	Replace

NOTE: The brake disc can be machined and reused until less than 20 mm (0.79 in.) thickness after machining.

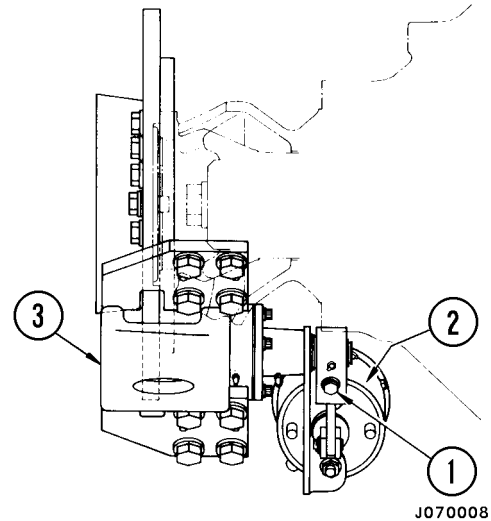

FIGURE 4-16. PARKING BRAKE ADJUSTMENT

1. Capscrew 3. Caliper
2. Spring Housing

PARKING BRAKE ADJUSTMENT

Testing

1. Stop the machine on level ground and apply the parking brake.
2. Raise the air pressure to 8.3 kg/cm² (118 psi).
3. Place the transmission shift lever in the D (F2) position.
4. Raise the engine speed gradually and measure the engine speed when the machine starts to move. The minimum engine speed is 1,720 RPM.

NOTE: When the machine starts to move, release the accelerator pedal, depress the brake pedal, and return transmission shift lever to N at the same time.

Adjusting

1. Turn capscrew (1, Figure 4-16) clockwise and bring both pads (1, Figure 4-17) into contact with disc (2).
2. Push in capscrew retainer (3, Figure 4-18) of slack adjuster (1) until the capscrew can turn, then turn capscrew (3) clockwise.
3. Turn capscrew (1, Figure 4-16) back from this position counterclockwise 360° ± 15° and measure clearance of caliper pad with feeler gauge (1, Figure 4-19).

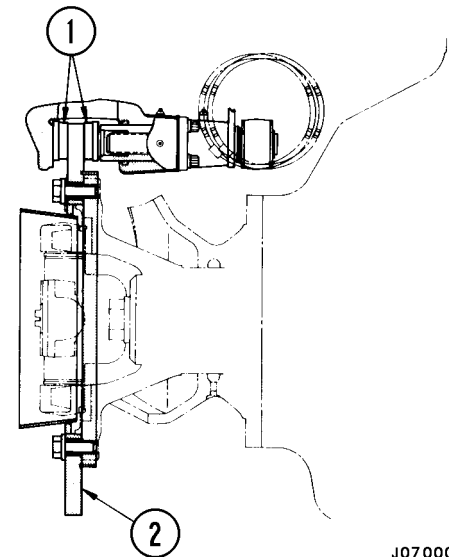

FIGURE 4-17. PARKING BRAKE ADJUSTMENT

1. Pads 2. Brake Disc

LIGHTS, SWITCHES, and COMPONENTS

On The Face Of The Payload Meter (Refer to Figure 6-1)

1. Display Panel

Digital display area for the data being recorded in memory. This will include items such as:

- Payload
- Date & Time
- Cycles
- Travel Distance
- Fault Codes and Warnings

2. Reception Pilot Lamp (Rx Busy)

This light will illuminate for 3 seconds when the system is powered up. It will then be lit whenever the computer is communicating.

3. Transmission Pilot Lamp (Tx Busy)

This light will illuminate for 3 seconds when the system is powered up. It will then be lit whenever the memory is being downloaded to a personal computer.

4. Memory Card Access Lamp (CARD Busy)

This light will illuminate for 3 seconds when the system is powered up. It will also be lit whenever the memory data is being downloaded to the memory card.

5. Mode Switch

This switch is used to select the mode or system that will allow a function to be performed. This may include:

- Various settings or corrections to the display
- Memory card downloading
- Clearing data
- Display of Abnormalities or Warnings
- Setting the speed limit
- Setting the date and time

6. Calibration/Clear Switch

Used to calibrate the machine when the conditions regulate this action. Also used with the TOTAL/SFT switch to clear total payload and overall number of cycles.

7. Total/Shift Switch

Used to display payload and overall number of cycles each time the load is dumped. Will display the error codes. This switch is also used with the CALIBRATION/CLEAR switch to clear total payload and overall number of cycles.

8. Light/Increment Switch

Used to change the digital increments or units for the various displays. Also used to adjust the brightness of the lights on the monitor display.

9. Memory Card

Used to receive data from the payload meter memory to this card which can then be used to transfer the data into a personal computer. This enables the memory to be downloaded and saved when a personal computer is not available.

10. Cover

Protective cover for the Memory Card. Do not open or place foreign objects in slot.

11. Diagnostic/Download Port

Connector port that is used for downloading the memory data to a personal computer.

INITIAL SETUP OF PAYLOAD METER

There are several things that must be checked and programmed when a payload meter is first installed.

1. Check the switch settings on the side of the meter.
2. Check the Operator Check Mode settings
3. Check the Service Check Mode settings
4. Calibrate the clean truck.

The next few pages show the steps required to perform these checks. Only after all of these steps have been performed can the payload meter be released for service.

Switch Settings

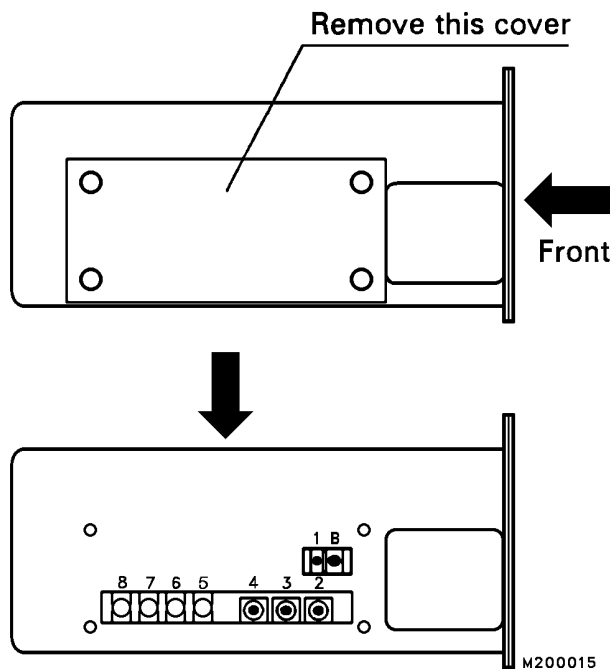

FIGURE 3-6.

There are nine switches located behind the panel on the left side of the payload meter. Figure 6-6 shows the switch numbers. The following switch positions should be confirmed before the meter is installed.

* Set switch 4 for the appropriate model.

Switch	Position
1	Initial Setup should be set to 1.00 - Gain Clockwise(-20%) CCW (+20%) Refer to "Gain Factor" for adjust guidelines
B	Do not Adjust - Buzzer Volume
2	7 - Speed Regulation 0=107%, 7=100%, F=92% The 930-2 should be set to '6'.
3	7 - Distance Regulation 0=107%, 7=100%, F=92% The 930-2 should be set to '6'.
4	4 - 685E 5 - 630E B - 730E C - 930E D - 530M E - 330M F - 830E
5	DOWN - Memory function (DOWN = Enable UP=Disable)
6	DOWN - Inclinator Use (DOWN = Enable UP=Disable)
7	DOWN = Short Tons, UP = Metric Tons
8	UP

⚠ IMPORTANT ⚠

930E-2 trucks are equipped with 53/80R63 series tires and require small changes to the switch settings of the PLM II™. The tires have a larger rolling radius than the PLM II™ assumes. This causes the PLM II™ to underestimate distances by 1%. The Speed Regulation and Distance Regulation switches should be switched to position 6. This is contrary to what the label may say.

Additionally, the payload gain on 930E-2 trucks also needs to be adjusted. The front suspensions are larger than the original 930E suspension, and therefore, data programmed into the payload meter is not completely accurate. The gain must be increased by 1%. There are two methods for changing this gain; changing the UP factor using the buttons on the front panel, or using the gain adjustment potentiometer on the side of the meter. The preferred method is using the potentiometer. Refer to "Adjusting the Gain".

Monitoring Input Signals

This procedure can be used to monitor the current input signals to the payload meter.

1. Press and hold the LIGHT/INC and MODE switches until "CHEC" is flashing.
2. Press and hold the CAL/CLR and TOTAL/SFT switches until "S.CHE" is flashing.
3. Press the CAL/CLR switch to cycle through the following information :

C1	Mechanical Trucks	C1:00 - Shift Selector in "N" C1:-- - Shift Selector not in "N"
C1	Electric Trucks	C1:00 - Brake Lock On C1:-- - Brake Lock Off
C2	Body Up	C2:00 - Body Down C2:-- - Body Up
C3	Engine Oil Pressure	C3:00 - Engine Run C3:-- - Engine Stopped
C4	Alternator R Terminal	C4:00 -Alternator Charging C4:-- - Alternator Stopped
C5	Analog 1 - Not Used	
C6	Analog 2 - Not Used	
C7	Digital 1 - Not Used	
C8	Digital 2 - Not Used	
C9	Speed	Vehicle Speed
C10	Travel Distance - under the current loaded or empty state	xx.xx Miles
C11	<u>Current Status</u> <i>Note: Sample values are shown.</i>	03:01 - Empty Stopped 01:02 - Empty Traveling 06:03 - Loading 02:04 - Loaded Traveling 04:05 - Loaded Stopped 05:06 - Dumping
C12a*	Time Empty Travel	S1:xx - Minutes*10
C12b	Time Empty Stopped	S2:xx - Minutes*10
C12c	Time Loaded Travel	S3:xx - Minutes*10
C12d	Time Loaded Stop	S4:xx - Minutes*10

* After 9.9 minutes, "S1:--" will be displayed.

4. Press the MODE switch once and "CHEC" will flash.
5. Press the MODE switch once and the meter will return to normal operation.

Service Check Mode

1. Press and hold the LIGHT/INC and MODE switches until "CHEC" is flashing.
2. Press and hold the LIGHT/INC switch until "ALL0" is flashing. "A.FUL" may also be displayed.
3. Press the LIGHT/INC switch to cycle through the following data. The sequence repeats.

Item and Description	Units
1. Current Time	Hours: Minutes
2. Pressure Front Left	Psi
3. Pressure Front Right	Psi
4. Pressure Rear Left	Psi
5. Pressure Rear Right	Psi
6. Front Weight	Tons
7. Rear Weight	Tons
8. Degree of Incline	±° Nose Up Positive
9. Incline Factor - Front Axle	
10. Incline Factor - Rear Axle	
11. Link Factor - Front Axle	
12. Link Factor - Rear Axle	
13. Calibration Weight	Tons
14. G _t Gain	
15. Current Load	Tons
16. Backup Battery Voltage	Volts

4. Press MODE once and "CHEC" will flash on the display.
5. Press MODE once and the meter will return to normal operation.

CLICK HERE TO **DOWNLOAD** THE COMPLETE MANUAL

- Thank you very much for reading the preview of the manual.
- You can download the complete manual from: www.heydownloads.com by clicking the link below



- Please note: If there is no response to CLICKING the link, please download this PDF first and then click on it.

CLICK HERE TO **DOWNLOAD** THE COMPLETE MANUAL