



115ZV-2



93116-00483
January 24, 2016

OPERATION & MAINTENANCE MANUAL

WHEEL LOADER

115ZV-2

93116-00483

NOTICE
READ AND UNDERSTAND THIS
MANUAL BEFORE OPERATING
AND SAVE THIS MANUAL ON
THE MACHINE

CLICK HERE TO **DOWNLOAD** THE COMPLETE MANUAL

- Thank you very much for reading the preview of the manual.
- You can download the complete manual from: www.heydownloads.com by clicking the link below



- Please note: If there is no response to CLICKING the link, please download this PDF first and then click on it.

CLICK HERE TO **DOWNLOAD** THE COMPLETE MANUAL

1.6
SAFETY
Safe Operation

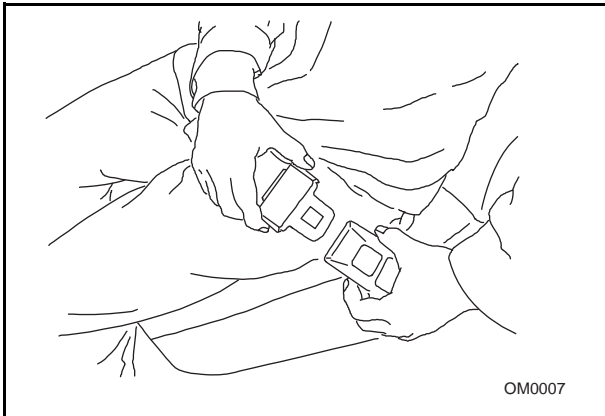

Adjust the seat, seat belt and steering column, mirrors, etc.

Properly fasten the seat belt.

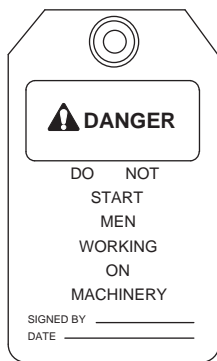

Do not start or operate the machine if a "DO NOT START" or a "DO NOT OPERATE" tag is on the key switch, steering wheel or controls.

Do not operate the engine where there are or can be combustible vapors. These vapors can be drawn through the air intake system and cause engine overspeeding, which can result in a fire, and explosion.

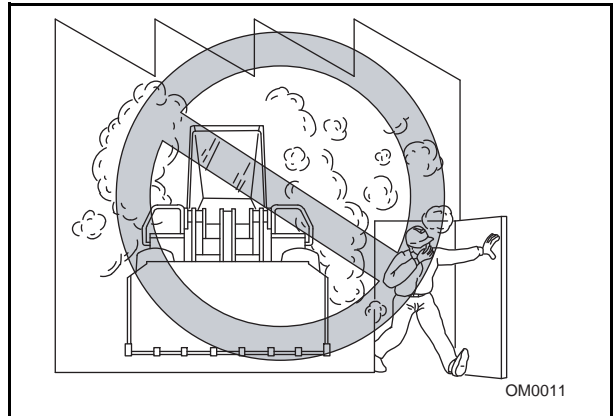

Do not start to work in an enclosed area if adequate ventilation is not provided. Fumes could build up during operation that could cause drowsiness, injury, or death.

Blow the horn for a few seconds just before starting the engine to alert bystanders.

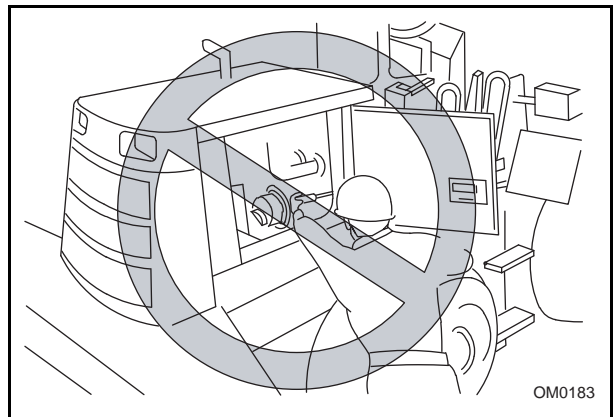

Start the machine only from in the operator's seat.

- Do not reach through the window to start.
- Do not stand on the ground and start.
- Never attempt to start by shorting across the starter motor terminals since this can bypass the neutral start safety device.

If jumper cables are required to start the engine, follow the correct procedure in "Booster Batteries / Jumper Cables" page 2.102.

1.16
SAFETY
Safe Maintenance

Do not operate the engine where there are or can be combustible vapors. These vapors can be drawn through the air intake system and cause engine overspeeding, which can result in a fire, and explosion.

To prevent ignition, use the luminaire when checking oil, cooling water, fuel and battery electrolyte level.

Move ignitable things to a safe place when grinding welding or gas cutting.

Charge a battery at well ventilated place and keep fire away from it during charging.

Other Maintenance Safety Concerns

Periodically check the ROPS bolts (if equipped) to be sure they are in place and tight.

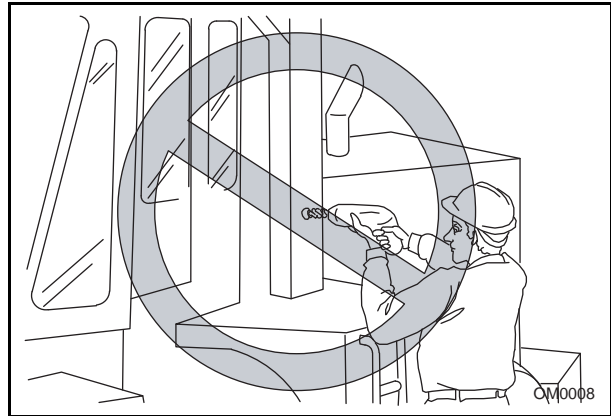

Never weld, drill or in any way modify the ROPS without approval from the manufacturer.

Stop the engine before opening the engine access panel.

Contact with belts, pulleys, or other moving parts will cause injuries.

During servicing, inspect the wiring harnesses, connections and wires and replace any that may be chafed, or tighten any that may be loose.

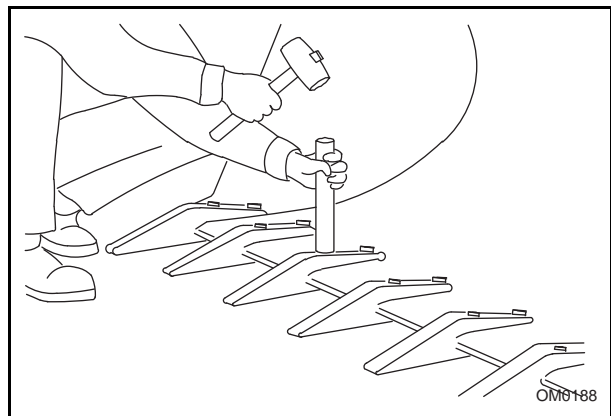

Keep the area clear of bystanders and wear eye protection when striking pins, teeth, or cutting edges during removal or installation. Metal pieces can fly off and cause injury. Use a brass drift or a dead blow hammer as required by the job.

Keep the area clear of bystanders and wear proper eye protection and protective clothing when grinding or welding.

12.

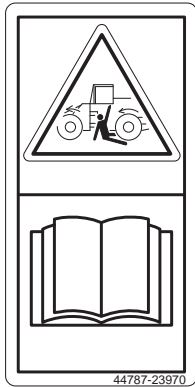

⚠ WARNING

Machine movement, if engine starts in gear, could result in death or serious injury.

- Do not start engine by shorting across starter terminals.
- Do not start engine while standing on ground.

Make sure to start engine only from operator's seat with transmission in neutral and parking brake applied.

13.

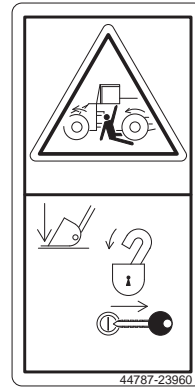

⚠ WARNING

Accidental movement of machine could result in death or serious injury.

Before checking transmission oil:

- Park on level ground.
- Lower attachment to ground.
- Place transmission in neutral.
- Set parking brake.
- Tag "Do Not Operate."

14.

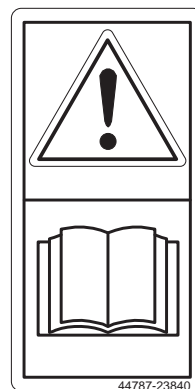

⚠ WARNING

Improper operation or maintenance could result in death or serious injury.

Read, understand, and follow Operation & Maintenance Manual before operating or servicing machine.

Follow all safety signs and instructions in Operation & Maintenance Manual or on machine.

6. Auxiliary Attachment Control Lever (option)

Auxiliary attachment control lever is used to control the auxiliary attachment such as log clamps, multi-purpose buckets, etc.

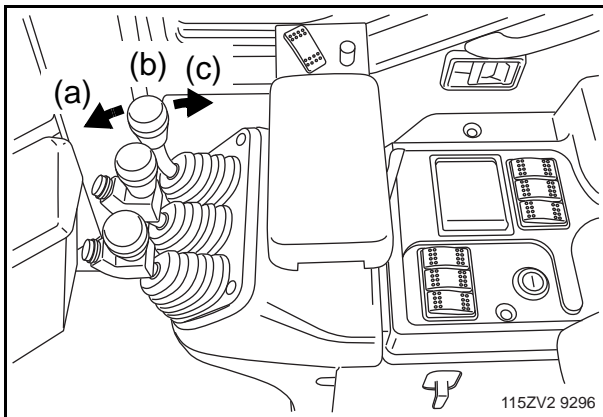

- (a) Normally this position will close the attachment.
- (b) This center position will cause the attachment to stop and remain in that position.
- (c) Normally this position will open the attachment.

In case that the auxiliary attachment does not stop moving even when the auxiliary attachment control lever is in the HOLD position, turn the starter switch to the "OFF" position to stop the engine.

NOTE

If equipped with attachments other than the standard bucket, consult the attachment supplier for specific instructions.

IMPORTANT

KCM will not accept any liability for any attachments and spare parts not approved by KCM.

7. Wrist Rest

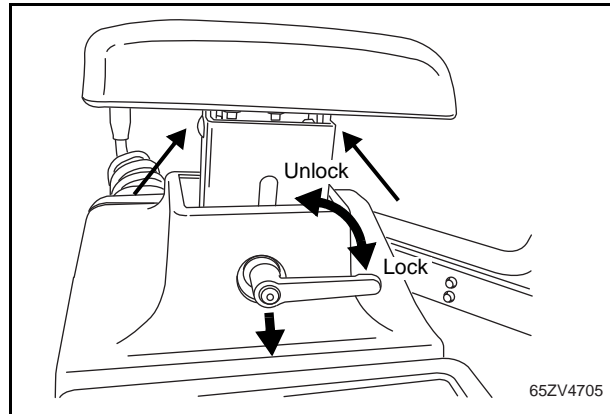

Wrist rest is used to put on the wrist or arm while operating the bucket/boom control levers.

(High/Low)

Pull the lever out and turn, bringing back to the original position, to adjust the height.

(Front/Rear)

Loosen the screws to adjust the position.

10. Downshift Button

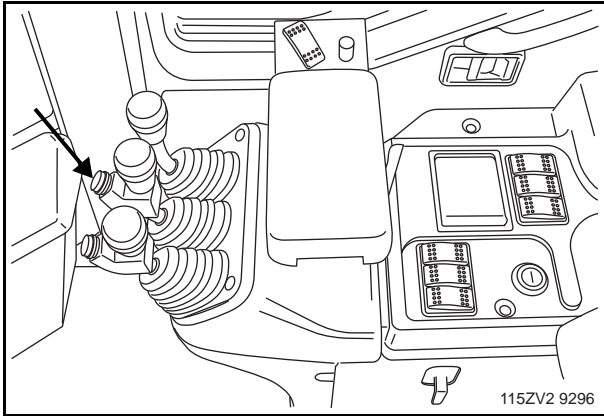

Downshift button is used to quickly shift down the transmission from 2nd gear to 1st gear without moving the transmission shift lever.

- When operating the machine in 2nd speed with the shift lever in [2] or [A] position, the transmission will shift down to 1st gear by pressing downshift button.
- Pressing downshift button again or moving the transmission shift lever to the opposite direction releases the 1st gear setting to return to 2nd gear.

11. Four-Way Flasher Switch (option)

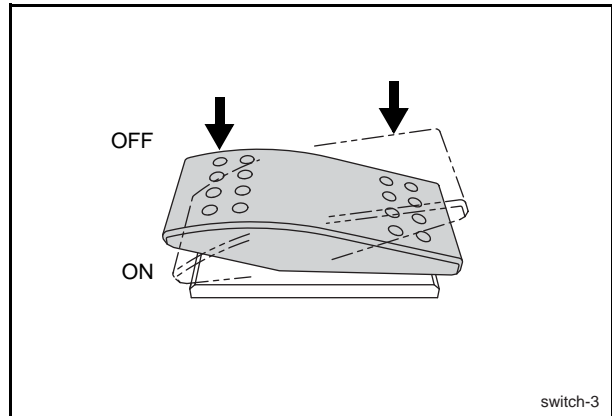
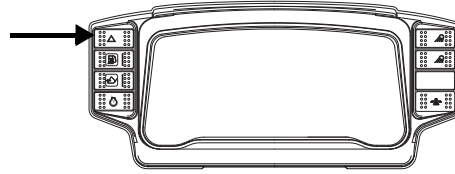

The two front and two rear turn signal lights will flash when four-way flasher switch is ON.

This is used in emergency, when parking on the road, etc. to warn other vehicles.

Indicators

(11C5-0151~0250)

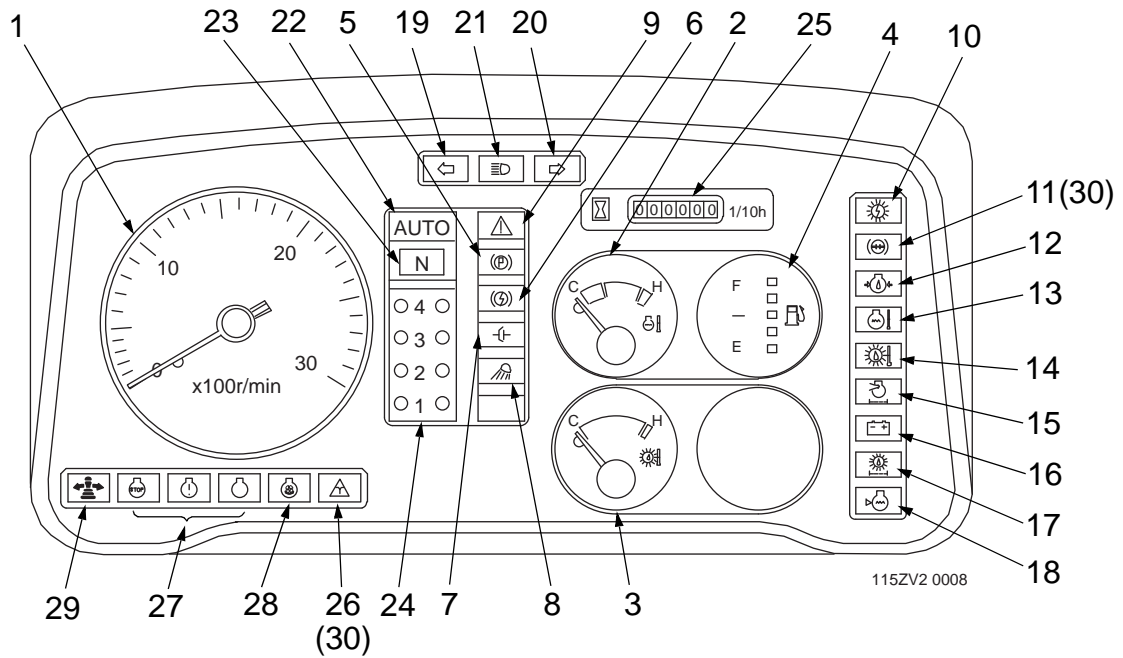

(11C5-0251~)

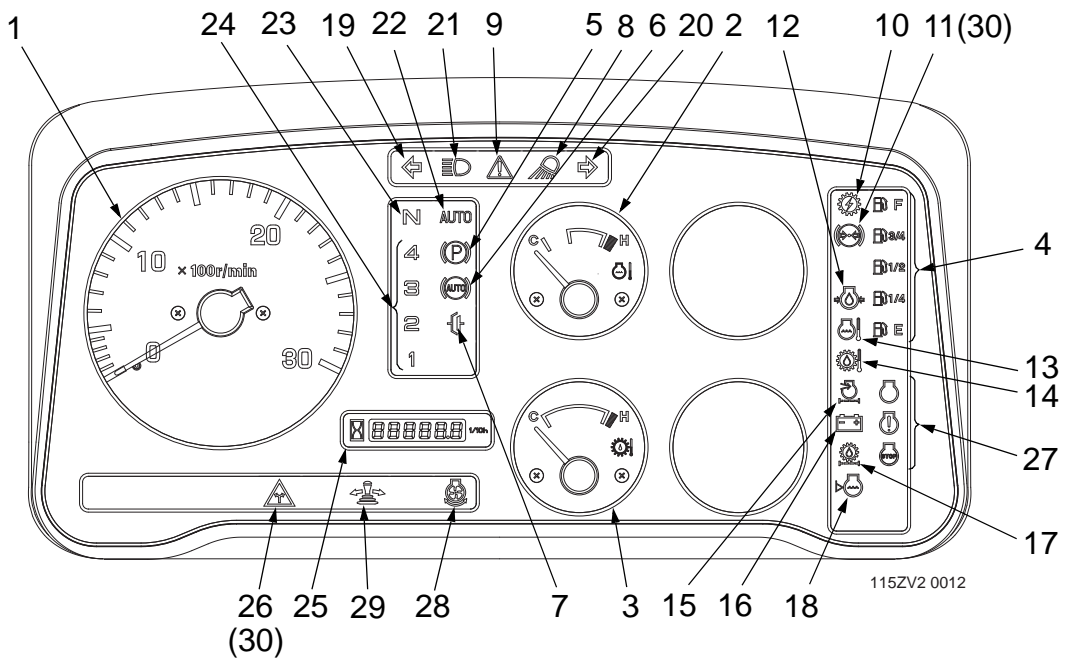

MODM

(Machine Operation Diagnostic Module)

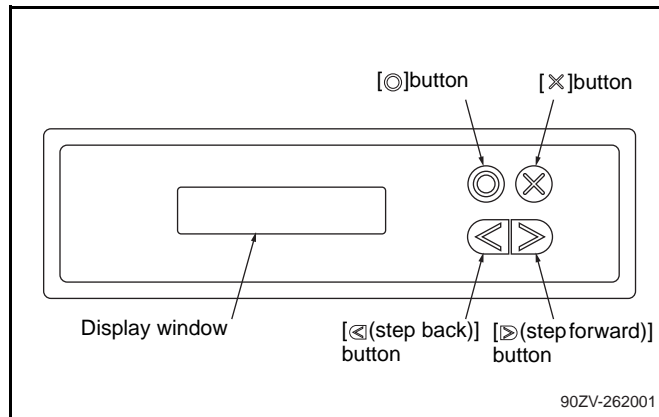

MODM function

The MODM has the following functions:

- Information monitor
- Displays outside air temperature, machine speed and engine speed, engine coolant temperature, transmission oil temperature, hydraulic oil temperature and miles driven etc.
- Replacement monitor
 Allows check of the replacement time for the parts and oil periodically replaced, allows setting of the replacement interval, and displays the replacement pop-ups.
- Error log monitor
 Allows check of previous errors, and displays active errors.
- Input/Output monitor
- Parameter setting monitor
 Allows check and change of the parameter setting.
- Specification setting monitor
 Allows check and change of the specification setting.

Monitor Changeover

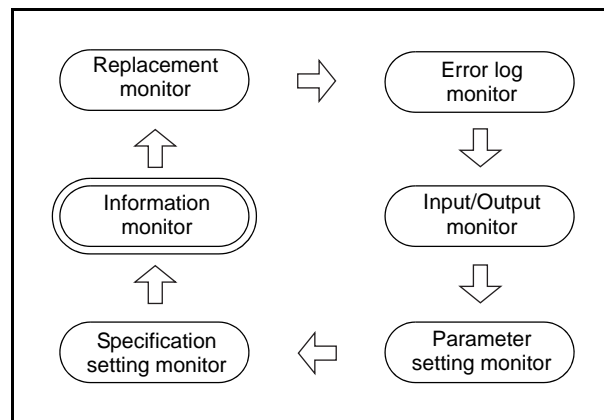

Change over the monitor using the following procedure:

When the starter switch is ON, the information monitor is first displayed on initial monitor.

Press the [◀] (step back) button and [▶] (step forward) button at the same time to change over the monitor mode in sequence "Information monitor → Replacement monitor → Error log monitor → Input/Output monitor → Parameter setting monitor → Specification setting monitor → Information monitor".

However the monitor mode can not be changed in reverse such as "Information monitor → Specification setting monitor → Parameter setting monitor"

The display will not be changed to the next monitor when you hold the buttons.

Seat

Seat Adjustment

(KAB811)

Adjust the seat for comfort and so that the pedals may be pushed fully down when the operator's back is fully back.

⚠ WARNING

Unexpected movement of seat could result in death or serious injury.

Stop machine before adjusting seat position.

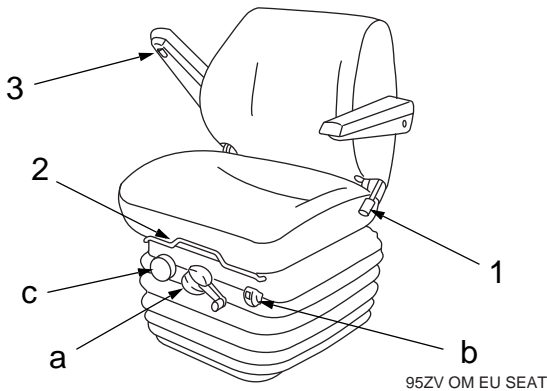

Reclining

Rotate control handle (1) forward and hold, select backrest angle, release control handle.

Forward / Backward

Lift lever (2) up and hold, slide seat to desired position, release handle.

Armrests

Rotate control knob (3) to select desired angle. Pivot up and parallel with backrest when not in use.

Combined Height and Weight Adjuster

1. Sit on the seat.
2. Turn handle (a) to adjust seat height.

Clockwise to raise seat.

Anti-Clockwise to lower seat.

3. Check ride indicator (b) shows green.

If red, readjust seat height.

Within the green band of the ride indicator there is 75 mm of height adjustment for any driver.

NOTE



The seat is designed so that it is unnecessary to make any adjustment for the driver weight.

Up-Stop Height Adjustment Control

To adjust the up-stop height, rotate hand wheel (c) clockwise to raise the seat unseated, rotate it counter-clockwise to lower the seat unseated.

OPERATOR'S AREA

Radio - AM / FM Cassette (24Volt Type) (option) (~December, 2009)

Symbol	Name of part	Function	Operation method	Description	Remarks
15	2 PRO Preset 2 Program button	In radio mode: Recalling and storing preset memories	PUSH	Push the button for less 2 sec. to recall preset stations. Pushing the button for 2 sec. or longer will generate a beep sound and the currently tuned station will be stored.	
		In cassette tape mode: Program	PUSH	Push the button to program the tape. (Switching forward or reverse modes.) Pushing the button in FF, REW (APC) mode will play the cassette tape.	
		In CD mode: DISC UP	PUSH	Push the button to go to the next disc. (Recalling the next disc.)	
16	3  FF Preset 3 FF button	In radio mode: Recalling and storing preset memories	PUSH	Push the button for less 2 sec. to recall preset stations. Pushing the button for 2 sec. or longer will generate a beep sound and the currently tuned station will be stored.	
		In cassette tape mode: FF	PUSH	Push the button to wind forward the cassette tape quickly.	
		In CD mode: DISC UP	PUSH	Push the button to go to the next disc. (Recalling the next disc.)	
17	4  APC Preset 4 APC button	In radio mode: Recalling and storing preset memories	PUSH	Push the button for less 2 sec. to recall preset stations. Pushing the button for 2 sec. or longer will generate a beep sound and will store the currently tuned station.	
		In cassette tape mode: APC REW	PUSH	Push the button to search for the beginning of the currently-played music track. Pushing the button again in APC REW mode will search for the beginning of the previous music. (Every time it is pushed after that, the number of music tracks to search for will be increased by 1.)	
		In CD mode: TRACK DOWN REVIEW	PUSH	Push the button for less 2 sec. to search for the beginning of the currently-played track. (If the button is pushed at the beginning of the music track, the beginning of the previous music track will be searched for.) Push the button for 2 sec. or longer to rewind the CD fast.)	No beep sounds

Grease Gun Holder

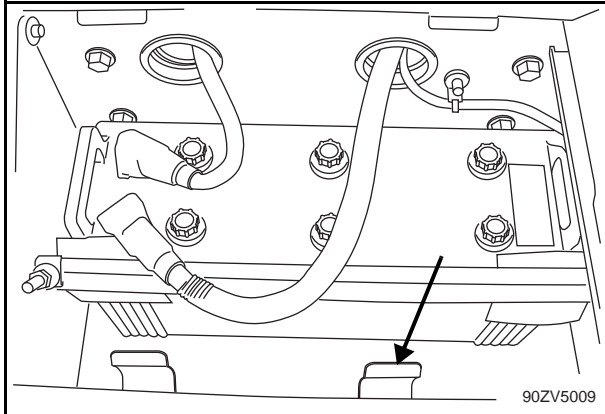

Grease gun holder is provided in the left side battery box. It is used for keeping the grease gun on the machine when not in use.

CLICK HERE TO **DOWNLOAD** THE COMPLETE MANUAL

- Thank you very much for reading the preview of the manual.
- You can download the complete manual from: www.heydownloads.com by clicking the link below



- Please note: If there is no response to CLICKING the link, please download this PDF first and then click on it.

CLICK HERE TO **DOWNLOAD** THE COMPLETE MANUAL

2.76

OPERATION

Check before Operation

Check Monitor Panel Operation

1. Turn the starter switch to the "ON" position.
2. All warning lamps (red) should come on for about three seconds. Refer to "Indicators" page 2.26.
3. Rotate and move the transmission shift lever to each position, pull the high-low beam lever, and operate the rear working light switch and declutch ON/OFF switch.
4. The transmission status monitor lamps (green) and the indicator lamps (green or blue) should come on respectively.
5. If any lamps do not light up, replace the bulbs. Refer to "Indicators" page 2.26.

Check Control Levers

- Make sure the boom and tilt control levers are in the "HOLD" position.

Check Transmission Shift Lever

- Make sure the transmission shift lever is in the neutral position.

Operating the Machine

WARNING

Stopping engine while machine is moving will cause loss of steering control which could cause serious injury or death.

Do not stop engine while machine is moving.

WARNING

Moving machine in congested areas could result in death or serious injury.

Be sure area is clear of personnel and obstructions.

IMPORTANT

Operating machine on a grade may cause lack of lubrication resulting in severe engine or components damage.

Do not operate machine on a grade over 30°.

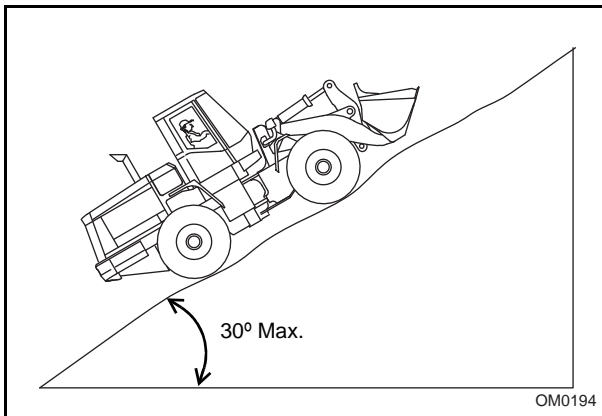

Starting the Machine

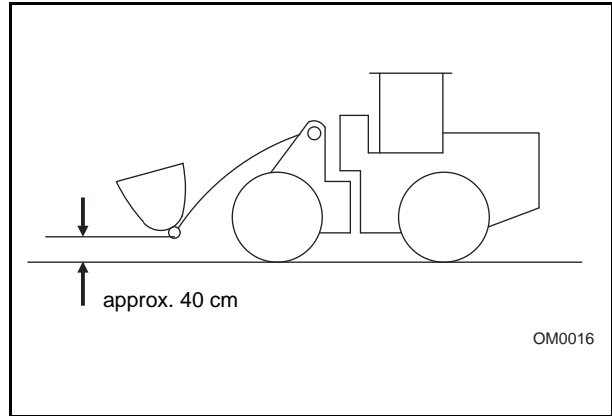

1. Raise the bucket to the carry position approximately 40 cm above the ground.
2. Step on the brake pedal.
3. Push the parking brake switch to release the parking brake.
4. Turn the transmission shift lever to the desired travel speed mode and then shift to the desired direction.

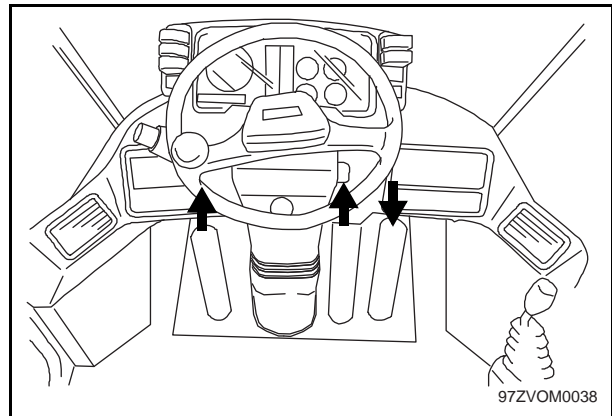

5. Release the brake pedal then step on the accelerator pedal to drive the machine.

WARNING

When parking brake is released, machine could roll on a grade unexpectedly causing injury or death.

When starting machine on a grade, firmly step on brake pedal before releasing parking brake.

2.96
OPERATION
Operating Techniques

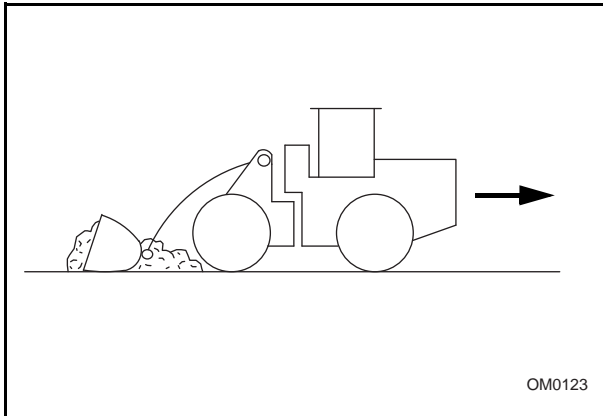

4. To get smoother surface, put some material in the bucket, place the bucket parallel to the ground, run the machine backward with the boom control lever in the "Float" position.

IMPORTANT

Pushing material with dumped bucket may cause severe damage to linkages.

Be sure to run machine backward when leveling ground.

Carrying

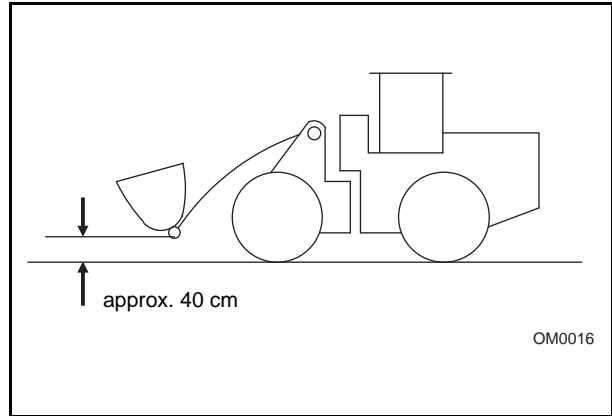

1. Fully roll back the loaded bucket before carrying to prevent spillage.
2. Keep the bucket approximately 40 cm above the ground when carrying.

IMPORTANT

When carrying material over 450 m at high speed, tire overheating may occur.

Follow tire manufacturer's instructions for tire inflation on this type of application.

2.106
SPECIAL PROCEDURES
Transportation

10. Determine the route for transporting the machine by taking into account the width, height and weight of the machine and truck.

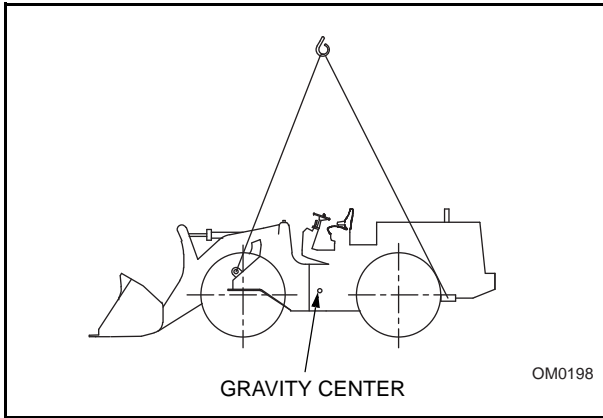

11. In the case that it is necessary to lift the machine, sling the machine at 4 fixing points (red painted) provided on the machine as shown.

Weight: 47 ton

3.4
 MAINTENANCE
 Inspection and Maintenance Table

Inspection and Maintenance Table

Check and/or carry out the maintenance at intervals of the specified operating hours below or the calendar date, whichever comes first.

IMPORTANT

Severe applications require more frequent maintenance.
 Severe conditions include heavy dust, extremely abrasive material, caustic chemicals, extremely wet conditions or abnormally hot or cold ambient temperatures.

△ : First time replacement or cleaning only

Section	Item for check	Operating hours						When Required	Page
		10	50	250	500	1000	2000		
Engine	Check Engine Oil Level	○							2.68
	Check Engine Coolant Level	○							2.70
	Drain Water and Sediment from Fuel Pre-filter	○							2.71
	Check Drive Belt	○							2.74
	Check Air Intake System	○							2.74
	Check Cooling Fan	○							2.75
	Check Warning Lamps	○							2.81
	Check Fuel Level	○							2.82
	Check Exhaust Gas	○							2.85
	Drain Water and Sediment from Fuel Tank		○						3.23
	Replace Fuel Filter Cartridge			○					3.27
	Replace DCA4 Coolant Filter Cartridge				○				3.40
	Clean Crankcase Breather Tube			○					3.29
	Adjust Belt Tension			○					3.29
	Replace Engine Oil and Oil Filter Cartridge				○				3.37
	Check and Adjust Injection Timing					○			3.47
	Check Engine Compression Pressure					○			3.47
	Check Injection Pressure					○			3.47
	Replace Fuel Tank Breather					○			3.48
	Clean Fuel Tank						○		3.56
	Check Vibration Damper						○		3.56
	Clean Crankcase Breather						○		3.61
	Clean or Replace Air Cleaner Element							○	3.10
	Clean Radiator / Air cooler / Hydraulic oil cooler / Fuel cooler Fins							○	3.11
	Replace Ether Cylinder							○	3.16
	Clean or Replace Air Cleaner Element		After six cleanings or once a year ○						3.10
Replace Coolant		Every 2 years or 3000 hours ○						3.14	

Clean Air Conditioner Condenser

If mud, insects, or other debris are stuck to the air conditioner condenser, air flow through the condenser will be reduced causing decreased cooling ability.

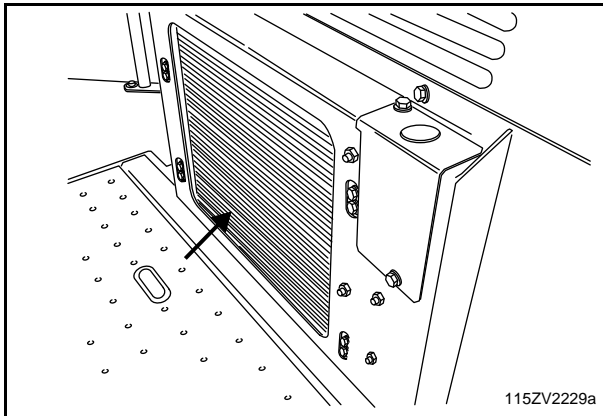

1. Park the machine on level ground, apply the parking brake, lower the attachment to the ground, and stop the engine.
2. Inspect the condenser and replace it if any damage is found.
3. Clean its fins using compressed air, a pressure washer or a soft brush. Be sure the air pressure is below 196 kPa. If a pressure washer is used, keep the nozzle about 50 cm away from the fins to prevent fin damage.
4. If water is used for the cleaning, cover the electrical parts of the engine and the electric condenser fan with plastic sheets. Remove the plastic sheets after cleaning.

IMPORTANT

An excessively high air or water discharge pressure can damage the condenser fins.

- When used for cleaning purposes, the pressure of compressed air should be at 196 kPa or less.
- When cleaning with water, apply the water jet perpendicular to the core.

Replace Coolant

- Since the Anti-Freeze "Long Life Coolant" (LLC) is originally used for the machine shipped from the factory, it is not necessary to replace the coolant for the first two years.
- If the cooling system conditioner (from a local supplier) is used at the time of last replacement, follow its instructions or contact your nearest authorized dealer for the replacement interval.

CAUTION

Pressurized radiator tank is used for this machine.

Spray of hot coolant may cause burns.

Stop engine and allow radiator and coolant to cool completely, then open cap slowly to relieve pressure.

1. Park the machine on level ground, apply the parking brake, lower the attachment to the ground, and stop the engine.
2. Inspect all coolant hoses.

Replace any that are cracked, swollen, or brittle.

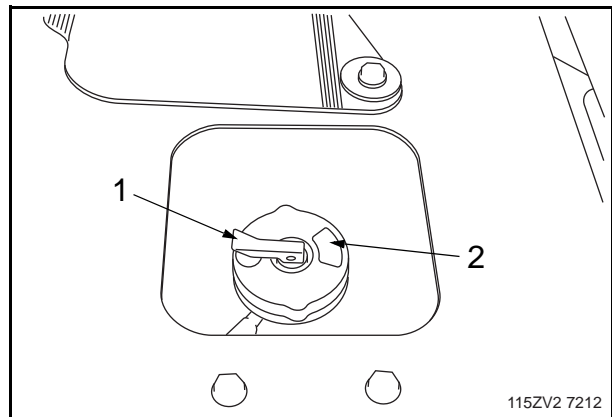

3. Lift lever (1) to release any remaining pressure.
4. Remove cap (2) slowly.

3.24

MAINTENANCE

Every 50 Hours or 1 Week

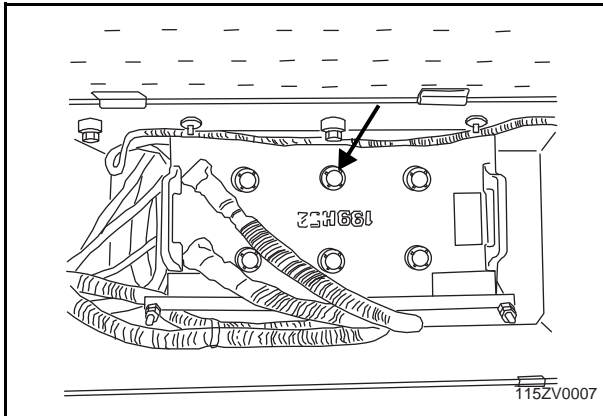

1. Park the machine on level ground, apply the parking brake, lower the attachment to the ground, and stop the engine.
2. Clean the battery surface with a clean cloth or soft brush.

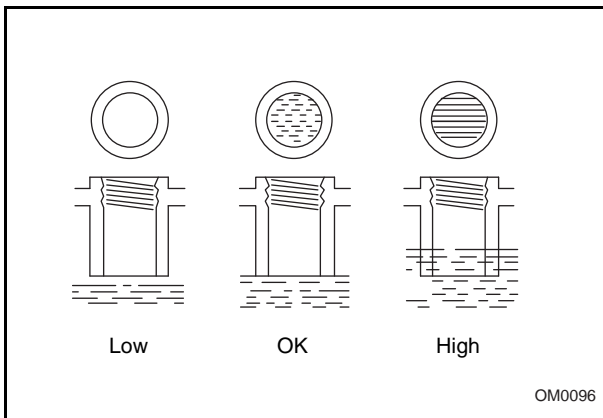

3. Check the battery electrolyte level in each cell. Electrolyte should cover the cell plates.
4. If the level is low, add distilled water until it reaches the bottom of the filler neck.

NOTE

If a maintenance free battery is used, step 3 and 4 of this inspection and maintenance is not required.

Check Tire Air Pressure

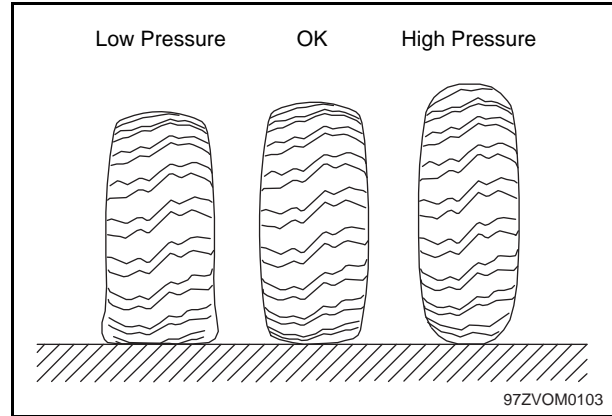

Tire performance and its life depend greatly on the tire air pressure.

- Low air pressure causes excessive deflection, heat, and accelerated wear.
- High air pressure cause reduced traction, slippage, and possible blow outs.

It is important to keep the tire pressure at the recommended level.

Special applications, such as long load and carry operations, may require different pressures. Consult the tire manufacturer.

⚠ WARNING

Overheated tire may explode causing serious injury or death.

If overheated tire is suspected, do not approach tire to distance of less than 15 m.

Stay away until tire and rim cool down.

1. Before starting work and while the tires are still cool, measure the tire air pressure with the tire pressure gauge.

3.34
MAINTENANCE
Every 250 Hours or 1 Month

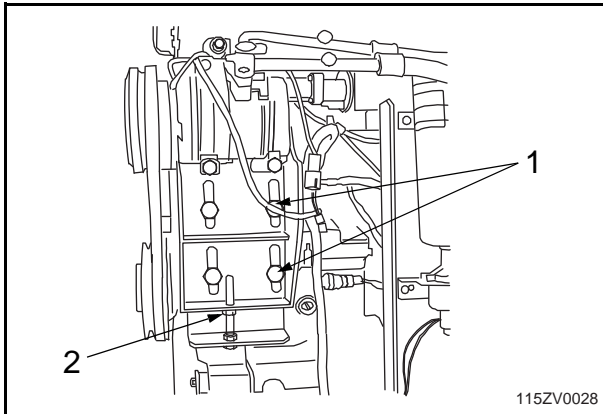

6. If the belt is too loose or tight, adjust the tension by loosening lock nuts (1) and turning adjusting nut (2) on the compressor bracket.

Clean Air Conditioner Filter Element

Outer filter cleaning

1. Park the machine on level ground, apply the parking brake, lower the attachment to the ground.
2. Turn the air conditioner "OFF" and stop the engine.

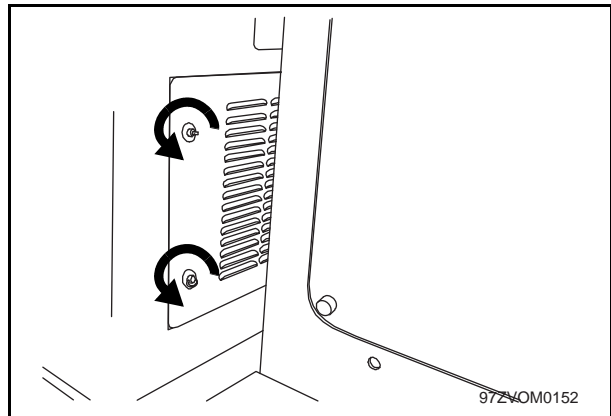

3. The cover for the outer filter is located at the left rear side of the cab.

Turn the rings counterclockwise and then remove the cover.

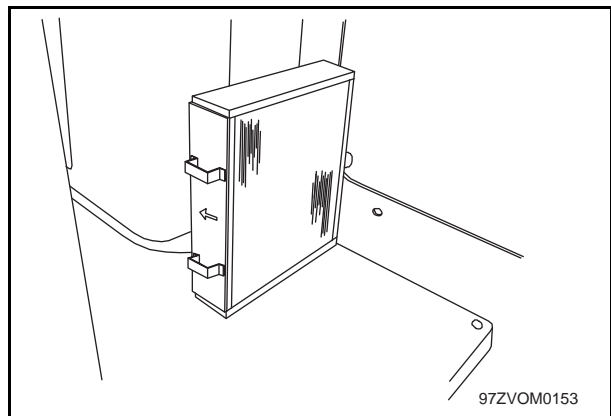

4. Remove the outer filter from the cab.
5. Remove dust with compressed air. Use air pressure below 196 kPa.
6. To remove more stubborn debris, wash the filter with clean water. Leave them for five to seven days for dry in the shade.

3.44

MAINTENANCE

Every 1000 Hours or 6 Months

6. Remove flange (3) together with the pipe and suction strainer.

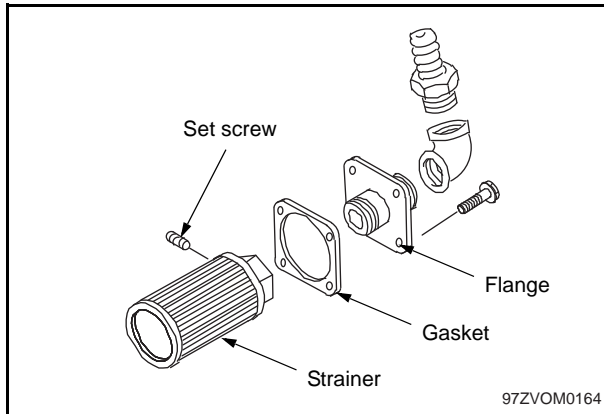

7. Remove the set screw using a 2.5 mm hex (allen) wrench from the strainer.
8. Remove the suction strainer from the flange, brush off any debris and clean with solvent.

Reassemble the strainer and flange assembly.

It is normal for a few fine particles to be on the strainer. Large pieces or a large quantity of particles indicates a problem.

Contact a authorized dealer if you find excessive debris.

9. Reinstall the drain plug and the strainer with a new gasket.
10. Tighten four bolts (2) to 53.0 N-m.
11. Fill with the specified oil.

Refer to "Recommended Lubricants" page 3.62.

12. Idle the engine and check for leaks.

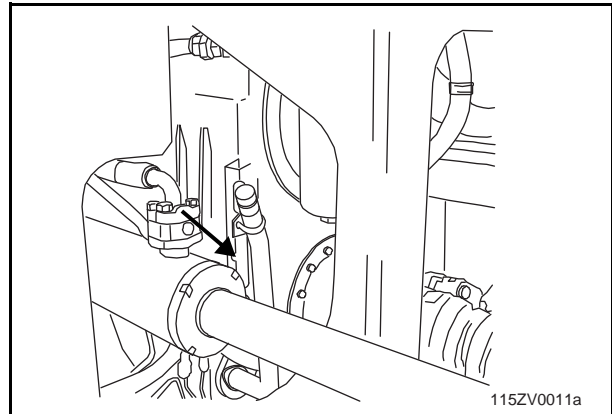

13. Check the oil level with the sight gauge. Add the specified oil if necessary to maintain the proper oil level.

Refer to "Check Transmission Oil Level" page 2.82 and "Recommended Lubricants" page 3.62.

14. After replacing the filter and/or oil, reset the interval timer for the replacement. Go to the timer reset screen of the MODM, and reset the corresponding replacement interval.

Refer to "Replacement Monitor" page 2.41.

3.54

MAINTENANCE

Every 2000 Hours or 1 Year

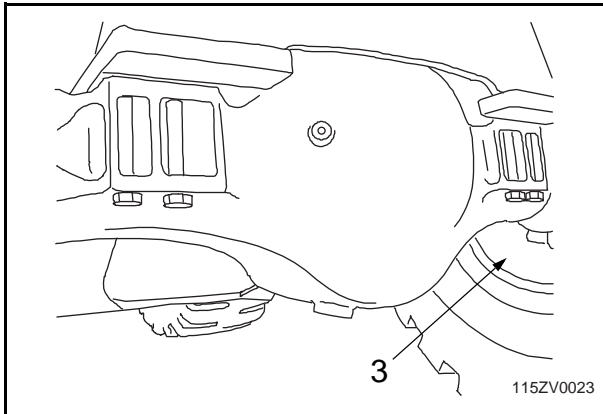

11. After replacing the filter and/or oil, reset the interval timer for the replacement. Go to the timer reset screen of the MODM, and reset the corresponding replacement interval.

Refer to "Replacement Monitor" page 2.41.

4. Remove level plug (2) and drain plug (3) from the planetary gear housing, using a 12 mm hex (Allen) wrench.

Some fine metallic powder will normally stick to magnet plug (2).

Simply wipe it off.

5. Drain the oil (about 32.5 liters) into a suitable container.
6. Dispose of the waste oil properly.

CAUTION

Used oil may cause skin disease.

Do not allow used oil to remain on skin for prolonged periods of time.

Clean skin thoroughly with soap and water.

7. Install and tighten the drain plug.
8. Refill the recommended oil through level plug hole (2) until the oil comes out from the hole.

Refer to "Recommended Lubricants" page 3.62.
9. Install and tighten the level plug.
10. Repeat these steps for all four planetaries.

Coolant Specification

The machine is originally filled with Long Life Coolant (non-Amin type ethylene glycol) which need not be replaced for the first two years or 3000 hours.

Do not use Amin type Long Life Coolant in cooling system. It may cause a corrosion against radiator or heater core.

If standard antifreeze (not Long Life Coolant) is used for the replacement, it should be replaced every six months.

Recommended Mixture of Antifreeze

Expected Minimum Ambient Temperature		-35°C	-30°C	-25°C	-20°C	-15°C
Pure Water	(liter)	72.8	80.6	88.3	96.1	103.8
Antifreeze	(liter)	82.2	74.4	66.7	58.9	51.2
Mixture Ratio (%)		53	48	43	38	33

- Too much antifreeze in the coolant mixture may cause engine overheating.

Keep 33 % antifreeze mixture (same as the mixture for a minimum ambient temperature of -15 °C) if the engine overheats in a high ambient temperature.

- Do not use hard water or water with high levels of calcium and magnesium ions as the coolant water.

IMPORTANT

Do not mix different brands of antifreeze because they each contain special additives. Careless mixing often diminishes the effect of these additives and causes packing damage or water leakage.

3.74
TROUBLESHOOTING

Error log monitor failure code (Output side)

Code	Failure	Detection condition
CN512	F solenoid valve malfunction	F solenoid valve is short-circuited or disconnected
CN514	R solenoid valve malfunction	R solenoid valve is short-circuited or disconnected
CN516	1st solenoid valve malfunction	1st solenoid valve is short-circuited or disconnected
CN518	2nd solenoid valve malfunction	2nd solenoid valve is short-circuited or disconnected
CN521	3rd solenoid valve malfunction	3rd solenoid valve is short-circuited or disconnected
CN524	4th solenoid valve malfunction	4th solenoid valve is short-circuited or disconnected
CN526	D solenoid valve malfunction	D solenoid valve is short-circuited or disconnected
CN528	H solenoid valve malfunction	H solenoid valve is short-circuited or disconnected
CN531	LU solenoid valve malfunction	LU solenoid valve is short-circuited or disconnected
CN534	Auto brake solenoid valve malfunction	Auto brake solenoid valve is short-circuited or disconnected
CN536	Speed change control solenoid valve malfunction (1)	Speed change control solenoid valve is short-circuited
CN537	Speed change control solenoid valve malfunction (2)	Speed change control solenoid valve is disconnected
CN621	S/S solenoid valve R malfunction (1)	S/S solenoid valve R is short-circuited
CN622	S/S solenoid valve R malfunction (2)	S/S solenoid valve R is disconnected
CN623	S/S solenoid valve L malfunction (1)	S/S solenoid valve L is short-circuited
CN624	S/S solenoid valve L malfunction (2)	S/S solenoid valve L is disconnected
CN631	Pressure increase solenoid valve malfunction	Pressure increase solenoid valve is short-circuited or disconnected
CN641	Ride control solenoid valve malfunction	Ride control solenoid valve is short-circuited or disconnected
CN681	Efficient loading system selection solenoid valve malfunction	Efficient loading system selection solenoid valve is short-circuited or disconnected
CN693	Lower kickout relay malfunction (1)	Lower kickout relay (coil) is short-circuited
CN694	Lower kickout relay malfunction (2)	Lower kickout relay (coil) is disconnected
CN712	Cooling fan solenoid valve malfunction (1)	Cooling fan solenoid valve is short-circuited
CN713	Cooling fan solenoid valve malfunction (2)	Cooling fan solenoid valve is disconnected
CN721	Hour meter drive malfunction	Hour meter drive is short-circuited

Fuel level display table

Input					Output				
1/8	1/4	1/2	3/4	F	E	1/4	1/2	3/4	F
x	x	x	x	x	⊙	—	—	—	—
○	x	x	x	x	●	—	—	—	—
○	○	x	x	x	—	●	—	—	—
○	○	○	x	x	—	—	●	—	—
○	○	○	○	x	—	—	—	●	—
○	○	○	○	○	—	—	—	—	●
Other than above					—	—	—	—	—

○: No input signal given ●: Lamp on ⊙: Lamp flashing
x: Input signal given —: Lamp off

CLICK HERE TO **DOWNLOAD** THE COMPLETE MANUAL

- Thank you very much for reading the preview of the manual.
- You can download the complete manual from: www.heydownloads.com by clicking the link below



- Please note: If there is no response to CLICKING the link, please download this PDF first and then click on it.

CLICK HERE TO **DOWNLOAD** THE COMPLETE MANUAL