

Instruction manual

ICC224CHF-1EN4.pdf
Operation & Maintenance

Vibratory roller
CC224CHF

Engine
Cummins QSB 3.3

Serial number
***284S00006* -**
10000312x0A000001 -



Translation of original instructions

CLICK HERE TO **DOWNLOAD** THE COMPLETE MANUAL

- Thank you very much for reading the preview of the manual.
- You can download the complete manual from: www.heydownloads.com by clicking the link below



- Please note: If there is no response to CLICKING the link, please download this PDF first and then click on it.

CLICK HERE TO **DOWNLOAD** THE COMPLETE MANUAL

Introduction

The machine

Dynapac CC224CHF is a self-propelled vibratory combination roller in 8 metric tonnes class featuring 1500 mm (59in) wide steel drum front and four smooth rubber tires at rear. The machine is equipped with drive, brakes, vibration and timer for water sprinkler on the drum.

The rubber tires are driven and braked in pairs and also equipped with a sprinkler system for the use of fluid from a separate emulsion tank or from the central water tank.

Scrapers and cocoa mats are always mounted on the rubber tires and on the drum scrapers are mounted and cocoa mats are optional.

A variety of different engine power settings, operator platforms, control possibilities and options makes the machine available in a lot of different configurations.

Intended use

CC224CHF is mainly designed to be used for thin and thick asphalt layers with regards to dual vibration amplitudes that are optimized for this purpose. It is also possible to compact granular soil material, such as sand and gravel.

Warning symbols



WARNING ! Marks a danger or a hazardous procedure that can result in life threatening or serious injury if the warning is ignored.



CAUTION ! Marks a danger or hazardous procedure that can result in damage to the machine or property if the warning is ignored.

Safety information



It is recommended to at least train operators in handling and daily maintenance of the machine in accordance with the instruction manual. Passengers are not allowed on the machine, and you must sit in the seat when operating the machine.

Special instructions

Standard lubricants and other recommended oils and fluids

Before leaving the factory, the systems and components are filled with the oils and fluids specified in the lubricant specification. These are suitable for ambient temperatures in the range -15°C to +40°C (5°F - 104°F).



The maximum temperature for biological hydraulic fluid is +35°C (95°F).

Higher ambient temperatures, above +40°C (104°F)

For operation of the machine at higher ambient temperatures, however maximum +50°C (122°F), the following recommendations apply:

The diesel engine can be run at this temperature using normal oil. However, the following fluids must be used for other components:

Hydraulic system - mineral oil Shell Tellus T100 or similar.

Lower ambient temperature - Freeze risk

Make sure that the watering system is empty/drained of water (sprinkler, hoses, tank/s) or that anti-freeze has been added, to prevent the system freezing.

The outlet hose from the central tank can be disconnected and the end placed in a container with antifreeze to run this through the pump/filter.

Temperatures

The temperature limits apply to standard versions of rollers.

Rollers equipped with additional equipment, such as noise suppression, may need to be more carefully monitored in the higher temperature ranges.

Machine description

Identification

Product identification number on the frame

The machine PIN (Product Identification Number) (1) is punched on the right edge of the front frame.

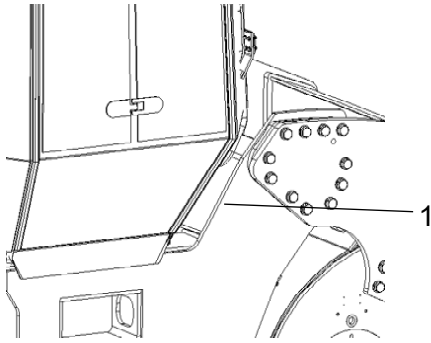
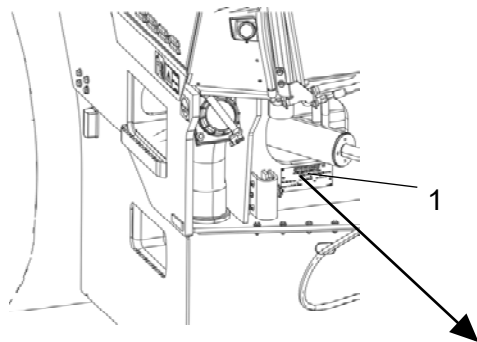

Fig. PIN Front frame

Machine plate

The machine type plate (1) is attached to the front left side of the frame, beside the steering joint.



The plate specifies among other things the manufacturer's name and address, the type of machine, the PIN, Product Identification Number (serial number), operating weight, engine power and year of manufacture. (In some cases there are no CE marking.)



**Fig. Operator platform
1. Machine plate**

DYNAPAC			
Dynapac Compaction Equipment AB Box 504, SE-371 23 Kurlåkra, Sweden			
Product Identification Number			
Designation	Type	Rated Power	Max axle load front / rear
		kW	kg
Gross machinery mass	Operating mass	Max ballast	Year of Mfg.
kg	kg	kg	
Made in Sweden <small>8811 0001 00</small>			

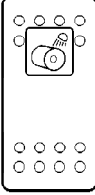
Please state the machine's PIN when ordering spares.

No	Designation	Symbol	Function
31	Edge press/cutter, sprinkling		Activate edge press/cutter sprinkling by depressing the switch.
32	Drum edge lights		Activate the drum edge lights by depressing the switch.
35	Sprinkler combi wheel		Activate the emulsion sprinkler for combi wheels by depressing the switch.

Display explanations



Fig. Start screen

When the ignition key is activated to position I, a start screen is visible in display. This is shown for a few seconds and then switches over to the status screen.









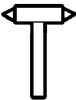

Fig. Status screen

A status screen provides information on the fuel level, water level in the sprinkler tank, machine hours and voltage level. Fuel and water levels are specified in per cent (%).

This screen is active until the Diesel engine is started or an active screen choice is made via the function buttons below the display.

Function description of instruments and controls in the cab

No	Designation	Symbol	Function
1	Heater control		Turn to the right to increase heating. Turn to the left to reduce heating.
2	Ventilation fan, switch		In the left position, the fan is off. Turning the knob to the right increases the volume of air entering the cab.
3	Air conditioning, switch		Starts and stops the air conditioning.
4	Cab air recirculation, switch		Pressing the top opens the air damper so that fresh air comes into the cab. Pressing the bottom closes the damper so that the air recirculates inside the cab.
5	Front wiper, switch		Press to operate the front screen wiper.
6	Front and rear window screen washers, switch		Press the upper edge to activate the front screen washers. Press the lower edge to activate the rear screen washers.
7	Rear wiper, switch		Press to operate the rear screen wiper.
8	Fuse box		Contains fuses for the electrical system in the cab.
14	Defroster nozzle		Turn the nozzle to direct the flow of air.
15	Hammer for emergency exit		To escape from the cab in an emergency, release the hammer and break the opening windows on the right-hand side.

CLICK HERE TO **DOWNLOAD** THE COMPLETE MANUAL

- Thank you very much for reading the preview of the manual.
- You can download the complete manual from: www.heydownloads.com by clicking the link below



- Please note: If there is no response to CLICKING the link, please download this PDF first and then click on it.

CLICK HERE TO **DOWNLOAD** THE COMPLETE MANUAL

Display when activating choice via the button set.

The parking symbol is shown when the parking brake is activated.

= Operating position, off-set, vibration and sprinkling possible. The symbol flashes in off-set mode, in neutral (reset off-set) the symbol shines constantly.

= Automatic Water Control (AWC), sprinkling is activated when the F/R lever is outside neutral.

= High amplitude

= Vibration on front and rear drum.

= Automatic Vibration Control (AVC), vibration is activated when the F/R lever is outside neutral.

= Display of alarm, see table for information.

Alarm descriptions

Symbol	Designation	Function
	Warning lamp, hydraulic filter	If the lamp comes on while the engine is running at full speed, the hydraulic filter must be changed.
	Warning lamp, air filter	If the lamp comes on while the engine is running at full speed, the air filter must be cleaned or replaced.
	Warning lamp, battery charging	If the lamp comes on while the engine is running, the alternator is not charging. Stop the engine and locate the fault.
	Warning light, engine temperature	If the lamp comes on, the engine is too hot. Stop the engine immediately and locate the fault. Refer also to the engine manual.
	Warning lamp, hydraulic fluid temperature	If the lamp comes on, the hydraulic fluid is too hot. Do not drive the roller. Cool the fluid by allowing the engine to idle and locate the fault.

Miscellaneous

Lifting

Locking the articulation

 **Articulation must be locked to prevent inadvertent turning before lifting the roller.**

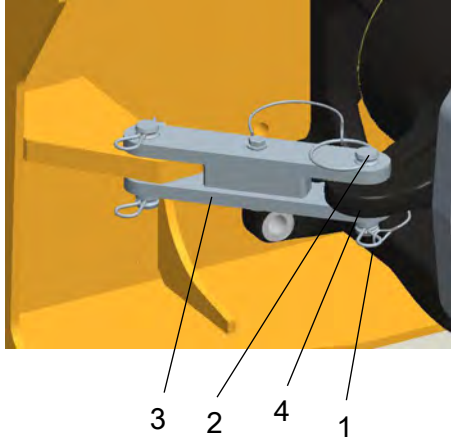

Fig. Articulation in the locked position

1. Locking pin
2. Locking dowel
3. Locking arm
4. Locking lug

Turn the steering wheel to the straight ahead position. Push in the emergency/parking brake knob.

Pull out the lowermost locking pin (1), which has a wire attached. Pull up the locking dowel (2) which also has a wire attached.

Fold out the locking arm (3) and secure it to the upper locking lug (4) on the articulated link.

Fit the locking dowel into the holes through the locking arm and locking lug. Lock the dowel in position with the locking pin (1).

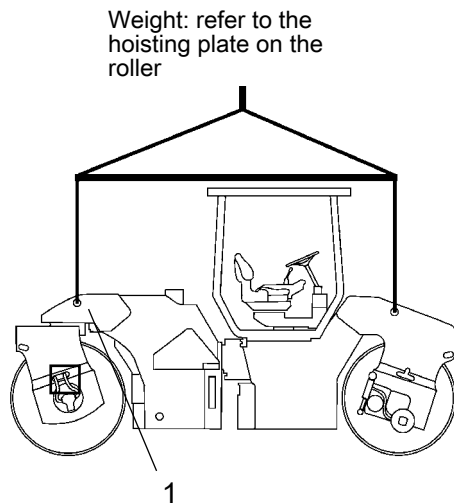



Fig. Roller prepared for lifting
1. Hoisting plate

Lifting the roller

 **The machine's gross weight is specified on the hoisting plate (1). Refer also to the Technical specifications.**

 Lifting equipment such as chains, steel wires, straps and lifting hooks must be dimensioned in accordance with the relevant safety regulations for the lifting equipment.

 **Stand well clear of the hoisted machine! Make sure that the lifting hooks are properly secured.**

Maintenance - Lubricants and symbols

Fluid volumes

Drum		
- Drum	13 liters	13.7 qts
- Drum gear	0,8 liters	0.85 qts
Wheels		
- Wheel gear (x2)	0,8 (x2) liters	0.85 (x2) qts
Hydraulic reservoir	40 liters	42 qts
Diesel engine		
- oil	7 liters	7.4 qts
- coolant, no cab	18,6 liters	19.7 qts
- coolant, with cab	20,1 liters	21.2 qts







Always use high-quality lubricants and the amounts recommended. Too much grease or oil can cause overheating, resulting in rapid wear.



Other fuel and lubricants are required when operating in areas with extremely high or extremely low ambient temperatures. See the 'Special instructions' chapter, or consult Dynapac.

DYNAPAC

 ENGINE OIL	Air temperature -15°C - +50°C (5°F-122°F)	Shell Rimula R4 L 15W-40, API CH-4 or equivalent.
 HYDRAULIC FLUID	Air temperature -15°C - +40°C (5°F-104°F)	Shell Tellus T68 or equivalent.
	Air temperature over +40°C (104°F)	Shell Tellus T100 or equivalent.
 BIOLOGICAL HYDRAULIC FLUID <small>Bio-Hydr.</small>	When it leaves the factory, the machine may be filled with biologically degradable fluid. The same type of fluid must be used when changing or topping up.	BP BIOHYD SE-S 46
BIOLOGICAL HYDRAULIC FLUID, PANOLIN	When it leaves the factory, the machine may be filled with biologically degradable fluid. The same type of fluid must be used when changing or topping up.	PANOLIN HLP Synth 46 (www.panolin.com)
 DRUM OIL	Air temp. -15°C - +40°C (5°F-104°F)	Mobil SHC 629
		Dynapac Drum Oil 100 , P/N 4812156456 (5 liter), P/N 4812156457 (20 liter)



Hydraulic reservoir - Check fluid level

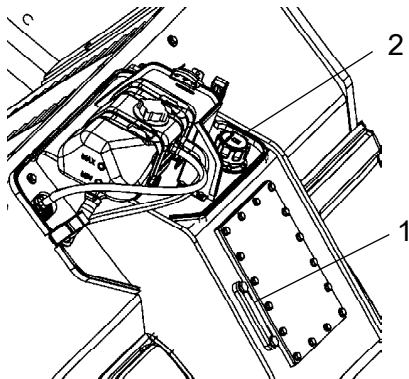

Figure. Hydraulic reservoir
1. Oil sight glass
2. Filler cap

Place the roller on a level surface and check that the oil level in the sight glass (1) is between the max and min markings. Top up with the type of hydraulic fluid specified in the lubricant specification, if the level is too low.



Water tank, Std - Filling

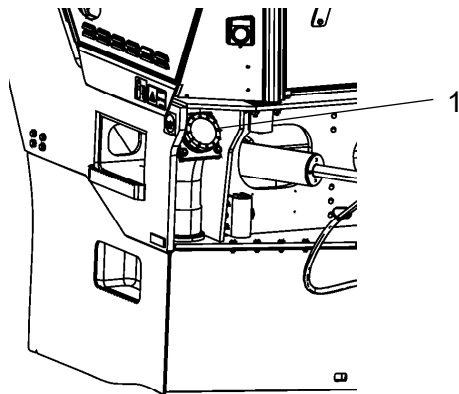

Figure. Standard water tank
1. Tank cap

The filler cap is on the rear left side of the front frame.



Unscrew the tank cap (1) and fill with clean water. Do not remove the strainer (2).

Fill the central (standard) tank, it holds 750 liters (198 gal).



Only additive: A small amount of environment-friendly antifreeze.



Fuel filter - Draining

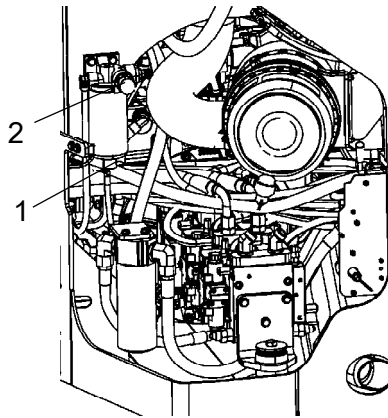

Figure. Fuel filter
1. Drain plug
2. Hand pump

Unscrew the drain plug (1) at the bottom of the fuel filter.

With the aid of the secondary hand-operated pump, make certain that all sediment comes out. See Cummins service manual.

Tighten the drain plug as soon as uncontaminated fuel runs out.

Drum gear - Checking the oil level

Move the machine until the inspection/filling holes are in position for filling.

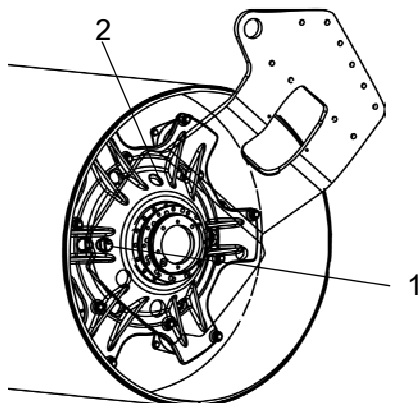

Fig. Oil level check - drum gear
1. Level plug
2. Filling plug

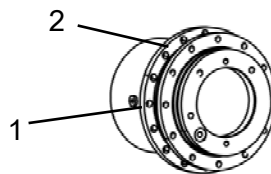

Fig. Drum gear

Refill with new oil, about 1 l (1.1 qts). Use transmission oil according to the lubricant specification.

Ensure that the oil level reaches up to the lower edge of the plug hole.

Clean and refit the plugs.

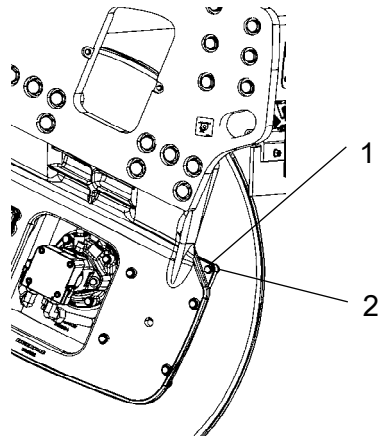

Fig. Drum, vibration side
1. Rubber element
2. Attachment screws

Rubber elements and attachment screws Check

Check all rubber elements (1). Replace all elements if 25% or more than 25% of the number on one side of the drum have cracks deeper than 10-15 mm (0.4-0.6 in).

Check using a knife blade or pointed object.

Check also that the attachment screws (2) are tightened.



Hydraulic reservoir cap - Check

Turn up the machine so that the tank cap is accessible from the left side of the machine.

Unscrew and make sure that the reservoir cap is not clogged. Air must have unobstructed passage through the cap in both directions.

If passage in either direction is blocked, clean the filter with a little diesel oil and blow through with compressed air until the block is removed, or replace the cap with a new one.



Wear protective goggles when working with compressed air.

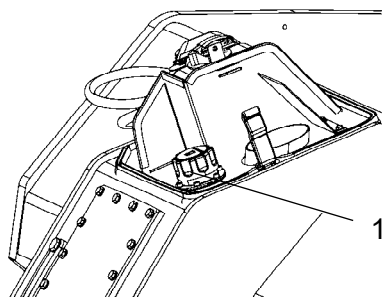

Figure. Rear frame front left side
1. Tank cap

CLICK HERE TO **DOWNLOAD** THE COMPLETE MANUAL

- Thank you very much for reading the preview of the manual.
- You can download the complete manual from: www.heydownloads.com by clicking the link below



- Please note: If there is no response to CLICKING the link, please download this PDF first and then click on it.

CLICK HERE TO **DOWNLOAD** THE COMPLETE MANUAL