

***DOOSAN***

950106-00258ANA  
July 2014

EXCAVATOR

**Operation &  
Maintenance  
Manual**

**DX490LC-3 / DX530LC-3**

**Serial Number 10001 and Up**

CLICK HERE TO **DOWNLOAD** THE COMPLETE MANUAL

- Thank you very much for reading the preview of the manual.
- You can download the complete manual from: [www.heydownloads.com](http://www.heydownloads.com) by clicking the link below



- Please note: If there is no response to CLICKING the link, please download this PDF first and then click on it.

CLICK HERE TO **DOWNLOAD** THE COMPLETE MANUAL

## Component Model and Serial Numbers

There are model and serial numbers on each traceable component of machine. For example, the engine serial number is stamped on rear left side of the engine block, above the starter. Additional engine information is described on a label (Figure 3) on head cover.

Record these numbers and their locations. These will be required whenever warranty or service work is requested.

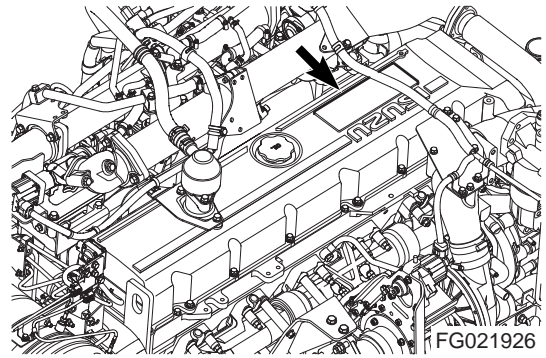

Figure 3

## Safety Messages

Safety messages and safety decals included in this manual and on the machine provide instructions how to operate, service and maintain the machine. Safety messages and safety decals indicate potential hazards and describe safety precautions required to avoid hazards. Operator and maintenance personnel should read and understand these safety messages and decals before beginning operation or maintenance.



---

**Be Prepared - Get to Know All Operating and Safety Instructions.**

**This is a Safety Alert Symbol. Wherever it appears in this manual or on safety decals on the machine, you must be alert to the potential for personal injury or accidents. Always observe safety precautions and follow recommended procedures.**

---

### Signal Words

The signal words "DANGER", "WARNING", "CAUTION" are used throughout safety messages and safety decals in this manual or on the machine. They indicate an existence of, and the relative seriousness of, a hazard. All three indicate that a safety risk is involved. Observe the precautions indicated whenever a Safety Alert Symbol is present, no matter which signal word appears next to it.

---



---

**DANGER - This signal word is used on safety messages and safety labels and indicates an imminently hazardous situation which, if not avoided, will result in death or serious injury.**

---

### Safety Decals Without Text (No-Text)

Safety decals without text consist of a safety sign and safety information panel. The safety sign panel is located at the top or left side and the safety information panel is located at the bottom or right side of the decal depending on its configuration. The safety sign panel uses a black triangular band and a pictorial to identify the hazard and the potential consequences of the failure to follow instructions. The safety information panel uses pictorials and/or prohibition signs to identify the actions necessary to avoid the hazard.

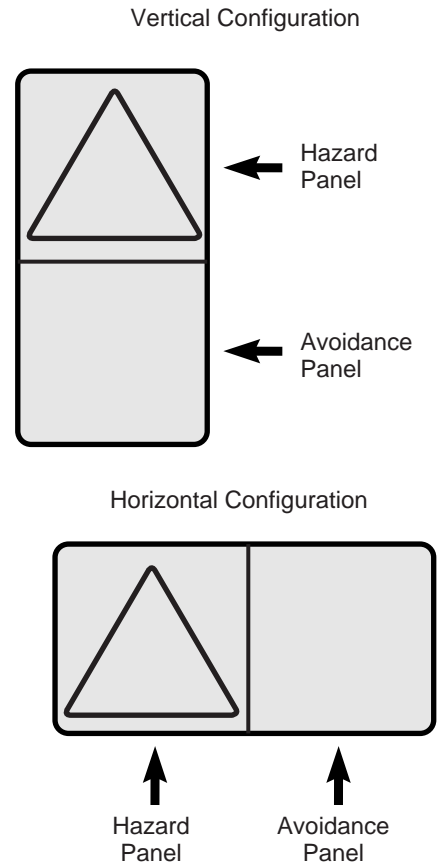

FG018723

Figure 1

19. Falling Object (Optional) (950205-03786)



## WARNING

**UNSUPPORTED DOOR CAN FALL CAUSING  
DEATH OR SERIOUS INJURY**

- To open door:
  - 1) Hold door firmly.
  - 2) Lift door slowly until locking device engages.
- To close door:
  - 1) Hold door firmly.
  - 2) Press locking device to disengage.
  - 3) Lower door slowly.



EX1301198

20. Hydraulic Oil Check (Optional) (950205-03965)

## IMPORTANT

**INCORRECT OIL LEVEL OR INCORRECT FLUID CAN  
CAUSE HYDRAULIC SYSTEM DAMAGE**

Place the excavator with the boom and arm fully extended with the attachment on the ground before checking hydraulic fluid level.

Use only ISO VG#46 hydraulic fluid.

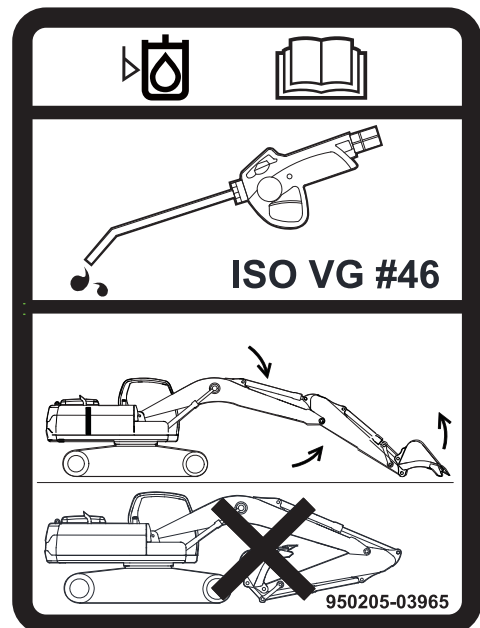

EX1301199

## If a Fire Occurs

If a fire occurs:

- Do not attempt to move machine or continue operations.
- Turn starter switch to "O" (OFF) position to stop engine.
- Use handrails, guardrails and steps to get off machine.
- Immediately call for help or fire station.
- When using a fire extinguisher, always aim extinguisher at base of fire.
- If an optional fire extinguishing system is in place, be familiar with its operating procedures.

**NOTE:** Depending on job conditions, other procedures could be necessary if a fire occurs.



FG018459

Figure 16

## Fire Extinguisher and First-Aid Kit (Emergency Medical Kit)

To be prepared in the event of a fire:

- Be sure that fire extinguishers have been provided and read labels to ensure that you know how to use them. It is recommended that an appropriately sized (2.27 kg [5 lb] or larger) multipurpose A/B/C fire extinguisher be mounted in cabin. Check and service fire extinguisher at regular intervals and make sure that all work site crew members are adequately trained in its use.
- Inspect fire extinguisher and service fire extinguisher regularly.
- Follow instructions on extinguisher instruction plate.
- Keep a first aid kit in storage compartment (Figure 18) and keep another kit at work site. Check kit periodically and keep it properly supplied.
- Keep emergency numbers for doctor, ambulance service, hospital and fire department readily available.

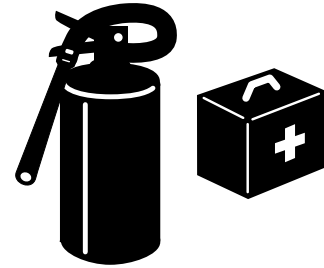

HGO1009L

Figure 17

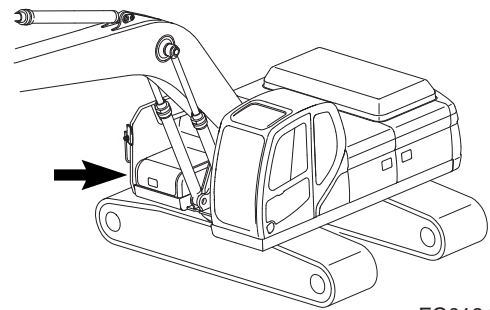

FG018460

Figure 18

## Cleaning

Remove all straw, wood chips, leaves, grass, paper and other flammable debris accumulated in engine compartment, Diesel Particulate Filter (DPF), mufflers and around battery. Remove any dirt from window glass, mirrors, handrails, and steps.

Do not leave tools or spare parts in operator's cabin. Vibration of machine during operation can cause tools or spare parts to fall and damage or break control levers or switches. Tools and spare parts can also get caught in spaces between control levers and cause accidental movement of work equipment causing death or serious injury.

When entering operator's cabin, always remove all mud and oil from your shoes. If you operate travel pedal with mud or oil stuck to your shoes, your foot could slip off the control, or dirt and debris may interfere with proper operation of control levers.

After using ashtray, make sure that any matches or cigarettes are properly extinguished, and be sure to close ashtray.

Clean window glass and working lights for good visibility.

Do not stick suction pads to window glass. Suction pads act as a lens and can cause fire.

Never bring flammable or explosive items into operator's cabin. Do not leave cigarette lighters laying around operator's cabin. If temperature inside operator's cabin becomes too high, there is a potential hazard that lighter could explode.

Secure all loose items such as lunch boxes, and other items that are not a part of equipment.

## Operator Station

Inspect condition of seat belt and mounting hardware. Replace any parts that are worn or damaged. Do not use a seat belt extension on a retractable seat belt.

Adjust seat so full pedal travel can be achieved with operator's back against back of seat.

Keep all windows and doors closed on machine.

Adjust operator's seat to a position where it is easy to perform operations, and check that there is no damage or excessive wear to seat belt or mounting clamps.

Adjust and clean mirrors so area to rear of machine can be seen clearly from operator's seat.

When standing up from operator's seat, always place safety lock lever securely in "LOCK" position. If you accidentally move work equipment levers when they are not locked, the machine could suddenly move and cause damage, death or serious injury.

## Attachment

Never let anyone ride on any work attachment, such as bucket, crusher, grapple, or clamshell (grab bucket). This creates a falling and crushing hazard, and can result in death or serious injury.

The clamshell, grapple, or magnet can swing in all directions. Move work levers (joysticks) in a continuous motion. Failure to move work levers (joysticks) in a continuous motion can cause clamshell, grapple, or magnet to swing into cabin or into a person in work area. This can result in death or serious injury.

- When using a fork or grapple, do not attempt to pick up an object with its tips. This could damage the machine or cause personal injury, if picked-up object slips off attachment.
- Do not use impact force of work equipment for demolition work. This could damage work equipment, cause broken materials to fly off or tipping. This could result in death or serious injury.
- Do not use work equipment or swing mechanism to pull load in any direction. This could cause the work equipment to move suddenly if the load releases and can result in death or serious injury.

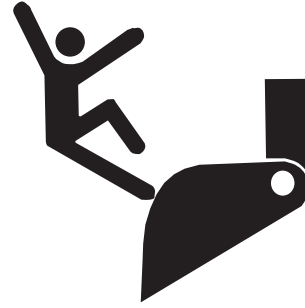

Figure 34

ARO1310L

## Equipment Lowering with Engine Stopped

Before lowering any equipment with the engine stopped, clear the area around the equipment of all personnel and bystanders. The procedure to use will vary with the type of equipment to be lowered. Keep in mind most systems use a high-pressure fluid or air to raise or lower equipment. The procedure will cause high-pressure air, or hydraulic pressure, or some other media to be released to lower the equipment.

Wear appropriate personal protective equipment and follow the established procedure in the Operation and Maintenance Manual "Equipment Lowering with Engine Stopped" on page 3-72 in the Operation Section of the manual.

## Engine Stop

Turn engine starter switch to "O" (OFF) position and remove engine starter switch key.

Before lowering any equipment with engine stopped, clear area around equipment of all personnel and bystanders. This procedure will cause high-pressure air or hydraulic pressure to be released to lower equipment.

Do not stop engine immediately after the machine has been operated under load. This can cause overheating and accelerated wear of engine components.

After the machine is parked, allow engine to run for five minutes before stopping the engine. This allows hot areas of engine to cool gradually.

- Do not leave operator's seat when there is a raised load.

## Rubber That Contains Fluorides

Observe extra great care when it is suspected that you may have to handle rubber that contains fluorides.

Certain seals which have to withstand high operating temperatures (e.g. in engines, transmissions, axles, hydraulic motors and pumps) may be made from rubber that contains fluorides, which, when exposed to high heat (fire), forms hydrogen fluoride and hydrofluoric acid. This acid is very corrosive and cannot be rinsed or washed off from the skin. It causes very severe burns which take a long time to heal.

It usually means that damaged tissue must be surgically removed. Several hours may pass after contact with the acid, before any symptoms appear and therefore one is not given any immediate warning. The acid may remain on the machine parts for several years after a fire.

If swelling, redness or a stinging feeling appears and one suspects that cause may be contact with heated rubber that contains fluorides, contact a medical doctor immediately. If a machine, or part of a machine, has been exposed to fire or severe heat, it must be handled by specially trained personnel. In all handling of machines after a fire, thick rubber gloves and protective goggles must be used.

The area around a part which has been very hot and which may be made of rubber that contains fluorides must be decontaminated by thorough and ample washing with limewater (a solution or suspension of calcium hydroxide, i.e. slaked lime in water). After the work has been completed, the gloves must be washed in limewater and then discarded.

# ENVIRONMENT AND CIRCUMSTANCES

## Work Site Areas Requiring Extra Caution

- Do not operate too close to edge of a quay, ramp, etc.
- Do not operate too close to edge of a steep slope or drop-off. Take care when working in a place where machine may tip over.
- Do not operate on soft ground or near riverbanks that could collapse or where ground may not support weight of excavator.
- Observe changes in ground and traction conditions after a rain or other changes in weather.

## Digging Under an Overhang

Do not dig work face under an overhang. This can cause overhang to collapse and fall on top of the machine.

- Do not perform overhead demolition work. This can cause broken objects and debris to fall on top of machine causing death or serious injury, or property damage.

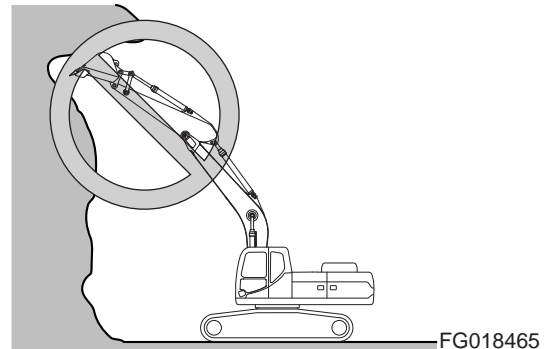

Figure 52

## Deep Digging

Do not perform deep digging under front of machine. The ground under machine may collapse and cause machine to fall resulting in death or serious injury.

Working heavy loads on loose, soft or uneven ground, can cause side load conditions resulting in a tip over and injury. Traveling without a load or a balanced load may also be hazardous.

Never rely on lift jacks or other inadequate supports when work is being done. Block tracks fore and aft to prevent any movement.

Use machine only for its intended purpose. Using it for other purposes will cause failures.

- Do not perform demolition work under machine. There is a hazard that the machine may become unstable and tip over.
- When working on or from top of buildings or other structures, check if structure can support weight of machine and attachment. If a building structure collapses, this can cause death or serious injury.

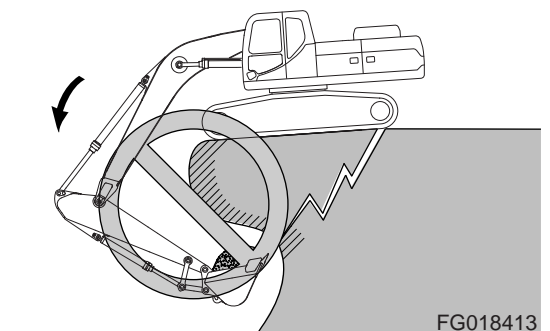

Figure 53

## Sound

Sound Level Information: Hearing protection may be needed when machine is operated with an open operator station for extended periods or in a noisy environment.

Sound pressure level (LpA) at operator position (Measurement according to ISO 6396)	71 dB(A)
Sound power level (LwA) around the machine (Measurement according to 2000/14/EC with applicable appendices and measuring method according to ISO 6395)	107 dB(A)

## Vibration

Hands and Arms: The weighted root mean square acceleration to which hands and arms are subjected, is less than 2.5 m/s<sup>2</sup>.

Whole Body: The weighted root mean square acceleration to which whole body is subjected, is less than 0.5 m/s<sup>2</sup>.

Measurements are obtained on a representative machine, using measuring procedures as described in the following standard: ISO 2631/1, ISO 5349, and SAE J1166.

Recommendations for Reducing Vibrations:

1. Select proper machine, equipment and attachments for a particular application.
2. Replace any damaged seat with a genuine DOOSAN seat. Keep seat properly maintained and adjusted.
  - Adjust seat and suspension for weight and size of operator.
  - Inspect and maintain suspension and adjustment mechanisms for seat regularly.
3. Check that the machine is properly maintained.
4. Operate controls smoothly when; steering, accelerating, slowing down, loading, or moving attachments.
5. Adjust machine speed and travel path to reduce vibration level.
  - Slow down when traveling over rough terrain or long distances.
  - Avoid obstacles and rough terrain.
6. Keep machine on and maintain designated travel path when traveling.
  - Remove large rocks or obstacles.
  - Fill ditches and holes.
  - Use other machines to maintain the travel path for the excavator.

### 3. Power Socket for 12 Volt

This is a power socket for only 12V DC devices.

This socket can be used for charging a cellular phone or powering a small 12V DC electrical device.

Open the cap when using it.

**NOTE:** *Avoid damage to electrical system. This socket is designed for small electrical capacity devices only. Do not use this socket for large electrical capacity devices.*

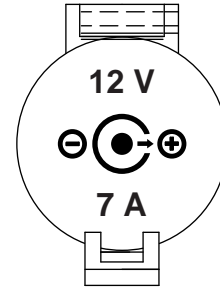

FG017015

Figure 6

### 4. Cigarette Lighter

Push the lighter all the way into the socket and release. After pushing it in, it will be ejected when it is heated. If it does not eject after a short time, pull it out and have it serviced.

**NOTE:** *This cigarette lighter is for 24V only. Never connect a 12V electrical device to the lighter.*

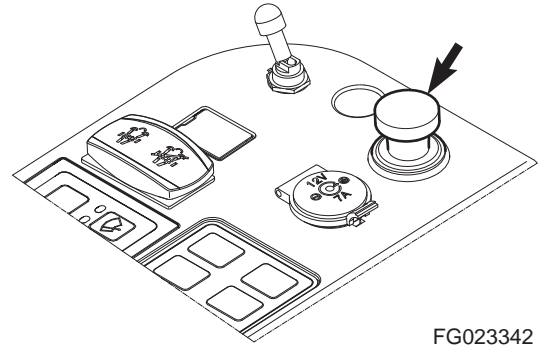

FG023342

Figure 7

### 5. Engine Emergency Stop Switch

If the engine does not stop when using the starter switch, it can be stopped by moving the engine emergency stop switch to "I" (EMERGENCY STOP) position.

- O. In this position, the engine emergency stop system is "OFF".
- I. In this position, "EMERGENCY STOP" is selected. The engine will stop.

**NOTE:** *When released, the switch will return to its original position "O" (OFF) position.*

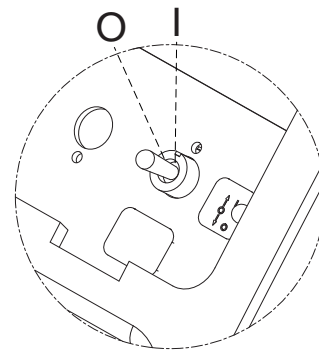

FG016039

Figure 8

## 27. Safety Lever

See "Safety Lever" on page 3-17.

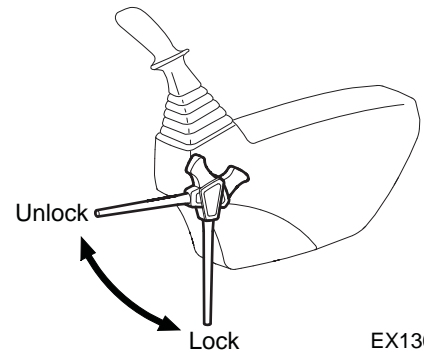

EX1300566

Figure 37

## 28. Auxiliary Mode Switch

When the control system is out of order, the pump system can be controlled manually.

- O. In this position, the manual pump control is "OFF".
- I. In this position, the manual pump control is "ON".

---

### IMPORTANT

---

**Be sure to turn pump control to "O" (OFF) position, after the control system is operating properly.**

---

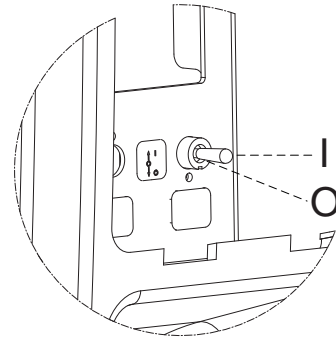

FG016041

Figure 38

which will damage the engine. Allowing the engine to idle will dissipate heat. Check the coolant level, look for a loose fan belt, inspect for debris around radiator, etc.

When the temperature reaches the normal range, the engine speed will automatically recover.

### 3. Hydraulic Oil Temperature Gauge

The colored bands indicate the temperature of the hydraulic oil.

WHITE ZONE (□) - Indicates temperature is within the normal operating range.

RED ZONE (■) - Indicates temperature is too high.

During operation, the pointer must be in the white zone.

If the gauge pointer moves into the red zone, the hydraulic oil temperature symbol will turn "ON", and be display in the screen. Allow the engine to run at "LOW IDLE" until temperature gauge registers in the white zone again.

**NOTE:** See "7. Display Warning Symbols" on page 2-32, for location of this warning symbol and others.

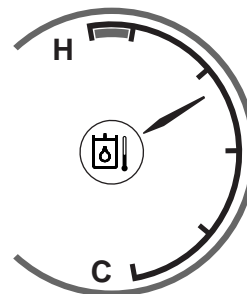

FG018117

Figure 59

### 4. Multifunction Gauge and Graphic Information Area

When the engine starter switch is turned to "I" (ON) position, a LOGO will appear on the display screen for about two seconds.

When the LOGO disappears, the multifunction gauge and graphic information screen will appear.

The engine rpm is normally displayed at the bottom of the screen when the starter switch is first turned "ON". A digital clock is located at the top of the display.

By using a combination of the mode selector buttons, information for filters and oils can also be displayed.

The display can also be set for the desired language.

Refer to the "User Menu" on page 2-46 for the language selection and information display sequences.

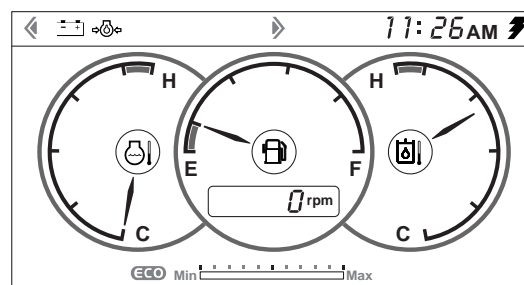

FG018118

Figure 60

## 9. Function Buttons

The function buttons has the same functionality as that of a jog switch.

### How to Use Function Button

Pressing function button will display "Function Bar" at bottom of screen.

For symbols on function bar, commands can be entered using buttons F1 - F6 in the same positions.

Reference Number	Description
1	Menu 2 Selector Button
2	Power Mode Selector Button
3	Auto Idle Selector Button
4	Work Mode Selector Button
5	Selection Bar Move (◀) Button
6	Selection Bar Move (▶) Button
7	Menu Selector Button
8	Camera Mode Selector/Escape (ESC) Button
9	Entertainment Button
10	Menu 1 Selector Button

#### 1. Menu 2 Selector Button

Press this button to change from menu 1 to menu 2.

#### 2. Power Mode Selector Button

Used for selecting the power plus mode, power mode, standard mode, or the economy mode.

Pressing the power mode selector button will display the available modes on the main window.

Place the selection bar by selection bar move button (5, 6) and select the mode by pressing menu selector button (7).

#### 3. Auto Idle Selector Button

When the auto idle system is activated, the engine will automatically reduce speed to "IDLE" approximately four (4) seconds after all the control levers are in the "NEUTRAL" position. This system is designed to reduce fuel consumption and noise.

When the auto idle selector button is pushed to "ON" position, an indicator light above it turns "ON".

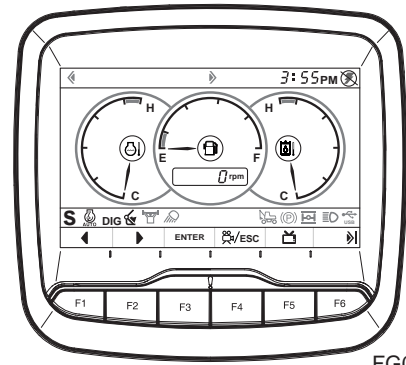

Figure 86

FG018129

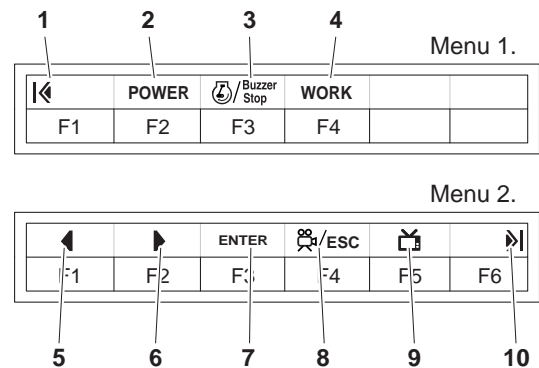

Figure 87

FG018652

## Symbol Description

Filter/ Oil Name	Fuel Filter	Air Cleaner	ENG Oil Filter	Return Filter	Pilot Filter	ENG Oil	HYD. Oil	Coolant Water	DPF Filter
Icon									

FG018453

**Figure 107**

If the remaining time for filter/oil replacement is less than 10 hours, this pop-up window will be created. Press the ESC button or the jog switch to allow the pop-up window to disappear.

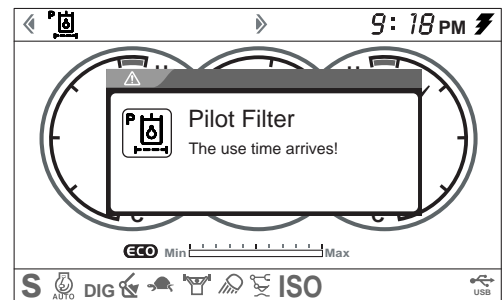

FG018516

**Figure 108**

If the filter/oil replacement period is expired, this pop-up window will be created.

Press the ESC button or the jog switch to allow the pop-up window to disappear.

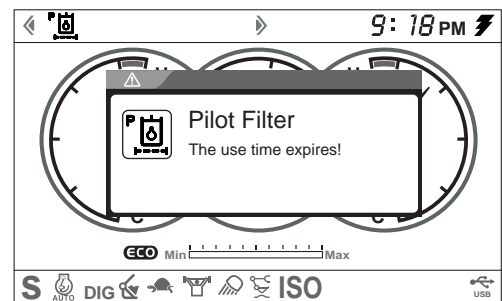

FG018515

**Figure 109**

If the filter/oil replacement period is exceeded, this pop-up window will be created. Press the ESC button or the jog switch to allow the pop-up window to disappear.



## WARNING

**AVOID DEATH OR SERIOUS INJURY**

**Do not use vehicle state menu when traveling or operating.**



FG018517

**Figure 110**

If the format is not supported, a pop-up window is displayed for 3 seconds, saying "This file is not available!" and the video is not played.



FG020115

Figure 141

Formats that can be supported are given below.

Formats that can be supported	
File Type	AVI (DIVX), MP4, WMV (VERSION 8)
Supported Resolution	720*480, 720*384, 720*304, 704*448, 704*304, 640*480, 640*360, 640*272, 640*352, 672*288, 512*384, 576*432, 480*320, 480*360, 320*240
Supported Video Codec	H.264 (ITU H.264 BASELINE L1.3, L3.0), MPEG4, DIVX4.0, 5.0, WMV8, Xvid
Supported Audio Codec	MPEG L3, AAC
MP3 Bit Rate	128 - 320 kbps
Supported File Size	Under 1.7 GB

The screen composition of the video player is given below.

The top section displays the name of the file being played and the current playing time of the total playing time.

The screen center shows the video being played.

The bottom displays the video player function operation symbol and cursor.

The video player function operation symbol and jog switch are operated in the following order.

**Play/Pause** ↔ **Replay the Previous File** ↔ **Video Progress Bar** ↔ **Replay the Next File** ↔ **Video Files List** ↔ **Adjust Video Brightness**

If no operation continues for more than 5 seconds, the video will automatically be converted into the whole screen.

On the whole screen, click on the jog switch or the ESC button to remove whole screen.

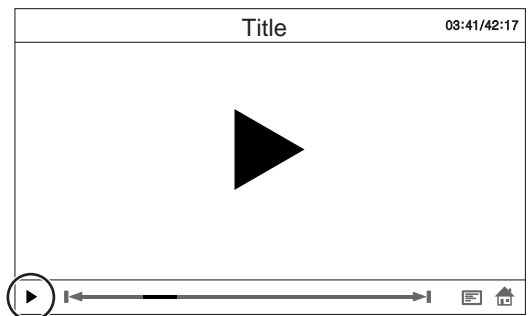

FG020116

Figure 142

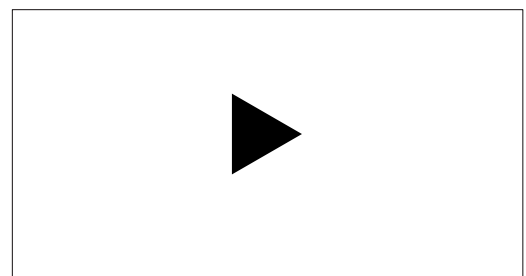

FG018214

Figure 143

C. Default Screen Setting

On the GP configuration screen, when cursor is placed on default screen setting, click on the jog switch to access the default screen setting.

On the default screen setting, turn the jog switch and locate the cursor at a desired style. Then, click on the jog switch to select the style.

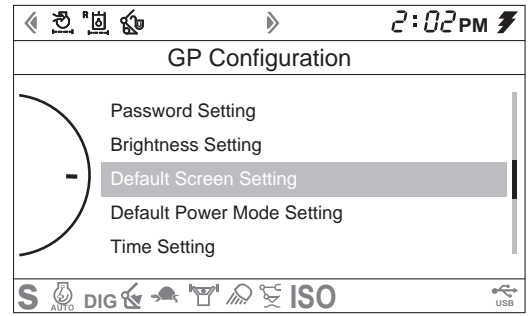

FG022140

Figure 177

The selected style screen is displayed as the normal display screen.

The screen when manufactured is set as #1 style.

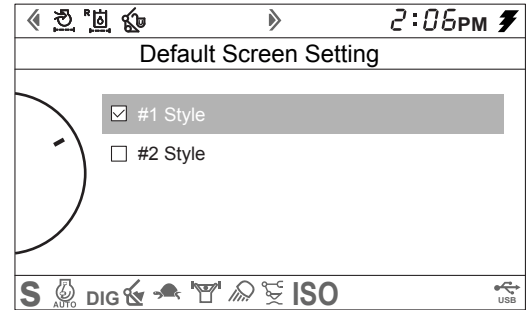

FG018536

Figure 178

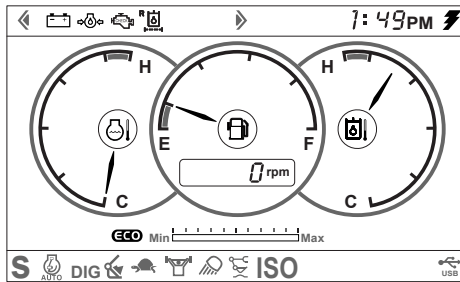

<1 Style>

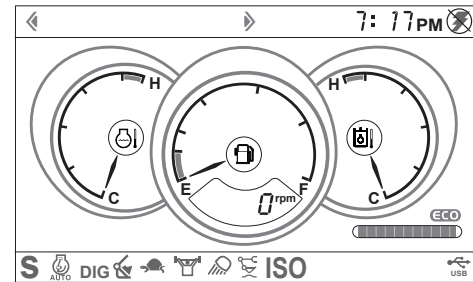

<2 Style>

FG018537

Figure 179

## 2. Off Button

This button is used to stop the fan and air conditioner.

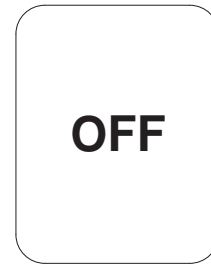

FG000089

Figure 210

## 3. Temperature Control Button

These buttons are used to control the cabin temperature.

Temperature is adjustable from 17°C (62°F) to 32°C (90°F) by 0.5°C (1°F) increments.

Temperature setting is displayed on the LCD.

When the system is turned "ON", the previously set temperature is used as a starting point.

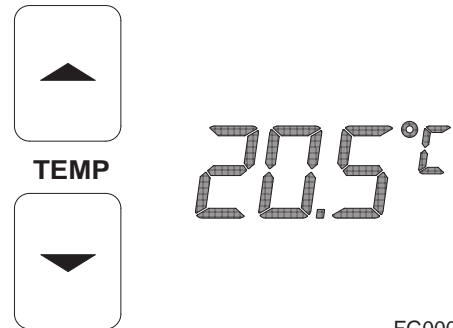

FG000090

Figure 211

## 4. Temperature Unit Selector Button

This button gives the choice to select either °C or °F.



FG000094

Figure 212

## 5. Mode Selector Button

This button is used to select which combination air outlets will be used.



FG000096

Figure 213

## Seat Belt Locking and Unlocking

Insert belt end (1, Figure 236) into buckle (2, Figure 236). Pull belt to check that belt end is locked into buckle.

Adjust belt length so it is comfortably tight against operator's pelvic region (hipbone).

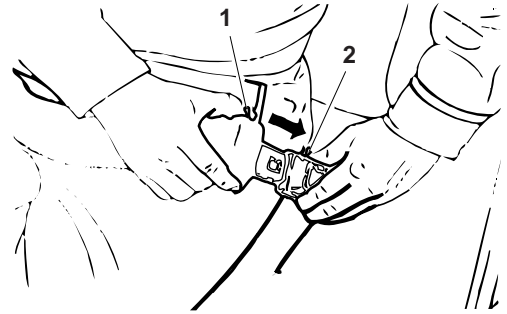

HAOB140L

Figure 236

Press button (3, Figure 237) in center of buckle (2, Figure 237) and pull out belt (1, Figure 237) to unlock.

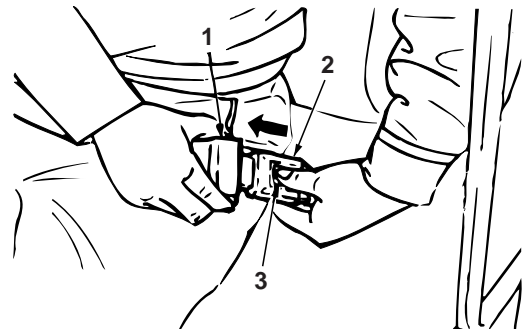

HAOB150L

Figure 237

## 7. Storage Compartment

The seat has a storage compartment (1, Figure 238). It is used for storing the Operation and Maintenance Manual and Safety Manual.

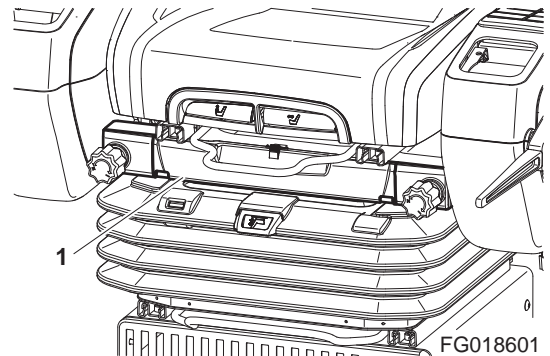

FG018601

Figure 238

## 8. Left and Right Control Stand Adjustment

For operator's convenience, the right and left control stands and seat can slide together, within a 160 mm (6.3 in) forward or backward travel distance.

Holding lever (1, Figure 239), raise it up, set the seat to desired position. Release lever to lock seat in selected position.

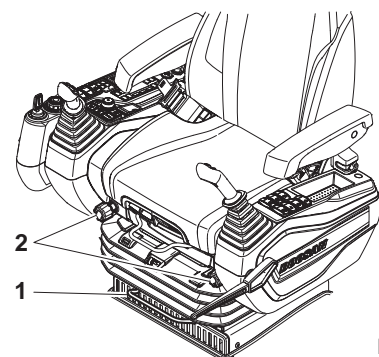

FG018573

Figure 239

# Operation

## TO OPERATE A NEW EXCAVATOR

All DOOSAN excavators are inspected before leaving the factory. However, it is required that operator follow these steps during the initial break-in period. Failure to follow these steps can result in damage to the equipment or reduced performance.

Hour	Load
For first 50 hours of operation	Maintain about 80% load of full capacity (Engine rpm: 80% of rated rpm)
After first 50 hours of operation	Full load

If machine is used at full load before it is broken in, it could affect the overall performance and service life of the machine.

- NOTE:**
1. *Check daily for leakage of coolant, fuel, engine oil and hydraulic oil.*
  2. *Inspect all lubricants daily and add appropriate lubricants as required.*
  3. *During operation, monitor all instruments and gauges from time to time.*
  4. *Avoid an extreme engine load.*
  5. *Operate unit at 80% load until engine and all other components are at operating temperatures.*
  6. *Check that work equipment is operating normally.*
  7. *Check machine for loose parts or for damage that may have occurred during shipping.*
  8. *Check for loose wiring or terminals, check gauge operation and battery electrolyte level.*



### 3. Operation

While the battery disconnection switch is "ON", the engine coolant heater can be started-up by the following modes:

- A. Manual mode: The operator operates the heater by switching "ON/OFF" directly.



Pressing the (  ) button turns on the heater, and pressing it once again will turn it off.

- B. Auto mode: The heater turns on or off at preset time.



Pressing the ( **P** ) button will make the program number blink. Set up the starting time using the left (  ) or right (  ) button.

Keep press the ( **P** ) button to set up program numbers 2 and 3, or switch to time mode.

- C. Operating mode: The heater will operate for desired time.

With the heater off, press the left (  ) button for 3 seconds. While the operating time is blinking, set up the desired operating time using the left (  ) or right (  ) button. (10 - 120 minutes).

- D. Residual time setting

While the heater is operating, set up the required residual time using the left (  ) or right (  ) button. (1 - 120 minutes).

### 4. Digital timer error code

If there is a problem in the engine coolant heater, the digital switch will display an error code. Call the nearest service center and inform the center of the error code.

Error Code (Digital Timer)	Description
F 00	Control unit error
F 01	Failure to operate (after 2 successive trial for starting)
F 02	Ignition failure (3 or more failures)
F 03	Over or under current
F 04	Early flame detected
F 05	Combustion monitor broken or short-circuited
F 06	Temperature sensor line broken or short-circuited
F 07	Fuel pump line broken or short-circuited
F 08	Fan motor line broken, short-circuited, overloaded, or blocked
F 09	Ignition plug line broken or short-circuited
F 10	Overheated
F 11	Circulation pump line broken or short-circuited

5. On rough, frozen, or uneven terrain, travel slowly.



## WARNING

### AVOID DEATH OR SERIOUS INJURY

When traveling, keep bucket (attachment) raised from 20 - 30 cm (8 - 12 in) above the ground. Fasten your seat belt.

Operator should pay attention when traveling backward on a slope.

Never turn or travel across a slope.

Travel straight up or down the slope.

Choose a safe alternate route before climbing a slope.

If excavator starts to slip or becomes unstable, lower the bucket immediately into the ground, using it as a brake.

Avoid working on slopes, because there is a risk of rollover while swinging and performing front attachment operations.

Do not swing towards bottom of slope with a loaded bucket.

In unavoidable cases level the slope with fill soil to make the vehicle as horizontal as possible. See Figure 37.

Do not travel on slopes more than 30° because of risk of rollover.

6. Travel straight up or down slopes, never diagonally across the slope. See Figure 38 and Figure 39. Extend the arm and lower the boom to keep the bucket about 20 - 30 cm (8 - 12 in) off the ground. If the machine starts to slide or becomes unstable, lower the bucket to regain control. If the engine stalls, lower the bucket, make sure that all controls are in the "NEUTRAL" position and restart the engine.

**NOTE:** Even though engine stops on a slope, do not operate swing control. The hydraulic accumulators can cause the unit to swing.

**NOTE:** Do not open or close operator's door on a slope. Make sure door is latched.

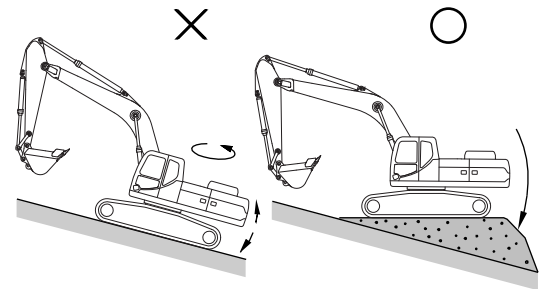

FG018391

Figure 37

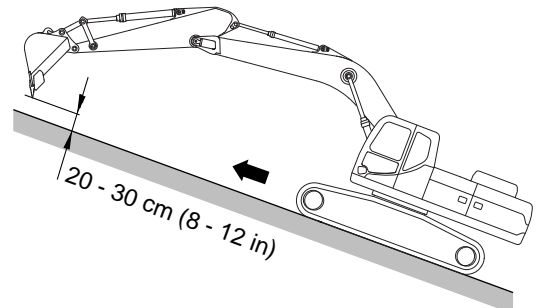

FG018392

Figure 38

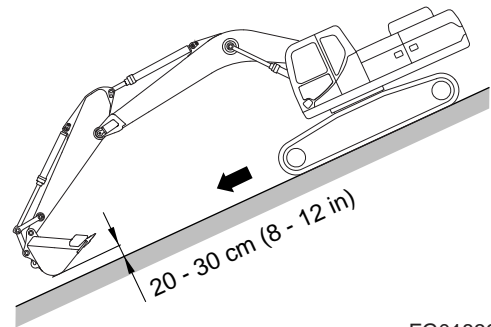

FG018393

Figure 39

### DPF Cleaning (Removing Ash in DPF)

Regeneration of soot collected in the DPF leads to the accumulation of ash in the DPF, which in turn results in reduced engine performance and reduced fuel efficiency because of the increase of back pressure. Periodic ash cleaning is necessary to prevent this. The DPF assembly must be removed for cleaning. The frequency of ash cleaning depends upon the operating conditions, environment, and engine oil used. The first cleaning is recommended to be done after the first 4,500 hours of operation and every 3,000 hours after the first check.

Contact your DOOSAN distributor for DPF cleaning.

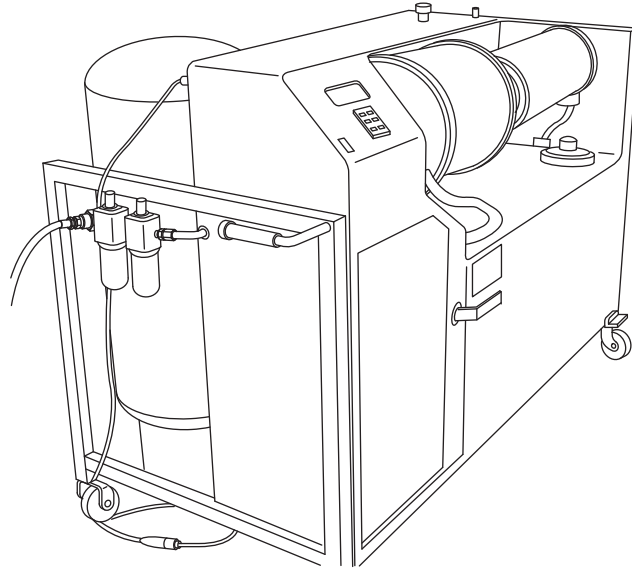

FG018403

**Figure 54** DPF Ash Cleaning Equipment

**NOTE:** When the Intelligent Floating Boom selector switch is in "O" (NORMAL MODE) position, the Intelligent Floating Boom will not operate.

3. Temporary Reset Button

If the intelligent floating boom temporary reset button on the joystick is pressed, additional downward force can be exerted when lowering the boom during Intelligent Floating Boom operation.

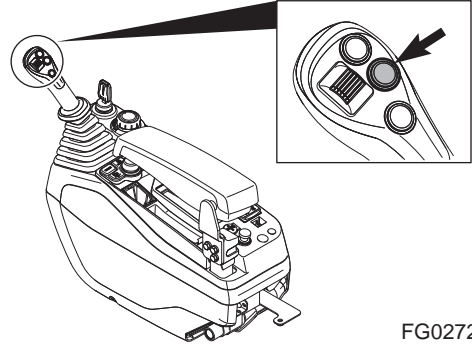

Figure 76

FG027214

CLICK HERE TO **DOWNLOAD** THE COMPLETE MANUAL

- Thank you very much for reading the preview of the manual.
- You can download the complete manual from: [www.heydownloads.com](http://www.heydownloads.com) by clicking the link below



- Please note: If there is no response to CLICKING the link, please download this PDF first and then click on it.

CLICK HERE TO **DOWNLOAD** THE COMPLETE MANUAL

# ATTACHMENTS

## Bucket Replacement and Reversal

---

### IMPORTANT

---

Mounting in reverse direction can result in interference during operation, and is not recommended.

---



### WARNING

---

#### AVOID DEATH OR SERIOUS INJURY

When pins are knocked in with a hammer, pieces of metal may fly and cause serious injury.

When performing this operation, always wear goggles, hard hat, gloves, and other protective equipment.

When the bucket is removed, place it in a stable condition.

If pins are struck with a hammer, there is a potential hazard that they can fly out and injure a bystander. Make sure there is no one in the surrounding area before starting the operation.

When removing the pins, do not stand behind the bucket. Do not put your foot under the bucket while standing at the side for the work.

When removing or inserting pins, be careful not to get your fingers caught.

Never insert your fingers into the pinholes when aligning the holes.

---

Stop the machine on a firm and flat surface and do the work. When performing joint work, appoint a lead and follow that person's instructions and signals.

---

## **IMPORTANT**

---

Using the demolition tool to level the work site or push over standing structures can damage the machine or the demolition tool. Use appropriate equipment to do site preparation or maintenance operations.

---

Align the machine with the work area. Operate the hydraulic shear while you travel backward.

---

---

## **IMPORTANT**

---

To avoid structural damage to the machine, do not break road surfaces by placing the cutting edge of the hydraulic shear on the ground and moving the machine.

---

To peel and remove road surface with the hydraulic shear, place the cutting edge of the stationary jaw between the road surface and the road bed. Use the work tool cylinder to separate the road surface and the road bed.

---

---

## **IMPORTANT**

---

Operating the demolition tool with the cylinders fully retracted or fully extended could cause structural damage to the machine.

---

---

## **IMPORTANT**

---

Using the machine hydraulic cylinder or the demolition tool rotating device to aid in the breaking or shearing process can damage the machine or the demolition tool rotating device. Use only the arm hydraulic cylinders to perform demolition operations.

---

---

## **IMPORTANT**

---

Hitting the demolition tool against the ground or solid object to dislodge an obstruction or free the cutting arm can damage the demolition tool or the machine. Use a pry bar or cutting torch to free the cutting arm or dislodge the obstruction.

Always check the cutting edge alignment after the jaws are working properly.

---

4. Lubricate and perform services outlined on current lubrication chart on machine and Lubrication Chart and Table. Section 4. Clean all lubrication fittings before applying lubricant. Sand mixed with lubricant becomes very abrasive and accelerates wear on parts.
5. Protect machine from dust and sand as much as possible. Park machine under cover to keep dust and sand from damaging unit.

## Operation in Rainy or Humid Conditions

Operation under rainy or humid conditions is similar to that as in extreme heat procedures previously listed.

1. Keep all exposed surfaces coated with preservative lubricating oil. Pay particular attention to damaged or unpainted surfaces. Cover all paint cracks and chip marks as soon as possible to prevent corrosive effects.

## Operation in Saltwater Areas

Saltwater and saltwater spray is very corrosive. When operating in or around saltwater areas, or in or around snow, observe the following precautions:

1. When exposed to saltwater, dry machine thoroughly and rinse with freshwater as soon as possible.
2. Keep all exposed surfaces coated with preservative lubricating oil. Pay attention to damaged paint surfaces.
3. Keep all painted surfaces in good repair.
4. Lubricate machine as prescribed on lubrication chart on machine or Periodic Service Table and Chart, Section 4, in this manual. Shorten lubricating intervals for parts exposed to salt water.
5. Check operating controls to ensure proper functionality and that they return to "NEUTRAL" when released.

## Operation at High Altitudes

Operation instructions at high altitudes are the same as those provided for extreme cold. Before operating at high altitudes, engine fuel and air mixture may have to be adjusted according to appropriate engine manual.

1. Check engine operating temperature for evidence of overheating. The radiator cap must make a perfect seal to maintain coolant pressure in cooling system.
  - Perform warming-up operation thoroughly. If machine is not thoroughly warmed up before control levers or control pedals are operated, reaction of machine will be slow.

# MACHINE SETUP POSITION FOR MAINTENANCE

Before beginning any service work, park the machine using the following procedure (except for service work requiring the machine to be positioned differently).

1. Position the machine on even, firm and level ground.
2. Put attachment on ground.

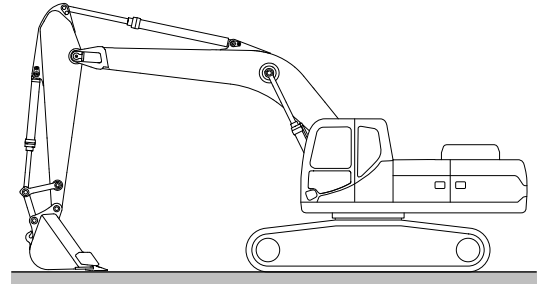

FG018379

Figure 1

3. Move safety lever to "LOCK" position.

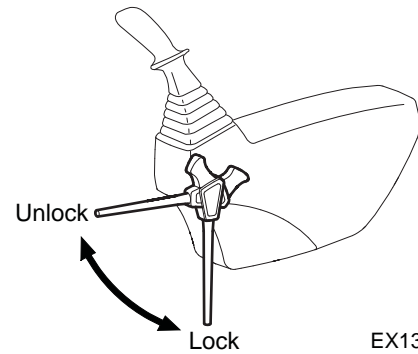

EX1300566

Figure 2

4. Allow engine to run at "LOW IDLE" for a minimum of five minutes to allow engine to cool. If this is not done, heat surge can occur.

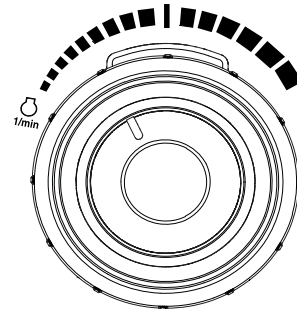















FG018148

Figure 3

## Symbols for "Lubrication and Service Chart"

The lubrication and service chart is on the inside of the battery box cover. The symbols used in the lubrication and service chart are illustrated in the following table.

Symbol	Description
	Lubrication
	Gear Oil (Swing Device, Travel Device)
	Engine Oil
	Engine Oil Filter
	Hydraulic Oil
	Hydraulic Oil Filter
	Hydraulic Oil Tank Breather

Symbol	Description
	Coolant
	Air Cleaner Filter
	Fuel Filter
	Air Conditioner Filter
	Drain Water
	Fuel Cap Filter
	Diesel Particulate Filter

## Check Level of Hydraulic Oil Tank



### WARNING

#### AVOID DEATH OR SERIOUS INJURY

The hydraulic oil will be hot after machine operation. Allow system to cool before attempting to service any hydraulic components.

The hydraulic tank is pressurized. Tip breather cap up slowly to allow the pressurized air to vent. After the pressure has been released, remove service covers.

1. Park machine on firm and level ground. Lower boom and position bucket on ground as shown in Figure 15.
2. Move engine speed to "LOW IDLE".

3. Move safety lever to "LOCK" position.
4. With one person in the cabin, have a second person, check hydraulic oil level gauge by opening right access door. Oil level must be between marks on sight gauge.

5. If the level is below "L" mark add oil.
  - A. Stop engine.
  - B. The hydraulic tank is pressurized. Tip breather cap up slowly to allow the pressurized air to vent.
  - C. Remove upper cover of the hydraulic tank and add oil.

### IMPORTANT

Do not fill above "H" mark on sight gauge. Overfilling can result in damage to equipment and oil leaking from hydraulic tank because of expansion.



ARO1760L

Figure 14

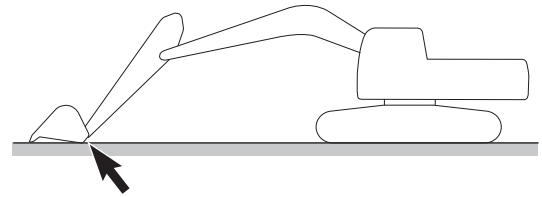

EX1300541

Figure 15



FG020182

Figure 16

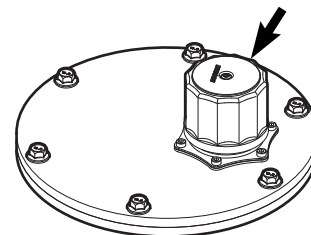

FG020183

Figure 17

**NOTE:** *Hydraulic system must be warmed up to operating temperatures.*

4. Raise the boom and arm so the bucket (or other attachment) is about 1 m (3 ft.) off the ground.
5. Move the safety lever down into "LOCK" position to deactivate the work group and travel functions. Move the work group (joystick) levers. There must be no movement of the boom, arm, and attachment or swing functions when the controls are moved.
6. With the safety lever still in the "LOCK" position, move the travel controls. There must be no movement of the excavator tracks.
7. Move safety lever up into "UNLOCK" position. Raise the boom so the bucket (or other attachment) is about 3 m (10 ft.) off the ground. Operate the work group (joystick) lever to lower the boom slowly. While boom is lowering, move the safety lever down into "LOCK" position. Boom movement must stop. Repeat these steps for arm, bucket (attachment), swing and travel functions.
8. Lower work group to the ground and stop engine.

**NOTE:** *If the PILOT CUTOFF SWITCH (safety lever) does not deactivate the work group and travel functions as described above or if any parts are damaged, bent or missing, contact your DOOSAN distributor immediately for service. DO NOT MODIFY THE SYSTEM.*

## **Check Operation of All Exterior Lights, Horn and Control Console Indicator and Display Monitor**

1. Turn engine starter switch to "I" (ON) position and observe all the indicator lights.
2. Restore operation of any light bulbs that do not turn "ON" now.
3. Sound the horn. Repair or replace if required.
4. Turn "ON" and inspect all exterior work lights. Replace any monitors, burned-out bulbs or cracked or broken housings or lenses.

## **Start Engine, Check Starting Ability, and Observe Exhaust Color at Start-up and at Normal Operating Temperature. Listen for Any Abnormal Sounds.**

## Clean Oil Bath Precleaner (Optional)

The lower parts of the body assembly must be inspected each time the air cleaner is serviced. If there is any sign of buildup or plugging, the body assembly must be removed and cleaned.

At least once a year, remove body assembly and perform the following service steps:

1. Remove oil cups (3 and 4, Figure 51) and removable filter (2).
2. Clean the inner oil cup (3, Figure 51) and outer oil cup (4).
3. Reassemble inner cup in outer cup and refill both cups to indicated oil level (9.5 liters). The same oil specified for the engine crankcase is generally acceptable.

Reference Number	Description
1	Precleaner Housing
2	Screen Filter
3	Inner Oil Cup
4	Outer Oil Cup

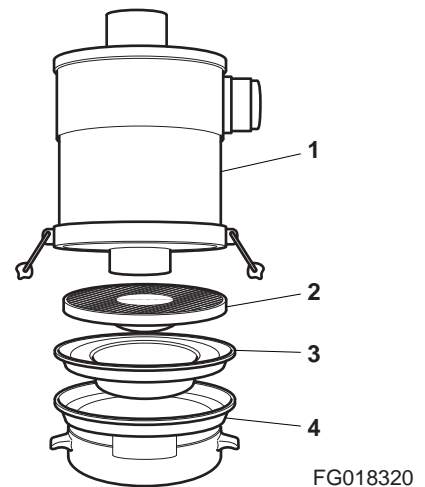

Figure 51

4. Inspect filter with a light. Hold it up to a bright light. An even, bright pattern of light should show through the wire element, meaning it is clean.

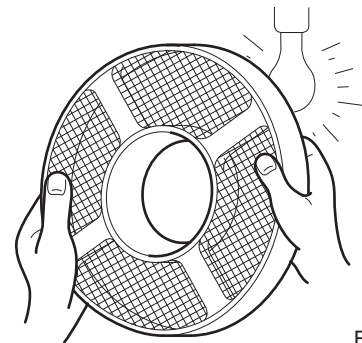

Figure 52

5. Wash filter if needed.
  - If element is plugged with dirt, lint or chaff (even partially), wash it thoroughly with solvent.

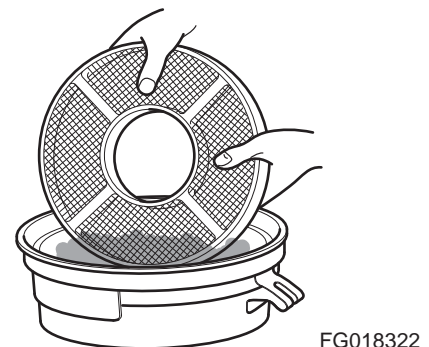

Figure 53

## Change of Fuel Prefilter

1. Open the pump compartment door to access fuel prefilter.

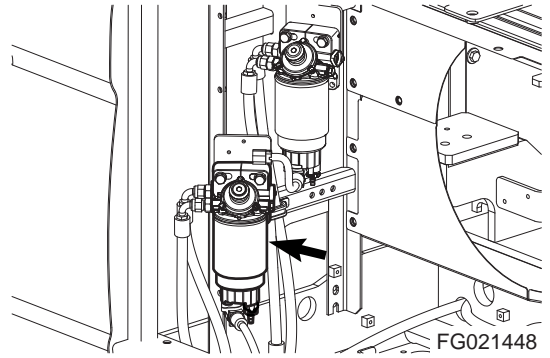

Figure 73

2. Close fuel drain valve (Figure 74).

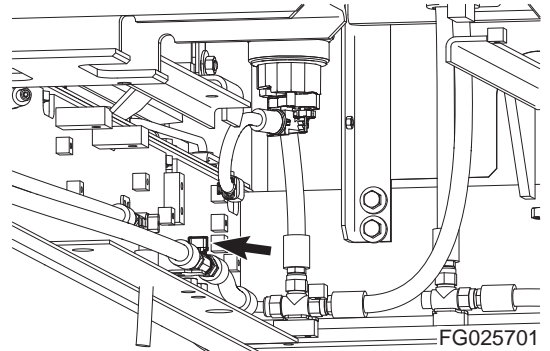

Figure 74

3. Position a small container under fuel prefilter. Drain fuel by opening drain valve (2, Figure 75) on bottom of bowl (1).

**NOTE:** *Dispose of drained fluids in compliance with all applicable environmental laws and regulations.*

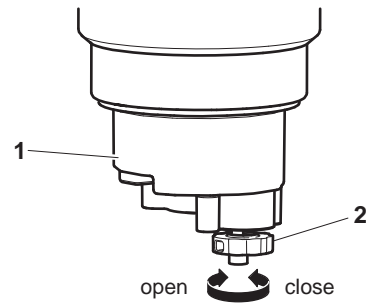

Figure 75

4. Remove bowl using supplied tool.
5. Remove cartridge.

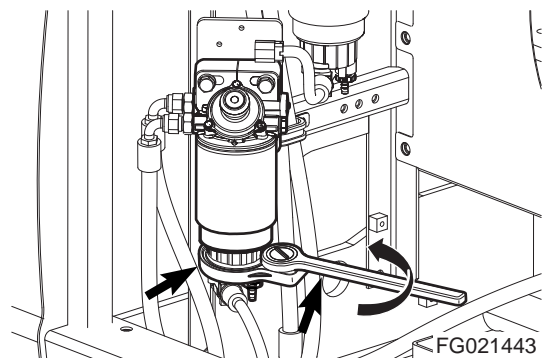

Figure 76

## Change Fuel Cap Filter

---

# IMPORTANT

---

External shock or damage to fuel cap can cause permanent damage to filter.

---

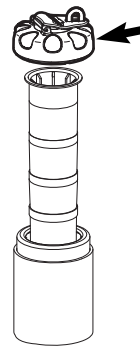

FG020189

Figure 99

1. Remove screws and filter assembly from fuel cap (Figure 100).

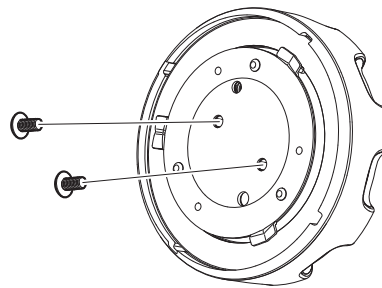

FG015684

Figure 100

2. After disassembly, carefully lay it as shown in Figure 101.

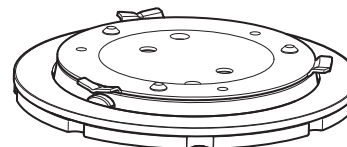

FG015685

Figure 101

3. After disassembly (Figure 101), remove rubber piece as shown on (Figure 102).

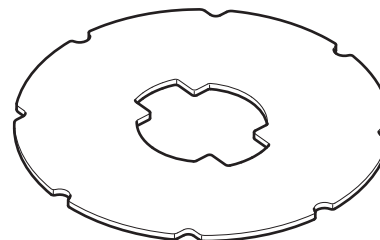

FG015686

Figure 102

# 4,500 HOUR / BIENNIAL SERVICE

## Clean Diesel Particulate Filter (DPF)

---

### **IMPORTANT**

---

Regular ash cleaning is necessary to prevent engine performance and fuel efficiency from deteriorating.

---

### **IMPORTANT**

---

When DPF cleaning is needed, contact DOOSAN distributor for more information.

---

For details, See “DPF Cleaning (Removing Ash in DPF)” on page 3-31.

20. Breaker filter (Optional)

- Tool: 30 mm (🔧)
- Torque: 27 kg•m (265 Nm, 195 ft lb)

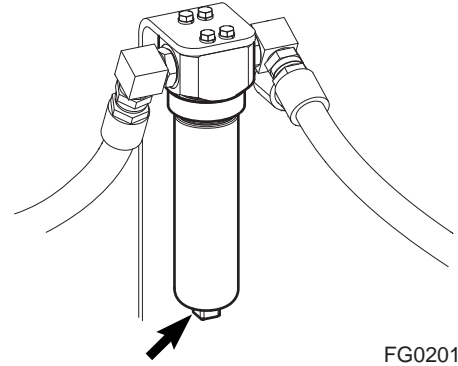

FG020185

Figure 139

21. Grease valve for track adjuster.

- Tool: 27 mm (🔧)
- Torque: 14 kg•m (137 Nm, 101 ft lb)

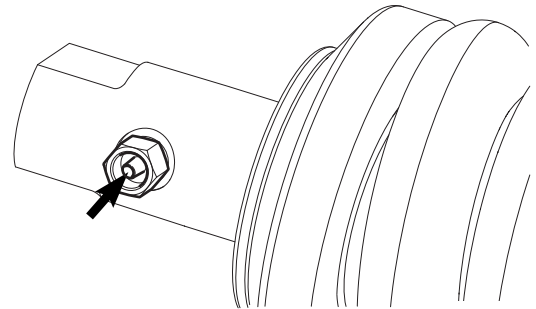

FG018360

Figure 140

22. Mounting bolt for the ROPS.

- Tool: 60 mm (🔧)
  - Torque: 13 kg•m (127.5 Nm, 94.2 ft lb)
- 
- Tool: 19 mm (🔧)
  - Torque: 11.2 kg•m (110 Nm, 81 ft lb)

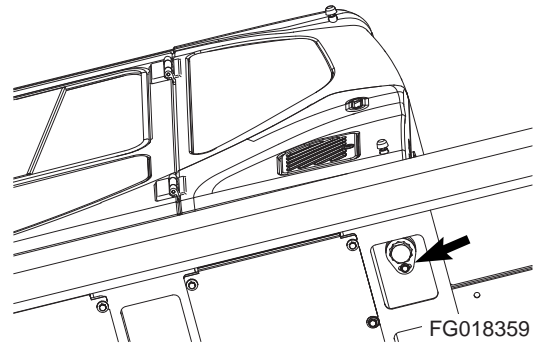

FG018359

Figure 141

23. Mounting bolt for Diesel Particulate Filter (DPF).

- 1) Rubber mounting bolt
  - Tool: 17 mm (🔧)
  - Torque: 6.5 kg•m (64 Nm, 47 ft lb)
- 2) Bracket - Support
  - Tool: 19 mm (🔧)
  - Torque: 11 kg•m (108 Nm, 80 ft lb)

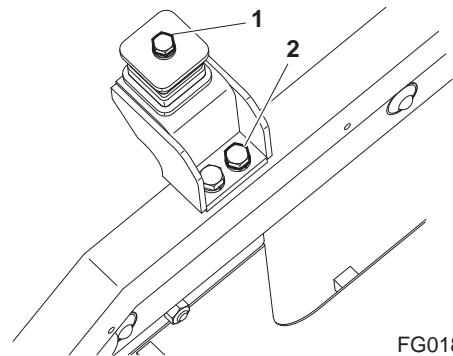

FG018708

Figure 142

# FUEL TRANSFER PUMP (OPTIONAL)

---

## IMPORTANT

---

Dry operating fuel pump for more than fifteen seconds can cause wear and/or damage to pump.

- Cooling and lubrication of pump is achieved by fuel passing through pump. If pump is dry operated, heat generated by moving parts will cause damage to pump rotors, vanes and seals.

Do not operate pump for more than fifteen minutes at a time.

- Continuous usage of pump over recommended time interval will cause overheating of motor and will result in motor damage.

Do not use fueling pump for other types of fuel or fluids. (Use only for diesel fuel)

- Do not use fueling pump for other types of fuel which have a low flash point.
- Do not use fueling pump for fuel contaminated with water or high humidity. Moisture in pump mechanism can cause rust and can create pump failure.

Always operate pump using strainer installed on inlet hose. This will prevent any foreign materials from being introduced into pump. Always maintain pump and all of its components in a clean condition.

- If dirt or other foreign materials enter pump, they can become lodged between the rotor and/or vanes and generate heat which can cause pump damage.
- Do not remove strainer or use a strainer with larger mesh to increase flow of fuel.

Be careful not to overfill or spill fuel.

Make sure direction of check valve is in line with flow direction of fuel.

Any pump parts or components that become lost, damaged or inoperable must be immediately replaced.

---

# Transportation

Check federal, state and local laws and regulations regarding weight, width, and length of a load before making preparations for transporting on public roads or highways.

The hauling vehicle, trailer, and load must comply with all applicable laws and regulations.

Check the intended route for road width, overhead clearances, weight restrictions, and traffic control regulations. Special approval or permits may be required.

## LOADING AND UNLOADING

### Warning for Counterweight and Front Attachment Removal



#### WARNING

---

**AVOID DEATH OR SERIOUS INJURY**

**DO NOT** remove machine counterweight, front attachment or any other part. This could cause tipping or rollover resulting in death or serious injury.

Never remove counterweight or front attachment unless the upper structure is in-line with the lower structure.

Never rotate the upper structure once the counterweight or front attachment has been removed.

---

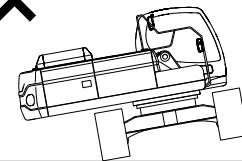
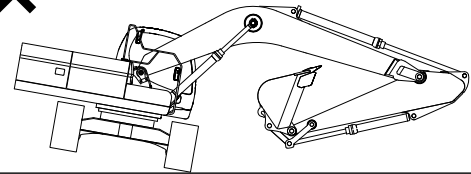

FG018594

Figure 1

# Troubleshooting

Whenever an operating problem with the machine occurs, take corrective action immediately by checking for the cause of the problem.

If the cause of the operating problem cannot be determined, contact your DOOSAN distributor. Never perform an adjustment or the disassembly of the hydraulic, electrical or electronic components without first contacting a DOOSAN distributor.



## WARNING

---

### AVOID DEATH OR SERIOUS INJURY

Instructions are necessary before operating or servicing machine. Read and understand the Operation and Maintenance Manual and signs (decals) on machine. Follow warnings and instructions in the manuals when making repairs, adjustments or servicing. Check for correct function after adjustments, repairs or service. Untrained operators and failure to follow instructions can cause death or serious injury.

---

## ELECTRICAL SYSTEM

Problem	Cause	Correction
Battery will not hold a charge.	Low battery power.	Clean and retighten.
	Alternator belt loose or bad.	Tighten or replace belt.
	Loose or corroded terminals.	Tighten or replace as required.
	Alternator faulty.	Repair or replace as required.
Low battery power.	Internal battery short.	Replace battery.
	Short-circuit in wiring.	Repair as required.
Engine speed is not controllable.	Speed control dial failed.	Replace control dial.
	Throttle controller failed.	Replace controller.
	Speed control motor failed.	Repair or replace as required.
	Blown fuse.	Replace fuse.
	Wiring harness damaged.	Repair or replace as required.
	Connector failed.	Repair or replace as required.

# HYDRAULIC FAN DRIVE SYSTEM











<b>Problem</b>	<b>Cause</b>	<b>Correction</b>
None of the controls function. (Fan does not move or fan operates at only low speed.)	Fan pump failure.	Contact your DOOSAN dealer.
	Fan pump regulator failure.	Contact your DOOSAN dealer/replace the fan pump regulator.
	Controller failure.	Contact your DOOSAN dealer.
	Fan motor failure.	Contact your DOOSAN dealer.
None of the controls function. (Fan operates at only maximum speed.)	Fan pump regulator failure.	Contact your DOOSAN dealer.
	EPPR coil failure.	Contact your DOOSAN dealer/replace the EPPR valve.
	Disconnect the EPPR connector.	Reconnect the EPPR connector.
	Controller failure.	Contact your DOOSAN dealer.
None of the controls function. (Fan operates at higher or lower speed.)	Controller failure.	Contact your DOOSAN dealer.
	Fan pump regulator failure.	Contact your DOOSAN dealer/adjust the fan pump regulator.

# DIGGING FORCE

Description		Unit	7.1 m (23' 4") Boom			6.3 m (20' 8") Boom	
			3.35 m (11' 0") Arm	2.9 m (9' 6") Arm	3.98 m (13' 1") Arm	2.4 m (7' 10") Arm	2.9 m (9' 6") Arm
Bucket Radius		mm (in)	1824.3 (6'0")				
Breakout Force	Normal (SAE)	kN	251.7	251.6	251.7	250.5	251.6
		kg	25,670	25,655	25,670	25,546	25,655
		lb	56,593	56,560	56,593	56,319	56,560
	Power Boost (SAE)	kN	267	266.8	267	265.7	266.8
		kg	27,226	27,210	27,226	27,095	27,210
		lb	60,023	59,988	60,023	59,734	59,988
	Normal (ISO)	kN	284.6	284.4	284.5	283.2	284.4
		kg	29,019	29,001	29,019	28,879	29,001
		lb	63,976	63,936	63,976	63,667	63,936
	Power Boost (ISO)	kN	301.8	301.6	301.8	300.3	301.6
		kg	30,777	30,759	30,777	30,629	30,759
		lb	67,852	67,812	67,852	67,525	67,812
Tearout Force	Normal (SAE)	kN	204.1	231.9	183.3	268.4	231.9
		kg	20,810	23,644	18,695	27,372	23,644
		lb	45,878	52,126	41,215	60,345	52,126
	Power Boost (SAE)	kN	216.4	245.9	194.4	284.7	245.9
		kg	22,071	25,077	19,828	29,031	25,077
		lb	48,658	55,285	43,713	64,002	55,285
	Normal (ISO)	kN	209.5	238.8	187.7	277.2	238.8
		kg	21,366	24,352	19,142	28,265	24,352
		lb	47,104	53,687	42,201	62,314	53,687
	Power Boost (ISO)	kN	222.2	253.3	199.1	294	253.3
		kg	22,661	25,828	20,302	29,978	25,828
		lb	49,959	56,941	44,758	66,090	56,941
Rotation Angle - Bucket		deg	180.8	181.2	181	183	181.2







**FEET**

1,000 lb

A (ft) \ B (ft)	5		10		15		20		25	
										
30										
25										
20									* 23.55	* 23.55
15							* 30.63	* 30.63	* 26.10	25.72
10					* 49.82	* 49.82	* 35.84	34.34	* 29.00	24.52
5					* 52.49	50.25	* 40.14	32.45	* 31.59	23.43
0					* 53.24	48.81	* 42.58	31.26	31.92	22.65
-5	* 29.47	* 29.47	* 37.95	* 37.95	* 57.77	48.50	* 42.95	30.74	31.48	22.24
-10	* 42.80	* 42.80	* 53.90	* 53.90	* 54.07	48.85	* 41.12	30.77	31.46	22.23
-15			* 63.51	* 63.51	* 47.26	* 47.26	* 36.46	31.31	* 28.03	22.71
-20					* 35.29	* 35.29	* 26.31	* 26.31		

**FEET**



1,000 lb

A (ft) \ B (ft)	30		35		MAX. REACH		A (ft)
							
30					15.86	* 15.86	27.91
25	* 20.11	20.02			15.12	* 15.12	31.24
20	* 22.17	19.76			14.92	* 14.92	33.50
15	* 23.46	19.20			15.14	14.83	34.90
10	* 25.06	18.54	* 19.31	14.47	15.74	14.10	35.53
5	24.81	17.91	19.61	14.17	16.80	13.89	35.44
0	24.31	17.44			18.48	14.19	34.62
-5	24.07	17.21			21.02	15.11	33.03
-10	24.21	17.34			23.66	16.97	30.52
-15					24.76	20.67	26.87
-20					23.37	* 23.37	21.41

1. Load point is the end of the arm.
2. Capacities marked with an asterisk (\*) are limited by hydraulic capacities.
3. Lift capacities shown do not exceed 75% of minimum tipping loads or 87% of hydraulic capacities.
4. The least stable position is over the side.
5. The total weight of machine is 47,000 kg (103,617 lb). Included are the; boom 7.1 m (23' 4"), arm 3.98 m (13' 1"), 8,500 kg (18,739 lb) counterweight, bucket weight 0 kg, all operating fluids and a 75 kg (165 lb) operator.
6. Lift capacities are in compliance with ISO 10567.

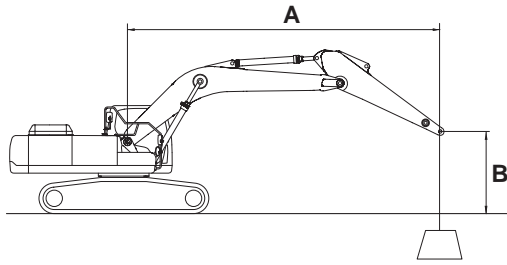
# DX490LC-3













Track Type	: Wide Variable Track
Track Width	: 4.2 m (13' 9")
Boom	: 6.3 m (20' 8")
Arm	: 2.9 m (9' 6")
Bucket	: Without Bucket
Counterweight	: 9,200 kg (20,283 lb)
Shoe	: 900 mm (36")
	: Rating Over Front
	: Rating Over Side or 360 degree
Unit	: 1,000 kg (1,000 lb)

FG022187

**Figure 18**







## METRIC

1,000 kg

A (m) \ B (m)	3		4.5		6		7.5		MAX. REACH		A (m)
											
7.5									* 12.85	* 12.85	6.87
6							* 13.01	* 13.01	* 12.40	11.38	8.20
4.5			* 20.70	* 20.70	* 16.12	* 16.12	* 13.88	12.88	* 12.72	10.17	8.71
3					* 18.32	17.39	* 14.98	12.47	13.05	9.59	8.93
1.5					* 20.01	16.73	* 15.91	12.11	12.96	9.49	8.89
0			* 28.09	25.65	* 20.70	16.37	* 16.29	11.89	13.52	9.86	8.59
-1.5	* 25.40	* 25.40	* 26.70	25.67	* 20.17	16.28	* 15.71	11.85	* 14.40	10.88	7.99
-3	* 31.25	* 31.25	* 23.61	* 23.61	* 18.01	16.46			* 14.65	13.17	7.03
-4.5			* 17.58	* 17.58					* 14.05	* 14.05	5.49

## FEET













1,000 lb

A (ft) \ B (ft)	10		15		20		25		MAX. REACH		A (ft)
											
25									* 27.78	* 27.78	23.87
20							* 28.50	28.41	* 27.34	25.32	26.78
15			* 44.43	* 44.43	* 34.89	* 34.89	* 30.23	27.74	* 27.99	22.51	28.51
10					* 39.63	37.49	* 32.54	26.88	28.80	21.18	29.28
5			* 60.22	55.96	* 43.32	36.06	* 34.51	26.11	28.55	20.92	29.17
0			* 60.93	55.06	* 44.85	35.25	* 35.30	25.63	29.80	21.73	28.17
-5	* 57.30	* 57.30	* 57.95	55.09	* 43.69	35.05	* 33.90	25.56	* 31.76	24.04	26.18
-10	* 67.82	* 67.82	* 51.08	* 51.08	* 38.78	35.47			* 32.30	29.29	22.92
-15			* 37.29	* 37.29					* 30.77	* 30.77	17.69

1. Load point is the end of the arm.
2. Capacities marked with an asterisk (\*) are limited by hydraulic capacities.
3. Lift capacities shown do not exceed 75% of minimum tipping loads or 87% of hydraulic capacities.
4. The least stable position is over the side.
5. The total weight of machine is 49,000 kg (108,026 lb). Included are the; boom 6.3 m (20' 8"), arm 2.9 m (9' 6"), 9,200 kg (20,283 lb) counterweight, bucket weight 0 kg, all operating fluids and a 75 kg (165 lb) operator.
6. Lift capacities are in compliance with ISO 10567.

FEET













1,000 lb

A (ft) \ B (ft)	10		15		20		25		30		MAX. REACH		A (ft)	
														
30												* 25.99	* 25.99	23.79
25							* 25.64	25.25				* 24.38	21.17	27.64
20					* 30.42	* 30.42	* 26.86	24.67	* 25.26	18.24	* 23.90	18.05	30.17	
15					* 35.00	33.08	* 29.10	23.73	* 25.93	17.91	* 24.19	16.33	31.72	
10					* 39.61	31.16	* 31.55	22.73	26.99	17.42	23.95	15.47	32.41	
5					* 42.71	29.81	* 33.48	21.91	26.51	16.98	23.77	15.27	32.32	
0			* 43.94	* 43.94	* 43.64	29.16	34.18	21.41	26.23	16.72	24.59	15.73	31.42	
-5	* 36.99	* 36.99	* 54.85	45.13	* 42.40	29.05	* 33.53	21.28			26.73	17.04	29.65	
-10	* 61.36	* 61.36	* 49.17	45.82	* 38.71	29.41	* 30.19	21.60			* 26.89	19.79	26.82	
-15	* 48.40	* 48.40	* 39.54	* 39.54	* 30.82	30.38					* 25.61	* 25.61	22.54	

1. Load point is the end of the arm.
2. Capacities marked with an asterisk (\*) are limited by hydraulic capacities.
3. Lift capacities shown do not exceed 75% of minimum tipping loads or 87% of hydraulic capacities.
4. The least stable position is over the side.
5. The total weight of machine is 48,800 kg (107,586 lb). Included are the; boom 7.1 m (23' 4"), arm 2.9 m (9' 6"), 9,200 kg (20,283 lb) counterweight, bucket weight 0 kg, all operating fluids and a 75 kg (165 lb) operator.
6. Lift capacities are in compliance with ISO 10567.

**FEET**











1,000 lb

A (ft) \ B (ft)	10		15		20		25		30		MAX. REACH		A (ft)	
														
30								* 19.79	* 19.79			* 19.15	* 19.15	25.11
25								* 23.92	23.07			* 17.99	17.81	28.89
20								* 25.24	22.47	* 23.77	16.54	* 17.62	15.21	31.40
15			* 42.97	* 42.97	* 32.66	30.17	* 27.56	21.51	* 24.71	16.12	* 17.79	13.72	32.95	
10			* 53.16	42.10	* 37.57	28.14	* 30.21	20.44	* 26.05	15.57	* 18.46	12.92	33.70	
5			* 39.95	39.6	* 41.37	26.55	* 32.49	19.51	25.65	15.04	* 19.69	12.66	33.68	
0			* 47.77	38.86	* 43.17	25.65	33.03	18.88	25.24	14.68	* 21.69	12.92	32.90	
-5	* 36.71	* 36.71	* 56.63	38.89	* 42.83	25.34	32.71	18.60	25.12	14.57	23.72	13.81	31.29	
-10	* 57.13	* 57.13	* 51.99	39.40	* 40.22	25.51	* 31.65	18.72			* 25.89	15.69	28.72	
-15	* 56.54	* 56.54	* 44.05	40.42	* 34.37	26.20					* 25.47	19.57	24.89	
-20											* 24.51	* 24.51	18.05	

1. Load point is the end of the arm.
2. Capacities marked with an asterisk (\*) are limited by hydraulic capacities.
3. Lift capacities shown do not exceed 75% of minimum tipping loads or 87% of hydraulic capacities.
4. The least stable position is over the side.
5. The total weight of machine is 47,500 kg (104,720 lb). Included are the; boom 7.1 m (23' 4"), arm 3.35 m (10' 12"), 9,200 kg (20,283 lb) counterweight, bucket weight 0 kg, all operating fluids and a 75 kg (165 lb) operator.
6. Lift capacities are in compliance with ISO 10567.







**FEET**

1,000 lb

A (ft) \ B (ft)	5		10		15		20		25	
										
30										
25										
20									* 23.55	* 23.55
15							* 30.63	* 30.63	* 26.10	* 26.10
10					* 49.82	* 49.82	* 35.84	* 35.84	* 29.00	28.22
5					* 52.49	* 52.49	* 40.14	37.46	* 31.59	27.14
0					* 53.24	* 53.24	* 42.58	36.27	* 33.30	26.35
-5	* 29.47	* 29.47	* 37.95	* 37.95	* 57.77	56.21	* 42.95	35.75	* 33.71	25.94
-10	* 42.80	* 42.80	* 53.90	* 53.90	* 54.07	* 54.07	* 41.12	35.78	* 32.36	25.93
-15			* 63.51	* 63.51	* 47.26	* 47.26	* 36.46	36.32	* 28.03	26.42
-20					* 35.29	* 35.29	* 26.31	* 26.31		

**FEET**













1,000 lb

A (ft) \ B (ft)	30		35		MAX. REACH		A (ft)
							
30					* 15.86	* 15.86	27.91
25	* 20.11	* 20.11			* 15.12	* 15.12	31.24
20	* 22.17	* 22.17			* 14.92	* 14.92	33.50
15	* 23.46	22.14			* 15.14	* 15.14	34.90
10	* 25.06	21.48	* 19.31	16.91	* 15.74	* 15.74	35.53
5	* 26.55	20.85	* 20.25	16.60	* 16.80	16.29	35.44
0	* 27.50	20.38			* 18.48	16.66	34.62
-5	* 27.45	20.16			* 21.14	17.72	33.03
-10	* 25.45	20.29			* 24.65	19.85	30.52
-15					* 24.76	24.05	26.87
-20					* 23.37	* 23.37	21.41

1. Load point is the end of the arm.
2. Capacities marked with an asterisk (\*) are limited by hydraulic capacities.
3. Lift capacities shown do not exceed 75% of minimum tipping loads or 87% of hydraulic capacities.
4. The least stable position is over the side.
5. The total weight of machine is 49,600 kg (109,349 lb). Included are the; boom 7.1 m (23' 4"), arm 3.98 m (13' 1"), 11,100 kg (24,471 lb) counterweight, bucket weight 0 kg, all operating fluids and a 75 kg (165 lb) operator.
6. Lift capacities are in compliance with ISO 10567.

FEET













1,000 lb

A (ft) \ B (ft)	10		15		20		25		30		MAX. REACH		A (ft)	
														
30												* 25.99	* 25.99	23.79
25							* 25.64	* 25.64				* 24.38	* 24.38	27.64
20					* 30.42	* 30.42	* 26.86	* 26.86	* 25.26	22.93	* 23.90	22.70		30.17
15					* 35.00	* 35.00	* 29.10	* 29.10	* 25.93	22.58	* 24.19	20.66		31.72
10					* 39.61	* 39.61	* 31.55	28.76	* 27.06	22.08	* 25.18	19.66		32.41
5					* 42.71	38.25	* 33.48	27.92	* 27.97	21.63	* 26.03	19.48		32.32
0			* 43.94	* 43.94	* 43.64	37.57	* 34.30	27.41	* 28.10	21.37	* 26.50	20.10		31.42
-5	* 36.99	* 36.99	* 54.85	* 54.85	* 42.40	37.46	* 33.53	27.27			* 26.89	21.76		29.65
-10	* 61.36	* 61.36	* 49.17	* 49.17	* 38.71	37.83	* 30.19	27.60			* 26.89	25.22		26.82
-15	* 48.40	* 48.40	* 39.54	* 39.54	* 30.82	30.82					* 25.61	* 25.61		22.54

1. Load point is the end of the arm.
2. Capacities marked with an asterisk (\*) are limited by hydraulic capacities.
3. Lift capacities shown do not exceed 75% of minimum tipping loads or 87% of hydraulic capacities.
4. The least stable position is over the side.
5. The total weight of machine is 51,200 kg (112,877 lb). Included are the; boom 7.1 m (23' 4"), arm 2.9 m (9' 6"), 11,100 kg (24,471 lb) counterweight, bucket weight 0 kg, all operating fluids and a 75 kg (165 lb) operator.
6. Lift capacities are in compliance with ISO 10567.













**METRIC**

1,000 kg

A (m) \ B (m)	12		13.5		15		16.5		18		MAX. REACH		A (m)
													
12					* 3.50	* 3.50					* 2.87	* 2.87	15.41
10.5					* 4.20	* 4.20					* 2.81	* 2.81	16.25
9					* 4.27	* 4.27	* 3.54	* 3.54			* 2.80	* 2.80	16.92
7.5					* 4.42	* 4.42	* 4.33	4.16			* 2.81	* 2.81	17.43
6			* 4.83	* 4.83	* 4.61	* 4.61	* 4.47	4.06			* 2.85	* 2.85	17.79
4.5	* 5.55	* 5.55	* 5.15	* 5.15	* 4.84	4.71	* 4.62	3.94	* 2.99	* 2.99	* 2.92	* 2.92	18.03
3	* 6.02	* 6.02	* 5.49	5.40	* 5.10	4.52	* 4.80	3.81	* 3.37	3.22	* 3.03	* 3.03	18.13
1.5	* 6.48	6.16	* 5.83	5.14	* 5.35	4.34	* 4.98	3.69	* 3.48	3.14	* 3.16	3.10	18.11
0	* 6.91	5.84	* 6.16	4.91	* 5.59	4.17	5.07	3.57			* 3.34	3.08	17.97
-1.5	* 7.28	5.59	* 6.43	4.72	5.73	4.03	4.97	3.48			* 3.58	3.11	17.70
-3	* 7.55	5.39	6.52	4.58	5.62	3.93	4.91	3.41			* 3.88	3.18	17.29
-4.5	7.55	5.27	6.42	4.48	5.56	3.87	4.88	3.39			* 4.29	3.33	16.73
-6	7.49	5.21	6.38	4.44	5.55	3.86					* 4.85	3.55	16.02
-7.5	7.50	5.23	6.41	4.47	5.61	3.92					5.57	3.89	15.11
-9	* 7.25	5.33	* 6.17	4.59							* 5.80	4.40	14.00
-10.5	* 6.48	5.53									* 5.97	5.23	12.60
-12											* 6.06	* 6.06	10.82
-13.5											* 5.88	* 5.88	8.39

**FEET**

1,000 lb

A (ft) \ B (ft)	10		15		20		25		30		MAX. REACH		A (ft)	
														
30												* 25.99	* 25.99	23.79
25							* 25.64	* 25.64				* 24.38	23.41	27.64
20					* 30.42	* 30.42	* 26.86	* 26.86	* 25.26	20.27		* 23.90	20.06	30.17
15					* 35.00	* 35.00	* 29.10	26.27	* 25.93	19.94		* 24.19	18.23	31.72
10					* 39.61	34.56	* 31.55	25.27	* 27.06	19.45		* 25.18	17.31	32.41
5					* 42.71	33.21	* 33.48	24.45	* 27.97	19.00		* 26.03	17.12	32.32
0			* 43.94	* 43.94	* 43.64	32.55	* 34.30	23.95	* 28.10	18.75		* 26.50	17.65	31.42
-5	* 36.99	* 36.99	* 54.85	50.26	* 42.40	32.45	* 33.53	23.82				* 26.89	19.10	29.65
-10	* 61.36	* 61.36	* 49.17	* 49.17	* 38.71	32.81	* 30.19	24.14				* 26.89	22.11	26.82
-15	* 48.40	* 48.40	* 39.54	* 39.54	* 30.82	* 30.82						* 25.61	* 25.61	22.54

1. Load point is the end of the arm.
2. Capacities marked with an asterisk (\*) are limited by hydraulic capacities.
3. Lift capacities shown do not exceed 75% of minimum tipping loads or 87% of hydraulic capacities.
4. The least stable position is over the side.
5. The total weight of machine is 50,700 kg (111,774 lb). Included are the; boom 7.1 m (23' 4"), arm 2.9 m (9' 6"), 11,100 kg (24,471 lb) counterweight, bucket weight 0 kg, all operating fluids and a 75 kg (165 lb) operator.
6. Lift capacities are in compliance with ISO 10567.

CLICK HERE TO **DOWNLOAD** THE COMPLETE MANUAL

- Thank you very much for reading the preview of the manual.
- You can download the complete manual from: [www.heydownloads.com](http://www.heydownloads.com) by clicking the link below



- Please note: If there is no response to CLICKING the link, please download this PDF first and then click on it.

CLICK HERE TO **DOWNLOAD** THE COMPLETE MANUAL