

DX350LC

Operation and Maintenance Manual

K1046035E

Serial Number 5980 and Up

October 2008

DOOSAN reserves the right to improve our products in a continuing process to provide the best possible product to the market place. These improvements can be implemented at any time with no obligation to change materials on previously sold products. It is recommended that consumers periodically contact their distributors for recent documentation on purchased equipment.

This documentation may include attachments and optional equipment that is not available in your machine's package. Please call your distributor for additional items that you may require.

Illustrations used throughout this manual are used only as a representation of the actual piece of equipment, and may vary from the actual item.

CLICK HERE TO **DOWNLOAD** THE COMPLETE MANUAL

- Thank you very much for reading the preview of the manual.
- You can download the complete manual from: www.heydownloads.com by clicking the link below



- Please note: If there is no response to CLICKING the link, please download this PDF first and then click on it.

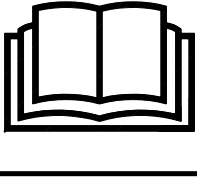

CLICK HERE TO **DOWNLOAD** THE COMPLETE MANUAL

1. Warnings for Operation, Inspection and Maintenance (190-00688, 190-00092)

<p style="text-align: center;">⚠ WARNING</p> <ul style="list-style-type: none"> • AVOID DEATH OR SERIOUS INJURY. - READ AND UNDERSTAND OPERATION MANUAL AND SAFETY LABELS prior to operating this machine. • Never get in under the machine while it is being jacked up with boom and arm. • Sound the horn to alert the people nearby before operating, and make sure that all persons are clear of area. • Controls may be changed for attachments or operator preference. Try control pattern before operating. <p style="text-align: right;">190-00688</p>	  <p style="text-align: right;">190-00092</p>
---	--

ARO1080L

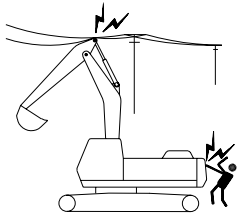
2. Warnings for High Voltage (190-00689, 190-00096)

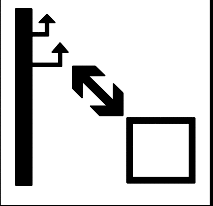
	<p style="text-align: center;">⚠ DANGER</p> <p>SERIOUS INJURY OR DEATH BY ELECTROUTION can occur if machine or attachments are not a safe distance from electrical power lines.</p> <table border="1"> <thead> <tr> <th>Line voltage</th> <th>Safe Distance</th> </tr> </thead> <tbody> <tr> <td>6.6 kv</td> <td>At least 3m(10ft)</td> </tr> <tr> <td>66.6 kv</td> <td>At least 5m(16ft)</td> </tr> <tr> <td>275.0 kv</td> <td>At least 10m(33ft)</td> </tr> </tbody> </table> <p style="text-align: right;">190-00689</p>	Line voltage	Safe Distance	6.6 kv	At least 3m(10ft)	66.6 kv	At least 5m(16ft)	275.0 kv	At least 10m(33ft)	  <p style="text-align: right;">190-00096</p>
Line voltage	Safe Distance									
6.6 kv	At least 3m(10ft)									
66.6 kv	At least 5m(16ft)									
275.0 kv	At least 10m(33ft)									

ARO1090L

UNAUTHORIZED MODIFICATIONS

Any modification made without authorization or written approval from *DOOSAN* can create a safety hazard, for which the machine owner must be held responsible.

For safety's sake, replace all OEM parts with the correct authorized or genuine *DOOSAN* part. For example, not taking the time to replace fasteners, bolts or nuts with the correct replacement parts could lead to a condition in which the safety of critical assemblies is dangerously compromised.

GENERAL HAZARD INFORMATION

Safety Rules

Only trained and authorized personnel can operate and maintain the machine.

Follow all safety rules, precautions and instructions when operating or performing maintenance on the machine.

Do not operate the machine if you are not feeling well, if you are taking medication that makes you feel sleepy, if you have been drinking, or if you are suffering from emotional problems. These problems will interfere with your sense of judgement in emergencies and may cause accidents.

When working with another operator or with a person on work site traffic duty, be sure that all personnel know the nature of the work and understand all hand signals that are to be used.

Always observe strictly any other rules related to safety.

Safety Features

Be sure that all guards and covers are installed in their proper position. Have guards and covers repaired immediately if damaged.

Be sure that you understand the method of use of safety features such as safety lock lever and the seat belt, and use them properly.

Never remove any safety features. Always keep them in good operating condition.

Failure to use safety features according to the instructions in the Operation and Maintenance Manual could result in serious bodily injury.

Checks Before Starting Engine

Every day before starting the engine for the first time, carry out the following checks. If these checks are not carried out properly, there is danger of serious injury.

Completely remove all wood chips, leaves, grass, paper and other flammable materials accumulated in the engine compartment and around the battery. They could cause a fire. Remove any dirt from the window glass, mirrors, handrails, and steps.

Do not leave tools or spare parts laying around in the operator's compartment. The vibration of the machine when traveling or during operations may cause them to fall and damage or break the control levers or switches. They may also get caught in the gap of the control levers and cause the work equipment to malfunction or move dangerously. This may lead to unexpected accidents.

Check the coolant level, fuel level, and hydraulic tank oil level, and check for clogged air cleaner and damage to the electrical wiring.

Adjust the operator's seat to a position where it is easy to operate the machine, and check the seat belt and mounts for damage and wear.

Check the operation of the gauges and the angle of the mirrors, and check that the safety lever is in "LOCKED" position.

If any abnormalities are found in the above checks, carry out repairs immediately.

Engine Starting

Walk around your machine before getting in the operator's cabin. Look for evidence of leaking fluid, loose fasteners, misaligned assemblies or any other indications of possible equipment hazard.

All equipment covers and machinery safety guards must be in place, to protect against injury while the machine is being operated.

Look around the work site area for potential hazards, people or property that could be at risk while operation is in progress.

NEVER start the engine if there is any indication that maintenance or service work is in progress, or if a warning tag is attached to controls in the cabin.

A machine that has not been used recently, or is being operated in extremely cold temperatures, could require a warm-up or maintenance service before start-up.

Check gauges and monitor displays for normal operation before starting the engine. Listen for unusual noises and remain alert for other potentially hazardous conditions at the start of the work cycle.

Do not short circuit the starting motor to start the engine. This is not only dangerous, but may also damage the machine.

When starting the engine, sound the horn as an alert.

Start and operate the machine only while seated.

Proper Tools

Use only tools suited to the task. Using damaged, low quality, faulty, or makeshift tools could cause personal injury. There is danger that pieces from, chisels with crushed heads, or hammers, may get into your eyes and cause blindness.

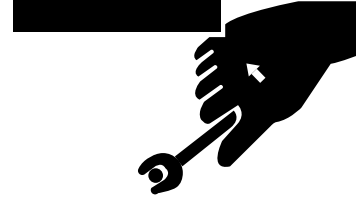

Figure 32

HDO1037L

Use of Lighting

When checking fuel, oil, battery electrolyte, or window washing fluid, always use lighting with antiexplosion specifications. If such lighting equipment is not used, there is danger of an explosion.

If work is carried out in dark places without using lighting, it may lead to injury, so always use proper lighting.

Even if the place is dark, never use a lighter or flame instead of lighting. There is danger of fire. There is also danger that the battery gas may catch fire and cause an explosion.



Figure 33

HDO1040L

Fire Prevention and Explosion Prevention

All fuels, most lubricants and some coolant mixtures are flammable. Leaking fuel or fuel that is spilled onto hot surfaces or onto electrical components can cause a fire.

Store all fuels and all lubricants in properly marked containers and away from all unauthorized persons.

Store oily rags and other flammable material in a protective container.

Do not smoke while you refuel the machine or while you are in a refueling area.

Do not smoke in battery charging areas or in areas that contain flammable material.

Clean all electrical connections and tighten all electrical connections. Check the electrical wires daily for wires that are loose or frayed. Tighten all loose electrical wires before you operate the machine. Repair all frayed electrical wires before you operate the machine.

Remove all flammable materials before they accumulate on the machine.

Do not weld on pipes or on tubes that contain flammable fluids. Do not flame cut on pipes or on tubes that contain flammable fluids. Before you weld on pipes or on tubes or before you flame cut on pipes or on tubes, clean the pipes or tubes thoroughly with a nonflammable solvent.



Figure 34

HDO1015I

TOWING

Precautions When Towing

If any mistake is made in the method of selecting or inspecting the towing wire or in the method of towing, it may lead to serious personal injury. Always do the following;

- Always use the method of towing given in this Operation and Maintenance Manual. Do not use any other method.
- Use leather gloves when handling the wire rope.
- When carrying out the preparation work for towing with two or more workers, determine the signals to use and follow these signals correctly.
- Always fit the towing rope to the left and right hooks and secure in position.
- If the engine on the problem machine will not start or there is a failure in the brake system. always contact your *DOOSAN* distributor.
- Never go between the towing machine and the towed machine during the towing operation.
- It is dangerous to carry out towing on slopes, so select a place where the slope is gradual. If there is no place where the slope is gradual, carry out operations to reduce the angle of the slope before starting the towing operation.
- When towing a problem machine, always use a wire rope with a sufficient towing capacity.
- Do not use a frayed, kinked rope or a rope with any loss of diameter.
- Do not use the lightweight towing hook for towing another machine.

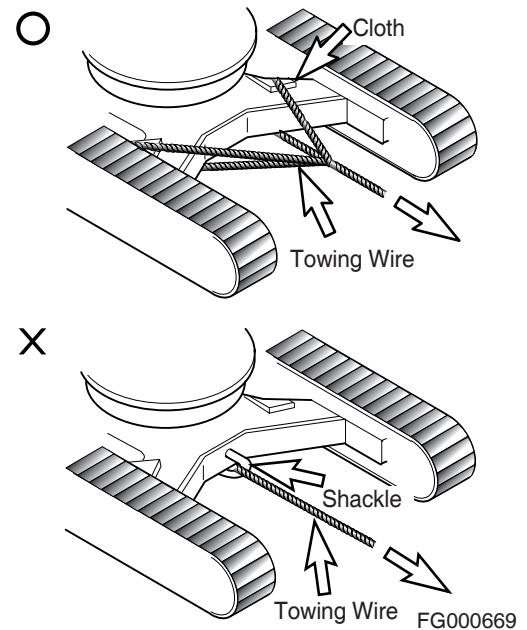

Figure 47

Reference Number	Description
1	Counterweight
2	Hood
3	Muffler
4	Hydraulic Oil Tank
5	Fuel Tank
6	Engine
7	Fuel Tank Fill Cap
8	Radiator and Oil Cooler
9	Control Valves
10	Swing Motor
11	Precleaner
12	Air Cleaner
13	Swing Bearing
14	Cabin
15	Seat
16	Boom Cylinder
17	Work Lever (Joystick) Controls
18	Arm Cylinder
19	Boom
20	Travel Lever

Reference Number	Description
21	Arm
22	Bucket Cylinder
23	Guide Link
24	Bucket
25	Push Link
26	Tooth Point
27	Side Cutter
28	Idler
29	Track Adjuster
30	Track Guide
31	Battery
32	Lower Roller
33	Center Joint
34	Upper Roller
35	Sprocket
36	Travel Motor
37	Track Link and Shoe
38	Suction Filter
39	Return Filter
40	Pumps

12. Lower Wiper Switch (Optional)

This switch is used to control the lower front window wiper.

- O. In this position, lower windshield wiper is "OFF."
- I. In this position, lower windshield wiper runs at a constant speed.

NOTE: *Operating wiper without washer fluid or when there is sand or dirt present will damage the window and wiper.*

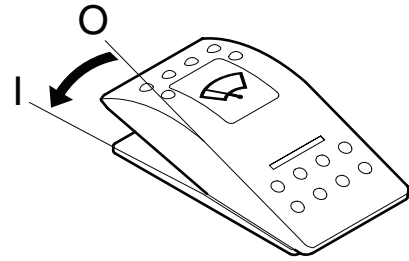

FG000028

Figure 19

13. Heater and Air Conditioner Control Panel

This panel is used to control air conditioner and heater in operator's compartment. Refer to "Heater and Air Conditioner Control Panel" on page 2-49 for more details.

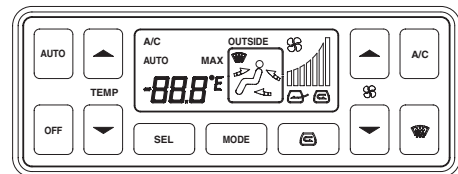

FG000029

Figure 20

14. Wiper Switch Panel

This panel is only for operation of the upper windshield wiper. When the wiper stops running, it moves to right side of the cabin, resting in its support.

NOTE: *When the front window is lifted, the wiper motor will not operate.*

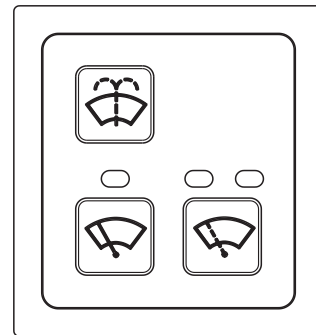

FG000308

Figure 21

3. Hydraulic Oil Temperature Gauge

The colored bands indicate the temperature of the hydraulic oil

WHITE ZONE (□) - Indicates temperature is lower than the normal operating temperature.

BLUE ZONE (■) - Indicates temperature is within the normal operating range.

RED ZONE (■) - Indicates temperature is too high.

During operation, the pointer must be in the blue zone.

If the gauge pointer moves into the red zone, the hydraulic oil temperature symbol will turn "ON," and be display in the screen. Allow the engine to run at low idle speed until the temperature gauge registers in the blue zone again.

NOTE: See "Abnormal State Warning Symbols" on page 2-29, for location of this warning symbol and others.

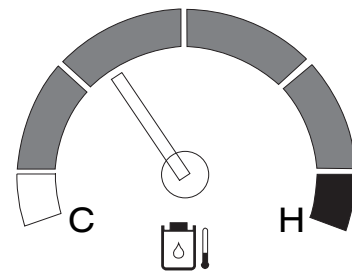

FG013673

Figure 41

4. Multifunction Gauge and Graphic Information Area

See "Multifunction Gauge and Graphic Information" on page 2-27. This section will have a more in-depth explanation of the display area.

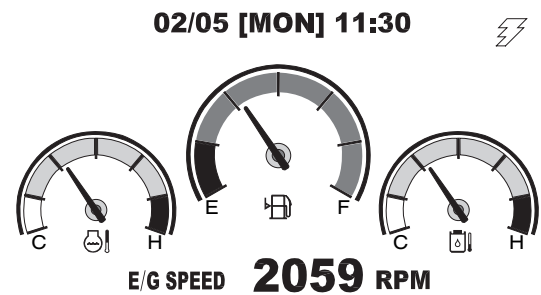

FG013591

Figure 42

5. Digital Clock

A digital clock, shows the current time. The displayed contents are as follows.

Display	Description
MM	Month
DD	Date
W	Day
HH	Hour
mm	Minute
A (P)	AM (PM)

Refer to the "Setting Main Menu" on page 2-35 for time setting.

MM/DD [W] HH:mm

FG000044

Figure 43

MODE SELECTOR BUTTONS

1. Power Mode Selector Button
2. Economy Mode Selector Button
3. Auto Idle Selector Button
4. Flow Control Button



FG013707

Figure 67

1. Power Mode Selector Button

This power mode is suitable for heavy-duty work that requires a high operating speed. Push this button to turn power mode "ON" or "OFF."

When the power mode button is pushed to the "ON" position, an indicator light above it turns "ON."

When the power mode button is pushed again, it is turned "OFF" and the power mode is deactivated and returns to the standard operating mode.

When turning the engine starter switch to the "I" (ON) position, the power mode is automatically defaulted to "Standard Mode."

NOTE: For further details, see "Mode Selection" on page 3-20.



FG013709

Figure 68

2. Economy Mode Selector Button

Economy mode is used for light loading work, when this mode selected it will reduce noise and fuel consumption with standard mode.

When the economy mode button is pushed to the "ON" position, a symbol appears on the screen.

NOTE: When the economy mode button is pushed again, it is turned "OFF" and the economy mode is deactivated and returns to the standard operating mode.



FG013710

Figure 69

Press "ESC" () button (3,Figure 73) for 1 more second, it returns to main menu.

According to the selection of adoption (lock) or nonadoption (unlock), the password function will be in working or nonworking.

When you want to change a password, follow below procedure.

1. Move the cursor to "Change Password."
2. Input desired 4 digits password using selector buttons (at the first column). Input the same password one more time (at the second column)
3. Select adoption (lock) or nonadoption (unlock) at set password menu.

NOTE: *Keep in mind never to forget password.*

NOTE: *Please contact a DOOSAN distributor, if you forget your password.*

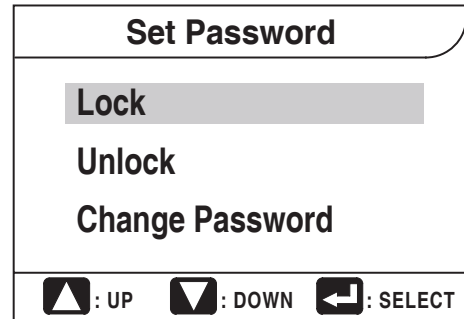

FG013718

Figure 96

- D. Used to direct air flow to the front window and to operator's feet.

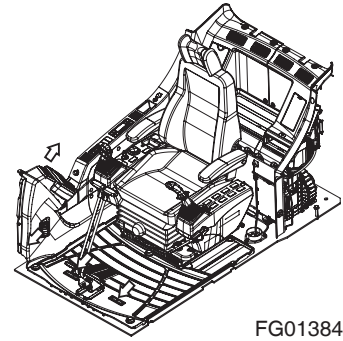

FG013841

Figure 122

6. Air Inlet Selector Button

This button is used to select fresh air from outside the cabin, or recirculate air within the cabin.

Pressing this switch enables the choice between fresh air and recirculating air within the operator's compartment. The select mode is displayed on the LCD.

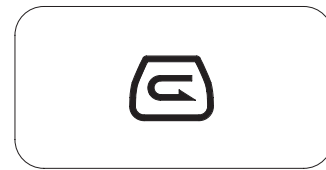

FG000101

Figure 123

- A. "A" Symbol - Draws fresh air into operator's compartment. Used to exchange air within the operator's compartment with fresh air. Used to remove condensation or ice on window (Winter / Rainy Season).
- B. "B" Symbol - Recirculates air within the operator's compartment. Used to quickly warm or cool the operator's cabin.

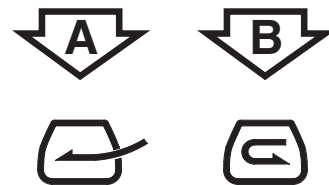

FG000102

Figure 124

7. Fan Speed Selector Buttons

These buttons are used to control the speed of the blower fan.

Momentarily, pressing a button, changes the speed one stage.

Continuously pressing and holding a button, repeatedly changes the speed.

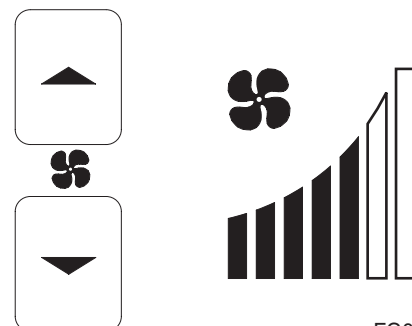

FG000103

Figure 125

FRONT WINDOWS



When leaving operator's seat, set the safety lever to "LOCK" position (Figure 145), if not a serious accident could occur by accidentally moving the work levers.

Front Upper Window

The front upper window can be housed in the cabin's ceiling.

Opening the Window



When stowing front window in the cabin roof, make sure both release levers (1, Figure 146) are latched.

1. Lower bucket to ground.
2. Set safety lever (Figure 145) on "LOCK."
3. Set engine speed control dial to "LOW IDLE." Allow engine to idle for three - five minutes.
4. Shut down engine by turning key to "O" (OFF) position.
5. Hold the window handles (1, Figure 146), then pull the lock levers (2) to release the lock. The top of the front window will come out.
6. Pull window up, and push it against lock pin at the rear of the cabin. Make sure that it is securely latched.
7. Check that lock levers are securely latched in the lock position.

NOTE: When the front upper window is open, never extend your head or body through the window frame.

NOTE: If the window happens to fall with a strong impact against the machine, while some part of your body is extended out of the cabin, it may result in bodily injury.

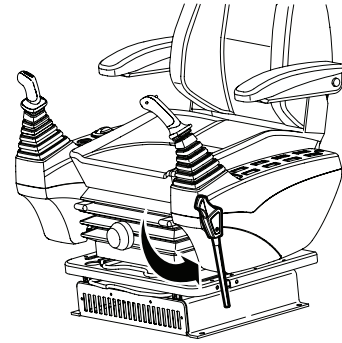

FG000189

Figure 145

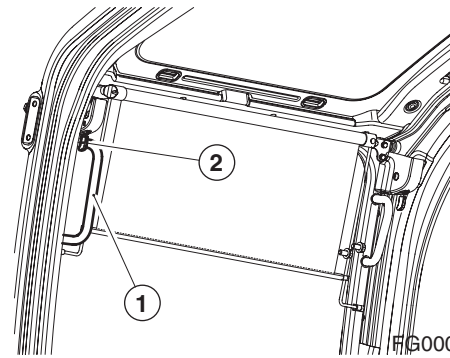

FG000192

Figure 146

Operational Checks Before Starting Engine

WARNING

When leaving operator's seat, set the safety lever to "LOCK" (Figure 1) position, if not a serious accident could occur by accidentally moving the travel or work levers.

1. Set safety lever on "LOCK" (Figure 1).
2. Fasten seat belt. Check for proper operation and condition.
3. Set all operation levers in "NEUTRAL."

NOTE: *Be careful not to touch any switches when starting engine.*

4. Rotate the starter switch to the "I" (ON) position (Figure 2). Check all indicator lights. A warning buzzer will sound for about two seconds. After two seconds, all lights except the following will turn "OFF."

- Charging warning light
- Engine oil pressure warning light
- Engine coolant temperature gauge
- Fuel gauge
- Hydraulic oil temperature gauge
- Engine rpm (0 rpm) digital readout

NOTE: *If all of the indicator lights do not come "ON" when the key is first turned, there is a problem.*

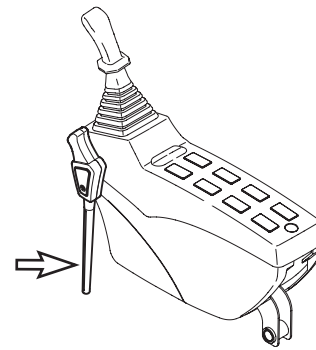

FG000211

Figure 1

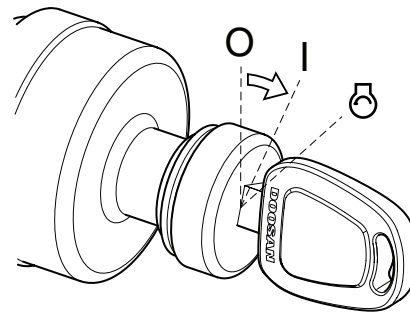

FG000084

Figure 2

CLICK HERE TO **DOWNLOAD** THE COMPLETE MANUAL

- Thank you very much for reading the preview of the manual.
- You can download the complete manual from: www.heydownloads.com by clicking the link below



- Please note: If there is no response to CLICKING the link, please download this PDF first and then click on it.

CLICK HERE TO **DOWNLOAD** THE COMPLETE MANUAL

Engine Shut Down

NOTE: Allow engine to idle for three - five minutes before shutting down the engine. If not allowed to idle, heat surge may develop which will damage the engine. Allowing the engine to idle will dissipate heat.

1. Park excavator on level and firm ground.
2. Lower front end attachment to ground and make sure all operating controls are in "NEUTRAL."
3. Set safety lever on "LOCK" position (Figure 22).

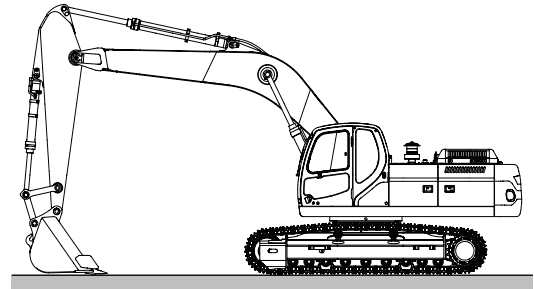

FG000111

Figure 21

3. Set safety lever on "LOCK" position (Figure 22).

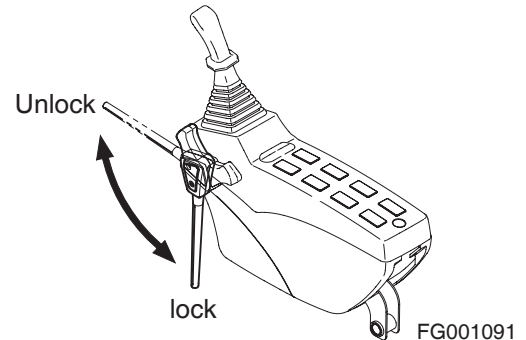

FG001091

Figure 22

4. Set engine speed control dial to "LOW IDLE" (Figure 23). Allow engine to idle for three - five minutes.

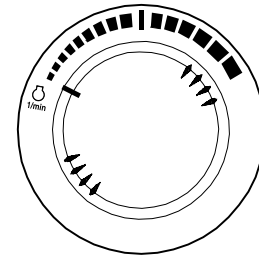

HAOB290L

Figure 23

5. Shut down engine by turning key to "O" (OFF) position (Figure 24).
6. Remove key from starter switch.

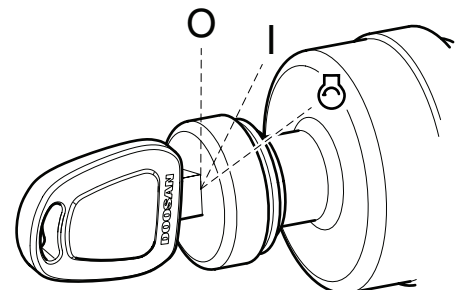

FG000175

Figure 24

Change Machine Control Pattern by Select Valve (If Equipped)



Check surrounding area before swinging. When operating a lever while in auto idle, do it carefully, because the engine speed will increase rapidly.

NOTE: When starting work, move work levers (joysticks) slowly and check movement of swing and front attachment.

The machine control pattern can easily be changed to the ISO standard or to the BHL standard by changing the position of the select valve (if equipped). Use the following procedure to change the position of the select valve.

The select valve is located in the rear of the cabin.

1. Rotating spool to the ISO position or to the BHL position. (Figure 48)

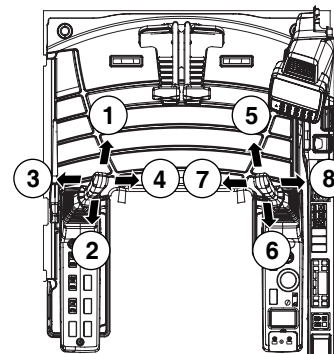

FG013842

Figure 47

<ISO PATTERN>

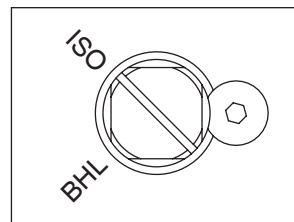

<BHL PATTERN>

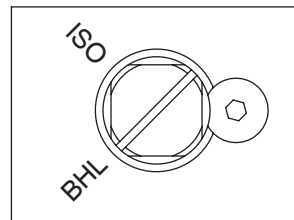

FG004954

Figure 48

Hydraulic Breaker Operation

NOTE: Hydraulic pressure and flow settings may need to be changed. Refer to the Maintenance Section of this manual for further information.

1. Make sure to read and understand the breaker user's manual.
2. Inspect all mechanical and hydraulic connections.
3. Do not use the breaker as a hammer. See Figure 71.

Do not drop breaker from extreme heights.

The breaker is relatively heavy and drops fast. Do not drop breaker from extreme heights or damage to upper structure may result.

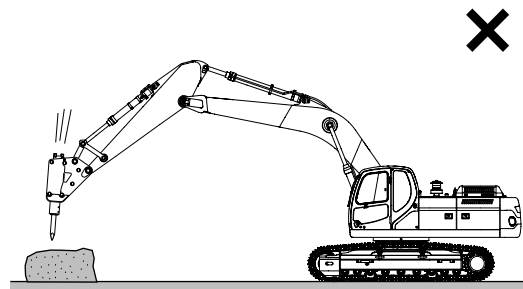

FG000188

Figure 71

4. Do not operate the breaker with the boom or arm cylinders fully extended (bottomed out). See Figure 72.

Leave over 100 mm (4 in) of clearance between rod end of cylinder and cylinder head. This will help prevent damage to cylinders during breaker operation.

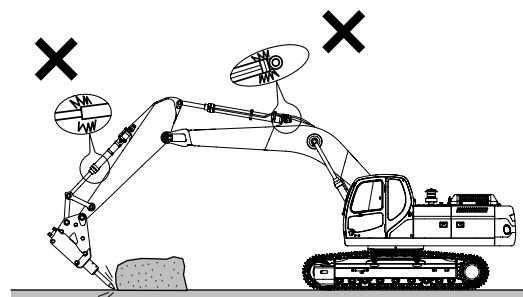

FG000191

Figure 72

5. Do not use the breaker if the hydraulic hoses vibrate excessively. See Figure 73. Check the breaker's hydraulic accumulator (1) for damage and repair as required. If excavator is operated under this condition, structural and hydraulic components can be damaged.

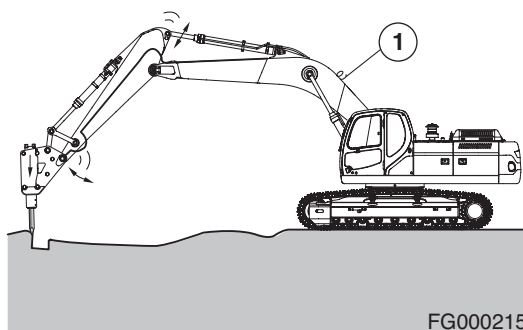

FG000215

Figure 73

Operation in Extreme Heat

Continuous operation of the machine in high temperatures may cause the machine to overheat. Monitor engine and transmission temperatures and stop machine for a cooling-off period whenever necessary.

1. Make frequent inspections and services of the fan and radiator. Check coolant level in radiator. Check grills and radiator fins for accumulation of dust, sand and insects which could block the cooling passages.
 - A. Formation of scale and rust in cooling system occurs more rapidly in extremely high temperatures. Change antifreeze each year to keep corrosion inhibitor at full strength.
 - B. If necessary, flush cooling system periodically to keep passage clear. Avoid use of water with a high alkali content which increases scale and rust formation.
2. Check level of battery electrolyte daily. Keep electrolyte above plates preventing damage to batteries. Use a slightly weaker electrolyte solution in hot climates. Dilute 1.28 specific gravity electrolyte as issued to 1.20 - 1.24 specific gravity readings at full charge. Recharge batteries whenever they reach a 1.16 specific gravity reading. Batteries self-discharge at a higher rate if left standing for long periods at high temperatures. If machine is to stand for several days, remove batteries and store in a cool place.



WARNING

Do not store acid type storage batteries near stacks of tires; the acid fumes have a harmful affect on rubber.

3. Service fuel system as directed in "Engine Fuel System" Section 5, of this manual. Check for water content before filling fuel tank. High temperatures and cooling off cause condensation in storage drums.
4. Lubricate as specified in "Periodic Service Chart and Table" Section 4, in this manual or Lubrication Decal on the machine.
5. Do not park machine in sun for long periods of time. When practical park machine under cover to protect it from sun, dirt and dust.
 - A. Cover inactive machine with tarpaulin if no suitable shelter is available. Protect engine compartment, transmission and hydraulics from entrance of dust.
 - B. In hot, damp, climates corrosive action will occur on all parts of the machine and will be accelerated during the rainy season. Rust and paint blisters will appear on metal surfaces and fungus growth on other surfaces.
 - C. Protect all unfinished, exposed surfaces with a film of preservative lubricating oil. Protect cables and terminals with ignition insulation compound. Apply paint or suitable rust preventive to damaged surfaces to protect them from rust and corrosion.

API: American Petroleum Institute.
ACEA: Association des Constructeurs Européens d'Automobiles.
ASTM: American Society of Testing and Material.
ISO: International Standardization Organization.
NLGI: National Lubricating Grease Institute.
SAE: Society of Automotive Engineers.

IMPORTANT

Do not mix oils from different manufacturers. *DOOSAN* does not endorse specific brands but does suggest that owners select quality oils whose suppliers provide assurance that required standards will always be met or exceeded.

Fluctuating daily or weekly extremes of temperature, or operation in subzero freezing weather may make it impractical to use straight weight lubricants. Use good judgement in selecting lubricant types that are appropriate for climate conditions.

Check Fuel Level



Use extreme safety precautions while refueling to prevent explosions or fire.

Immediately clean up any spill fuel.

1. At end of each work day, fill fuel tank. Add fuel through fuel fill tube (1, Figure 20). When working at a temperature of 0°C (32°F) or higher, use ASTM No. 2-D or its equivalent. At temperatures below 0°C (32°F) use ASTM No. 1-D or its equivalent.
2. Make sure that the fuel fill hose is grounded to the excavator before fueling begins.
3. Check the amount of fuel in the tank by observing the fuel tank sight gauge (2, Figure 20).

NOTE: See "Fluid Capacities" on page 4-8. for capacity.

4. The excavator may be equipped with the optional battery operated fuel fill pump. The pump assembly is in the hydraulic pump compartment. Put the suction hose of the pump into the fuel resupply tank. Turn the switch in the pump compartment "ON," and the fuel will be pumped into the excavator fuel tank.

NOTE: See "Fuel Transfer Pump (OptionAL)" on page 4-76, for further information.

5. Do not overfill the tank.
6. Securely tighten cap after fueling.

NOTE: If breather holes (3, Figure 21) in cap are clogged, a vacuum may form in the tank preventing proper fuel flow to engine. Keep holes in fuel cap clean.

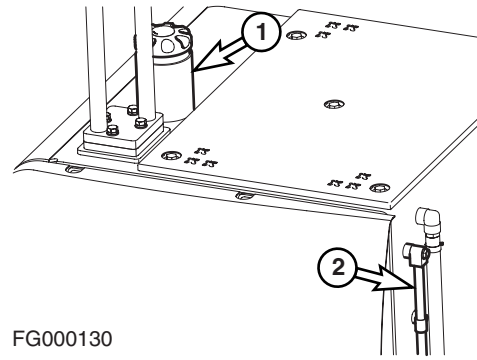

FG000130

Figure 20

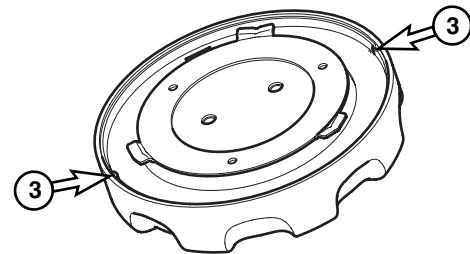

FG000317

Figure 21

Check for Leaks in Fuel System

1. Perform an inspection of the engine compartment to verify that the fuel system is not leaking. If any is noted, determine the source of the leak and repair.

250 HOUR / MONTHLY SERVICE

Perform All Daily and 50 Hour Service Checks

Grease Boom and Arm Joint Pins

Grease every 10 hours for first 100 hours and every 250 hours thereafter.

NOTE: *If the unit has been running or working in water the front attachment should be greased on a 10 hour / daily basis.*

- Position machine as shown below and lower the front attachment to the ground and shut down engine
- Press the grease fitting and inject grease with the grease gun on the marked point
- After injection, clean off the old grease that has been purged.

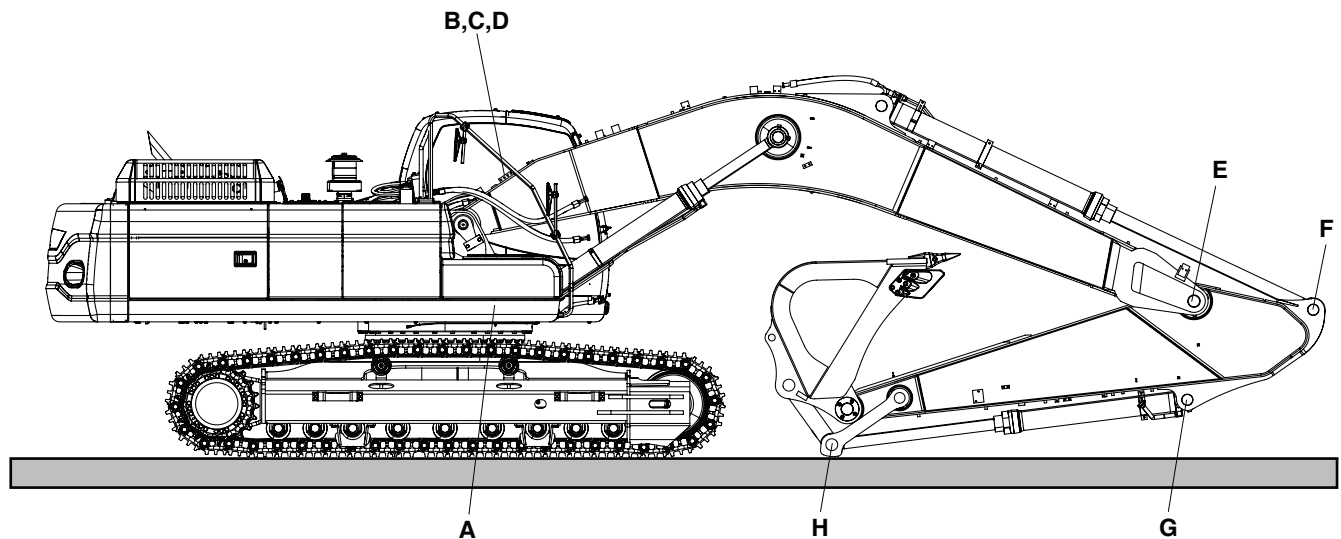

FG014613

Figure 39

Reference Number	Description
A	Boom Cylinder Head Pin (2 Points)
B	Boom Foot Pin (2 Points)
C	Boom Cylinder Rod Pin (2 Points)
D	Arm Cylinder Head Pin (1 Point)

Reference Number	Description
E	Boom Arm Joint Pin (2 Points)
F	Arm Cylinder Rod Pin (1 Point)
G	Bucket Cylinder Head Pin (1 Point)
H	Bucket Cylinder Rod Pin (1 Point)

Check and Clean Air-Conditioning Inner Filter

WARNING

All service and inspection of air-conditioning system should be performed with the starter switch in the "O" (OFF) position.

WARNING

If using compressed air to clean the element, make sure that proper eye protection is worn.

1. Remove the filter by pulling out ward the knob while pressing the upper part and lower part of the filter handle which is inside of the left rear part of the cabin.
 2. Use compressed air in the clean filter. If the filter is damaged replaced by a new one.
If the filter is very dirty use a mild soap or detergent and water to clean it.
-

IMPORTANT

If water was used to clean filter, be certain it is completely dry before installing.

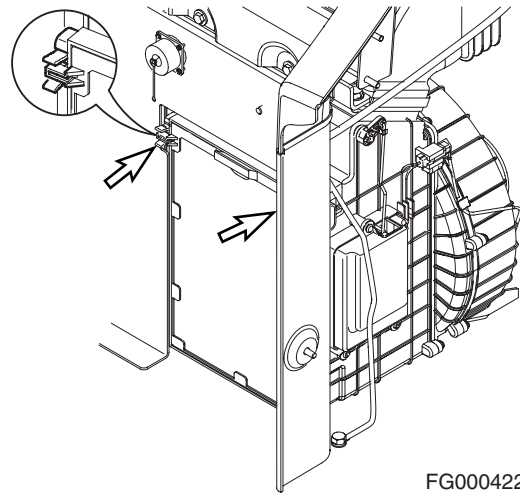

FG000422

Figure 57

Change Air-Conditioning Outer Filter

The unit is equipped with an air filtration system which filters out dirt and dust particles from air being circulated into operator's cabin. This filter should be cleaned out.

NOTE: *In the event that the unit is being operated in a dusty environment, the cleaning and replacement should be performed more frequently. If filter is damaged, replace damaged filter with a new one.*

WARNING

All service and inspection of air-conditioning system should be performed with the starter switch in the "O" (OFF) position.

NOTE: *All right and left call outs are based on the operator being seated in the operator's seat facing the front.*

1. Open the door in the left front of the machine, then remove four wing bolts and washers, and access cover (1, Figure 82).
2. Open the cover by unscrewing the knob (1, Figure 83) in the rear of the cabin.

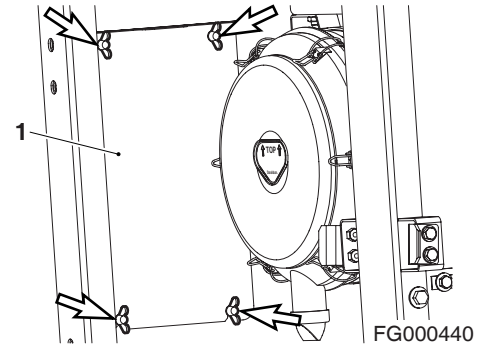

Figure 82

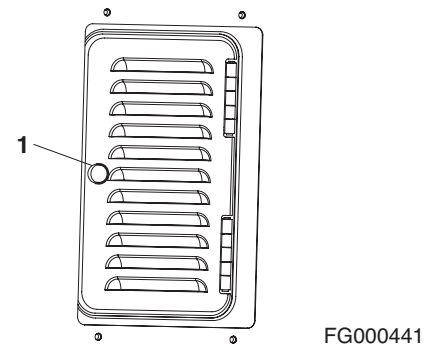

Figure 83

3. Remove filter (Figure 84) and replace with new one.
4. Reassemble in reverse order.

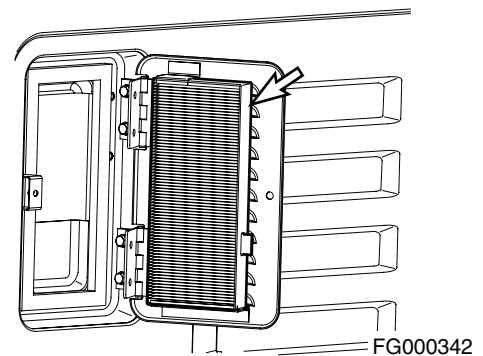

Figure 84

AIR-CONDITIONING SYSTEM

NOTE: See "Clean Air-Conditioning Outer Filter" on page 4-36.

Check Control Panel

When a function switch is pushed, the last setting has to be displayed on the LCD display.

When the light switch is turned to "I" position, the LED for illumination in the control panel has to turn "ON."

Check Air Conditioner Hoses

Check the hose for cracking and damage.



CAUTION

When a leak occurs, dirt will accumulate in the area where the leak is. Consult a *DOOSAN* distributor or sales agency.

Check Condenser

Inspect the condenser for dust and debris. Clean if necessary.

NOTE: See "Clean Radiator, Oil Cooler, Intercooler, Fuel Cooler and Air Conditioner Condenser Core" on page 4-38.

Check Magnetic Clutch

Check the magnetic clutch for dirt and interference.

Push the "A/C" switch in order to energize magnetic clutch and check the magnetic clutch.

Check Belt Tension

NOTE: See "Check Engine Fan Belt Tension" on page 4-29.

Bucket O-ring Replacement

WARNING

Due to possibility of flying metal objects, always wear safety helmet, protective gloves and eye protection when changing pins.

1. Inspect bucket O-rings on a routine basis. If worn or damaged, replacement is necessary.

2. Roll old O-ring (1, Figure 129) onto boss (2) around bucket pin (3). Remove bucket pin and move arm or bucket link (4) out of way.

3. Remove old O-ring and temporarily install new O-ring (1, Figure 130) onto bucket boss (2). Make sure that O-ring groove on both bucket link (4) and boss have been cleaned.

4. Realign arm or link with bucket pin hole and insert bucket pin (3, Figure 129).

5. Roll new O-ring (1, Figure 131) into O-ring groove.

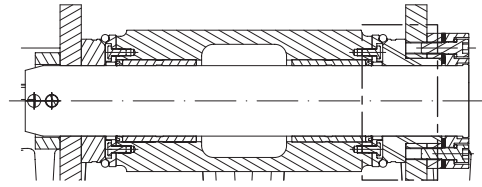

FG000502

Figure 128

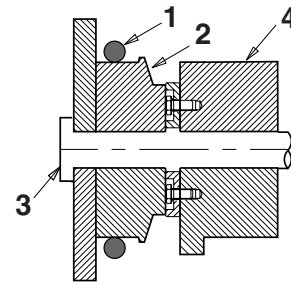

ARO1390L

Figure 129

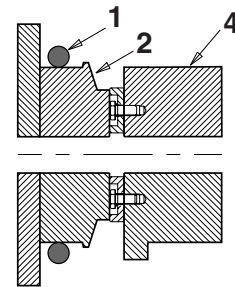

ARO1391L

Figure 130

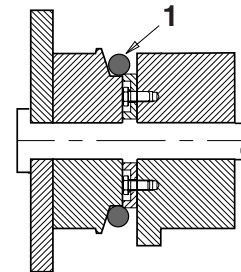

ARO1392L

Figure 131

The transfer pump is used to transfer fuel from a refueling source to the fuel tank. A check valve is installed in the inlet hose to prevent fuel from flowing back from fuel tank to source. A strainer is installed in inlet hose to prevent any foreign material from being introduced into transfer pump or fuel tank.

A thermal limiter, built into the motor, will automatically shut off power if motor is overheating to protect it from being damaged.

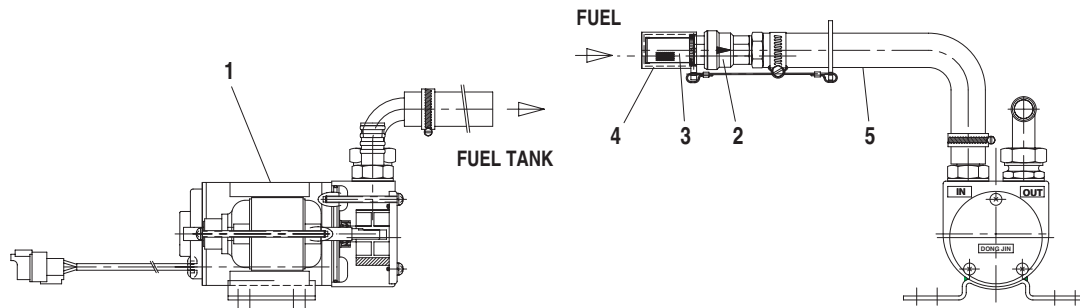

FG000161

Figure 138

Reference Number	Description
1	Body
2	Check Valve
3	Strainer

Reference Number	Description
4	Strainer Cap
5	Inlet Hose

1. Remove strainer cap (4, Figure 138) from strainer (3) on end of inlet hose (5).

NOTE: *Keep strainer cap (4, Figure 138) in a safe location to reseal strainer (3) after refueling is complete.*

2. Insert inlet hose (5, Figure 138) into refueling tank.
3. Turn fuel pump switch (Figure 139) inside of battery box on front side to "I" (ON) position.

NOTE: *Transfer pump rate of flow is approximately 35 liters/minute (9.24 U.S. gpm). Use extra care not to overfill fuel tank so that fuel does not overflow.*

4. Once fuel transfer is completed, immediately turn switch to "O" (OFF) position to stop pump.
5. Lift inlet hose (5, Figure 138) from fueling source and turn switch to "I" (ON) position for two - three seconds to drain remaining fuel from hose to fuel tank.
6. Install strainer cap (4, Figure 138) on inlet strainer (3) and return hose (5) to storage position.

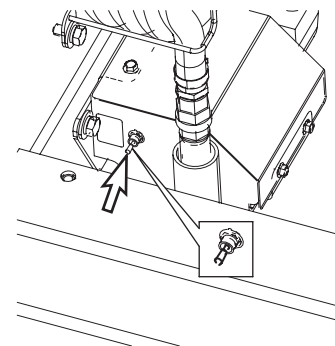

FG002166

Figure 139

Transportation

Obey all local, state or federal regulations for the transportation of the excavator. If unsure of regulations check with local authorities.

Check the intended route for road width, overhead clearances, weight restrictions, and traffic control regulations. Special approval or permits may be required.

LOADING AND UNLOADING

Warning for Counterweight and Front Attachment Removal



DANGER

DOOSAN warns any user, that the removal of the counterweight from the machine, front attachment or any other part, may affect the stability of the machine. This could cause unexpected movement, resulting in death or serious injuries. *DOOSAN* is not liable for any misuse.

Never remove the counterweight or front attachment unless the upper structure is in-line with the lower structure.

Never rotate the upper structure once the counterweight or front attachment has been removed.

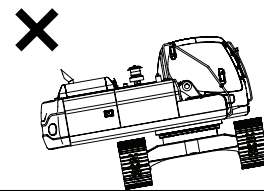
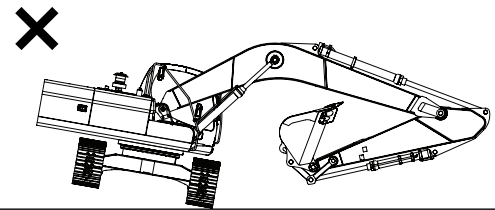

FG000371

Figure 1

TRAVEL SYSTEM

Problem	Cause	Remedy
Travel motion does not function.	Center joint leaking.	Repair or replace as required.
	Parking brake will not release.	Repair parking brake.
	Travel motor failed.	Repair or replace as required.
	Remote control valve failed.	Repair or replace as required.
	Wrong pilot line connection.	Reconnect pilot lines.
Travel speed is too low.	Track tension too high or too low.	Adjust tension.
	Damaged rollers or idlers.	Repair or replace as required.
	Track frame damaged.	Repair as required.
	Parking brake will not release.	Repair parking brake.

CLICK HERE TO **DOWNLOAD** THE COMPLETE MANUAL

- Thank you very much for reading the preview of the manual.
- You can download the complete manual from: www.heydownloads.com by clicking the link below



- Please note: If there is no response to CLICKING the link, please download this PDF first and then click on it.

CLICK HERE TO **DOWNLOAD** THE COMPLETE MANUAL