

***DOOSAN***

K1045080CE  
July 2014

FORESTRY MACHINE  
**Operation &  
Maintenance  
Manual**

**DX225LL**

**Serial Number 5017 and Up**

CLICK HERE TO **DOWNLOAD** THE COMPLETE MANUAL

- Thank you very much for reading the preview of the manual.
- You can download the complete manual from: [www.heydownloads.com](http://www.heydownloads.com) by clicking the link below



- Please note: If there is no response to CLICKING the link, please download this PDF first and then click on it.

CLICK HERE TO **DOWNLOAD** THE COMPLETE MANUAL

indicated whenever you see the Safety Alert "Triangle", no matter which signal word appears next to "Exclamation Point" symbol.

---

## CAUTION

This word is used on safety messages and safety labels and indicates potential of a hazardous situation that, if not avoided, could result in minor or moderate injury. It may also be used to alert against a generally unsafe practice.

---

---

## WARNING

This word is used on safety messages and safety labels and indicates potential of a hazardous situation that, if not avoided, could result in serious injury or death. It may also be used to alert against a highly unsafe practice.

---

---

## DANGER

This word is used on safety messages and safety labels and indicates an imminent hazard of a situation that, if not avoided, is very likely to cause death or extremely serious injury. It may also be used to alert against equipment that may explode or detonate if handled or treated carelessly.

---

---

### Other Signal Words

In addition to safety signal words, the following signal words are used to indicate proper and effective use of machine.

---

## IMPORTANT

This signal word identifies procedures which must be followed to avoid damage to machine.

---

**NOTE:** *The word "NOTE" identifies information for effective use.*

15. ISO Control Pattern (950205-03860)



**AVOID INJURY OR DEATH**

Read and understand the Operation & Maintenance Manual for more information.

Refer to "Operating Instructions" section of this manual for details regarding the work levers (joysticks) control functions.

---

BHL Control Pattern (US Only) (950205-03868)



**AVOID INJURY OR DEATH**

Read and understand the Operation & Maintenance Manual for more information.

Refer to "Operating Instructions" section of this manual for details regarding the work levers (joysticks) control functions.

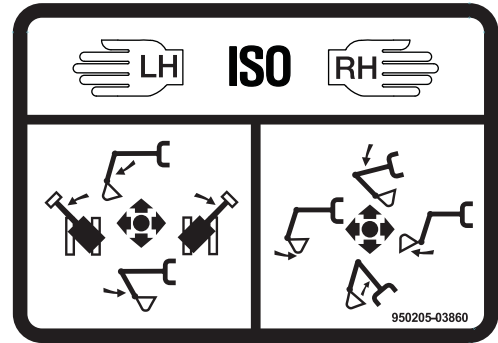

EX1301191

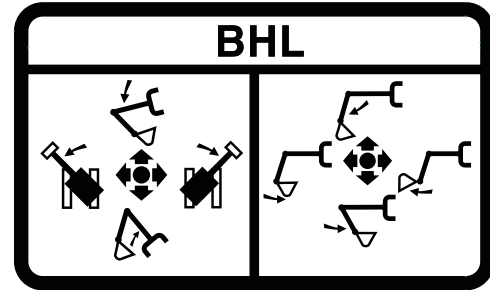

EX1301192

16. Impact Hazard (Optional) (950205-03963)



**AVOID DEATH OR SERIOUS INJURY**

- Activating the Intelligent Floating Boom Control with the tracks raised up can cause the machine to drop suddenly.
- Do not activate Intelligent Floating Boom Control when tracks are raised.
- Do not raise tracks when control is activated.

Refer to "Intelligent Floating Boom Control (Optional)" section of this manual for more information.

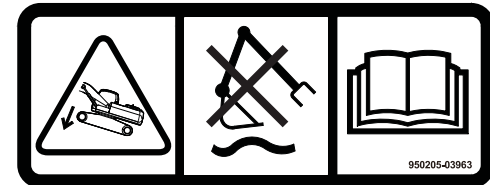

EX1301193

## Precautions When Handling Fluids at High Temperature

Immediately after operations are stopped, the coolant, engine oil, and hydraulic oil are at highest temperature and the radiator and hydraulic tank are still under pressure. Attempting to remove cap, drain the oil or coolant, or replacing the filters may lead to serious burns. Always wait for the temperature to go down, and follow the specified procedures when carrying out these operations.

To prevent hot coolant from spurting out, stop engine, wait for the coolant to cool, then loosen the cap slowly to relieve the pressure.

To prevent hot oil from spurting out, stop engine, wait for the oil to cool, then loosen the cap slowly to relieve the pressure.



Figure 7

HAOA050L



Figure 8

HAOA060L

## Asbestos Dust Hazard Prevention

Asbestos dust can be HAZARDOUS to your health if it is inhaled. Materials containing asbestos fiber can be present on work site. Breathing air that contains asbestos fiber can ultimately cause serious or fatal lung damage. To prevent lung damage from asbestos fiber, observe following precautions;

- Use a respirator that is approved for use in an asbestos-laden atmosphere.
- Never use compressed air for cleaning.
- Use water for cleaning to keep down the dust.
- Work on the machine or component with the wind at your back whenever possible.
- Always observe any regulations related to the work site and working environment.



Figure 9

ARO1770L

When traveling over bridges or structures on private land, check first that the bridge or structure can withstand the weight of the machine. When traveling on public roads, check with the local authorities and follow their instructions.

## Traveling on Slopes

Never jump onto a machine that is running away to stop it. There is danger of serious injury.

Traveling on slopes could result in the machine tipping over or slipping.

On hills, banks or slopes, carry the bucket approximately 20 - 30 cm (8 - 12 in) above the ground. In case of an emergency, quickly lower the bucket to the ground to help stop the machine.

Do not travel on grass, fallen leaves, or wet steel plates. Even slight slopes can cause the machine to slip to the side, so travel at low speed and make sure that the machine is always traveling directly up or down the slope.

Avoid changing the direction of travel on a slope. This could result in tipping or side slipping of the machine.

When possible, operate the machine up slopes and down slopes. Avoid operating the machine across the slope, when possible.

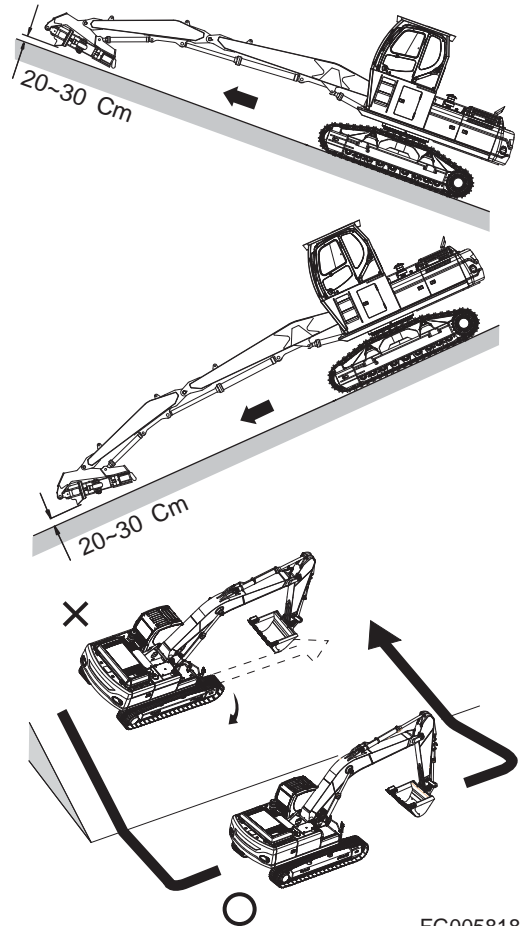

FG005818

Figure 21

## Precautions for Removal, Installation, and Storage of Attachments

Before starting removal and installation of attachments, decide on the team leader.

Do not allow anyone except the authorized workers close to the machine or attachment.

Place attachments that have been removed from the machine in a safe place so they do not fall. Put up a fence around the attachments and take other measures to prevent unauthorized persons from entering.



HDO1041L

Figure 39

## Precautions When Working on Machine

When carrying out maintenance operations on the machine, keep area around your feet clean and tidy to prevent falls. Always do the following;

- Do not spill oil or grease.
- Do not leave tools laying about.
- Watch your step when walking.

Never jump down from the machine. When getting on or off the machine, use the steps and handrails, and maintain a three-point contact (both feet and one hand or both hands and one foot) to support yourself securely.

If the job requires it, wear protective clothing.

To prevent injury from slipping or falling, when working on the hood or covers, never use any area except the area equipped with nonslip pads.



ARO1380L

Figure 40

## Lock Inspection Covers

When carrying out maintenance with the inspection cover open, lock the cover securely in position with the lock bar.

If maintenance work is carried out with the inspection cover open but not locked, there is a danger that it may suddenly close and cause injury if there is a gust of wind.

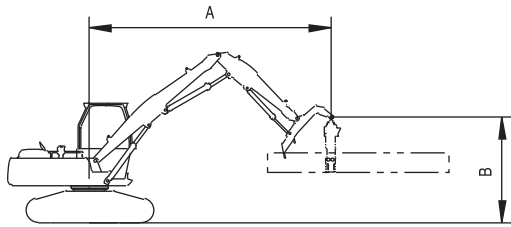

TRACK WIDTH : 3.6 m (11' 10")

Boom : 6.15 m (20' 2")

Arm : 3.66 m (12' 0")

HEEL : 0.81 m (2' 8")















GRAPPLE : NONE

SHOE : 700 mm

 : RATING OVER FRONT

 : RATING OVER SIDE

UNIT : 1,000 lb (1,000 kg)

A \ B	5 ft (1.52 m)		10 ft (3.05 m)		15 ft (4.57 m)		20 ft (6.10 m)		25 ft (7.62 m)		30 ft (9.14 m)		35 ft (10.67 m)	
														
40 ft (12.19 m)			* 30.31 (13.75)	* 30.31 (13.75)										
35 ft (10.67 m)					* 19.30 (8.75)	* 19.30 (8.75)	* 18.05 (8.19)	* 18.05 (8.19)						
30 ft (9.14 m)							* 16.23 (7.36)	* 16.23 (7.36)	* 15.52 (7.04)	13.06 (5.92)				
25 ft (7.62 m)							* 16.08 (7.29)	* 16.08 (7.29)	* 15.01 (6.81)	13.28 (6.02)	13.05 (5.92)	9.78 (4.48)		
20 ft (6.10 m)					* 19.05 (8.64)	* 19.05 (8.64)	* 17.00 (7.71)	* 17.00 (7.71)	* 15.38 (6.98)	13.24 (6.01)	13.18 (5.98)	9.91 (4.50)		
15 ft (4.57 m)					* 19.96 (9.05)	* 19.96 (9.05)	* 18.77 (8.51)	18.32 (8.31)	* 16.25 (7.37)	13.05 (5.92)	13.12 (5.95)	9.85 (4.47)		
10 ft (3.05 m)	* 10.48 (4.74)	* 10.48 (4.74)					* 20.95 (9.50)	17.75 (8.05)	17.09 (7.75)	12.76 (5.79)	12.99 (5.89)	9.72 (4.41)	10.25 (4.65)	7.64 (3.47)
5 ft (1.52 m)							* 22.78 (10.33)	17.14 (7.77)	16.76 (7.60)	12.45 (5.65)	12.83 (5.82)	9.57 (4.34)	10.22 (4.64)	7.61 (3.45)
0 (GROUND)							22.91 (10.39)	16.66 (7.56)	16.49 (7.48)	12.2 (5.53)	12.7 (5.76)	9.45 (4.29)		
-5 ft (-1.52 m)					* 18.94 (8.59)	* 18.94 (8.59)	* 22.52 (10.21)	16.41 (7.44)	16.33 (7.41)	12.05 (5.47)	12.64 (5.73)	9.39 (4.26)		
-10 ft (-3.05 m)							* 19.59 (8.89)	16.37 (7.43)						

1. LOAD POINT IS THE HOOK ON THE BACK OF THE BUCKET.
2. \* RATED LOADS ARE BASED ON HYDRAULIC CAPACITY.
3. RATED LOADS DO NOT EXCEED 87 % OF HYD. CAPACITY OR 75 % OF TIPPING CAPACITY.

FG012999

### 3. Auxiliary Mode Switch

When the control system is out of order, the pump system can be controlled manually.

- O. In this position, the manual pump control is "OFF".
- I. In this position, the manual pump control is "ON".



## CAUTION

### AVOID INJURY

**Be sure to turn pump control to "O" (OFF) position, after the control system is operating properly.**

---

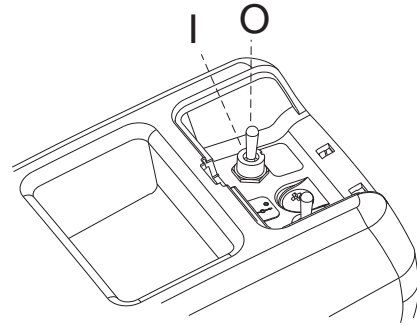

Figure 6

### 4. Engine Emergency Stop Switch

If the engine does not stop when using the starter switch, it can be stopped by moving the engine emergency stop switch to "I" (EMERGENCY STOP) position.

- O. In this position, the engine emergency stop system is "OFF".
- I. In this position, "EMERGENCY STOP" is selected. The engine will stop.

**NOTE:** *When released, the switch will return to its original position "O" (OFF) position.*

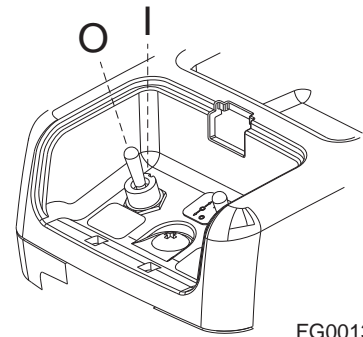

Figure 7

### 5. Audio Control Panel

The audio system can be remotely controlled using this panel.

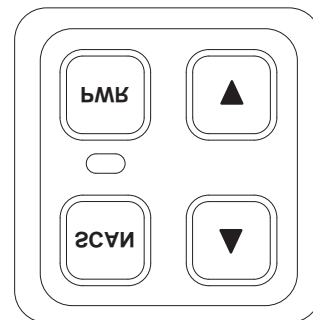

Figure 8

## Functional check

When the engine starter switch is turned to "I" (ON) position, all gauge bands, switch/button indicator lights and warning lights will turn "ON" and the alarm buzzer will sound about two seconds.

During this functional check, a LOGO will appear on the multi function gauge in the graphic information area (3 and 4, Figure 33).

## Password Activated

If a password has already been set and the system has been "LOCKED", the password display will appear on the screen once the functional check has been completed. Enter the password into the text area and then engage the starter.

**NOTE:** Refer to "Set Password (Lock and Unlock)" on page 2-38, for further details.



---

**AVOID INJURY**

**If the password does not match the stored password, the engine will not start.**

---

## 1. Fuel Gauge

Shows remaining fuel quantity in tank.

BLUE ZONE (■) - Indicates a normal fuel quantity.

RED ZONE (■) - Indicates that the fuel level is low.

If the gauge pointer moves into the red zone, the fuel level symbol will turn "ON", and be display in the screen. Stop operation and immediately and add fuel.

**NOTE:** See "Abnormal State Warning Symbols" on page 2-26, for location of this warning symbol and others.

Check the fuel level on firm and level ground.

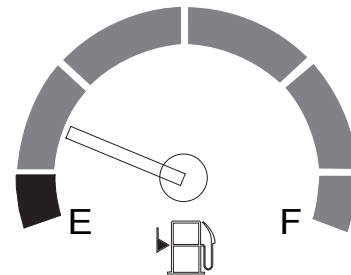

**Figure 34**

FG013666

# MODE SELECTOR BUTTONS

1. Power Mode Selector Button
2. Economy Mode Selector Button
3. Auto Idle Selector Button
4. Flow Control Button



FG013707

Figure 62

## 1. Power Mode Selector Button

This power mode is suitable for heavy-duty work that requires a high operating speed. Push this button to turn power mode "ON" or "OFF".

When the power mode button is pushed to "ON" position, an indicator light above it turns "ON".

When the power mode button is pushed again, it is turned "OFF" and the power mode is deactivated and returns to the standard operating mode.

When turning the engine starter switch to "I" (ON) position, the power mode is automatically defaulted to "Standard Mode".

**NOTE:** For further details, see "Mode Selection" on page 3-19.



FG013709

Figure 63

## 2. Economy Mode Selector Button

Economy mode is used for light loading work, when this mode selected it will reduce noise and fuel consumption with standard mode.

When the economy mode button is pushed to "ON" position, a symbol appears on the screen.

**NOTE:** When the economy mode button is pushed again, it is turned "OFF" and the economy mode is deactivated and returns to the standard operating mode.



FG013710

Figure 64

selected by using the "UP" (▲) or "DOWN" (▼) buttons, and then selected by pressing the "SELECT" (↵) button.

Press "ESC" (⏏) button (3, Figure 68) for 1 more second, it returns to main menu.

According to the selection of adoption (lock) or nonadoption (unlock), the password function will be in working or nonworking.

When you want to change a password, follow below procedure.

1. Move the cursor to "Change Password".
2. Input desired 4 digits password using selector buttons (at the first column). Input the same password one more time (at the second column)
3. Select adoption (lock) or nonadoption (unlock) at set password menu.

**NOTE:** *Keep in mind never to forget password.*

**NOTE:** *Please contact a DOOSAN distributor, if you forget your password.*

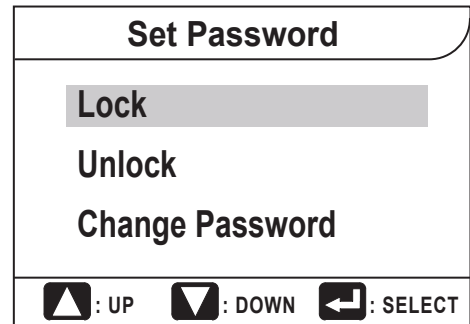

FG013718

**Figure 91**

# STEREO

Before operating the stereo or CD player, read operation manual enclosed with stereo.

## Stereo

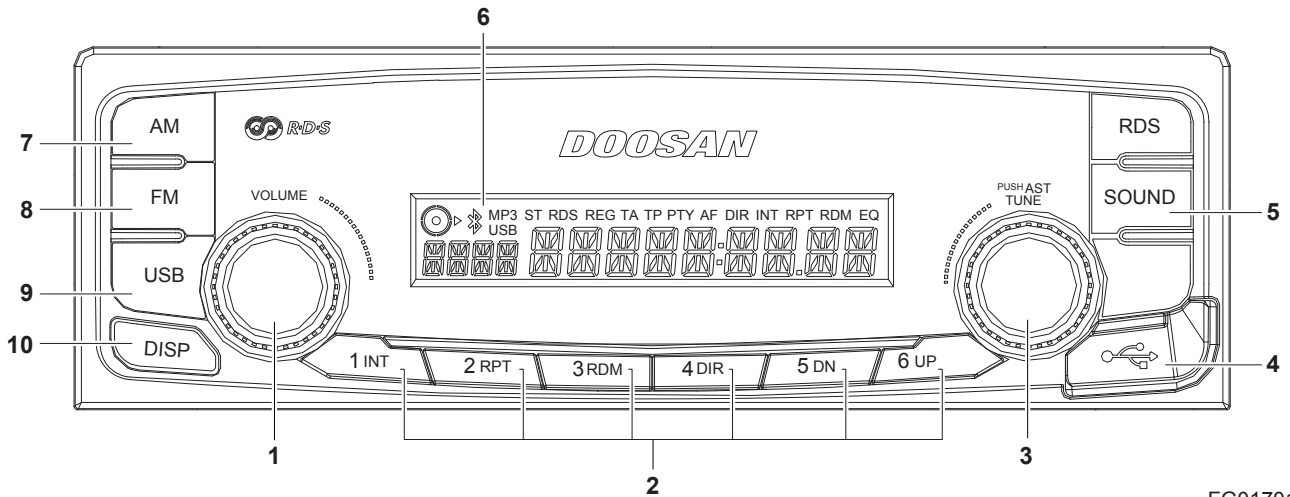

Figure 116

FG017016

Reference Number	Description
1	Power/Volume Control
2	Preset Station
3	Tuning Up/Down
4	USB Loading Port
5	Sound Mode Selector

Reference Number	Description
6	LCD
7	AM Selection
8	FM Selection
9	USB Selection
10	Display Mode Control

## CD Player (Optional)

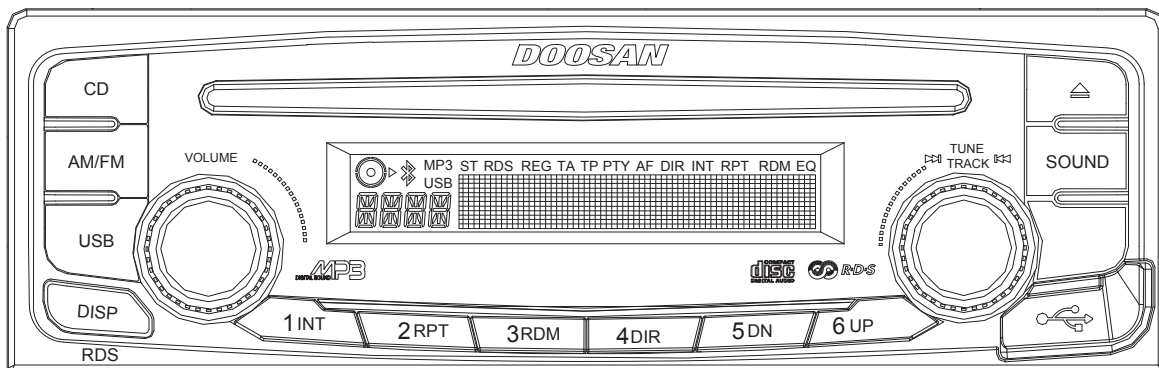

Figure 117

FG017017

# DOORS AND ACCESS COVERS

## Door Side Latch

1. The door side latch (1, Figure 137) is used to secured door to side of cabin when it is opened.

**NOTE:** *Keep door closed and locked when machine is not in use.*

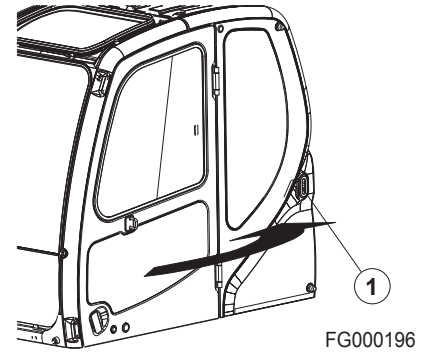

Figure 137

2. To release door from side of cabin, push latch lever (2, Figure 138) down. The latch lever is to the left of operator's seat.

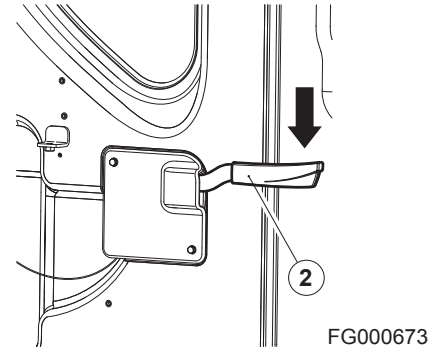

Figure 138

## Cabin Riser Access Door

This compartment allows access to tilt cab bolts and cylinder.

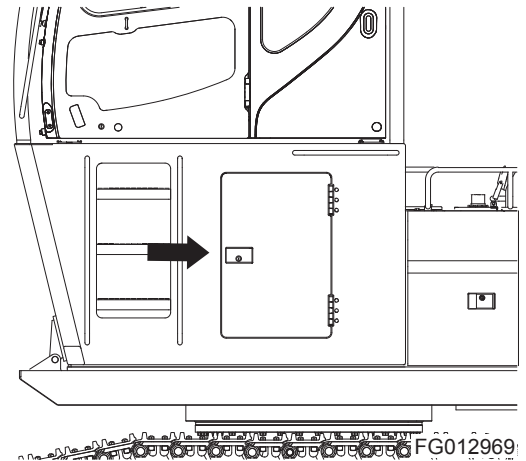

Figure 139

CLICK HERE TO **DOWNLOAD** THE COMPLETE MANUAL

- Thank you very much for reading the preview of the manual.
- You can download the complete manual from: [www.heydownloads.com](http://www.heydownloads.com) by clicking the link below



- Please note: If there is no response to CLICKING the link, please download this PDF first and then click on it.

CLICK HERE TO **DOWNLOAD** THE COMPLETE MANUAL

8. After warming unit, check all operating indicators to make sure that all engine systems (oil pressure, coolant, etc.) are in the normal operating range. If any problems are noticed, stop engine. Normal indicators are:

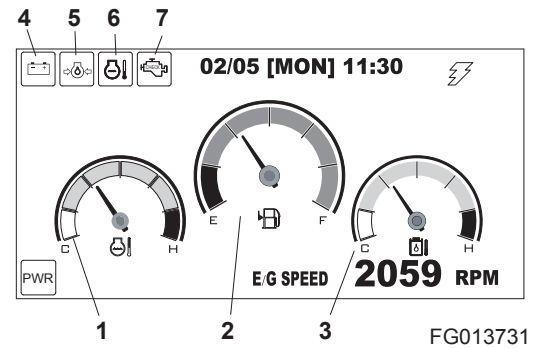

Figure 6

No.	Instrument Panel Light or Gauge	Indicator Reading
1	Engine Coolant Temperature Gauge	Blue Range
2	Fuel Gauge	Blue Range
3	Hydraulic Oil Temperature Gauge	Blue Range
4	Charging Warning	OFF
5	Engine Oil Pressure Warning	OFF
6	Engine Coolant Temperature Warning	OFF
7	Engine Check Warning	OFF

9. Check color of exhaust smoke.
- No color or light blue - Engine is running in good condition.
  - Black - Incomplete combustion. Check cause.
  - White or dark blue - Engine is burning engine oil. Check cause.
10. Check for usual engine vibration and noises. If any are heard or felt, investigate cause.

**NOTE:** *If engine coolant temperature gauge pointer moves into the red zone, the engine coolant temperature warning light will turn "ON", a warning buzzer will sound, and the engine speed will be automatically reduced. Allow the engine to run at low idle speed until the temperature gauge registers in the blue zone again. When the blue zone is reached, allow the engine to idle for an additional three - five minutes before shutting down the engine. If not allowed to idle, heat surge may develop which will damage the engine. Allowing the engine to idle will dissipate heat. Check the coolant level, look for a loose fan belt, inspect for debris around radiator, and so on.*

## Travel Control Lever Operation

1. To travel straight (Figure 27), push both travel control levers/pedals fully forward or backwards. The farther the levers/pedals are pressed, the faster the travel speed.

**NOTE:** "X" is the sprocket end of the track.

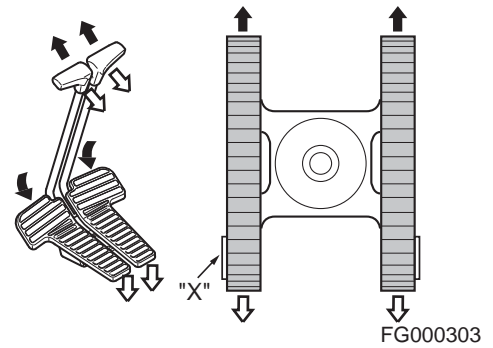

Figure 27

2. Pivot turns (Figure 28) are made by rotating only one track forward or backward. The machine will pivot on the nonmoving track.

**NOTE:** "X" is the sprocket end of the track.

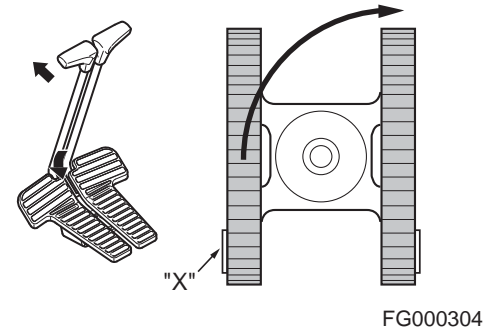

Figure 28

3. Spin turns (Figure 29) are made by rotating one track forward and one track backward. The machine will spin around its center point, thus counterrotating.

**NOTE:** "X" is the sprocket end of the track.

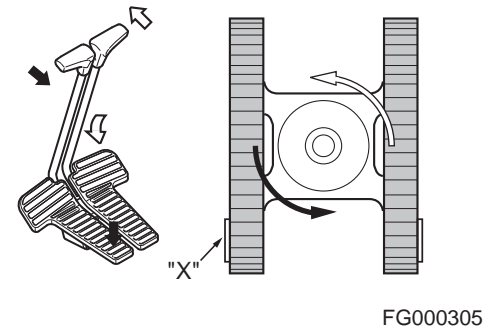

Figure 29

4. Stopping travel (Figure 30) - Returning travel levers to "NEUTRAL" position will automatically apply brakes and stop forest machine.

**NOTE:** "X" is the sprocket end of the track.

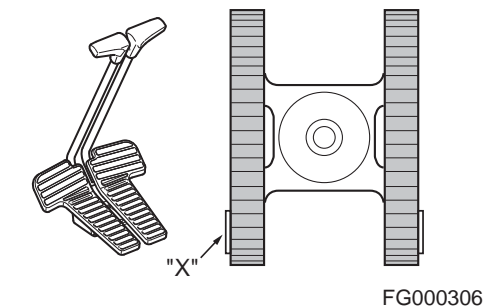

Figure 30

13. Do not use the grapple rotation control to stop the rotation of large logs or loads. This circuit is protected by crossover reliefs which do allow stopping the rotation of the empty grapple, but continuous use of this feature for large loads can cause rotation motor failures.
14. Do not swing Boom or brake unnecessarily fast. All can cause accidents.
15. ADDITIONAL PRECAUTIONS MAY BE NECESSARY, DEPENDING ON CONDITIONS AT THE WORK SITE. The manufacturer has no direct control over machine application, operation, inspection lubrication, or maintenance. Therefore conformance with GOOD SAFETY PRACTICE in these areas are the responsibility of the user.
16. Do not swing a log out of bind or swing-hammer a log into the saddle of a load. This can cause sever structural damage.
17. Do not allow anyone to ride the attachment or the load. This is an extremely dangerous practice.

## **Always Observe These Precautions**

If the hydraulic fluid escapes, the attachment can fall immediately, endangering anything below. Make sure the blocking or solid ground (not the hydraulic oil) is actually supporting the attachment (or loader).

Release system pressure before attempting to make adjustments or repairs. Consult the manufacturer's instructions for procedures. **PRESSURE MUST BE RELEASED CORRECTLY. REMEMBER,** Pressure can be maintained in the hydraulic and air circuits long after the engine has been stop.

## Operation in Salt Water Areas

The corrosive effect of salt water and salt water spray is very extensive. When operating in salt water areas, observe the following precautions.

1. When exposed to salt water, dry machine thoroughly and rinse with fresh water as soon as possible.
2. Keep all exposed surfaces coated with preservative lubricating oil. Pay particular attention to damaged paint surfaces.
3. Keep all painted surfaces in good repair.
4. Lubricate machine as prescribed on lubrication chart on machine or "Periodic Service Table and Chart" Section 4, in this manual. Shorten lubricating intervals for parts subject to exposure to salt water, if found necessary.

## Operation at High Altitudes

Normally, operation of machine at high altitudes will be as outlined in extreme cold. Before operating at high altitudes, engine fuel and air mixture may have to be adjusted according to appropriate engine manual.







1. Check engine operating temperature for evidence of overheating. The pressure cap on radiator must make a perfect seal to maintain coolant pressure in the system.







# FLUID CAPACITIES

Component		Capacity
Engine	Oil Pan with Filter	27 liters (7.1 U.S. gal.)
	Cooling System	30 liters (8 U.S. gal.)
Fuel Tank		1,000 liters (264 U.S. gal.)
Hydraulic Oil	Tank Level	141 liters (37.2 U.S. gal.)
	Full	195 liters (51.5 U.S. gal.)
	System	240 liters (63.4 U.S. gal.)
Travel Reduction Gear (Each)		6 liters (1.6 U.S. gal.)
Swing Reduction Gear		4 liters (1.05 U.S. gal.)

## LUBRICATION AND SERVICE CHART

Lubrication and service chart is on the inside of battery box cover. The symbols shown here are used in the lubrication and service chart on the next page.

Symbol	Description
	Lubrication
	Gear Oil (Swing Device, Travel Device)
	Engine Oil
	Engine Oil Filter
	Hydraulic Oil
	Hydraulic Oil Return Filter
	Hydraulic Oil Tank Breather

Symbol	Description
	Coolant
	Air Cleaner Element
	Fuel Filter
	Air Conditioner Filter
	Drain Water
	Fuel Cap Filter

# Check Oil Level of Swing Reduction Device



## AVOID DEATH OR SERIOUS INJURY

The gear oil is very hot after the machine has been operating. Shut all systems down and allow them to cool. Before fully removing any motor case inspection port plug, etc., loosen the plug slightly to allow pressurized air to escape.

**NOTE:** When checking level using a dipstick always remove and wipe it clean before making final level check.

1. Remove dipstick (1, Figure 25) and wipe the oil from the dipstick with a cloth.
2. Insert dipstick (1, Figure 25) fully into dipstick tube.

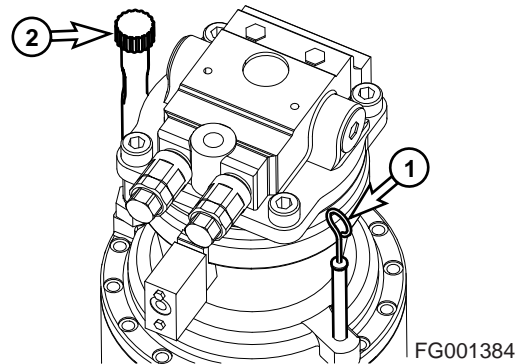

Figure 25

3. When dipstick is pulled out, oil level must be between "HIGH" and "LOW" marks on dipstick.

**NOTE:** If oil is above "HIGH" mark on dipstick, some must be drained to proper level.

4. If the oil does not reach the "L" mark on the dipstick, add oil through fill port (2, Figure 25).

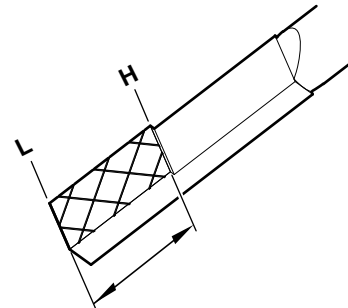

Figure 26

5. If the oil level exceeds the "H" mark on the dipstick, open cap (3, Figure 27) of drain valve and connect hose (4) to the valve. Drain the excessive oil into a suitable container.

**NOTE:** Dispose of drained fluids in compliance with all applicable environmental laws and regulations.

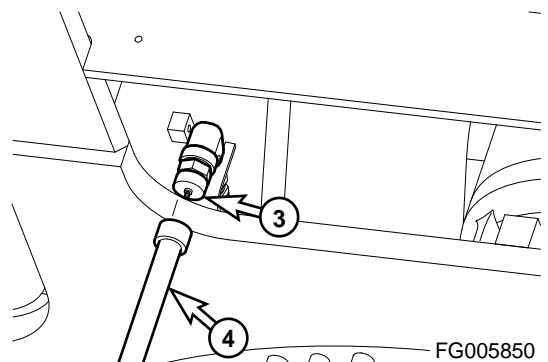

Figure 27

- Head (2 Points)

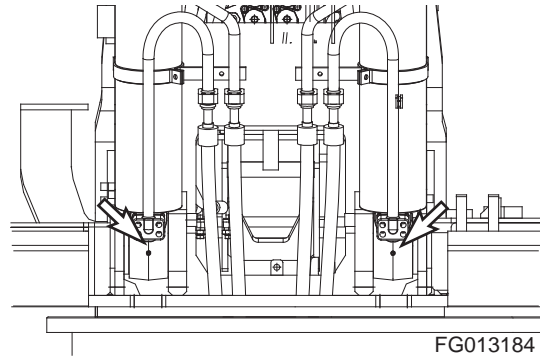

Figure 44

- F. Swivel Link Pins (2 Points)

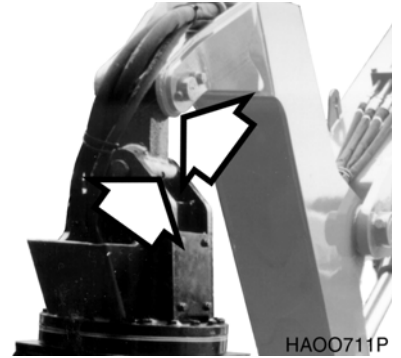

Figure 45

- G. Rotation Bearing (1 Point)

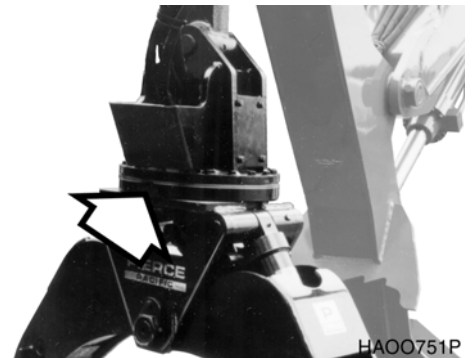

Figure 46

- H. Grapple Cylinder Pins (4 Points)

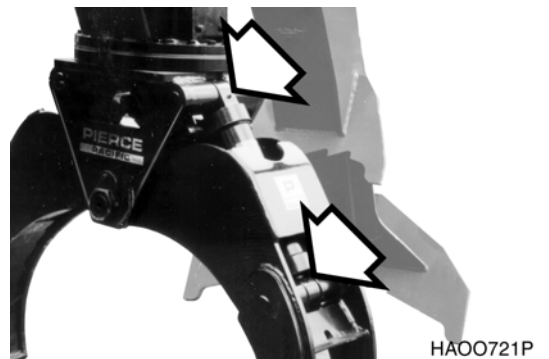

Figure 47

# Clean Radiator, Oil Cooler, Intercooler, Fuel Cooler and Air Conditioner Condenser Core



## WARNING

### AVOID DEATH OR SERIOUS INJURY

If compressed air, steam or water hit your body directly, there is danger of injury. Always wear protective glasses, mask and safety shoes during the cleaning process. Make sure that all extra personnel are clear of the work area.

1. Open the rear left door and engine cover.
2. Loosen the wing bolt(s) and remove dust net from in front of radiator, oil cooler and intercooler.
3. Clean the outside of the radiator and oil cooler, intercooler and fuel cooler with compressed air, steam or water. Wash from the outside of the engine compartment inwards. Repeat the cleaning process from the inside of the engine compartment outwards to remove all dirt and debris.

**NOTE:** Clean dust net and install it after cleaning radiator, oil cooler, intercooler and fuel cooler.

4. Clean air conditioner condenser core with compressed air, steam or water.

## IMPORTANT

To prevent damage to the cores, apply compressed air from an appropriated distance. Damaged core can cause water leakage or overheating. In a dusty site, check the core daily, irrespective of the maintenance interval.

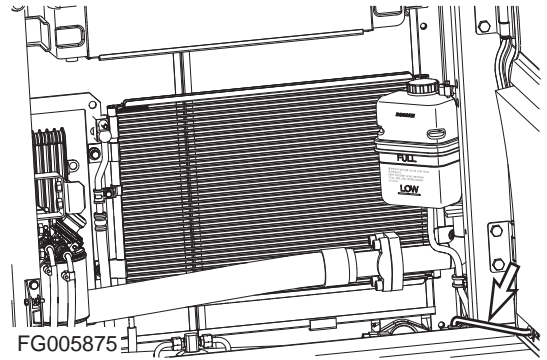

Figure 64

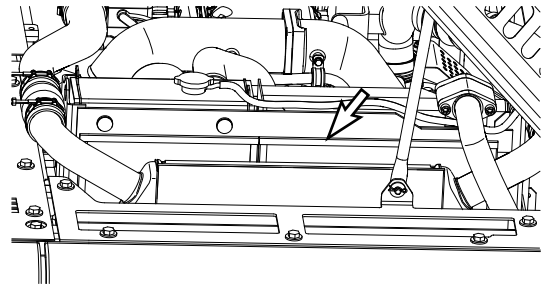

Figure 65

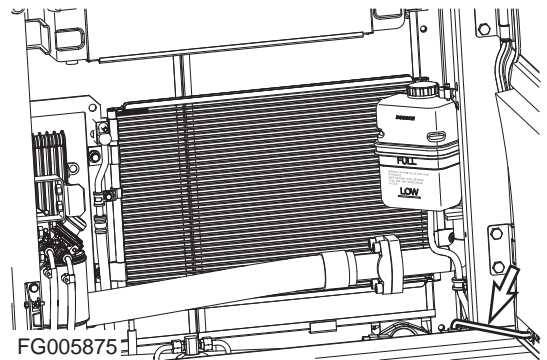

Figure 66

## Change Air-Conditioning Outer Filter

The unit is equipped with an air filtration system which filters out dirt and dust particles from air being circulated into operator's cabin. This filter must be cleaned out.

**NOTE:** *In the unit is being operated in a dusty environment, the cleaning and replacement must be performed more frequently. If filter is damaged, replace damaged filter with a new one.*



### WARNING

#### AVOID DEATH OR SERIOUS INJURY

**All service and inspection of air-conditioning system must be performed with the starter switch in the "O" (OFF) position.**

**NOTE:** *All right and left call outs are based on the operator being seated in the operator's seat facing the front.*

1. Open the door in the left front of the machine, then remove four wing bolts and washers, and access cover (1, Figure 91).
2. Open the cover by unscrewing the knob (1, Figure 92) in the rear of the cabin.

3. Remove filter (Figure 93) and replace with new one.
4. Reassemble in reverse order.

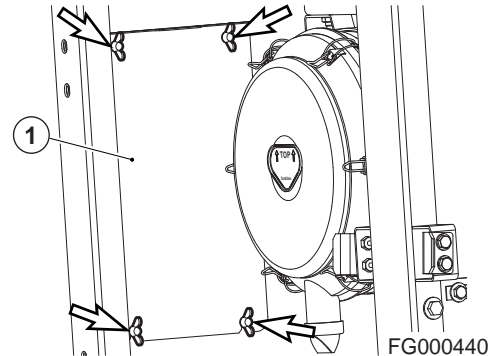

Figure 91

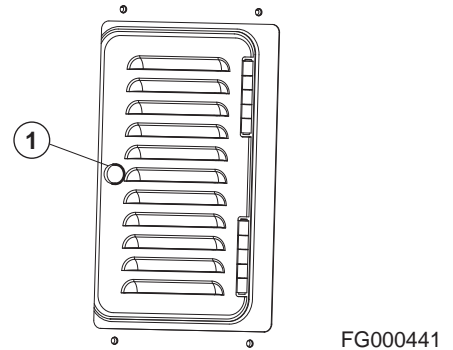

Figure 92

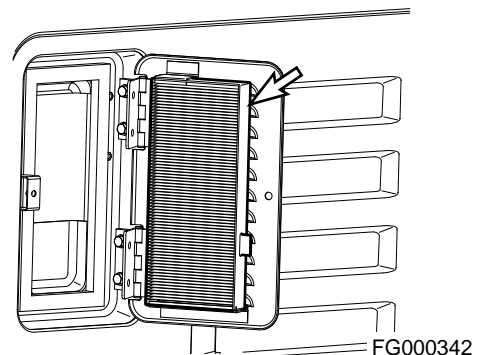

Figure 93

10. Fill the hydraulic oil tank. Check level using sight gauge on side of tank.
11. Place spring (3, Figure 113) on rod (4) and assemble cover (2).
12. After replacing and cleaning the hydraulic oil, filter and strainer, vent the system. See "Venting and Priming Hydraulic System on page 4-83".

---

## IMPORTANT

---

**When the hydraulic breaker is being used, because of the higher heat generated by this unit.**

---

13. Check level of hydraulic oil tank. See on page 4-15.

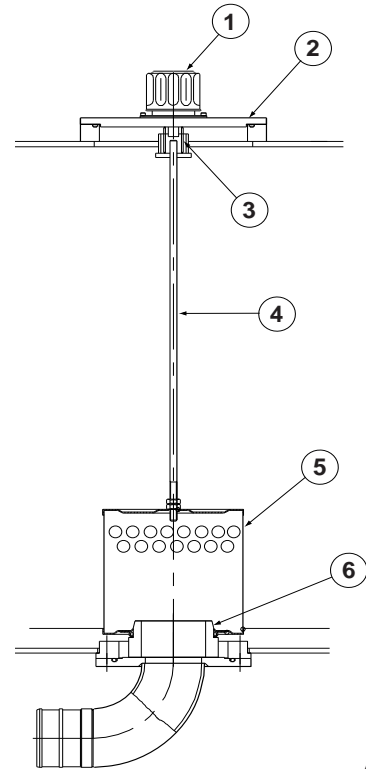

**Figure 113**

ARO1720L

### **Check Alternator and Starter\*\***

\*\*These checks need to be completed by an authorized DOOSAN dealer.

### **Check All Rubber Antivibration Shock Mounts**

### **Perform and Record the Results of Cycle Time Tests**

### **Inspect Machine to Check for Cracked or Broken Welds or other Structural Damage**

### **Check, Adjust Valve Clearance \*\***

### **Check Head Bolt Torques**

16. Tightening bolt for track guard

- Tool: 30 mm (🔧)
- Torque: 55 kg•m (539 Nm, 398 ft lb)

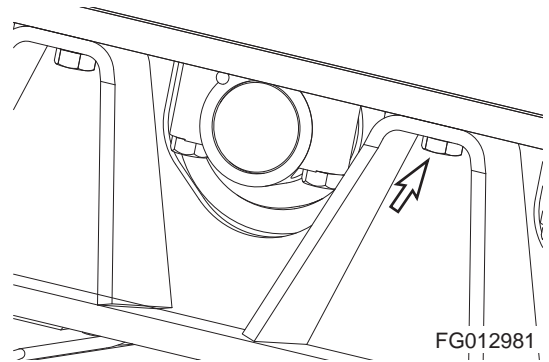

Figure 134

17. Bolt for track shoes

Tighten the bolts in the order as shown in the Figure 132 (1 → 4)

- Tool: 30 mm (🔧)
- Torque: 78 kg•m (765 Nm, 564 ft lb)

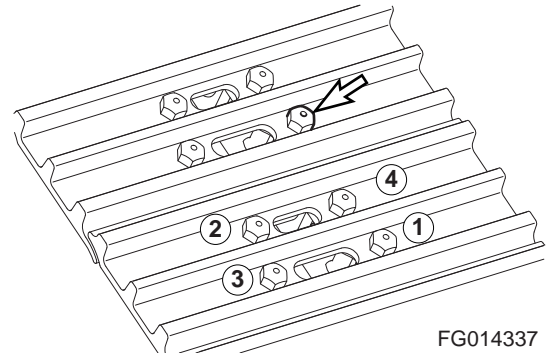

Figure 135

18. Fixing bolt for front pin

- Tool: 24 mm (🔧)
- Torque: 27 kg•m (265 Nm, 195 ft lb)

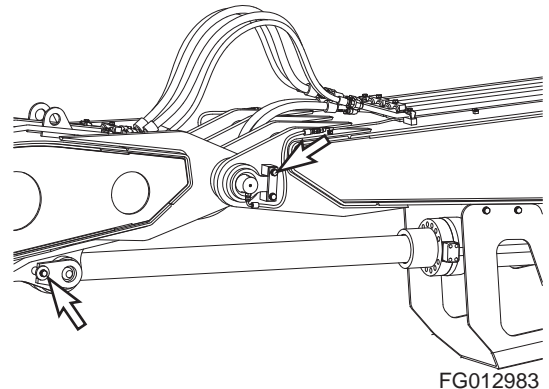

Figure 136

19. Grease valve for track adjuster

- Tool: 27 mm (🔧)
- Torque: 14 kg•m (137 Nm, 101 ft lb)

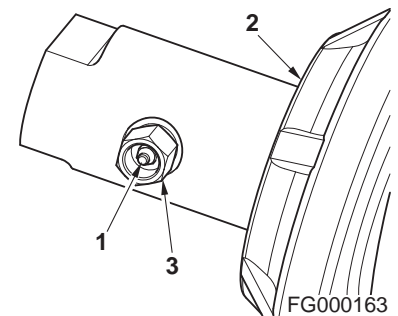

Figure 137

1. Remove strainer cap (4, Figure 143) from strainer (3) on end of inlet hose (5).

**NOTE:** *Keep strainer cap (4, Figure 143) in a safe location to reseal strainer (3) after refueling is complete.*

2. Insert inlet hose (5, Figure 143) into refueling tank.
3. Turn fuel pump switch (Figure 144) inside of battery box on front side to "I" (ON) position.

**NOTE:** *Transfer pump rate of flow is approximately 35 liters/minute (9.24 U.S. gpm). Use extra care not to overfill fuel tank so that fuel does not over flow.*

4. Once fuel transfer is completed, immediately turn switch to "O" (OFF) position to stop pump.
5. Lift inlet hose (5, Figure 143) from fueling source and turn switch to "I" (ON) position for two - three seconds to drain remaining fuel from hose to fuel tank.
6. Install strainer cap (4, Figure 143) on inlet strainer (3) and return hose (5) to storage position.

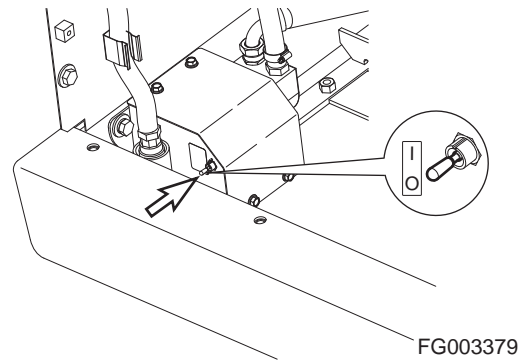

**Figure 144**

# Transportation

Obey all local, state or federal regulations for the transportation of the forest machine. If unsure of regulations check with local authorities.

Check the intended route for road width, overhead clearances, weight restrictions, and traffic control regulations. Special approval or permits may be required.

## LOADING AND UNLOADING

### Warning for Counterweight and Front Attachment Removal



**DANGER**

---

**AVOID DEATH**

DOOSAN warns any user, that removal of the counterweight from the machine, front attachment or any other part, may affect the stability of the machine. This could cause unexpected movement, resulting in death or serious injuries. DOOSAN is not liable for any misuse.

Never remove the counterweight or front attachment unless the upper structure is in-line with the lower structure.

Never rotate the upper structure once the counterweight or front attachment has been removed.

---

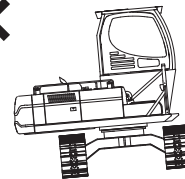
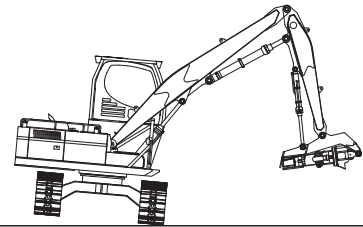

FG012966

Figure 1

# SWING SYSTEM

Problem	Cause	Remedy
No swinging motion.	Swing brake valve faulty.	Replace brake valve.
	Hydraulic timer faulty.	Replace timer.
	Low brake release pressure.	Adjust pressures.
	Swing motor failed.	Replace swing motor.
	Remote control valve failed.	Replace control valve.
	Wrong pilot line connection.	Reconnect pilot lines.
Swing motion jerky.	Swing gear worn.	Replace swing gear.
	Swing bearing damaged.	Replace bearing.
	Improper lubrication.	Add grease.

# TRAVEL SYSTEM

Problem	Cause	Remedy
Travel motion does not function.	Center joint leaking.	Repair or replace as required.
	Parking brake will not release.	Repair parking brake.
	Travel motor failed.	Repair or replace as required.
	Remote control valve failed.	Repair or replace as required.
	Wrong pilot line connection.	Reconnect pilot lines.
Travel speed is too low.	Track tension too high or too low.	Adjust tension.
	Damaged rollers or idlers.	Repair or replace as required.
	Track frame damaged.	Repair as required.
	Parking brake will not release.	Repair parking brake.

CLICK HERE TO **DOWNLOAD** THE COMPLETE MANUAL

- Thank you very much for reading the preview of the manual.
- You can download the complete manual from: [www.heydownloads.com](http://www.heydownloads.com) by clicking the link below



- Please note: If there is no response to CLICKING the link, please download this PDF first and then click on it.

CLICK HERE TO **DOWNLOAD** THE COMPLETE MANUAL