



Doosan Infracore

DX140LC

Serial Number 5001 thru 5456

Operation & Maintenance Manual

**K1030026E-1
(Equipped with NON-ROPS)
February 2011**

CLICK HERE TO **DOWNLOAD** THE COMPLETE MANUAL

- Thank you very much for reading the preview of the manual.
- You can download the complete manual from: www.heydownloads.com by clicking the link below



- Please note: If there is no response to CLICKING the link, please download this PDF first and then click on it.

CLICK HERE TO **DOWNLOAD** THE COMPLETE MANUAL



SAFETY ALERT SYMBOL



Be Prepared - Get to Know All Operating and Safety Instructions.

This is the Safety Alert Symbol. Wherever it appears in this manual or on safety signs on the machine you should be alert to the potential for personal injury or accidents. Always observe safety precautions and follow recommended procedures.

Learn the Signal Words Used with the Safety Alert Symbol

The words "CAUTION," "Warning," and "DANGER" used throughout this manual and on decals on the machine indicate degree of risk of hazards or unsafe practices. All three degrees of risk indicate that safety is involved. Observe precautions indicated whenever you see the Safety Alert "Triangle," no matter which signal word appears next to the "Exclamation Point" symbol.



CAUTION!

This word is used on safety messages and safety labels and indicates potential threat of a hazardous situation that, if not avoided, could result in minor or moderate injury. It may also be used to alert against a generally unsafe practice.



WARNING!

This word is used on safety messages and safety labels and indicates potential threat of a hazardous situation that, if not avoided, could result in serious injury or death. It may also be used to alert against highly unsafe practice.



DANGER!

This word is used on safety messages and safety labels and indicates an imminent hazard of a situation that, if not avoided, is very likely to cause death or extremely serious injury. It may also be used to alert against equipment that may detonate or explode if handled or treated carelessly.

Safety precautions are described in SAFETY from page 1-5 on.

**15. Keep Out of the Swing Area
(2190-3379A, K1008571)**

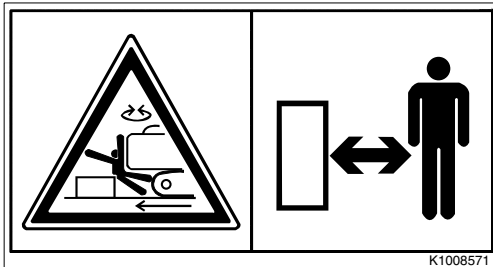

FG009521

**16. Warnings for Front Attachments
(190-00652)**

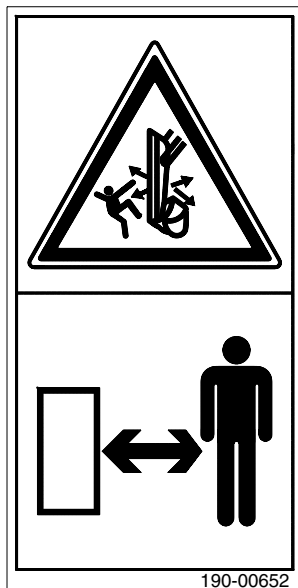

ARO1230L

Emergency Exit

This machine is equipped with a glass breaking tool. It is behind the operator seat in the upper right corner of the cabin. This tool can be used in case of an emergency that requires the breaking of glass to exit from the operator's cabin. Grip the handle firmly and use the sharp point to break the glass.



WARNING!

Protect your eyes when breaking the glass.

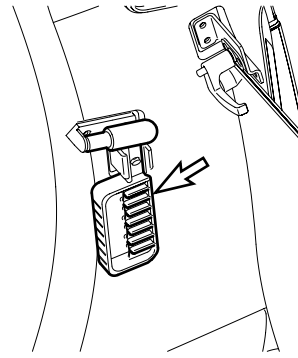

FG000178

Figure 13

In a work site where falling rocks can cause damage and possibly crush personnel, or in a mining operation, be sure to install the falling object protective structure (Figure 26).

Be sure to install any other additional protective structures required for work site conditions.

When the falling object protective structure is installed, and the front window needs to be cleaned, loosen the bolts marked with an arrow. Be sure to tighten bolts when done.

Operate Carefully on Snow, Ice and in Very Cold Temperatures

In icy cold weather avoid sudden travel movements and stay away from even slight slopes. The machine could skid off to one side very easily.

Snow accumulation could hide or obscure potential hazards. Use care while operating or while using the machine to clear snow.

Warming up the engine for a short period may be necessary, to avoid operating with sluggish or reduced working capacity. The jolting shocks and impact loads caused by bumping or bottoming the boom or attachment are more likely to cause severe stress in very cold temperatures. Reducing work cycle rate and workload may be necessary.

When the temperature rises, frozen road surfaces become soft, and machine travel becomes unstable.

In cold weather, do not touch metal surfaces with your bare hands. If you touch a metal surface in extremely cold weather, your skin may freeze to the metal surface.

Operations on Slopes

When working on slopes, there is a danger that machine may lose its balance and turn over, when swinging, or when work equipment is operated. Always carry out these operations carefully.

Do not swing the work equipment from the uphill side to the downhill side when the bucket is loaded. This operation is dangerous.

If the machine has to be used on a slope, pile the soil to make a platform that will keep the machine as horizontal as possible.

In addition, lower the bucket as far as possible, keep it pulled into the front, and keep the swing speed as low as possible.

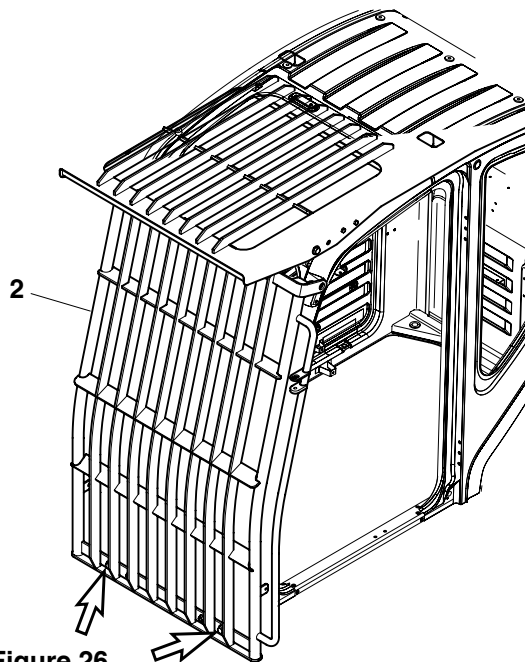

Figure 26

FG00011:

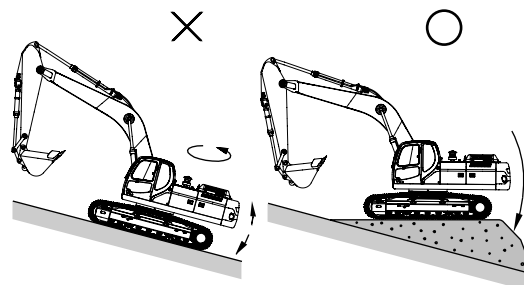

Figure 27

FG000212

Waste Materials

Physical contact with used motor oil may pose a health risk. Wipe oil from your hands promptly and wash off any remaining residue.

Used motor oil is an environmental contaminant and may only be disposed of at approved collection facilities. To prevent pollution of the environment, always do the following:

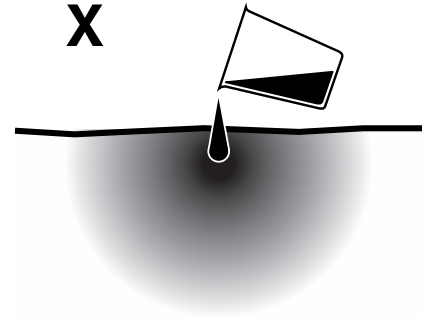

- Never dump waste oil in a sewer system, rivers, etc.
- Always put oil drained from your machine in containers. Never drain oil directly onto the ground.
- Obey appropriate laws and regulations when disposing of harmful materials such as oil, fuel, solvent, filters, and batteries.





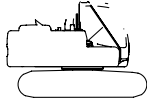











HAOA470L

Figure 44











TRACK WIDTH : 2.6 m (8' 6") STD TRACK
 BOOM : 4.6 m (15' 1") ONE-PIECE BOOM
 ARM : 3.0 m (9' 10")
 BUCKET : SAE 0.39 m³ (CECE 0.35 m³)
 SHOE : 600 mm (2')
 : RATING OVER FRONT
 : RATING OVER SIDE OR 360 degree
 UNIT : 1,000 kg (1,000 lb)

METRIC

A(m) \ B(m)	2		3		4		5		6		7		MAX. REACH			
															A(m)	
7														* 2.44	* 2.44	4.93
6							* 3.18	3.06						* 2.20	* 2.20	5.88
5							* 3.24	3.06	* 3.20	2.24				* 2.09	1.90	6.54
4					* 3.61	* 3.61	* 3.62	3.03	3.53	2.23				* 2.06	1.69	6.99
3			* 5.76	* 5.76	* 4.74	4.24	* 4.21	2.97	3.50	2.20	2.70	1.68		* 2.08	1.56	7.28
2					* 5.99	4.10	4.64	2.89	3.45	2.16	2.68	1.67		* 2.14	1.50	7.41
1					6.61	3.96	4.56	2.82	3.41	2.12	2.66	1.65		* 2.25	1.49	7.41
0 (GROUND)			* 5.12	* 5.12	6.51	3.87	4.50	2.76	3.37	2.09	2.64	1.63		* 2.43	1.53	7.27
-1			* 6.60	6.04	6.45	3.82	4.46	2.73	3.35	2.07				2.65	1.63	6.98
-2	* 5.23	* 5.23	* 9.26	6.05	6.44	3.82	4.45	2.72	3.35	2.06				2.95	1.83	6.52
-3	* 8.09	* 8.09	* 10.28	6.11	6.47	3.84	4.47	2.74						3.51	2.18	5.85
-4	* 12.22	* 12.22	* 8.69	6.21	* 6.48	3.91								* 4.70	2.91	4.88

FEET

A (ft) \ B (ft)	10'		15'		20'		MAX. REACH		
									A (ft)
25'							* 6.04	* 6.04	13' 6"
20'			* 6.63	* 6.63			* 4.89	* 4.89	19' 1"
15'			* 7.31	* 7.31	* 7.39	4.80	* 4.57	3.96	22' 2"
10'	* 12.29	* 12.29	* 9.61	7.56	7.51	4.73	* 4.57	3.46	23' 10"
5'			11.76	7.23	7.37	4.60	* 4.82	3.29	24' 5"
0 (GROUND)	* 11.99	* 11.99	11.46	6.97	7.25	4.49	* 5.35	3.38	23' 10"
-5'	* 17.92	12.97	11.34	6.86	7.19	4.44	6.14	3.79	22' 2"
-10'	* 22.20	13.12	11.39	6.91			7.86	4.87	19' 0"
-15'	* 15.54	13.52					* 10.27	8.47	13' 6"

1. LOAD POINT IS THE HOOK ON THE BACK OF THE BUCKET.
2. * RATED LOADS ARE BASED ON HYDRAULIC CAPACITY.
3. RATED LOADS DO NOT EXCEED 87 % OF HYD. CAPACITY OR 75 % OF TIPPING CAPACITY.

FG009528

Reference Number	Description
1	Counterweight
2	Muffler
3	Hood
4	Hydraulic Oil Tank
5	Fuel Tank
6	Engine
7	Fuel Tank Fill Cap
8	Radiator and Oil Cooler
9	Control Valves
10	Swing Motor
11	Air Cleaner
12	Swing Bearing
13	Seat
14	Cabin
15	Boom Cylinder
16	Work Lever (Joystick) Controls
17	Arm Cylinder
18	Boom
19	Travel Lever
20	Arm

Reference Number	Description
21	Bucket Cylinder
22	Guide Link
23	Bucket
24	Push Link
25	Tooth Point
26	Side Cutter
27	Idler
28	Track Adjuster
29	Track Guide
30	Battery
31	Lower Roller
32	Center Joint
33	Upper Roller
34	Travel Motor
35	Track Link and Shoe
36	Sprocket
37	Suction Filter
38	Return Filter
39	Pumps

9. Breaker / Boost / Shear Selector Switch

This switch is used to either select the breaker, power boost, or shear.

- O. In this position, a hydraulic pressure rise will be activated when pressing the button on the right-hand work lever (joystick).
- I. In this position, shear is activated.
- II. In this position, breaker is activated.

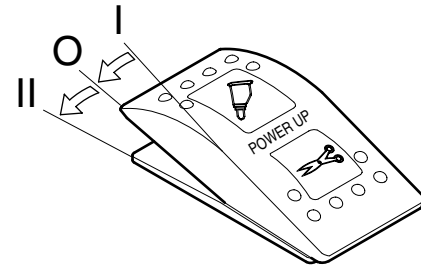

FG000025

Figure 16



WARNING!

Before using any attachment in a work application, be sure to check its functional control. Make sure that desired movement or action is being activated by the control. e.g. opening/closing, CW/CCW, crowd/dump, etc.

10. Cabin Work Light Switch (Optional)

This switch is used to control the cabin work lights, if unit is equipped with them.

- O. In this position, all cabin work lights are turned "OFF."
- I. In this position, the front cabin work lights on the front top of cabin will turn "ON."
- II. In this position, the front cabin work lights on the front top of cabin and rear cabin work lights on rear top of cabin will turn "ON."

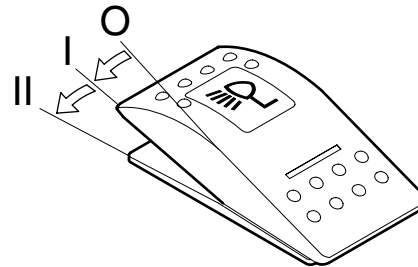

FG000026

Figure 17

11. Warning Light Switch (Optional)

If unit is equipped with a warning light, push this switch to activate it.

- O. In this position, the warning light is turned "OFF."
- I. In this position, the warning light turns "ON" and will start flashing.

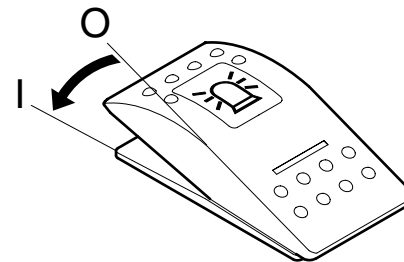

FG000027

Figure 18

Reference Number	Description
1	Fuel Gauge
2	Engine Coolant Temperature Gauge
3	Hydraulic Oil Temperature Gauge
4	Multifunction Gauge And Graphic Information Area (See page 2-31)
5	Digital Clock
6	Hour Meter
7	Charge Warning Light
8	Engine Oil Pressure Warning Light
9	Engine Coolant Temperature Warning Light
10	Engine Check Warning Light
11	Preheat Indicator Light

Reference Number	Description
12	Work Light Indicator Light
13	Power Mode Selector Button (See page 2-36)
14	Trenching Mode Selector Button (See page 2-37)
15	Auto Idle Selector Button (See page 2-37)
16	Flow Control Button (See page 2-37)
17	Up Arrow Button (See page 2-38)
18	Down Arrow Button (See page 2-39)
19	Display Selector Button (See page 2-39)
20	Selection Button (See page 2-39)

Functional Check

When the engine starter switch is turned to the "I" (ON) position, all gauge bands, switch/button indicator lights and indicator/warning lights will turn "ON" and the alarm buzzer will sound about two seconds.

During this functional check, a LOGO will appear on the multifunction gauge in the graphic information area (3 and 4, Figure 38).

Password Activated

If a password has already been set and the system has been "LOCKED," the password display will appear on the screen once the functional check has been completed. Enter the password into the text area and then engage the starter.

NOTE: Refer to "Set Password (Lock and Unlock)" on page 2-45, for further details.



If the password does not match the stored password, the engine will not start.

3. Fuel Shortage Warning

If the fuel quantity is too low, this symbol appears on the screen.

If this light turns "ON," add fuel as soon as possible.

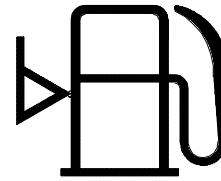

FG000057

Figure 62

4. Return Filter Clogged Warning

This symbol indicates when the hydraulic return filter is clogged.

If this symbol is displayed, immediately stop operation and replace the return filter.

After the return filter has been serviced, restart machine operation to remove warning symbol.

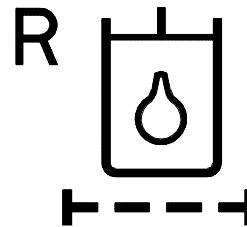

FG000054

Figure 63

5. Air Cleaner Clogged Warning

This symbol indicates when the air cleaner is clogged.

If this symbol is displayed, immediately stop operation and replace or clean the air filter.

After the air filter has been serviced, restart machine operation to remove warning symbol.

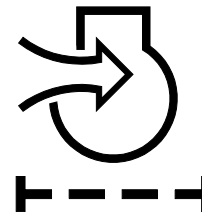

FG000053

Figure 64

Set Password (Lock and Unlock)

Use extreme care when setting the password for starting the engine. If a mistake is made when entering the number, and the number is excepted by the system, as being correct, that number will be the only one that will allow the security system to be activated or deactivated.

Write your password down and keep it in a safe location.

Password numbers can only use numbers between 1 and 8. The small number to the lower left of each button on the instrument panel, indicates the number that will be entered when that button is pressed. Numbers "0" and "9" are invalid choices.

Example:

2785 is acceptable.

9024 is not acceptable.

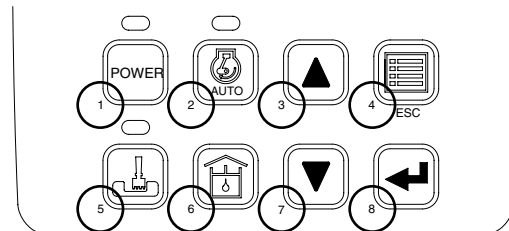

HAAE2010

Figure 90

When the cursor is on "Set Password" press the "SELECT" (↵) button. The set password submenu will appear.

NOTE: The screen can be returned to the main menu by pressing the "ESC" (☰) button (3, Figure 72).

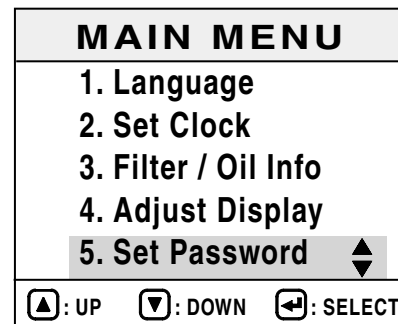

FG000227

Figure 91

Password inquiry menu will be displayed.

NOTE: The initial password is "1111."

The password can be changed within ten minutes while the starter switch is in "I" (ON) position.

After changing password, be sure to use the changed password.

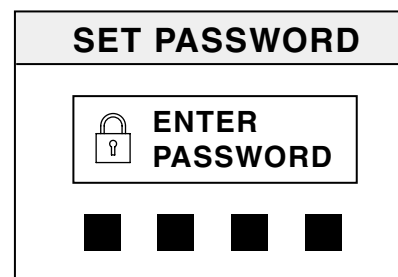

FG000228

Figure 92

CAUTION!

Failure to enter correct password three times, will return normal display screen, and another attempt will not be possible for ten minutes.

- D. Used to direct airflow to the front window and to operator's feet.

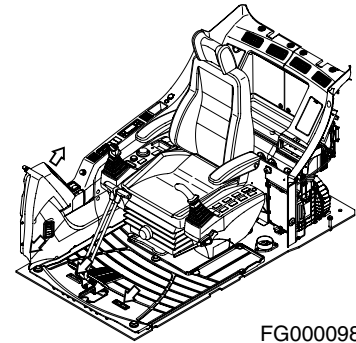

FG000098

Figure 115

6. Air Inlet Selector Button

This button is used to select fresh air from outside the cabin, or recirculate air within the cabin.

Pressing this switch enables the choice between fresh air and recirculating air within the operator's cabin. The select mode is displayed on the LCD.



FG000101

Figure 116

- A. "A" Symbol - Draws fresh air into operator's cabin. Used to exchange air within the operator's cabin with fresh air. Used to remove condensation or ice on window (Winter / Rainy Season).
- B. "B" Symbol - Recirculates air within the operator's cabin. Used to quickly warm or cool the operator's cabin.

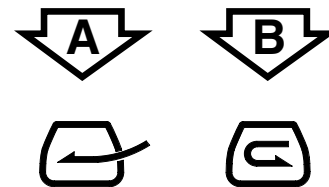

FG000102

Figure 117

7. Fan Speed Selector Buttons

These buttons are used to control the speed of the blower fan.

Momentarily, pressing a button, changes the speed one stage.

Continuously pressing and holding a button, repeatedly changes the speed.

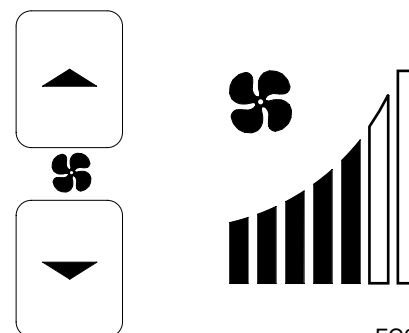

FG000103

Figure 118

CEILING COVER

NOTE: *If the machine is equipped with the optional transparent ceiling cover never use any chemical cleaners on its surface. Only use warm water to wash dust and dirt from its surfaces, and after that, dry it with a soft fabric towel.*

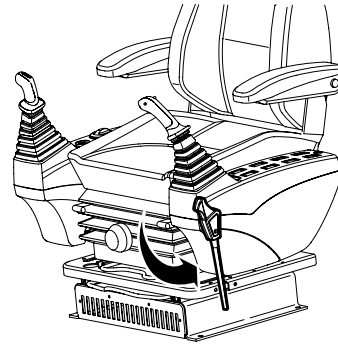

FG000189

Figure 136

Opening the Ceiling Cover

1. Lower bucket to ground.
2. Set safety lever (Figure 136) on "LOCK."
3. Pull the lock (1, Figure 137) in front center of ceiling cover and push it up with handle.

Closing the Ceiling Cover

1. Lower bucket to ground.
2. Set safety lever (Figure 136) on "LOCK."
3. Pull down cover with the handle (Figure 137) so the lock (1) can be locked in the bracket in the ceiling frame.

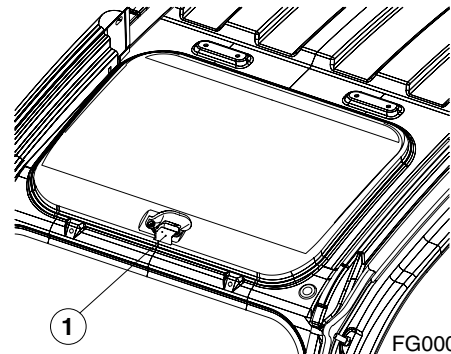

FG000190

Figure 137

Operational Checks Before Starting Engine



When leaving operator's seat, set the safety lever to "LOCK" (Figure 1) position, if not a serious accident could occur by accidentally moving the travel or work levers.

1. Set safety lever on "LOCK" (Figure 1).
2. Fasten seat belt. Check for proper operation and condition.
3. Set all operation levers in "NEUTRAL."

NOTE: *Be careful not to touch any switches when starting engine.*

4. Rotate the starter switch to the "I" (ON) position (Figure 2). Check all indicator lights. A warning buzzer will sound for about two seconds. After two seconds, all lights except the following will turn "OFF."

- Charging warning light
- Engine oil pressure warning light
- Engine coolant temperature gauge
- Fuel gauge
- Hydraulic oil temperature gauge
- Engine rpm (0 rpm) digital readout

NOTE: *If all the indicator lights do not come "ON" when the key is first turned, there is a problem.*

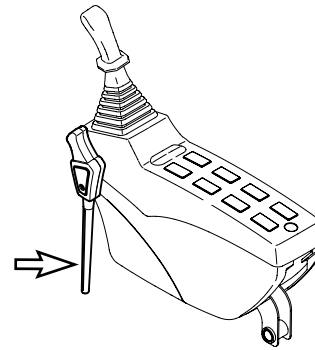

FG000211

Figure 1

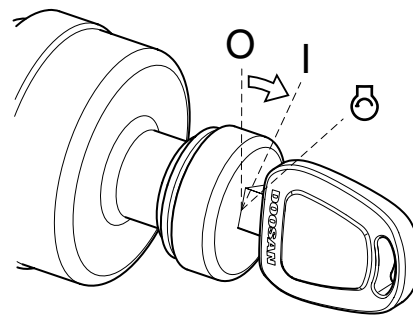

FG000084

Figure 2

CLICK HERE TO **DOWNLOAD** THE COMPLETE MANUAL

- Thank you very much for reading the preview of the manual.
- You can download the complete manual from: www.heydownloads.com by clicking the link below



- Please note: If there is no response to CLICKING the link, please download this PDF first and then click on it.

CLICK HERE TO **DOWNLOAD** THE COMPLETE MANUAL

SAFETY LEVER

WARNING!

When stopping engine or leaving the operator's seat, "LOCK" the safety lever, otherwise, a serious accident may occur by accidental movement of travel and work levers.

Whenever leaving the operator's seat, make sure the engine is shut down and the safety lever is "LOCKED."

Especially, when adjusting the seat, control stands, or raising the front window, lower window, or ceiling cover, never forget to lock the safety lever in its "LOCKED" position.

Be careful not to move the work levers (joysticks) when moving safety lever.

1. Push safety lever (Figure 25) down into the "LOCKED" position. When safety lever is in the "LOCKED" position, the front attachment, swing and travel movement will be disabled even though a lever is moved.

NOTE: Lower bucket (front attachment) to ground. Place all control levers in "NEUTRAL" and shut down engine, before using the safety lever.

2. Set safety lever (Figure 25) on "RELEASE/UNLOCK" position, by pulling it up before starting work.

NOTE: When the engine is not running, but the safety lever is "RELEASED" and the starter key is tuned "ON," moving the work levers (joysticks) may result in movement. The charged accumulators in the system will provide pilot pressure for control valve spool movement.

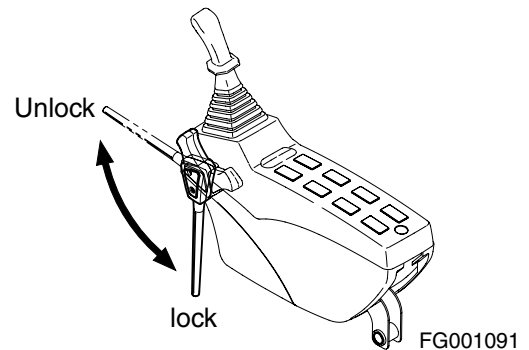

Figure 25

Work Levers (Joysticks) (ISO Style)



Check surrounding area before swinging. When operating a lever while in auto idle, do it carefully, because the engine speed will increase rapidly.

NOTE: When starting work, move work levers (joysticks) slowly and check movement of swing and front attachment.

This equipment is manufactured using the lever configuration described in ISO standards. Do not change valving, hoses, etc., that would change this standard. The boom, arm and bucket movements and swing direction of work levers (joysticks) are as follows:

Left-hand Work Lever (Joystick) (Figure 44 and Figure 45)

1. Arm dump
2. Arm crowd
3. Left swing
4. Right swing

NOTE: The swing brake is spring applied and hydraulically released. It is always engaged when the work lever (joystick) is in "NEUTRAL" or the engine is shut down.

NOTE: The following is not a mechanical malfunction but a proper phenomenon of the excavator. When operating the arm, it may stop momentarily. When the arm is operated, the weight of the arm may cause it to move faster than the amount of oil being supplied.

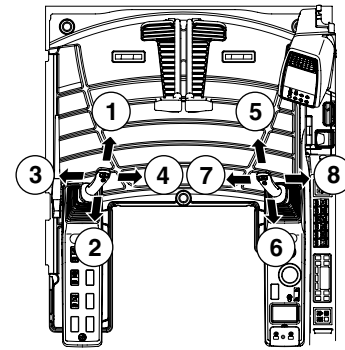

FG000381

Figure 44

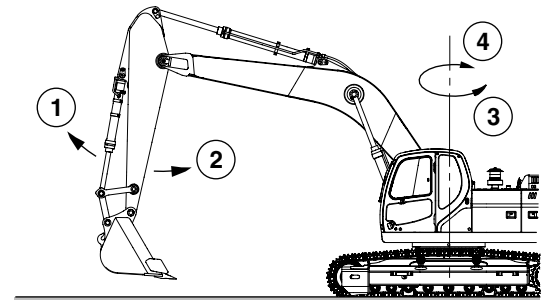

FG000119

Figure 45

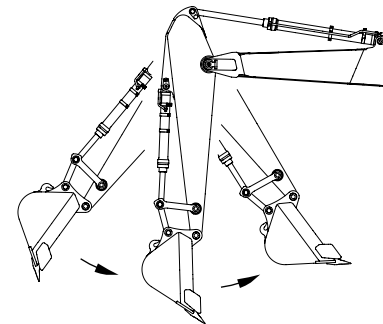

FG000120

Figure 46

TOWING PROCEDURE

WARNING!

Never use a damaged wire rope or chain. They could brake and cause a serious accident.

Always wear gloves when handling a chain or wire rope.

When towing excavator use a wire rope or chain capable of handling the load.

Attach chain or wire rope to track frame as shown in Figure 75

Insert protective material such as thick cloths between track frame and wire rope to prevent the wire rope from being damage.

IMPORTANT

Use shackle hook on track frame to only haul objects that weigh less than 7 metric tons (7.71 U.S. Tons). Never use it to haul objects over 7 metric tons (7.71 U.S. Tons).

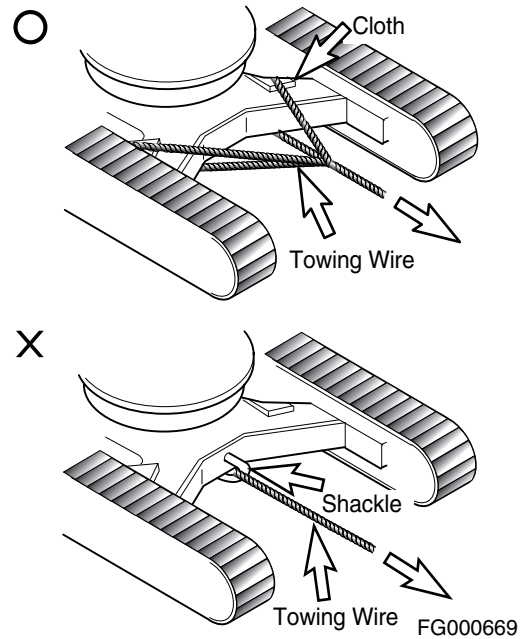

Figure 75



DANGER!

If a load is picked up from the front zone and swung into the side zone, a tip over could result causing a deadly or fatal injury.

Lifting Known Weight

The load chart is the governing factor when lifting known weights. It is recommended that you feel your way into any lift as a precaution against tip over. Whenever possible, lift and swing payloads between the front idler area.

Pick and Carry

The machine can pick and carry payloads without added labor. We recommend when traveling with a suspended payload, you evaluate the prevailing conditions and determine the safety precautions required in each case. The following factors must be considered before attempting to pick and carry a load.

Align the boom with the forward direction of machine travel. Maintain this boom position when turning the machine. Turn only when necessary, at the slowest speed, and at a wide turning radius.

1. Use the shortest lifting radius distance possible.
2. Keep the load as close to the ground as conditions will permit.
3. Provide tag lines to prevent load from pendulating. Pendulating can cause a change in radius. A change in radius could exceed the load chart rating or cause a tip over condition.
4. Govern travel speed to suit conditions.
5. Avoid sudden starts and stops.

5. Shut down engine by turning key to "O" (OFF) position. Remove key from starter switch.



WARNING!

If engine must be run while performing maintenance, use extreme care. Always have one person in the cabin at all times. Never leave the cabin with the engine running.

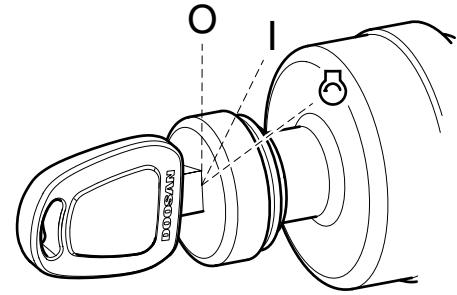

FG000175

Figure 9

6. Before starting maintenance work, hang up a tag, "Do Not Touch When Performing Inspection or Maintenance" on cabin door or work lever.

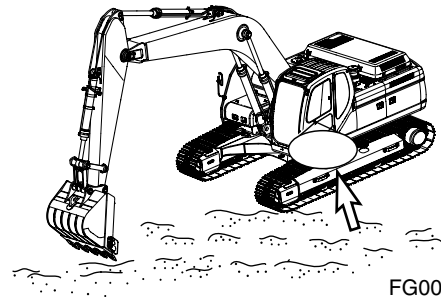

FG000401

Figure 10

Check Engine Oil Level



Allow the engine to cool before checking the oil level to avoid burns by touching hot engine parts.

NOTE: When checking level using a dipstick always remove and wipe it clean before making final level check.

1. Shut down engine and wait for fifteen minutes. This will allow all oil to drain back to oil pan.
2. Remove dipstick (1, Figure 14) and wipe the oil off with a clean cloth.
3. Insert dipstick fully in the oil gauge tube, then take it out again.
4. Engine oil level must be between "HIGH" and "LOW" marks on dipstick.

NOTE: If oil is above "HIGH" mark on dipstick, some must be drained to return oil to proper level.

5. Add oil through engine oil fill cap (2, Figure 14), if the oil level is below the "LOW" mark.

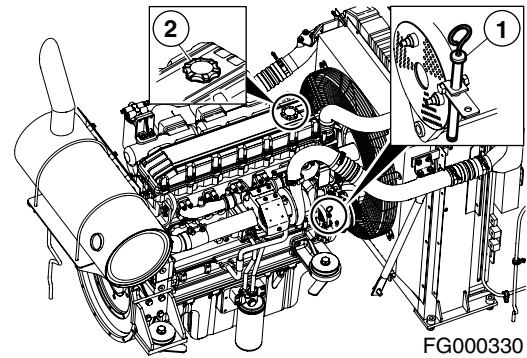
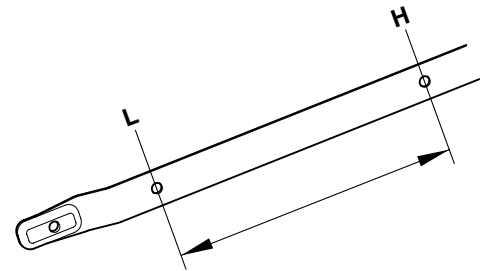

Figure 14



FG000616

Figure 15

Check Level of Hydraulic Oil Tank



The hydraulic oil will be hot after normal machine operation. Allow the system to cool before attempting to service any of the hydraulic components.

The hydraulic tank is pressurized. Turn the breather cap slowly to allow the pressurized air to vent. After the pressure has been released, it is safe to remove either the fill cap or service covers.



ARO1760L

Figure 16

50 HOUR / WEEKLY SERVICE

Perform All 10 Service Checks

Grease Arm and Front Attachment Pins

Grease every 10 hours for first 100 hours and every 50 hours thereafter.

NOTE: *If the unit has been running or working in water the front attachment should be greased on a 10 hour / daily basis.*

- Position machine as shown below and lower the front attachment to the ground and shut down engine
- Press the grease fitting and inject grease with the grease gun on the marked point
- After injection, clean off the old grease that has been purged.

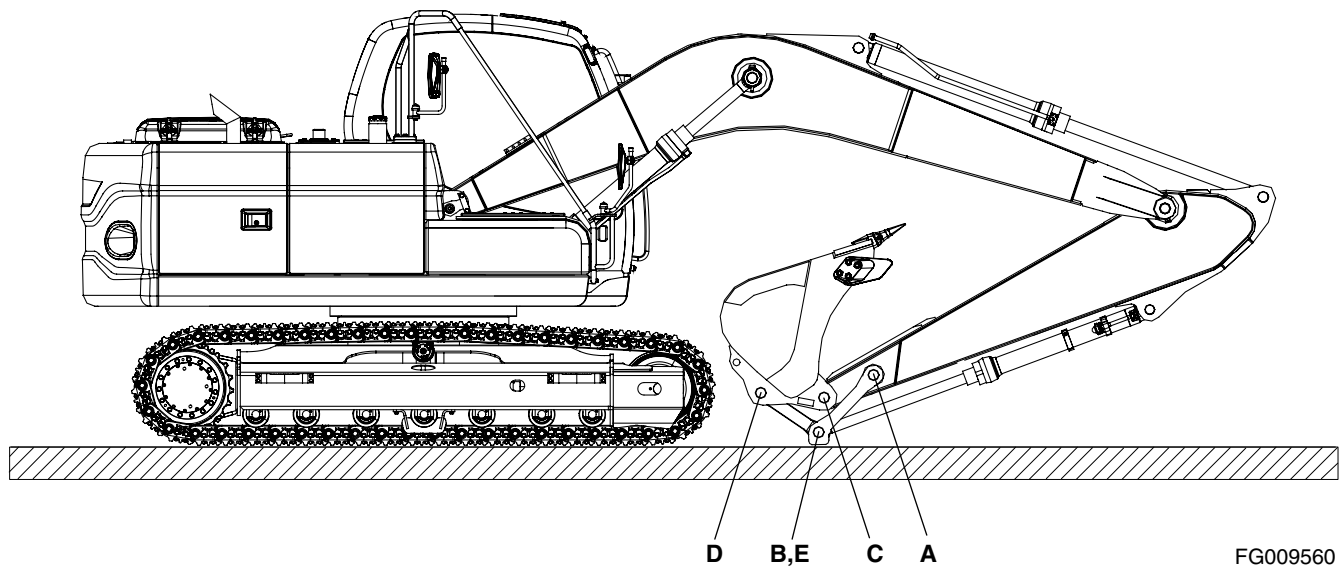

Figure 35

Reference Number	Description
A	Arm Link Joint Pin (1 Points)
B	Link Joint Pin (2 Points)
C	Arm Bucket Joint Pin (1 Points)

Reference Number	Description
D	Bucket Link Joint Pin (1 Point)
E	Bucket Cylinder Rod Pin (1 Point)

500 HOUR / 3 MONTH SERVICE

Perform All 10, 50 and 250 Hour Service Checks

Grease Swing Gear and Pinion



Greasing swing gear and pinion must be serviced by only one person.

1. Remove inspection cover and inspect the condition of the grease. Make sure that water or other contaminants are not noticeable.

NOTE: *The upper structure must be rotated a little at a time so the entire face of the swing gear can be lubricated. Use extreme caution when performing this operation.*

2. If water or other contaminations are found, remove lower access cover so the gear teeth can be thoroughly cleaned and lubricated.
3. Install access covers after lubricating gear teeth.

Change Engine Oil and Filter

NOTE: *Change engine oil and filter after first 50 hours of operation or rebuild, then every 500 thereafter.*



DO NOT change oil on a hot engine. Allow the engine to cool down before attempting to change the engine oil and filter to avoid burns by touching hot engine parts.

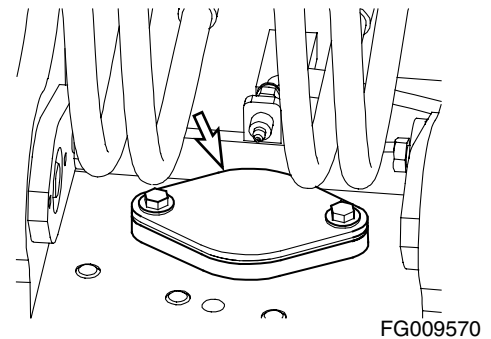

Figure 50

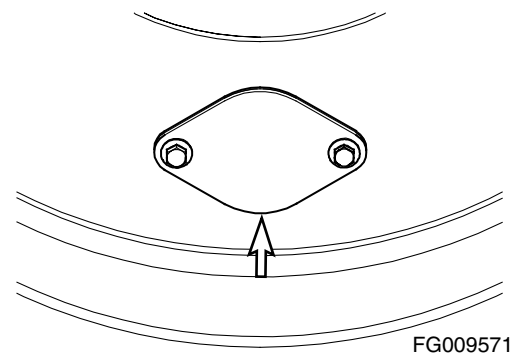
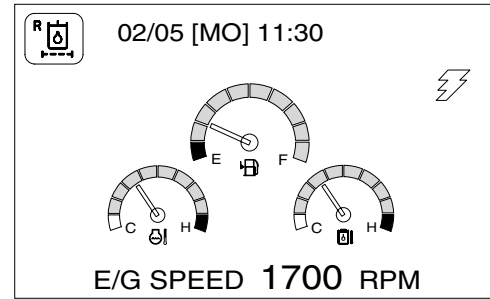

Figure 51

Replace Hydraulic Oil Return Filter

NOTE: Change hydraulic oil return filter after first 250 hours of operation or rebuild, and every 1,000 hours thereafter.

NOTE: If return filter clogged warning light (Figure 75) on instrument panel comes "ON" the return filter must be serviced.



FG000760

Figure 75

WARNING!

The hydraulic oil will be hot after normal machine operation. Allow the system to cool before attempting to service any of the hydraulic components.

The hydraulic tank is pressurized. Loosen the hydraulic breather cap slightly to allow the pressurized air to vent. After the pressure has been released, it is safe to remove either the fill cap or service covers or drain water from the tank.

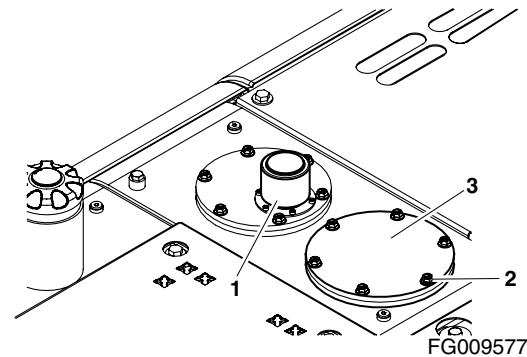

FG009577

Figure 76

IMPORTANT

Make sure to clean any dirt or water from the top of the hydraulic tank, especially around the fill port and filter ports.

1. Park machine on firm, level ground. Lower the front attachment to the ground and shut down engine.
2. Loosen the breather cap (1, Figure 76) slightly to release the internal pressure.
3. Remove bolts (2, Figure 76) and service cover (3). Remove spring (4), valve (5) O-ring (6), and bypass strainer (7), and then filter (8).

4. Remove filter and discard.

NOTE: Used filter should always be disposed of according to local regulations.

5. Install new filter and a new O-ring. Install bypass strainer, valve and spring. Install service cover plate.
6. Tighten the breather cap (1, Figure 76).
7. Run engine for ten minutes at low idle to purge air from circuit.
8. Check level in hydraulic oil tank (See page 4-15). Add oil if necessary.

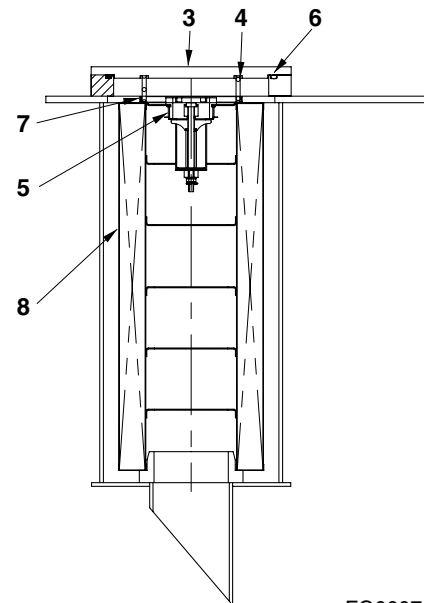

FG000761

Figure 77

10. Fill the hydraulic oil tank. Check level using sight gauge on side of tank.
11. Place spring (3, Figure 100) on rod (4) and assemble cover (2).
12. After replacing and cleaning the hydraulic oil, filter and strainer, vent the system. See "Venting and Priming Hydraulic System" on page 4-84.

IMPORTANT

When the hydraulic breaker is being used, because of the higher heat generated by this unit, use replacement intervals recommended under the "Hydraulic Oil and Filter Service Intervals" on page 3-38.

13. Check level of hydraulic oil tank. (See page 4-15)

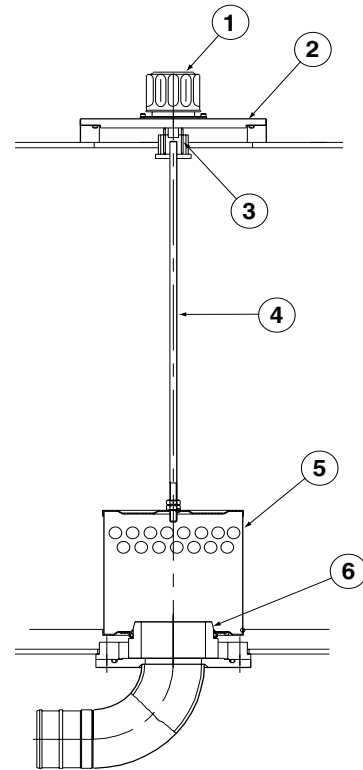

Figure 100

ARO1720L

Check Alternator and Starter**

**These checks need to be completed by an authorized DOOSAN dealer.

Check All Rubber Antivibration Shock Mounts

Perform and Record the Results of the Cycle Time Tests

Inspect Machine to Check for Cracked or Broken Welds or other Structural Damage

Check, Adjust Valve Clearance **

Check Head Bolt Torques

16. Tightening bolt for track guard

- Tool: 24 mm (🔧)
- Torque: 27 kg•m (264 Nm, 195 ft lb)

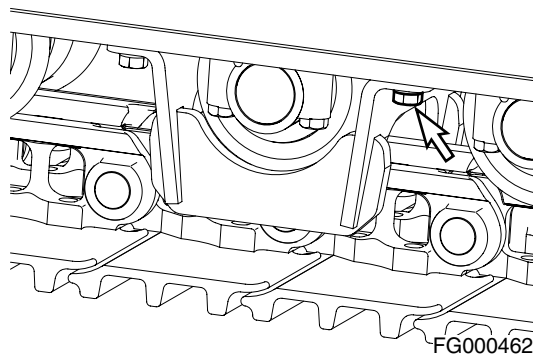

Figure 121

17. Bolt for track shoes

- Tool: 24 mm (🔧)
- Torque: 39 kg•m (382 Nm, 282 ft lb)

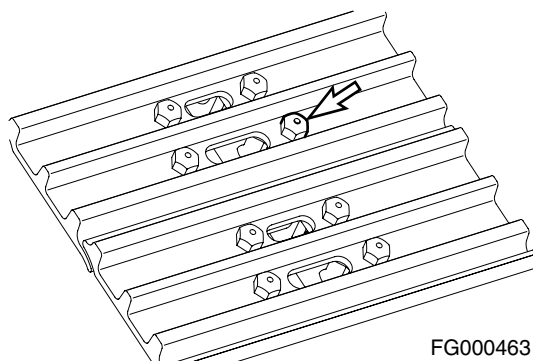

Figure 122

18. Fixing bolt for front pin

- Tool: 24 mm (🔧)
- Torque: 27 kg•m (264 Nm, 195 ft lb)

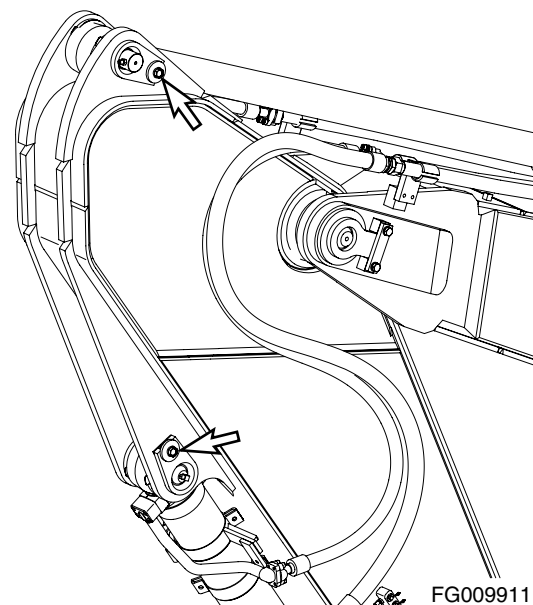

Figure 123



WARNING!

Pressure at air nozzle must not exceed 2.1 kg·cm² (30 psi). Always wear goggles when using compressed air.

Do not pour cold water into radiator when engine is very hot and water level is below the top of the tubes. Such action could result in damage to engine cylinder heads.

Heavy-duty diesel engines require a balanced mixture of water and antifreeze. Drain and replace the mixture every year or 2,000 hours of operation, whichever comes first. This will eliminate buildup of harmful chemicals.

Antifreeze is essential in any climate. It broadens the operating temperature range by lowering the coolant's freezing point and by raising its boiling point. Do not use more than 50% antifreeze in the mixture unless additional freeze protection is required. Never use more than 68% antifreeze under any condition.

Measuring the Concentration of Coolant

The coolant and its additives can be checked by using coolant test strips (No: 60.99901-0038). Use the following procedure to conduct the test:

1. With a coolant temperature of 10° - 55°C (50° - 131°F), drain 1 liter (1 U.S. quart) of it from the radiator into a clean plastic container.

NOTE: *Do not take the sample from the coolant recovery tank. Recovery tank coolant concentration can differ from the concentration level of coolant in the radiator.*

2. Dip test strip, into coolant sample for 3 - 5 seconds. Remove strip and excessive coolant by giving the strip one shake.
3. Wait for 45 seconds, for the test strip to change color.

NOTE: *Measuring time should not be more than 75 seconds. If it is over this time limit, the color will be changed and an inaccurate reading will result.*

4. Compare the color of the test strip with the color table on the outside of test strip container bottle, and determine what numeric value corresponds to the color in the table.
 - A. Check antifreeze concentration levels by comparing the color change at the end of test paper, with the green spectrum range, with the green symbol on the upper portion of the container bottle.

NOTE: *A suitable concentration indicator should be between 33% and 50%.*

Swing Motor

IMPORTANT

If the air is not vented from the system, it will cause damage to the swing motor and bearings.

NOTE: Perform this only when oil has been drained from swing motor.

1. Shut down engine.
2. Disconnect drain hose and fill swing motor case with hydraulic oil.
3. Connect the drain hose.
4. Start engine and set throttle at "LOW IDLE" and swing upper structure slowly two full revolutions to the left and right.

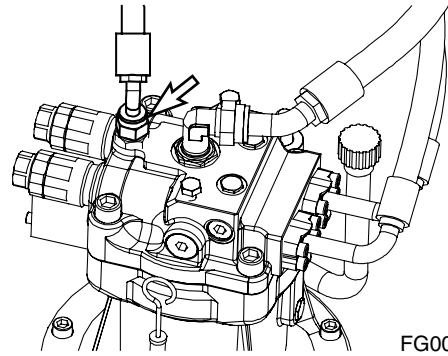

FG009596

Figure 144

Travel Motor

NOTE: Perform this only when oil is drained from travel motor

1. Shut down engine
2. Disconnect drain hose (Figure 145) and fill motor case with hydraulic oil.
3. Connect drain hose.
4. Start engine and set engine speed control dial to "LOW IDLE." Run the engine for one minute and slowly drive excavator forwards and backwards.

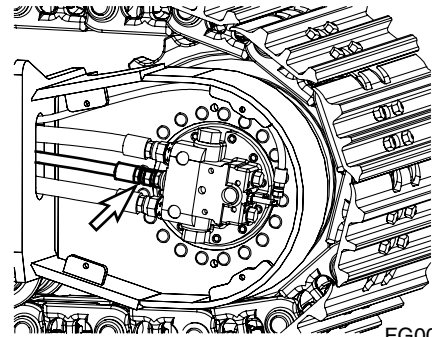

FG009597

Figure 145

General Venting

1. After venting air from all components, shut the engine down and check the hydraulic oil level. Fill hydraulic oil tank to "H" mark on sight gauge.
2. Start engine and operate all controls again, run engine for five minutes to ensure all systems have been vent and purged of air. Set engine speed to "LOW IDLE," and check hydraulic oil level again. Add oil as necessary.
3. Check for oil leaks and clean all fill and venting locations.

Troubleshooting

Anytime that a malfunction occurs, take immediate corrective action. Check for and investigate the cause of the malfunction. A schedule maintenance program can prevent malfunctions from occurring by doing preventative maintenance. A systematic approach should be taken to troubleshooting, since several overlapping malfunctions may give the appearance of a problem that does not exist. If cause for the malfunction cannot be determined, contact your *DOOSAN* distributor. Never perform an adjustment of or disassembly of, hydraulic components, electrical and electronic components, without first consulting a *DOOSAN* distributor.

ELECTRICAL SYSTEM

Problem	Possible Cause	Remedy
Battery will not hold a charge.	Low battery power.	Clean and retighten.
	Alternator belt loose or bad.	Tighten or replace belt.
	Loose or corroded terminals.	Tighten or replace as required.
	Alternator faulty.	Repair or replace as required.
Low battery power.	Internal battery short.	Replace battery.
	Short-circuit in wiring.	Repair as required.
Engine speed is not controllable.	Speed control dial failed.	Replace control dial.
	Throttle controller failed.	Replace controller.
	Speed control motor failed.	Repair or replace as required.
	Blown fuse.	Replace fuse.
	Wiring harness damaged.	Repair or replace as required.
	Connector failed.	Repair or replace as required.
Power mode selector does not work.	Blown fuse.	Replace fuse.
	Power mode selector switch failed.	Replace switch.
	Connector failed.	Replace connector.
	Wiring harness damaged.	Repair or replace as required.
	e-EPOS controller failed.	Repair or replace as required.

Two - Piece Boom

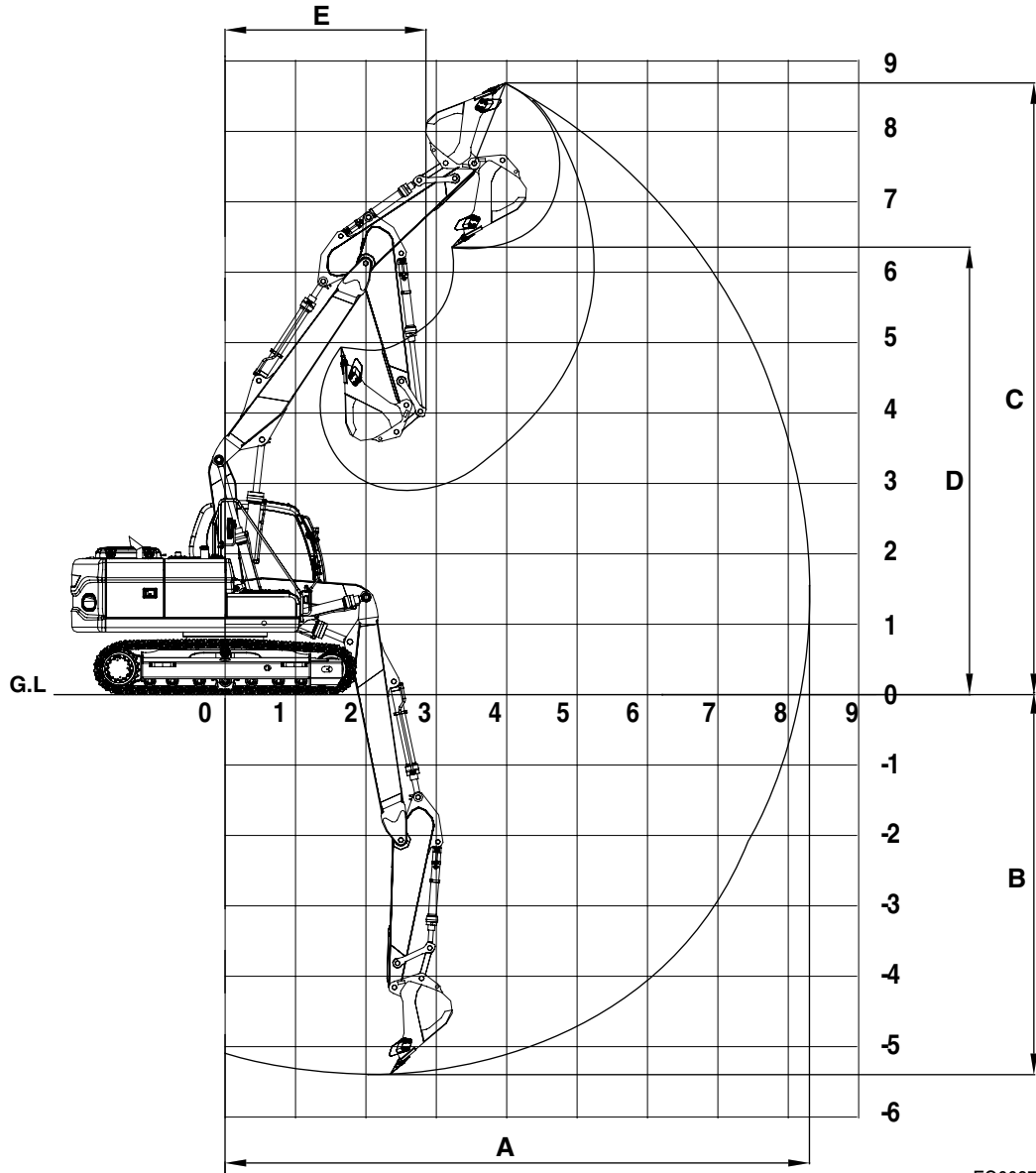

FG009725

Figure 3

DIM.		4.98 m (16' 4") Two - Piece BOOM	
		2.1 m (6' 11") Arm	2.5 m (8' 2") Arm
A	Max. Digging Reach	8,380 mm (27' 6")	8,805 mm (28' 11")
B	Max. Digging Depth	5,440 mm (17' 10")	5,850 mm (19' 2")
C	Max. Digging Height	8,820 mm (28' 11")	9,235 mm (30' 4")
D	Max. Loading Height	6,420 mm (21' 1")	6,810 mm (22' 4")
E	Min. Swing Radius	2,925 mm (9' 7")	2,935 mm (9' 8")

CLICK HERE TO **DOWNLOAD** THE COMPLETE MANUAL

- Thank you very much for reading the preview of the manual.
- You can download the complete manual from: www.heydownloads.com by clicking the link below



- Please note: If there is no response to CLICKING the link, please download this PDF first and then click on it.

CLICK HERE TO **DOWNLOAD** THE COMPLETE MANUAL