

***DOOSAN***

950106-01251 NA-2  
January 2015

WHEEL LOADER

**Operation &  
Maintenance  
Manual**

**DL250-5/DL250TC-5**

**Serial Number 10001 and Up**

CLICK HERE TO **DOWNLOAD** THE COMPLETE MANUAL

- Thank you very much for reading the preview of the manual.
- You can download the complete manual from: [www.heydownloads.com](http://www.heydownloads.com) by clicking the link below



- Please note: If there is no response to CLICKING the link, please download this PDF first and then click on it.

CLICK HERE TO **DOWNLOAD** THE COMPLETE MANUAL

## Other Signal Words

In addition to safety signal words, the following signal words are used to indicate proper and effective use of machine.

---

# IMPORTANT

---

**This signal word identifies procedures which must be followed to avoid damage to machine.**

---

**NOTE:** *The word "NOTE" identifies information for effective use.*

## AEM SAFETY MANUAL (NORTH AMERICA ONLY)

The AEM Safety Manual delivered with the machine gives general safety information.

The AEM Safety Manual must be read and understood before beginning operation or maintenance and is not intended to replace the Operation & Maintenance Manual delivered with the machine.



FG020060

Figure 1

## Safety Decal

### 1. General Hazard (950205-04644A)

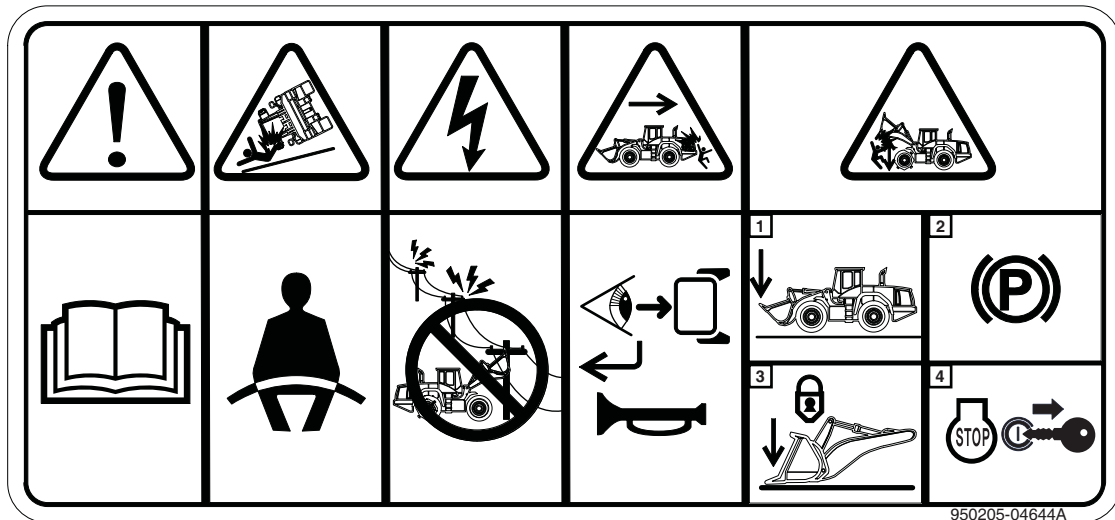

WL1400812

## WARNING

### AVOID DEATH OR SERIOUS INJURY

- Never use wheel loader without instructions.
- Read Operation & Maintenance Manual before operation.
- Always fasten your seat belt.
- Explosion or electrocution can occur if machine contacts utility lines or pipes. Check for overhead or underground lines before operating.
- Keep bystanders out of travel path and always look in the direction of travel.
- Ensure mirrors and rear view camera are clean and working properly.
- Sound the horn to alert bystanders before operating
- Never operate machine from outside the operator's position.
- TO LEAVE THE WHEEL LOADER:
  - 1) Lower the attachment to the ground and make sure all controls are in neutral.
  - 2) Engage the parking brake.
  - 3) Set pilot cutoff switch to OFF position.
  - 4) Stop the engine and remove the key.

## Flying or Falling Objects

On work sites where there is a potential hazard that flying or falling objects can come in contact with operator's cabin, select and use a guard to match operating conditions for additional operator protection.

Working in mines, tunnels, deep pits, and loose or wet surfaces, can produce hazards of falling rocks or flying objects. Additional protection for operator's cabin could be required such as an Operator Protection Guard (OPG) or window guards. Contact your DOOSAN distributor for information on available protective guards.

To prevent personnel from being struck by flying objects, keep personnel out of work area.

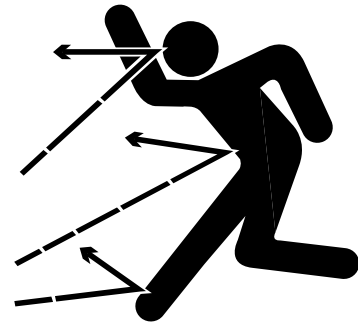

HAOA110L

Figure 4



HAOA100L

Figure 5

## Personal Protective Equipment (PPE)

Do not wear loose clothing and accessories. Secure long hair. These items can snag on controls or on other parts of equipment.

Do not wear oily clothes. They are highly flammable.

Do not forget that some risks to your health may not be immediately apparent. Exhaust gases and noise pollution may not be visible, but these hazards can cause disabling or permanent injuries. Breathing masks and/or ear protection may be required.

Wear a hard hat, safety shoes, safety goggles, mask, leather gloves, earplugs and other protective equipment, as required.

While working on machine, never use inadequate tools. They could break or slip, or they may not adequately perform intended functions.

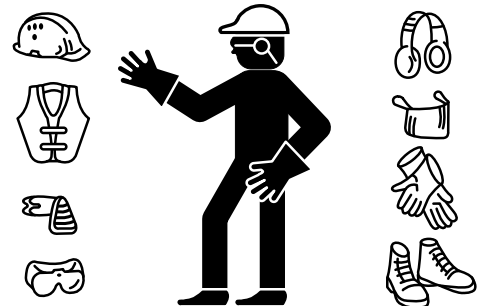

HAOA020L

Figure 6

Know appropriate work site hand signals and personnel that are authorized to give hand signals. Follow hand signals from only one person.

If you need to operate on a street, protect pedestrians and cars by designating a person for work site traffic duty or by erecting fences and posting "No Entry" signs around work site.

Erect barricades or fences, post "No Entry" signs, and take other steps to prevent people from coming close to or entering work site. If people come too close to a moving machine, they may be struck or caught by machine, and this can result in death or serious injury.

## Check Tire Pressure and Condition

Maintain tire pressure but do not overinflate. Inspect tires and wheels daily. When inflating tires, follow procedures in Maintenance Section, which include using an extension to avoid standing in front of or over a tire. Do not change a tire unless you understand proper tire maintenance procedures and are using proper equipment.

Refer to "Recommended Air Pressure" on page 4-109.

## Mounting/Dismounting

Before getting on or off machine, if there is any oil, grease, or mud on handrails or steps, wipe it off immediately. Always keep these parts clean. Repair any damage and tighten any loose bolts.

Never jump on or off machine. In particular, never get on or off a moving machine. These actions can result in death or serious injury.

When getting on or off machine, always face machine. Maintain a three-point contact (both feet and one hand or one foot and both hands) with handrails and steps to ensure that you support yourself securely.

Never hold onto any control levers when getting on or off machine.

Securely latch door. If you grip handrail inside door when moving on platform outside of door, and door latch is not securely engaged, door may move and cause you to fall resulting in death or serious injury.

Use points marked by arrows in diagram when getting on or off machine.

Do not carry tools or supplies when you mount or dismount the machine.

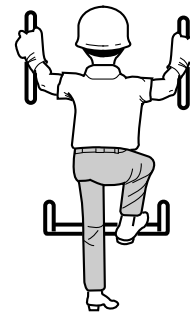
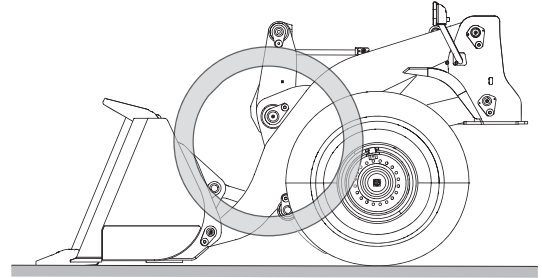

Figure 20

HA3O1003

2. When stopping or parking machine, lower front structure to ground. If this is not done, sudden collapse of front structure caused from a hydraulic hose failure can result in death or serious injury.



WL1400123

Figure 27

3. When repairing or inspecting machine, with front structure raised in air, firmly support front structure. When installing supporting structure, check that it is rated and approved to support the weight of the structure.

High-pressure loads between lift arm structure and support can cause support to slip, causing boom to collapse, leading to death or serious injury. Always install the supporting structure on firm and level ground.

A supporting structure must be used, when disconnecting front hoses or removing any other mechanical component related to front structure. High-pressure oil can be ejected from front hydraulic cylinder that can cause the lift arm to suddenly lower or attachment movement resulting in death or serious injury.



## WARNING

---

### AVOID DEATH OR SERIOUS INJURY

**Pressurized oil has enough force to pierce skin and cause death or serious injury.**

**If fluid enters skin or eyes, get immediate medical attention from a physician familiar with this injury.**

---

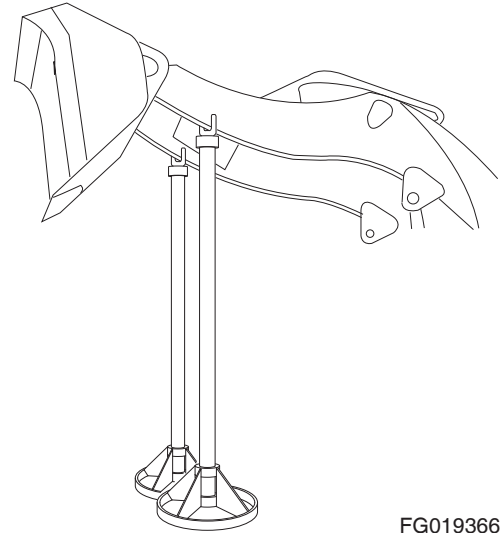

FG019366

Figure 28

# IMPORTANT

---

**When disconnecting or connecting connectors between ECU/DCU and engine, or connector between ECU/DCU and the machine, always disconnect the battery to prevent damage to ECU/DCU.**

**If you do not follow this procedure, the ECU/DCU will be damaged and/or the engine will not operate properly.**

---

When performing welding repairs, perform welding in a properly equipped and well ventilated area. Repairs should only be performed by a qualified welder. Welding operations, can create potential hazards, including generation of gas, fire, or electric shock. Never let an unqualified welder do welding.

A qualified welder must do the following:

- To prevent battery explosion, turn battery disconnect switch to "OFF" position.
- Disconnect the connector between ECU/DCU and machine, and the connector between ECU/DCU and engine.
- To prevent generation of gas, remove paint from location of the weld.
- If hydraulic equipment, piping or component ports close to them are heated, a flammable gas or mist could cause an explosion or fire. To prevent this, protect and insulate components from excessive heat.
- Do not weld on pipes or on tubes that contain flammable fluids. Do not flame cut pipes or tubes that contain flammable fluids. Before welding on pipes or tubes, or before flaming cut pipes or tubes, clean them thoroughly with a nonflammable solvent. Make sure pressure inside pipes or tubes does not cause a rupture of the component parts.
- If heat is applied directly to rubber hoses or piping under pressure, they may suddenly break, so cover and insulate them with a fireproof covering.
- Wear protective clothing.
- Make sure there is good ventilation.
- Remove all flammable objects and make sure a fire extinguisher is available for immediate use.

## Poor Visibility

For good visibility, always do the following:

- When working in dark areas, attach working lights and front lights to the machine. If necessary, set up additional lighting at work site.
- Stop operations when visibility is poor, such as in fog, mist, snow, and rain. Wait for visibility to improve before starting operation.

To avoid hitting work equipment and damaging other property, always do the following:

- When working in tunnels, on bridges, under electrical wires, or when parking the machine or performing other operations in places with limited height, be careful not to hit and damage other equipment or property.
- To prevent hitting objects, operate machine at a slow speed when working in confined spaces, indoors, or in crowded areas.
- Do not move bucket over the top of personnel or bystander or over operator's cabin of dump truck or other machines.

## Loose or Soft Ground

Do not operate on soft ground or near edge of drop-offs, overhangs, or deep ditches. The ground can collapse because of the weight of the machine, causing the machine to fall or rollover.

Check ground conditions before beginning work with the machine. If ground is soft, reposition the machine before operating.

The excavated material must not be dumped too close to edge. The distance from an edge of an excavation where the excavated material must be dumped depends on soil type and moisture content. If loose clay is being excavated, place it at least 5 m (16 ft) away from edge.

If excavated material is dumped too close to edge, its weight can cause a landslide.

Thawing of frozen ground, rain, traffic, piling and blasting are other factors which increase risk of landslide. The risk also increases on sloping ground. If it is not possible to dig a trench and adequately slope its sides, always install shoring equipment.

Loose ground may easily give way under weight of the machine.

When working on loose or unstable ground, it is important not to dig too deep and to carefully reposition the machine. Do not panic and do not raise bucket, if ground should begin to collapse. Lower work equipment to improve stability of machine.

Never dig under machine, if there is a potential of causing a landslide.

3. Keep the terrain where the machine is working and travelling in good condition:
  - Remove any large rocks or obstacles;
  - Fill any ditches and holes;
  - Provide machines and schedule time to maintain terrain conditions.
4. Use a seat in conformance with ISO 7096 and keep the seat maintained and adjusted:
  - Adjust the seat and suspension for the weight and size of the operator;
  - Inspect and maintain the seat suspension and adjustment mechanisms.
5. Steer, brake, accelerate, shift gears, and move the attachments smoothly.
6. Adjust the machine speed and travel path to minimize the vibration level:
  - Drive around obstacles and rough terrain conditions;
  - Slow down when it is necessary to go over rough terrain.
7. Minimize vibrations for long work cycle or long distance travelling:
  - Use machines equipped with suspension systems;
  - Use lift arm suspensions on wheel loaders;
  - If no suspension system is available, reduce speed to prevent bouncing;
  - Haul machines long distances between worksites.
8. Back pain associated with whole-body vibrations can be caused by other risk factors. To minimize the risk of back pain:
  - Adjust the seat and controls to achieve good posture;
  - Adjust the mirrors to minimize twisted posture;
  - Provide breaks to reduce long periods of sitting;
  - Avoid jumping down from the cab or access system;
  - Minimize repeated handling and lifting of loads;
  - Minimize any shocks and jolts during sports and leisure activities.

## 2. Combination Switch

- A. Left Side Directional Switch - Pushing lever forward, activates left outside directional lights and directional indicator light on instrument panel.
- B. Right Side Directional Switch - Pulling lever back, activates right outside directional lights and directional indicator light on instrument panel.

**NOTE:** When turn is completed, the lever automatically returns to "NEUTRAL" position. Should it not, it can be manually returned by hand.

**NOTE:** Turn signals will function with starter switch in "OFF" position.

- C. Window Washer Switch - When the outside area of the lever is pressed, it activates the washer pump and sprays fluid on the windshield. (Only while being pressed.)

**NOTE:** Do not operate the windshield washer without any fluid. If operated without any fluid, the washer motor may be damaged. Check level in washer tank, and add fluid as required.

**NOTE:** Using soapy water or synthetic detergent instead of window cleaning fluid, can damage the wiper blade or painted surfaces. Use standard window cleaning fluid.

- D. Horn Button - The center button on end of lever activates horn. (Only while being pressed.)
- E. Wiper Switch - Activates wipers when outside area of lever is rotated.

J: Intermittent Mode - wiper every five seconds.

0: Stop (Off).

I: Normal Speed Mode.

II: High-speed Mode.

- F. Neutral Position - Normal low beams.
- G. Pull up to 1st step - Momentarily turns "ON" both the low beams and high beams. (It returns to "NEUTRAL" position when released.)
- H. Pull up to 2nd step - The high beams turn "ON". (It returns to "NEUTRAL" position when released.) For turn off, pull up 2nd step again.

**NOTE:** High and low beams will only function with the headlight switch in the "||" position.

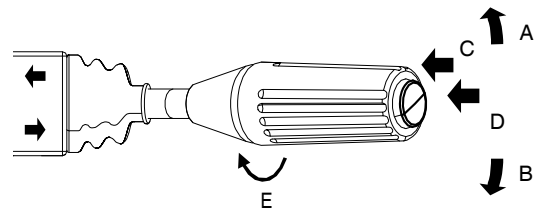

FG018956

Figure 10

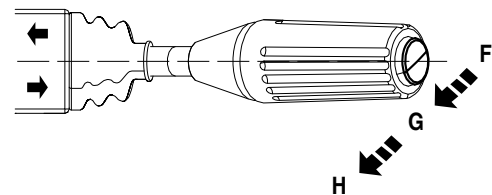

FG018957

Figure 11

---

# IMPORTANT

---

All gauge and warning lights (except for the turn lights, high beam light, work lights and transmission cutoff light) turn "ON" for two seconds with a warning buzzer sound when the starter switch is turned to "I" (ON) position.

If any light fails to turn "ON", check the cause and replace.

---

## Password Activated

If a password has already been set and the system has been "LOCKED", the password display will appear on the screen once the function check has been completed. Enter the password into the text area and then engage the starter.

**NOTE:** Refer to "Set Password (Lock and Unlock)" on page 2-41, for further details.

***If the password does not match the stored password, the engine will not start.***

## 1. Speedometer

This meter displays speed at which the machine is traveling.

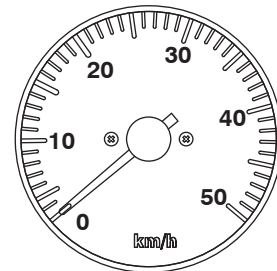

FG004182

Figure 29

## 2. Multifunction Gauge and Graphic Information Display

See "Multifunction Gauge and Graphic Information Display" on page 3-25 This section will have a more in-depth explanation of the display area.

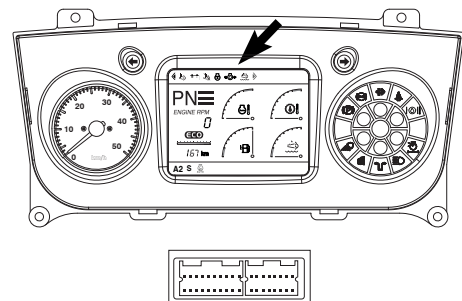

FG019107

Figure 30

C. Initializing trip meter

To reset trip meter to 0 km, press SELECTION (↵) button for three (3) seconds while instrument display is flashing.

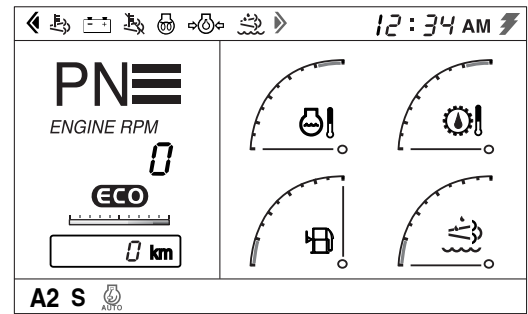

FG019117

Figure 56

D. Switching display to battery voltage

While instrument display is flashing and trip meter is displayed, press UP (▲) button to switch display to battery voltage. Enter change by pressing SELECTION (↵) button, or cancel change by pressing ESC button.

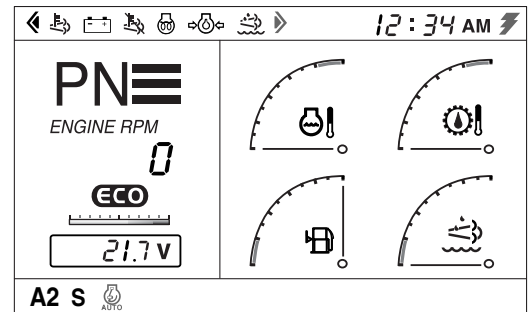

FG019118

Figure 57

E. Switching display to total time of operation

While instrument display is flashing and battery voltage is displayed, press UP (▲) button to switch display to total time of operation. Enter change by pressing SELECTION (↵) button, or cancel change by pressing ESC button.

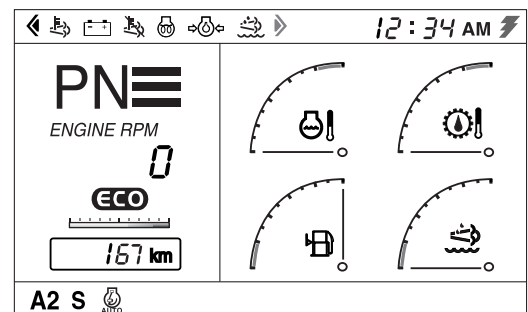

FG019116

Figure 58

### 3. Read Warning Message

Select warning symbol by pressing SELECTION (↵) button to read warning message.

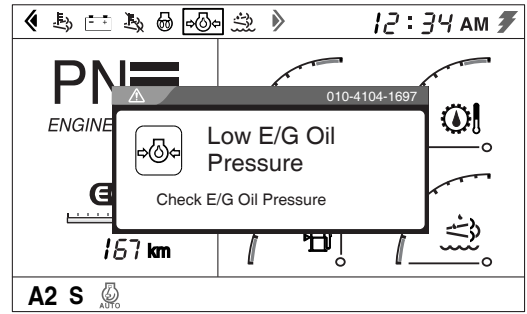

FG019127

Figure 88

### 4. Delete Warning Pop-up

Press ESC button to delete warning pop-up.

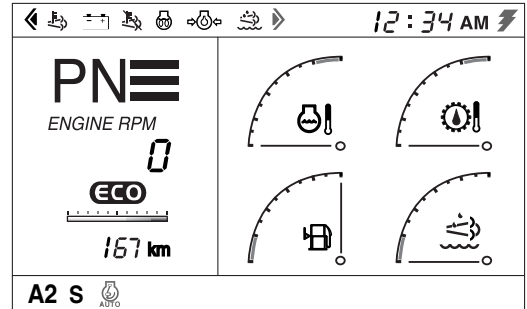

FG019128

Figure 89

**NOTE:** The screen brightness is set as 80% at factory.

Press ESC button to return to previous screen.

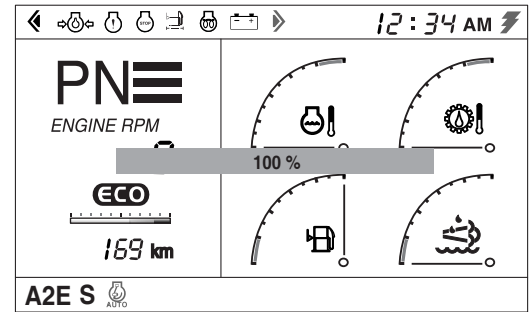

FG019193

Figure 120

C. Default Screen Setting

On "GP Setup" screen, when cursor is placed on "Default Screen Setting", press SELECTION (↵) button switch to access default screen setting.

On default screen setting, press UP (▲) or DOWN (▼) button and locate cursor at a desired style. Then, press SELECTION (↵) button to select style.

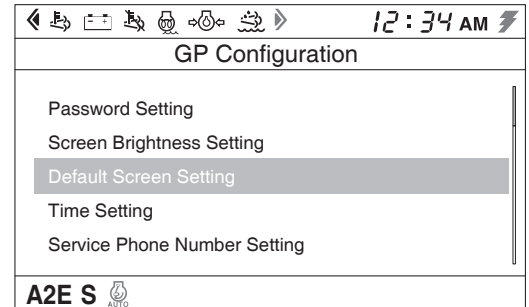

WL1300783

Figure 121

The selected style screen is displayed as normal display screen.

The screen is set as Style #1 at factory.

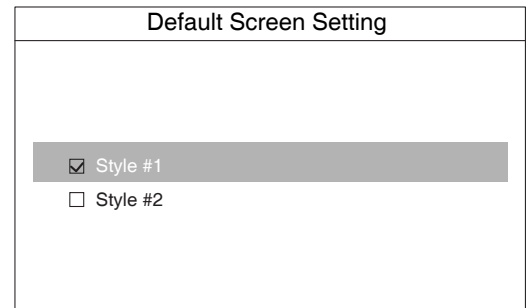

FG019195

Figure 122

## 4. Starter Switch

A three-position starter switch is used to start or stop engine for machine operation.

- O. Turning switch to this position turns engine electrical system "OFF". In this position, engine is "OFF" but interior cabin light and fuel tank transfer pump (if equipped) are functional.
- I. Turning switch to this position turns engine electrical system "ON". When switch is first turned "ON", six indicator/warning symbols across top of display monitor, will turn "ON" for approximately 2 seconds. The battery warning symbol and engine oil pressure warning symbol will remain "ON" after the other four (4) symbols four have turned "OFF".
- ⊖. Moving switch to this position will crank engine. When engine starts, release key and allow it to return to "I" (ON) position. Do not operate starter switch for more than 15 seconds at a time. This will prevent damage to starter.

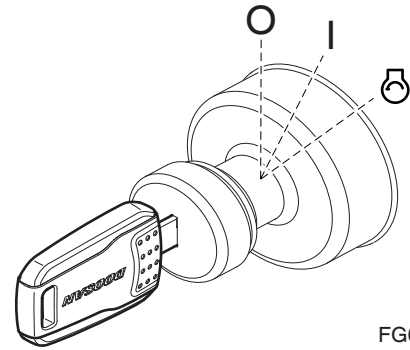

Figure 146

FG018093



### WARNING

**AVOID DEATH OR SERIOUS INJURY**

**DO NOT USE STARTING FLUIDS.** The starting system could cause starting fluid to explode.

## 5. Parking Brake Switch

This switch is used to park the machine.

- O. In this position, parking brake is "RELEASED" and the monitor light on the front display monitor turns "OFF".
- I. In this position, parking brake is "APPLIED" and the monitor light on the front display monitor turns "ON".

**NOTE:** *If parking brake is released, the engine can not be started. To start the engine, engage parking brake first.*

**NOTE:** *When starting the engine parking brake is engaged automatically.*

*To release parking brake, turn parking brake switch "ON" then "OFF" once more although parking brake may look not to be engaged*

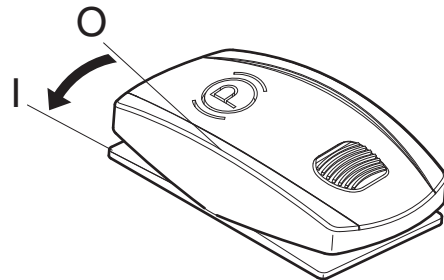



Figure 147

WL1300285

## 4. Quick Coupler Switch (Optional)

This switch is used for securing or releasing the attachment.

- O. In this position , the quick coupler is "LOCKED". The attachment is secured to the quick coupler.
- I. In this position , the quick coupler is "UNLOCKED". The attachment is released from the quick coupler.

**NOTE:** To move the switch, pull up on the toggle and then move it into "UNLOCK" position.

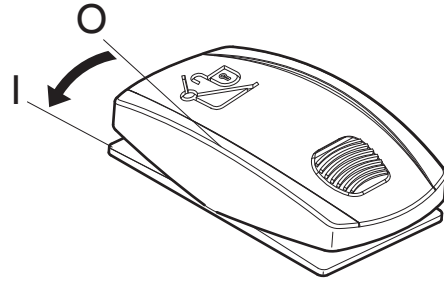

FG023180

Figure 171



## WARNING

**AVOID DEATH OR SERIOUS INJURY**

**DO NOT OPERATE** machine and attachment if quick coupler switch is in "I" () position.

**Attachment can fall off causing death or serious injury.**

## 5. Unified Antenna

This is a Radio and GPS (Optional) antenna.

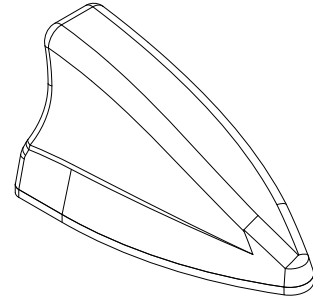

FG019226

Figure 172

## 6. Speakers

Emits sound generated by stereo.

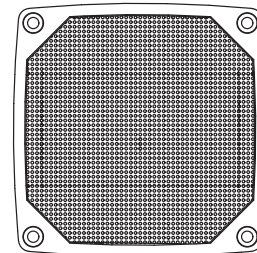

HBOM350L

Figure 173

## 5. Adjustment of Armrest Height

Adjustment height of armrest (6, Figure 199) is done by turning a dial in leftside. When you adjust angle, manually raise armrest before turning dial. Adjustment range is  $\pm 21$  mm.

## 6. Heating Operator's Seat (Optional)

The seat can be heated. The heater switch is located on the right lower front of the seat cushion. To heat the seat press the button up. When heat is not needed press the button down to shut off.

The seat heater has a primary thermostat that allows it to operate up to 50°C (122°F) then shut off and turn back on at 42°C (107.6°F) until the heater switch is turned off.

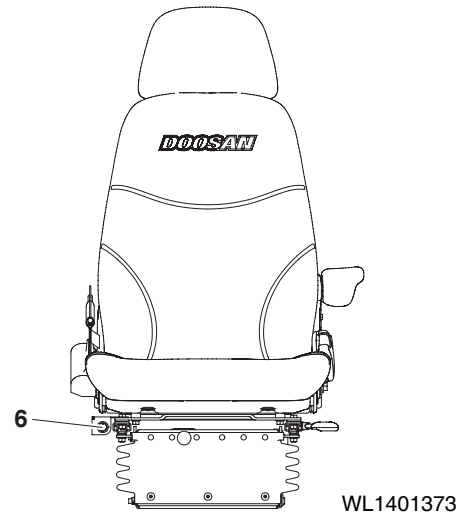

Figure 198

WL1401373

CLICK HERE TO **DOWNLOAD** THE COMPLETE MANUAL

- Thank you very much for reading the preview of the manual.
- You can download the complete manual from: [www.heydownloads.com](http://www.heydownloads.com) by clicking the link below



- Please note: If there is no response to CLICKING the link, please download this PDF first and then click on it.

CLICK HERE TO **DOWNLOAD** THE COMPLETE MANUAL

# Operation

## TO OPERATE A NEW WHEEL LOADER



### WARNING

---

#### AVOID DEATH OR SERIOUS INJURY

Before operating this machine read and understand the operation and maintenance instructions in this manual.

---

### Monitoring System

The monitoring system uses electrical circuits between control system and sensors installed at various machine system locations to monitor selected conditions. The monitoring system's function is to continually inform the operator of the machine's condition. Displays and gauge readouts on the instrument panel provide information such as engine speed, engine coolant temperature, transmission oil pressure, and electrical charge status.

### New Machine Break-in Procedures

All DOOSAN machines are inspected before leaving the factory. However, it is required that operator follow these steps during the initial break-in period. Failure to follow these steps can result in damage to the equipment or reduced performance.

Hour	Load
For first 50 hours of operation	Maintain about 80% load of full capacity (Engine rpm: 80% of rated rpm)
After first 50 hours of operation	Full load

If machine is used at full load before it is broken in, it could affect the overall performance and service life of the machine.

- NOTE:**
1. Check daily for leakage of coolant, fuel, engine oil and hydraulic oil.
  2. Inspect all lubricants daily and add appropriate lubricants as required.

# Cold Weather Starting

## Engine Pre-heater

The engine pre-heater enhances startability by increasing intake air temperature during low-temperature start.

The intake air warmed by the engine pre-heater's operation increases the temperature inside the engine cylinder to facilitate fuel injection and ignition.

### Operating Condition

The preheating function of the engine pre-heater starts at coolant or fuel temperature of 20°C.

### Operation Logic

- To facilitate low-temperature start, turn the starter switch to "ON" to operate the preheating function and initiate the glow plug preheating. The preheating light is displayed on the instrument panel for up to 20 seconds after the key is turned on, and preheating starts automatically. Keeping the key on for a certain period of time based on the temperature is recommended for the glow plug preheating.

Coolant Temperature or Fuel Temperature (Lowest of the Two)	Maintaining Time
0 ~ 20°C (32 ~ 68°F)	Linear Proportionality
below 0°C (32°F)	20 sec

- Preheating is complete when the preheating light turns off. Now, turn the key to engine start for start-up.
- When the engine is started, the fuel supply solenoid valve opens to supply fuel to the glow plug. The fuel supplied to the glow plug is ignited upon injection into the intake manifold to increase the intake air temperature.
- When the engine reaches 500 rpm, or 60 seconds pass after the engine is started, the glow plug and solenoid valve turn off simultaneously.

## IMPORTANT

**Maximum starter engagement time is 30 seconds. Risk of overheating. Allow starter to cool for 2 minutes after each starting attempt before cranking again.**



### CAUTION

**The part poses a fire risk because of use of fuel. Take caution to prevent fuel leakage. Do not turn the key "ON" or start the engine while disassembling each component. If the user arbitrarily attempts to disassemble any component, fuel may leak and cause fire.**

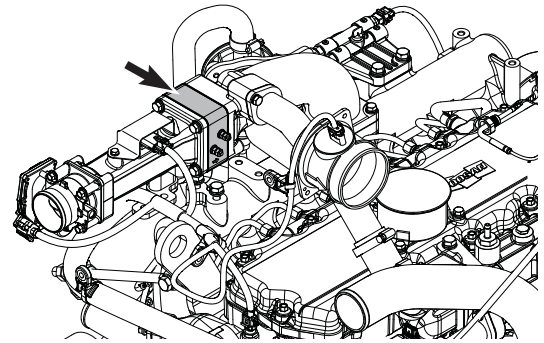

WL1401537

Figure 14

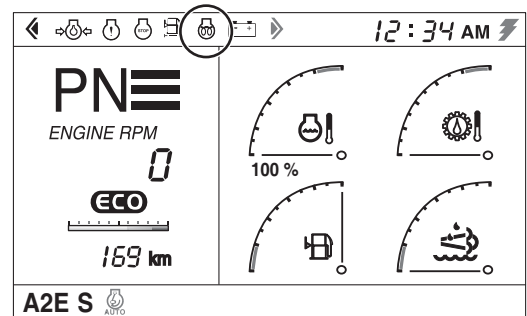

WL1400192

Figure 15

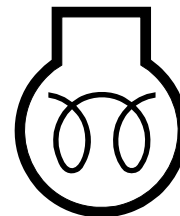

HAAE2000

Figure 16

## Coolant Temperature

Normal coolant temperature during operation is 80°C - 90°C (176°F - 194°F)

Alarm levels are set in the engine control unit. The default setting for the lowest and highest limit values for high temperature are 103°C (217°F) and 105°C (221°F) respectively.

The following function is standard as alarm for high coolant temperature:

- Alarm and torque reduction at the lowest limit value.

The following alarm functions may also be found, depending on how the engine is ordered:

- Alarm only.
- Alarm and engine shutdown at the highest limit value.
- Alarm, torque reduction at the lowest limit value and engine shutdown at the highest limit value.
- Alarm and engine shutdown at the highest limit value with override control.
- Alarm, torque reduction at the lowest limit value and engine shutdown at the highest limit value, with engine shutdown override control.

If operated for extended periods under an extremely light load, the engine may have difficulty in maintaining normal operating temperature. At an increased load, the temperature rises to the normal value.

---

## IMPORTANT

---

**An excessively high coolant temperature can damage the engine.**

---

# F/R (FORWARD/REVERSE) TRAVEL CONTROL SYSTEM

An optional F/R (Forward/Reverse) travel control system can be installed as an option on the machine. With this system installed, the operator's left-hand can remain on the steering wheel during operation, and not have to manually move the transmission lever between forward and reverse.

To activate system, perform the following steps:

1. Place transmission lever in "NEUTRAL".

**NOTE:** *Do not move the transmission lever out of "NEUTRAL". If the lever is moved, the system will be deactivated.*

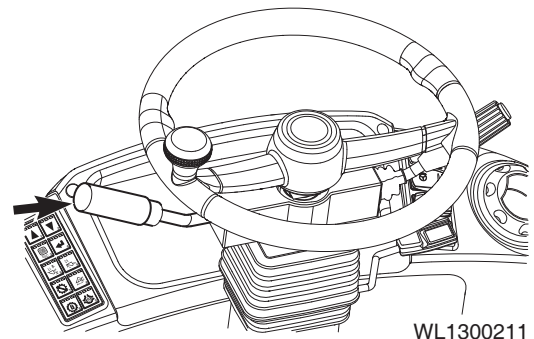

Figure 41

2. Press F/R selector switch to "I" position, and then release. The switch will return to "O" position, but the system will be activated. When system is activated, the F/R selector indicator light (Figure 42) will be turned "ON".

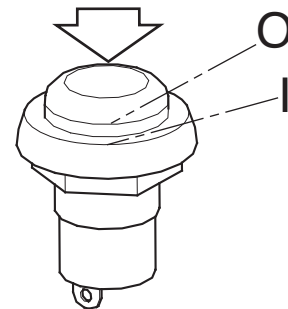

Figure 42

3. The F/R control switch is then used to control the travel direction of the machine.

- O. In this position, the machine is in "NEUTRAL".
- I. In this position, the machine travels "FORWARD".
- II. In this position, the machine travels in "REVERSE".

4. The F/R travel control system will stay activated until one of two things happen.

- A. The transmission lever is moved out of "NEUTRAL" into "FORWARD" or "REVERSE".
- B. The starter switch is turned "OFF".

When the system is deactivated, the F/R selector indicator light will be turned "OFF".

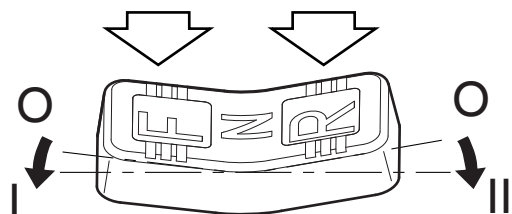

Figure 43

# LONG TERM STORAGE

When a machine is taken out of service and stored for a time exceeding thirty (30) days, steps must be taken to protect the machine. Leaving the machine and work equipment outdoors exposed to the elements will shorten their life.

An enclosure will protect the machine from rapid temperature changes and lessen the amount of condensation that forms in hydraulic components, engine, fuel tank, etc. If it is not possible to put the machine in an enclosure, cover it with a waterproof tarpaulin.

Check that storage site is not subject to flooding or other natural disasters.

After the machine has been positioned for storage and the engine stopped, perform the following operations:

## Before Storage

Keep the machine in the position to prevent rust of the hydraulic piston rods.

- Inspect for damaged, loose or missing parts.
- Repaint areas as necessary to prevent oxidation.
- Wash and clean all parts of machine.
- Replace any damaged or missing decals.
- Store the machine in an indoor, stable place. If stored outside, cover with a waterproof tarp.
- Perform lubrication procedures on all grease points.
- Apply a coating of light oil to the exposed plated metal surfaces (such as hydraulic cylinder rods, etc.) and to all the control linkage and control cylinders. (Control valve spools, etc.)
- Remove battery from the machine to be fully charged and stored.
- Inspect the coolant recovery tank and radiator to make sure the antifreeze level in the system is correct. Make sure that antifreeze concentration is enough for the lowest temperature anticipated during storage.
- Seal all external openings (i.e., engine exhaust outlet, crankcase and hydraulic breather, fuel vent line, etc.) with tape wide enough to cover the opening, regardless of size.

**NOTE:** *When sealing with tape, be sure to extend tape approximately one inch (25 mm) beyond opening to ensure a good seal.*

# HANDLING OIL, FUEL, DEF (ADBLUE) COOLANT

## Oil

- Oil is used in the engine and hydraulic equipment under extremely severe conditions (high temperature, high-pressure, etc.) and deteriorates with use. Always use oil that matches the grade and maximum/minimum ambient temperatures recommended in this manual. Even if oil is not dirty, always change oil at specified interval.
- Always be careful when handling oil to prevent any impurities (water, metal particles, dirt, etc.) from getting into the oil.
- Operating problems with the machine can be caused by impurities in oils.  
Take particular care not to let any impurities get in when storing or adding oil.
- Never mix oils of different grades or brands.
- Always add specified amount of oil.
- Having too much or too little oil can cause operational problems.
- If oil is not clear in color, there may be water or air getting into circuit. In such cases, contact your DOOSAN distributor.
- When changing oil, always replace related filters at same time.

**NOTE:** *Only use Ultra Low Sulfur Diesel (ULSD) fuel and API CJ-4/ACEA E9 grade engine oil.*

## Fuel

To ensure good fuel consumption characteristics and exhaust gas characteristics, the engine mounted on this machine uses an electronically controlled high-pressure fuel injection device. This device uses high precision parts and lubrication. If low viscosity fuel with reduced lubricating ability is used, the durability of the fuel injection device could be adversely affected.

- To prevent moisture in air from condensing and forming water inside fuel tank, always fill fuel tank after completing each day's work.
- The fuel pump will not work properly if fuel containing water or dirt is used.
- Be careful not to let impurities get in when storing or adding fuel.

## **Methods and Precautionary Measures When Removing Paint**

### Blasting

- Use respirator and eye protection.

### Paint remover or other chemicals

- Use a portable air extractor, respirator and protective gloves.

### Grinding machine

- Use a portable air extractor, respirator and protective gloves and eye protection.

## **Rubber That Contains Fluorides**

Take precautions when it is suspected that you may have to handle rubber that contains fluorides.

Certain seals which have to withstand high operating temperatures (e.g. in engines, transmissions, axles, hydraulic motors and pumps) may be made from rubber that contains fluorides, which, when exposed to high heat (fire), forms hydrogen fluoride and hydrofluoric acid. This acid is very corrosive and cannot be rinsed or washed off from the skin. It causes very severe burns which take a long time to heal.

Also, contact with or burns from these chemicals usually cause tissue damage. It usually means that damaged tissue must be surgically removed. Several hours may pass after contact with fluorides, before any symptoms appear and therefore one is not given any immediate warning. The acid may remain on the machine parts for several years after a fire.

If swelling, redness or a stinging feeling appears and one suspects that cause may be contact with heated rubber that contains fluorides, contact a medical doctor immediately. If a machine, or part of a machine, has been exposed to fire or severe heat, it must be handled by specially trained personnel. In all handling of machines after a fire, thick rubber gloves and protective goggles must be used.

The area around a part which has been very hot and which may be made of rubber that contains fluorides must be decontaminated by thorough and ample washing with limewater (a solution or suspension of calcium hydroxide, i.e. slaked lime in water). After the work has been completed, the gloves must be washed in limewater and then discarded.

# LUBRICATION AND SERVICE CHART

## Greasing Bearings

The service life of bushings and pivot pins can be extended considerably if the machine is greased regularly and in the correct way.

**The greasing of bearings has two main purposes:**

- Add grease to the bearing to reduce friction between pin and bushing.
- Replace old grease which may contain dirt. The grease in the space inside the outer seal collects dirt and prevents dirt and water from penetrating into the bearing.

Grease the bearing until new, clean grease is forced out through the outer seal.

Between 10 and 15 strokes with a normal handheld grease gun is required to grease one of the bearings for the lifting arms.

Wipe off grease fittings and grease gun before greasing, so dirt and sand is not introduced through the grease fittings.

2. Check O-ring for damage and replace if necessary. Check position of O-ring at surface of hole.
3. Place the cover on the access hole. Make sure the spring retaining cup (1, Figure 30) in the lower section of the cover is lined up with the spring. The filter assembly rod must be in a vertical position and perpendicular to the base of the tank. The cover can be rotated to align the rod into a vertical position.
4. Tighten mounting bolts to 4.84 kg.m (35 ft lb).

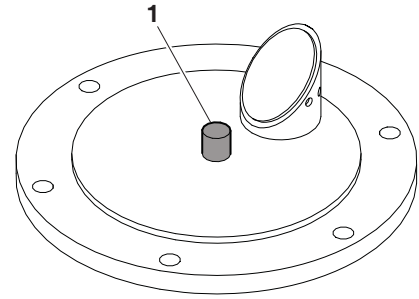

WL1401455

Figure 30

## Check for Leaks in Hydraulic System

1. Perform a daily walk-around inspection to make sure that hoses, piping, fittings, cylinders and hydraulic motors are not showing any signs of leakage. If any is noted, determine the source of the leak and repair.

## Fill Fuel Tank



### WARNING

**AVOID DEATH OR SERIOUS INJURY**

Use proper safety while refueling to prevent explosions or fire.

Immediately clean up any spilled fuel.

1. At the end of each workday, fill fuel tank. Add fuel through fuel fill cap (Figure 31).

**NOTE:** Only use Ultra Low Sulfur Diesel (ULSD) fuel and API CJ-4/ACEA E9 grade engine oil.

**NOTE:** See "Fluid Capacities" on page 4-28 for capacity.

2. Securely tighten cap after fueling.

**NOTE:** If breather holes in cap are clogged, a vacuum may form in the tank preventing proper fuel flow to engine. Keep holes in fuel cap clean.

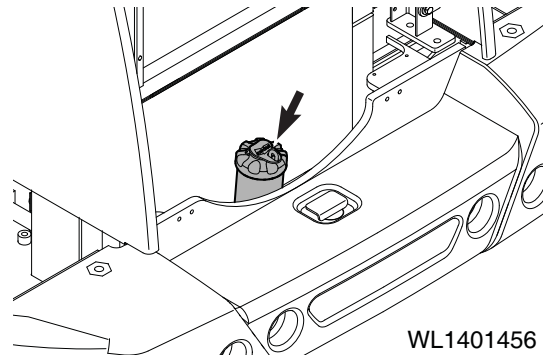

WL1401456

Figure 31

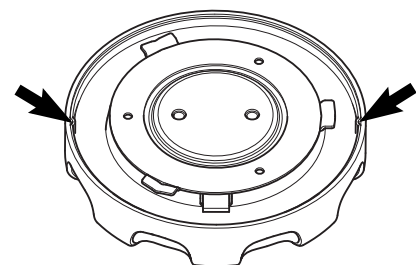

FG001690

Figure 32

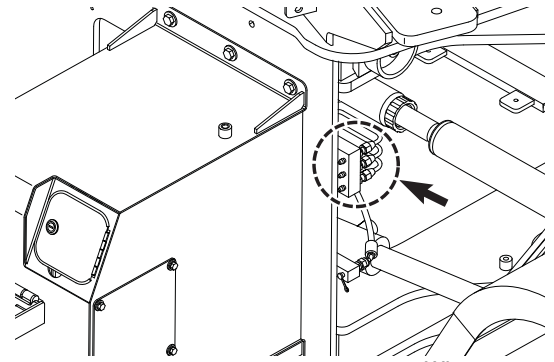
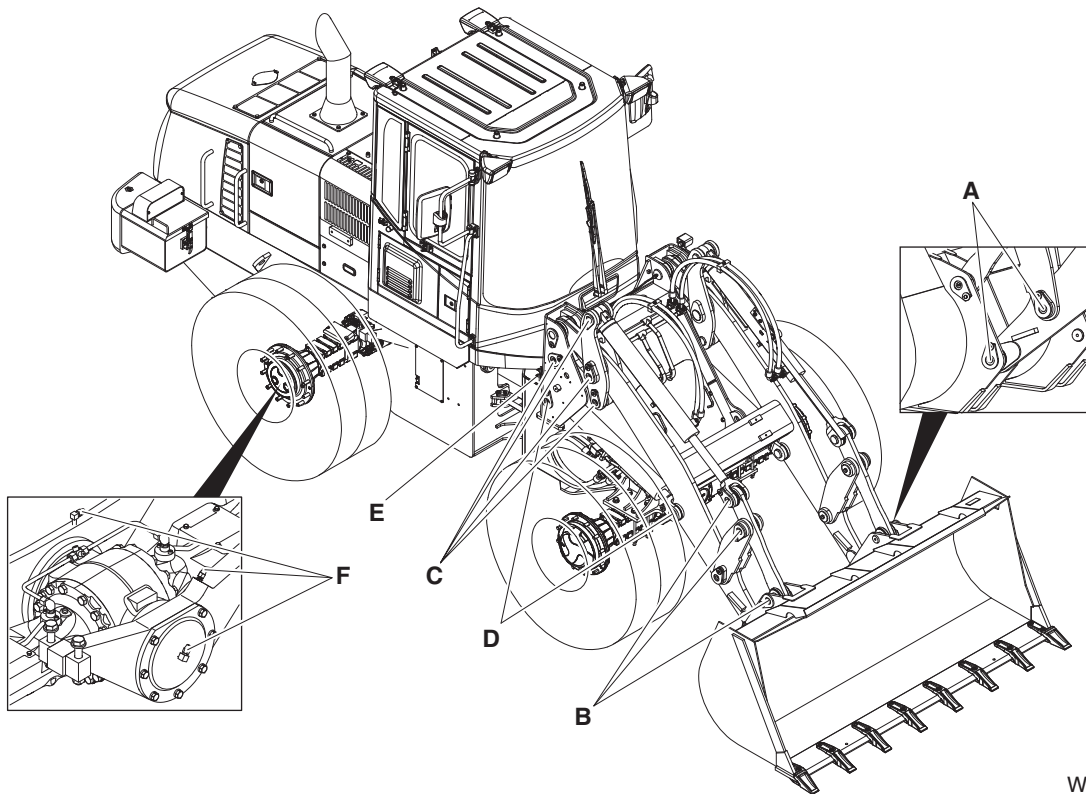

Figure 55

WL1401458

### DL250TC-5

1. The following fittings must be greased daily, or every 10 hours, for first 100 hours of operation to comply with new machine break-in requirements. After that, greasing must be done every 50 hours. If bucket is being used in water, grease fittings immediately after machine is removed from water.



WL1401459

Figure 56

## Check Engine Air Intake Precleaner (Optional)

1. The engine is equipped with a precleaner. Dust, insects, rainwater etc., can be present in the air. The precleaner collects this material and discharges it. This prevents material from being drawn into air cleaner. The precleaner does not need periodic cleaning or replacement.

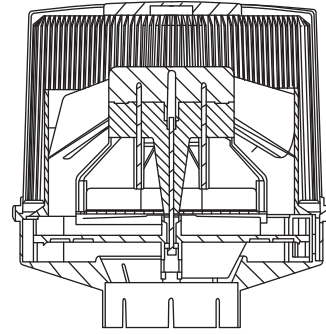

Figure 81

FG014041

## Drain Water From Hydraulic Oil Tank



### WARNING

#### AVOID DEATH OR SERIOUS INJURY

To prevent burn injuries from hot oil splashing, allow hydraulic oil to cool before draining water and sediment.

The hydraulic tank is pressurized. Unscrew the cap of breather on the top of hydraulic tank to allow pressurized air to vent. After pressure has been released, remove either the fill cap or service covers.

1. Position machine on firm and level ground.
2. "ENGAGE" parking brake.
3. Lower bucket or work tool to ground.
4. Move transmission lever to "NEUTRAL" position.
5. Make sure transmission neutral lock is in the "N" (NEUTRAL LOCK) position.
6. Stop engine.
7. Block tires.
8. Position a container under hydraulic tank drain plug. Open hydraulic oil tank cover. (See Figure 28 on page 4-38). Loosen drain valve from bottom of tank (Figure 82). Allow all water and sediment to drain out. Tighten drain valve.

**NOTE:** *Dispose of drained fluids according to applicable environmental laws and regulations.*

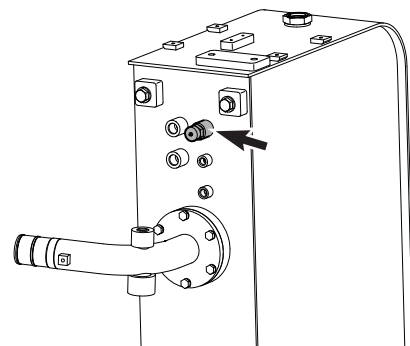

Figure 82

WL1401466

## Change Main Fuel Filter



### WARNING

#### AVOID DEATH OR SERIOUS INJURY

Change filter after waiting for engine to cool. Be careful of fire hazards. Do not smoke.

1. Locate fuel filter inside engine compartment.
2. Position a small container under fuel filter.
3. Unscrew fuel filter from head assembly. Discard fuel filter.

**NOTE:** *Dispose of drained fluids in compliance with all applicable environmental regulations.*

4. After cleaning filter head, install new fuel filter. Screw filter on head until gasket contacts head, and turn filter 1/2 turn more with a filter wrench.

**NOTE:** *Coat fuel filter gasket with fuel.*

**NOTE:** *Fill fuel filter with clean fuel. This will help reduce fuel system priming.*

**NOTE:** *Only use Ultra Low Sulfur Diesel (ULSD) fuel and API CJ-4/ACEA E9 grade engine oil.*

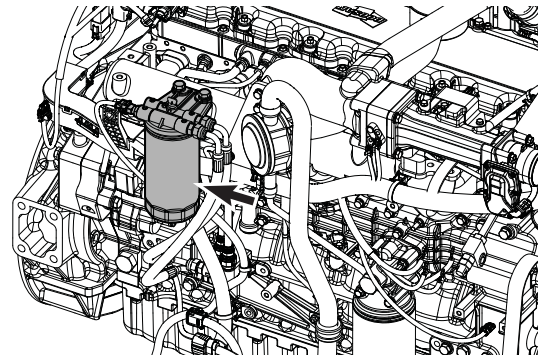

Figure 100

WL1401472

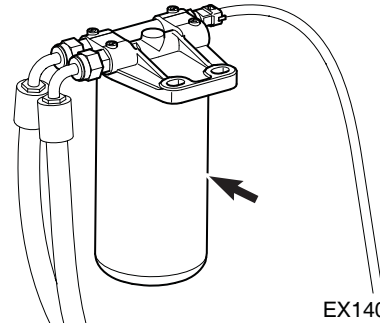

Figure 101

EX1401860

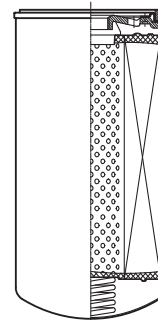

Figure 102

FG000478

# 1,500 HOUR / 9 MONTH SERVICE

## Perform All Daily, 50, 250 and 500 Hour Service Checks

### Change Axle Differential and Planetaries Oil

**NOTE:** *Oil in both front and rear axles must be replaced after first 500 hours of operation to comply with new machine break-in requirements. After that, axle oil check must be done every 500 hours of operation and replacement must be done every 1,500 hours.*

Each axle contains a center differential, and a planetary on each end. The same oil lubricates the center differential and planetaries. These sections of the axle are connected, but the oil flows very slowly between them. When checked, oil must be checked and refilled at the level/fill plug on the differential housing.

To drain and replace oil in an axle, perform the following steps:

1. Position machine on firm and level ground.
2. "ENGAGE" parking brake.
3. Lower bucket or work tool to ground.
4. Move transmission lever to "NEUTRAL" position.
5. Make sure transmission neutral lock is in the "N" (NEUTRAL LOCK) position.
6. Stop engine.
7. Block tires.
8. Clean areas around drain plugs on both ends of axle. Remove plugs and allow oil to drain into a suitable container.

**NOTE:** *See "Fluid Capacities" on page 4-28 for capacity.*

**NOTE:** *Dispose of drained fluids according to applicable environmental laws and regulations.*

**NOTE:** *Plug Size: M24 x 1.5  
Tightening Torque: 7.1 kg.m (51 ft lb)*

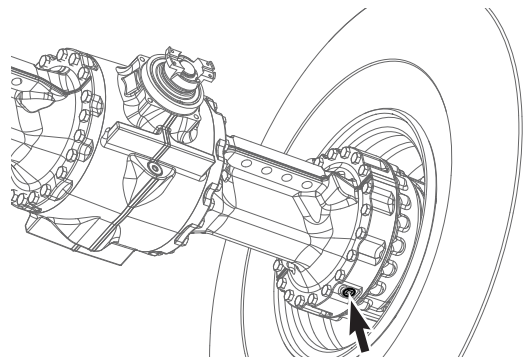

**Figure 117**

WL1401479

8. Apply oil to the O-ring and install a new filter.

---

 **CAUTION**

**AVOID INJURY**

**Use Mobil Velocite No. 6 oil from Bosch.**

---



EX1401882

Figure 138

9. Install a new equalizing element.



EX1401883

Figure 139

10. Tighten the filter cover to 20 N.m + 5 N.m.

---

 **CAUTION**

**AVOID INJURY**

**Check that filter surface is clean. It can be cleaned with water only.**

---



EX1401884

Figure 140

## Pilot Supply Pressure

1. Attach gauge to port.
2. Adjust relief cartridge (Figure 148) on brake and pilot and fan motor supply valve. Pressure must be set at:  $30 \pm 2$  bar ( $30 \pm 2$  kg/cm<sup>2</sup> (435  $\pm$  29 psi)).
3. Loosen locknut on adjusting screw. Turn adjusting screw clockwise to raise relief pressure. Turn adjusting screw counterclockwise to lower relief pressure.
4. Tighten locknut after adjustment.
5. If the pressure doesn't change, the maximum current value of pump control must be changed by DMS.

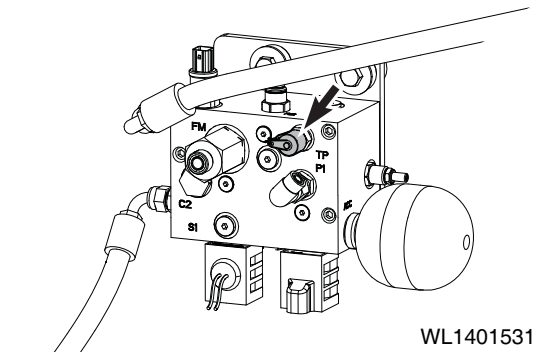

Figure 148

WL1401531

## Main Pump Pressure

1. Attach gauge to port.
  2. Pressure cutoff setting for main pump:  
 $265 \pm 5$  bar ( $270 \pm 5$  kg/cm<sup>2</sup> (3,843  $\pm$  73 psi)).
- NOTE:** When you check main pump pressure, front should be operating.

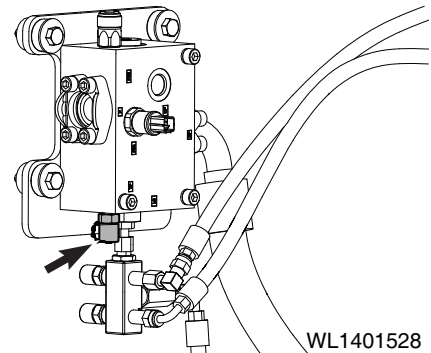

Figure 149

WL1401528

## Brake Charging Pressure

1. Attach gauge to port.
2. Adjust relief valve cartridge on brake, pilot and fan motor supply valve (Figure 150). The minimum set pressure (Figure 150) for brake charging is:  
 $100 \sim 160$  bar ( $102 \sim 163$  kg/cm<sup>2</sup> (1,450  $\sim$  2,321 psi))

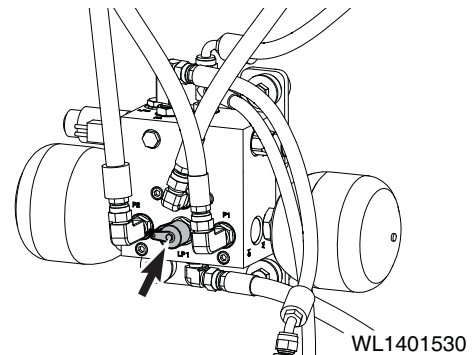

Figure 150

WL1401530

## Recommended Air Pressure

Tire	Working Pressure		Driving Pressure		Remarks
	Front Tire	Rear Tire	Front Tire	Rear Tire	
Bias Ply Tire	4.1 <sup>+0.1</sup> <sub>+0</sub> kg/cm <sup>2</sup> (4.1 <sup>+0.1</sup> <sub>+0</sub> bar (60 <sup>+2</sup> <sub>+0</sub> psi))	3.5 <sup>+0.1</sup> <sub>+0</sub> kg/cm <sup>2</sup> (3.5 <sup>+0.1</sup> <sub>+0</sub> bar (50 <sup>+2</sup> <sub>+0</sub> psi))	4.1 <sup>+0.1</sup> <sub>+0</sub> kg/cm <sup>2</sup> (4.1 <sup>+0.1</sup> <sub>+0</sub> bar (60 <sup>+2</sup> <sub>+0</sub> psi))	3.5 <sup>+0.1</sup> <sub>+0</sub> kg/cm <sup>2</sup> (3.5 <sup>+0.1</sup> <sub>+0</sub> bar (50 <sup>+2</sup> <sub>+0</sub> psi))	
Radial Ply Tire	4.3 <sup>+0.1</sup> <sub>+0</sub> kg/cm <sup>2</sup> (4.3 <sup>+0.1</sup> <sub>+0</sub> bar (62 <sup>+2</sup> <sub>+0</sub> psi))	3.1 <sup>+0.1</sup> <sub>+0</sub> kg/cm <sup>2</sup> (3.1 <sup>+0.1</sup> <sub>+0</sub> bar (44 <sup>+2</sup> <sub>+0</sub> psi))	4.3 <sup>+0.1</sup> <sub>+0</sub> kg/cm <sup>2</sup> (4.2 <sup>+0.1</sup> <sub>+0</sub> bar (62 <sup>+2</sup> <sub>+0</sub> psi))	3.1 <sup>+0.1</sup> <sub>+0</sub> kg/cm <sup>2</sup> (3.1 <sup>+0.1</sup> <sub>+0</sub> bar (44 <sup>+2</sup> <sub>+0</sub> psi))	

The recommended tire pressures are based on the rated load for each handling case.

In case of heavier loads, especially during loading and carrying operations, a higher tire pressure is required. Contact the tire manufacturer for information about which air pressure is the correct one for the load to be handled and transported over a particular distance.

If L5 tires are used for loading and carrying operations, special attention must be paid to the transporting distances.

Radial tires are preferred for loading and carrying operations, as the build-up of heat is less with this type of tire.

<b>Problem</b>	<b>Cause</b>	<b>Remedy</b>
Engine knocks, runs unevenly or surges.	Low engine oil.	Add oil.
	Plugged air intake system.	Clean system and replace filter.
	Plugged fuel filter.	Replace fuel filter.
	Water or dirt in fuel system.	Clean system and add new fuel.
	Clogged or dirty fuel injectors.	Contact your DOOSAN distributor.
Engine has poor power.	Plugged air intake system.	Clean system and replace filter.
	Clogged or dirty fuel injectors.	Contact your DOOSAN distributor.
	Fuel filters plugged.	Replace filters.
	Valve backlash faulty.	Adjust backlash.
	Exhaust system after-treatment parts faulty.	Check connectors and clean DEF (AdBlue) filter or replace filter.
	Low DEF (AdBlue) level.	Add DEF (AdBlue).
Engine runs hot.	Low coolant level.	Add coolant.
	Thermostat faulty.	Replace thermostat.
	Radiator cap faulty.	Replace radiator cap.
	Radiator core plugged.	Clean radiator.
	Oil cooler core plugged.	Clean oil cooler.
	Fan belt loose or damaged.	Tighten or replace as required.
	Temperature sensor faulty.	Replace sensor.
Engine oil pressure warning light turns "ON", and buzzer sounds.	Low engine oil level.	Add oil.
	Wrong grade oil for weather.	Change oil.
	Clogged oil filter.	Change filter and oil.
	Defective alarm switch.	Contact your DOOSAN distributor.
	Oil leakage from pipe or joint.	
	Clogged suction strainer.	
	Excessive engine wear.	
	Defective oil pump.	

DL250TC-5		
Item	Specification	
Standard Bucket Capacity (BOT / BOC)	2.4 m <sup>3</sup> (3.1 yd <sup>3</sup> ) / 2.5 m <sup>3</sup> (3.3 yd <sup>3</sup> )	
Vehicle Weight	14,215 kg (31,340 lb)	
Engine		
Emission	US EPA Tier 4 (EU Stage IV)	
Maker and Model	Doosan Infracore / DL06P	
Type	4-Cycle Water Cooled, Turbocharge, Direct Injection, Exhaust Gas Recirculation	
Rated Gross Power	128 kW (172 HP) @ 2,100 rpm (SAE J1995)	
Transmission		
Full Automatic Power -Shift	Full Automatic Power Shift	
Speeds	4 Forward, 3 Reverse	
Brake Systems		
Travel Brakes	4 Wheel, Wet Disk	
Parking Brake	SAHR, Dry Disk Type	
Performance		
Travel Speed km/h (MPH)	4 speed (Forward)	6.6 (4.0) / 11.9 (7.4) / 23.0 (14.3) / 37.8 (23.5)
	3 speed (Reverse)	6.9 (4.3) / 12.5 (7.8) / 24.2 (15.0)
Steering Angle	±40°	
Minimum Tire Turning Radius (Out Tire Edge)	5,475 mm (18')	
Rated Operating Load	4,225 kg (9,315 lb)	
Maximum Breakout Force (Bucket)	102 kN (22,931 lb)	
Arm Raise Time	5.9 ±0.5 Sec.	
Bucket Dump Time	3.3 ±0.3 Sec.	
Arm Lowering Time	3.4 ±0.4 Sec.	
Maximum Gradeability	30° (58%)	

CLICK HERE TO **DOWNLOAD** THE COMPLETE MANUAL

- Thank you very much for reading the preview of the manual.
- You can download the complete manual from: [www.heydownloads.com](http://www.heydownloads.com) by clicking the link below



- Please note: If there is no response to CLICKING the link, please download this PDF first and then click on it.

CLICK HERE TO **DOWNLOAD** THE COMPLETE MANUAL