

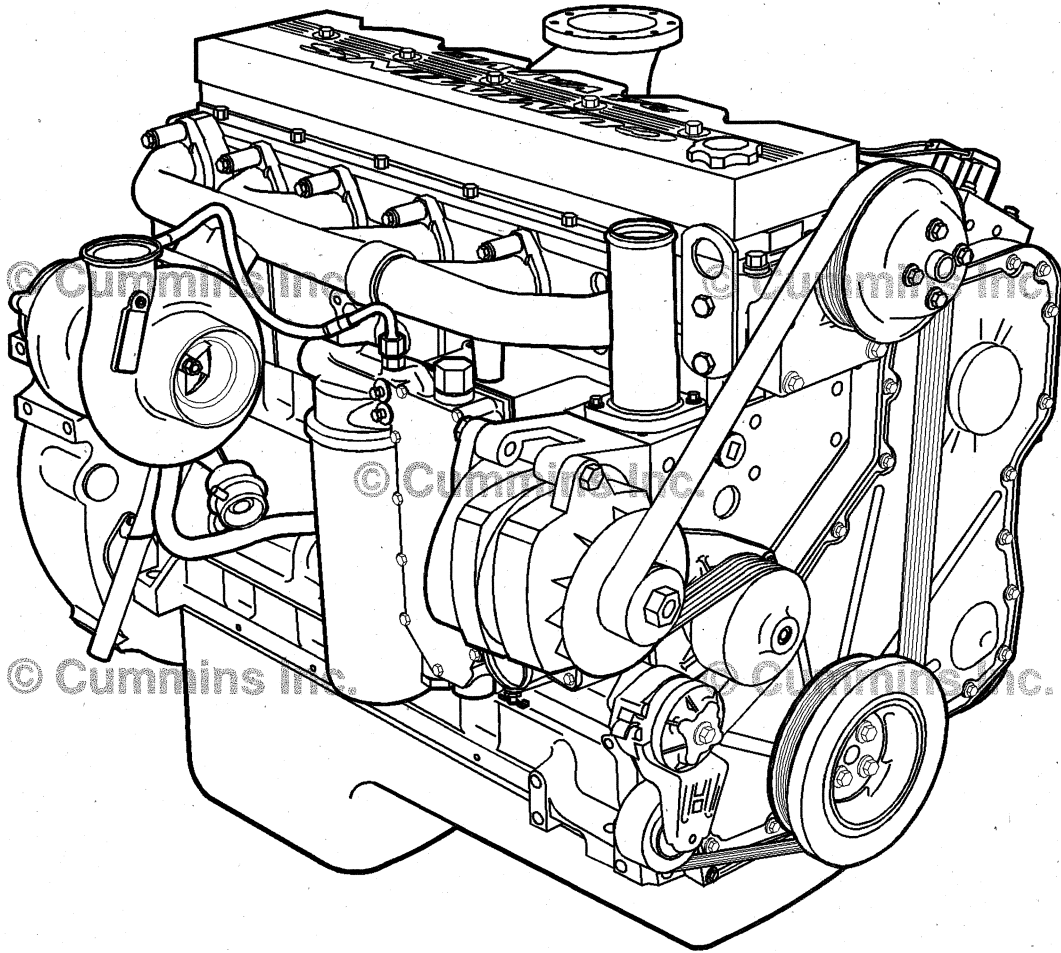

Operation and Maintenance Manual QSC8.3 and QSL9 Engine



00d00016

CLICK HERE TO **DOWNLOAD** THE COMPLETE MANUAL

- Thank you very much for reading the preview of the manual.
- You can download the complete manual from: www.heydownloads.com by clicking the link below



- Please note: If there is no response to CLICKING the link, please download this PDF first and then click on it.

CLICK HERE TO **DOWNLOAD** THE COMPLETE MANUAL

Section E - Engine Identification

Section Contents

	Page
Engine Diagrams	E-3
Engine Views.....	E-3
Engine Identification	E-1
Cummins® Engine Nomenclature.....	E-2
ECM Dataplate.....	E-2
Engine Dataplate.....	E-1
Fuel Injection Pump Dataplate.....	E-2

Section FB - Industrial Features

Section Contents

	Page
Accelerator Options	FB-10
Disadvantages.....	FB-10
Driver Activation/Deactivation.....	FB-10
Feature Description.....	FB-10
Interaction with other Features and Parameters.....	FB-10
Visual Aids.....	FB-10
Automatic Boost Power	FB-1
Disadvantages.....	FB-1
Driver Activation/Deactivation.....	FB-1
Feature Description.....	FB-1
Interaction with other Features and Parameters.....	FB-1
Visual Aids.....	FB-1
Cruise Control	FB-2
Disadvantages.....	FB-3
Driver Activation/Deactivation.....	FB-3
Feature Description.....	FB-2
Interaction with other Features and Parameters.....	FB-3
Visual Aids.....	FB-4
Engine Protection	FB-4
Disadvantages.....	FB-4
Driver Activation/Deactivation.....	FB-4
Feature Description.....	FB-4
Interaction with other Features and Parameters.....	FB-4
Visual Aids.....	FB-5
Fan Control	FB-5
Disadvantages.....	FB-5
Driver Activation/Deactivation.....	FB-5
Feature Description.....	FB-5
Interaction with other Features and Parameters.....	FB-5
Visual Aids.....	FB-5
Hot Shutdown Monitor	FB-5
Disadvantages.....	FB-6
Driver Activation/Deactivation.....	FB-6
Feature Description.....	FB-5
Interaction with other Features and Parameters.....	FB-6
Visual Aids.....	FB-6
Alternate Droop	FB-9
Disadvantages.....	FB-9
Driver Activation/Deactivation.....	FB-9
Feature Description.....	FB-9
Interaction with other Features and Parameters.....	FB-9
Visual Aids.....	FB-10
Integrated Idle Management	FB-10
Disadvantages.....	FB-11
Driver Activation/Deactivation.....	FB-10
Feature Description.....	FB-10
Interaction with other Features and Parameters.....	FB-11
Visual Aids.....	FB-11
Intermediate Speed Control (ISC)	FB-6
Disadvantages.....	FB-7
Driver Activation/Deactivation.....	FB-6
Feature Description.....	FB-6
Interaction with other Features and Parameters.....	FB-7
Visual Aids.....	FB-7
Maintenance Monitor	FB-7
Disadvantages.....	FB-8
Driver Activation/Deactivation.....	FB-7

Visual Aids

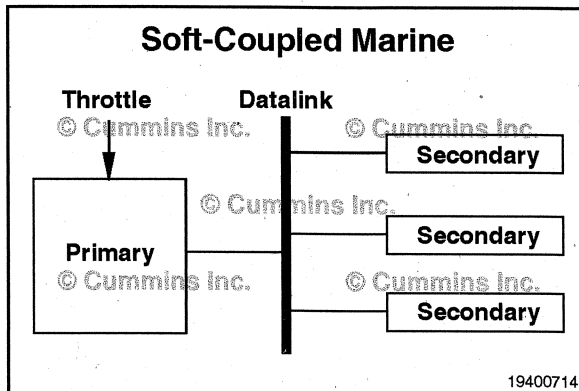
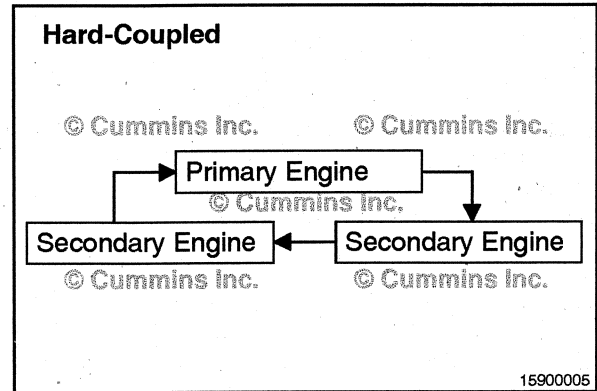
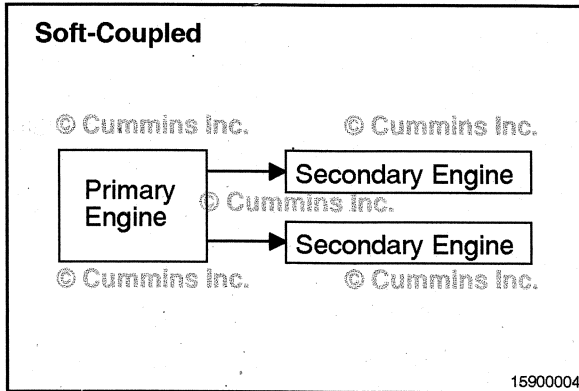

Alternate Droop

Feature Description

Alternate Droop allows the droop characteristics to be changed for the automotive (minimum or maximum) and for Variable Speed (VS) governor or All Speed Governor. In general less governor droop (lower percentage) provides a more responsive governor for more precise engine control. More governor droop (higher percentage) provides smoother shifting and smoother mechanical clutch engagement. This feature, depending on Original Equipment Manufacturer (OEM) availability, provides the user the ability to select multiple breakpoint speeds and the droops associated with those speeds by way of an OEM-provided switch.

Driver Activation/Deactivation

Alternate Droop is calibration activated (except for SELECT™ Plus), but uses a switch to toggle between the alternate droop settings. Depending on the application the alternate droop switch can be a 2 or 3 position switch. Toggling the switch into the 2nd and 3rd positions will activate the 2nd and 3rd droop settings accordingly.

Interaction with other Features and Parameters

The Vehicle Speed Droop feature uses the droop settings for this feature.

Disadvantages

- Driver complains of low power.
- Driver complains of poor or unexpected throttle reaction.

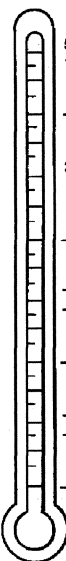
Cold Weather Operating Aids										
Temperature	Starting Aid	Coolant Heater	Oil Heater	Under-hood Air	Fuel Heater	Battery Heater	Radiator Shutters	Engine Enclosure	Winter Front	Thermatic Fan
 50 to 32° F 10 to 0° C © Cummins Inc.										© Cummins Inc.
32 to -10° F 0 to -23° C	↑	↑	↑	↑	↑	↑	↑	↑		Suggested
-10 to -25° F -23 to -32° C	↑ Required	↑ Required	↑ Required	↑ Required	↑ Required	↑ Required	↑ Required	↑ Required	↑ Required	↑ Required
-25 to -65° F -32 to -54° C	↓	↓	↓	↓	↓	↓	↓	↓	↓	↓

* Required dependent upon viscosity/pour point.

oi202vj

Winterfronts and Shutters

Winterfronts and shutters can be used on a vehicle or equipment to reduce air flow through the radiator core into the engine compartment. This can reduce the time required to warm the engine and help maintain the engine coolant temperature. The engine coolant temperature specifications are in the Maintenance Specification (Section V).

Depending on original equipment manufacturer (OEM) availability the alternate droop feature provides the ability to select up to two additional alternate droop settings by an original equipment manufacturer (OEM) provided switch.

The type of droop switch (position 1, position 2, and position 3) can be adjusted using the INSITE™ service tool.

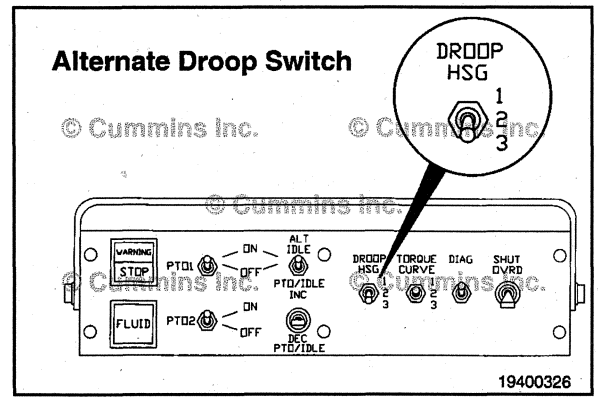

Each alternate droop setting provides the ability to select the high speed governor break point speed and droop percent. Droop percent at minimum and maximum throttle for the vehicle speed (VS) governor is also adjustable. The break point speed determines the position on the engine torque curve where high speed governor will start to limit engine torque output. Selection of the alternate droop feature is accomplished by using the INSITE™ electronic service tool if the alternate droop feature is available in the calibration.

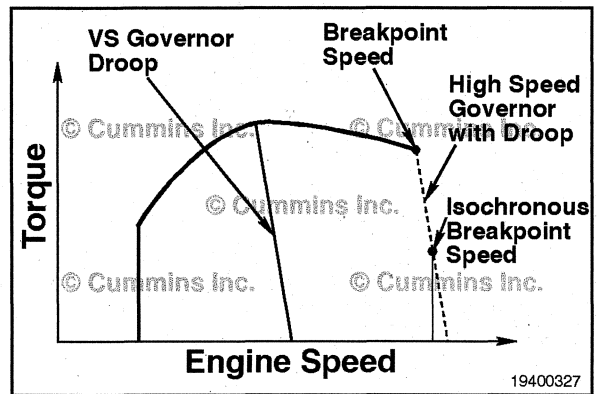

Switched Torque

The switched torque feature allows the operator to switch between the 100-percent throttle torque curve (1) and up to two derated torque curves (2 and 3). (The axis 4 is engine speed and 5 is engine torque.)

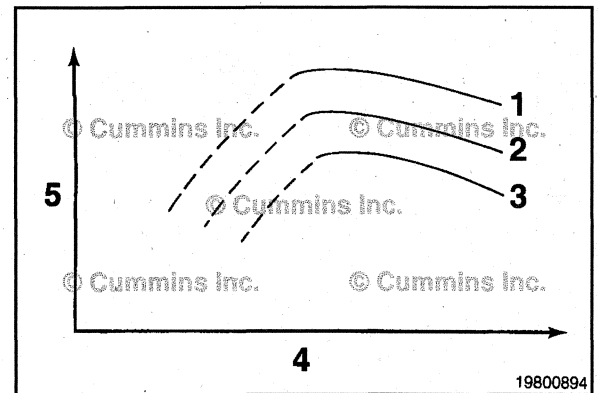

This feature improves operating efficiency in loaded (1) versus unloaded (2), as well as protecting the transmission and drivetrain.

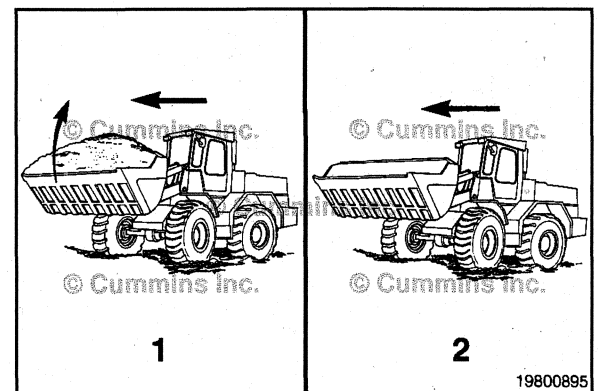

Maintenance Monitor

⚠CAUTION⚠

The maintenance monitor is designed to alert the operator of the need for a routine maintenance stop. Maintenance records must still be maintained for historical purposes.

⚠CAUTION⚠

The maintenance monitor uses data received from the electronic control module (ECM) to determine the amount of fuel burned. Whenever a battery voltage fault has occurred, the maintenance monitor data can be inaccurate.

The maintenance monitor is an optional feature that will alert the operator when it is time to change oil and perform any other simultaneous maintenance tasks. The maintenance monitor continuously monitors the time the engine has been operating and the amount of fuel burned, to determine when it is time to change oil.

NOTE: The operator **must** still be alert for any indications that the engine needs other service.

The maintenance monitor has three modes of operation:

- Automatic mode
- Manual mode
- Time mode.

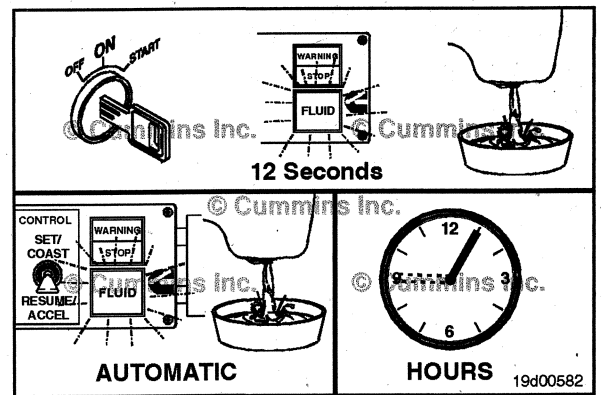
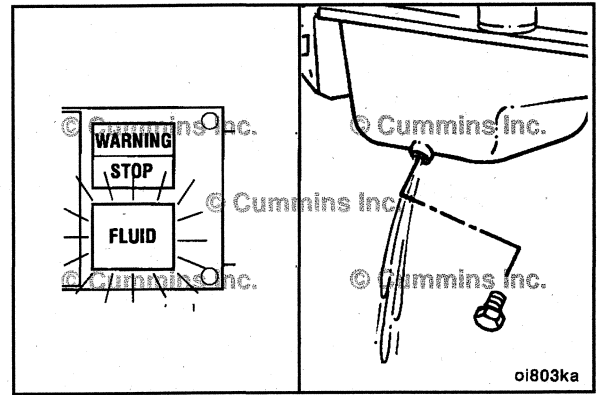

Maintenance Monitor Automatic Mode

⚠CAUTION⚠

The use of synthetic-base oil does not justify extended oil change intervals. Extended oil change intervals will decrease engine life because of factors such as corrosion, deposits, and wear.

The automatic mode alerts the operator when it is time to change oil based on Cummins recommended interval. It determines the maintenance interval based on coolant temperature and load factor.

When the automatic mode is selected, the severe oil drain interval duty cycle is the default.

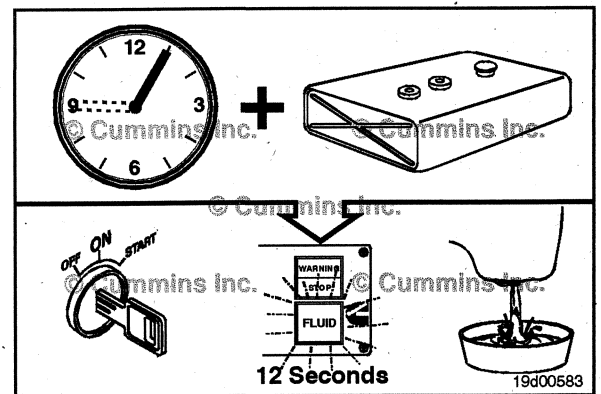

Maintenance Guidelines - Overview

General Information

Cummins Inc. recommends that the engine be maintained according to the Maintenance Schedule in this section.

If the engine is operating in ambient temperatures below -18°C [0°F] or above 38°C [100°F], perform maintenance at shorter intervals. Shorter maintenance intervals are also required if the engine is operated in a dusty environment or if frequent stops are made. Contact your local Cummins Authorized Repair Location for recommended maintenance intervals.

Some of these maintenance procedures require special tools or must be completed by qualified personnel. Contact your local Cummins Authorized Repair Location for detailed information.

If your engine is equipped with a component or accessory not manufactured by Cummins Inc., refer to the component manufacturer's maintenance recommendations.

Use the chart provided in this section as a convenient way to record maintenance performed.

Replace original equipment fan that is damaged with a fan of the identical part number. Cummins Inc. **must** approve any other fan changes to be covered under warranty.

Refer to the vehicle or equipment manufacturer's specifications for capscrew torque.

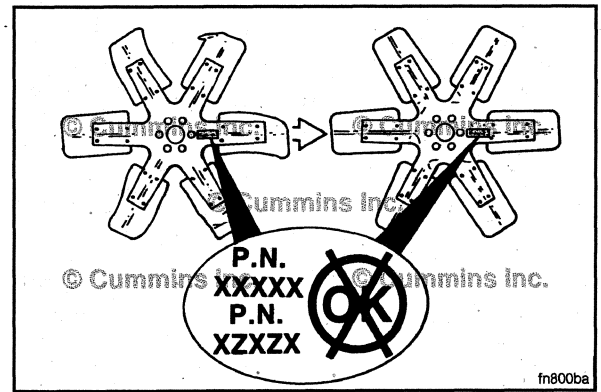

Crankcase Breather Tube Maintenance Check

Inspect the breather tube for sludge, debris, or ice in the tube.

Inspect the tube more frequently in icy conditions.

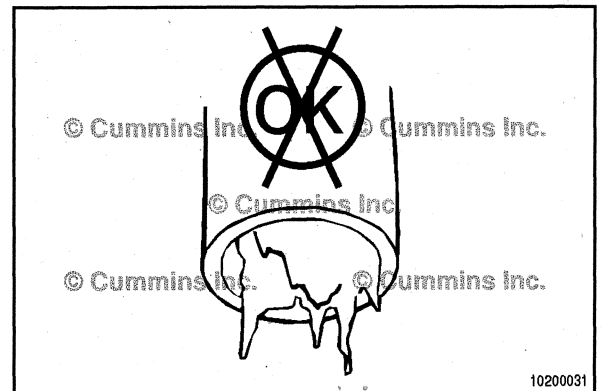

Air Tanks and Reservoirs Drain

If automatic purging or spitter valves are used, confirm the valves are operating correctly. If a manual drain valve is used on the wet tank, open the draincock on the wet tank to drain any moisture accumulated in the air system. If oil is present, the air compressor system **must** be checked. Contact your Cummins Authorized Repair Location.

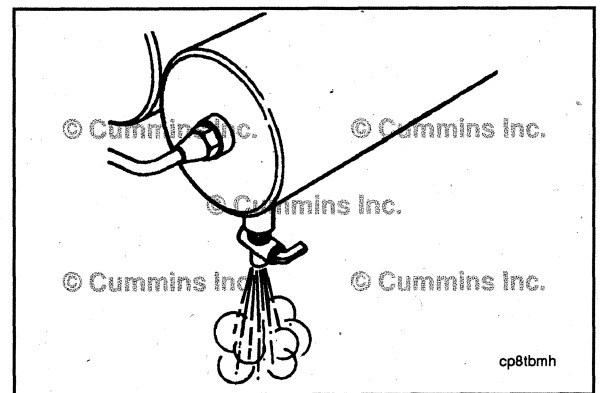

Coolant Level Maintenance Check



Do not remove a pressure cap from a hot engine. Wait until the coolant temperature is below 50°C [120°F] before removing the pressure cap. Heated coolant spray or steam can cause personal injury.



Never use a sealing additive to stop leaks in the cooling system. This can result in cooling system plugging and inadequate coolant flow, causing the engine to overheat.

The coolant level **must** be checked daily.

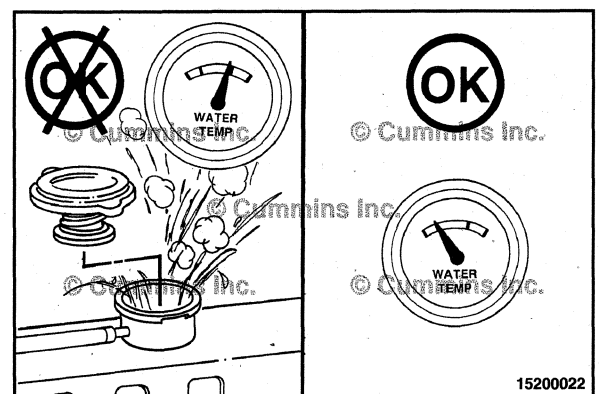

Maintenance Procedures - Overview

General Information

All maintenance checks and inspections listed in previous maintenance intervals **must** also be performed at this time, in addition to those listed under this maintenance interval.

Fuel Filter (Spin-On Type)

General Information

CAPS Fuel System

The CAPS fuel system requires the use of a single fuel filter. The filter **must** have the following characteristics:

- water-separating
- 10-micron rating
- water-in-fuel sensor
- water-drain valve
- engine mounted or chassis mounted.

Fleetguard® FS1022 meets these requirements.

Cummins Common Rail Fuel System

The Cummins Common Rail fuel system requires the use of two fuel filters. The suction side filter **must** have the following characteristics:

- water-separating
- 10-micron rating
- water-in-fuel sensor with shunt resistor
- water-drain valve
- **always** chassis mounted.

Fleetguard® FS1003 meets these requirements.

Racor model 1000MA meets these requirements for marine applications.

The pressure side filter **must** have the following characteristics:

- 2-micron rating
- engine mounted or chassis mounted.

Fleetguard® FF5488 meets these requirements.

The fuel supply and return valves **must** be closed when servicing the fuel filters on marine applications.

Refer to Procedure 100-001 in Section E for Engine Identification. The CM554 engine uses the CAPS fuel system. The CM850 engine uses the Cummins Common Rail fuel system.

Operate the engine and check for coolant leaks.

After the air has been purged from the system, check the coolant level again.

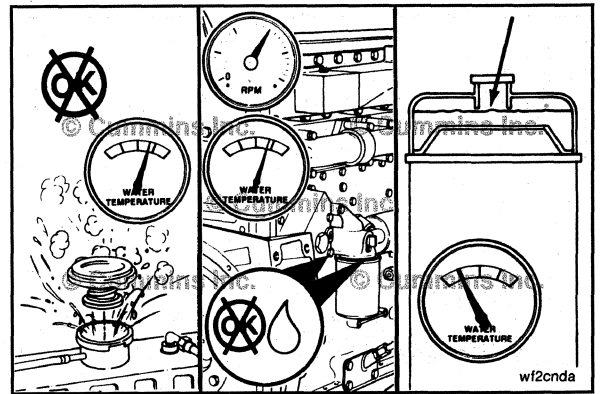

Batteries

Inspect

Use an inductive charging and cranking system analyzer to load-test the state of charge of maintenance-free batteries. If the state of charge is low, use a battery charger to charge the battery. Refer to the manufacturer's instructions.

Replace the battery if it will **not** charge to the manufacturer's specifications or the battery will **not** maintain a charge.

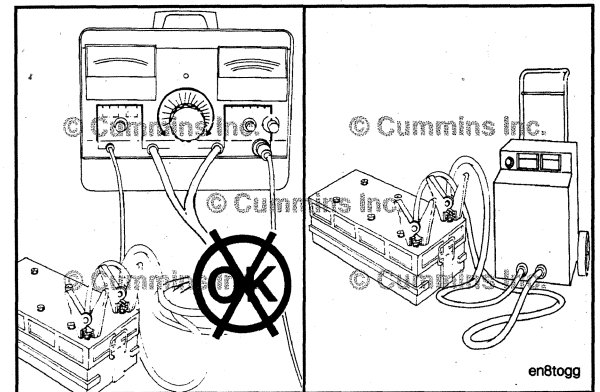

If conventional batteries are used, remove the cell caps or covers and check the electrolyte (water and sulfuric acid solution) level.



⚠ WARNING ⚠

Batteries can emit explosive gas. To reduce the possibility of personal injury, always ventilate the compartment before servicing the batteries. To reduce the possibility of arcing, remove the battery (-) negative cable first and attach the battery negative cable last.

NOTE: Maintenance-free batteries are sealed and do not require the addition of water.

Fill each battery cell with water. Refer to the manufacturer's specifications.

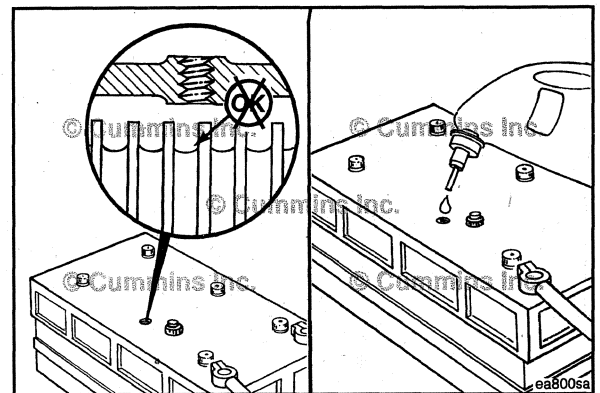

Refer to the accompanying table to determine the battery state of charge based on the specific-gravity readings.

Battery State of Charge	Specific Gravity @ 27°C [80°F]
100%	1.260 to 1.280
75%	1.230 to 1.250
50%	1.200 to 1.220
25%	1.170 to 1.190
Discharged	1.110 to 1.130

Section 7 - Maintenance Procedures at 2000 Hours or 2 Years

Section Contents

	Page
Air Compressor Discharge Lines	7-6
General Information.....	7-6
Maintenance Check.....	7-6
Cooling System	7-1
Drain.....	7-1
Fill.....	7-3
Flush.....	7-2
Engine Mounting Bolts	7-8
Maintenance Check.....	7-8
Engine Steam Cleaning	7-6
Clean.....	7-6
Maintenance Procedures - Overview	7-1
General Information.....	7-1
Radiator Hoses	7-6
Maintenance Check.....	7-6
Vibration Damper, Rubber	7-5
Inspect for Reuse.....	7-5
Vibration Damper, Viscous	7-5
Inspect.....	7-5

Section 8 - Maintenance Procedures at 5000 Hours or 4 Years

Section Contents

	Page
Engine Brake	8-4
Adjust.....	8-4
Finishing Steps.....	8-8
Center Bolted Rocker Lever Cover.....	8-8
Perimeter Bolted Rocker Lever Cover.....	8-9
Preparatory Steps.....	8-4
Maintenance Procedures - Overview	8-1
General Information.....	8-1
Overhead Set	8-1
Adjust.....	8-1
Finishing Steps.....	8-3
Center Bolted Rocker Lever Cover.....	8-3
Perimeter Bolted Rocker Lever Cover.....	8-3
Preparatory Steps.....	8-1

Tighten the capscrews.

Torque Value: 12 N•m [106 in-lb]

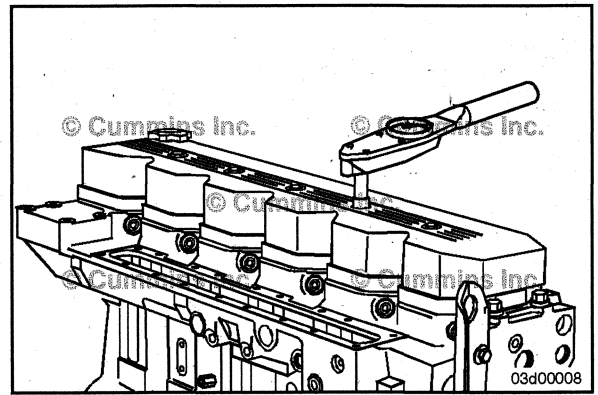

Perimeter Bolted Rocker Lever Cover

NOTE: If the gasket has been removed from the rocker lever cover, a new gasket **must** be used.

The following installation procedure **must** be used when installing the press-in gasket.

1. Press the molded gasket into the corners of the rocker lever cover.
2. Press the gasket around the capscrew mounting holes.
3. Press the remaining gasket into the rocker lever cover.

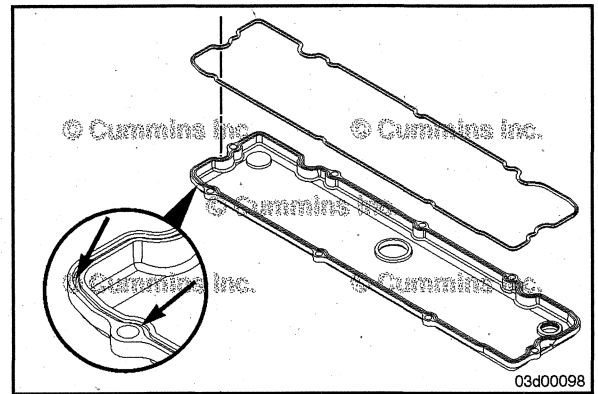

Install the rocker lever cover and capscrews.

Torque Value: 12 N•m [106 in-lb]

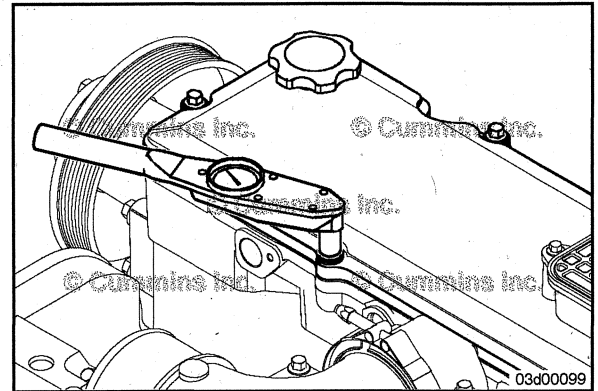

Install the crankcase breather tube, rocker lever cover mounted breather **only**.

Install the variable geometry turbocharger actuator air supply line, if equipped.

Install fluke digital thermometer, Part Number 3822666, into the intake manifold at the 1/8-inch NPT tap near the air horn connection with the intake manifold.



Another alternative is to use the monitor mode on the INSITE™ electronic service tool.

Install another thermocouple at the air cleaner inlet to measure ambient air temperature.

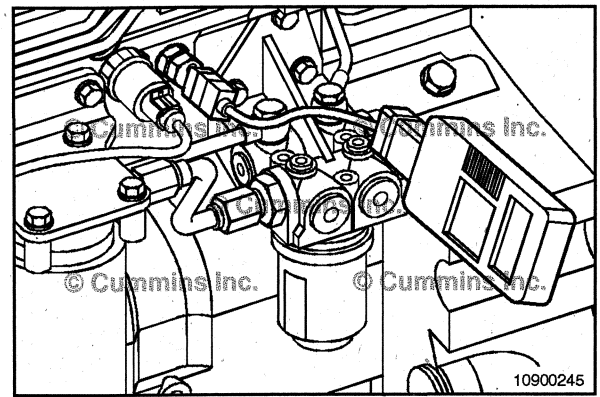

Perform a road test with the engine at peak power and a vehicle speed of 48 kph [30 mph] or greater.



Record the intake manifold temperature and the ambient air temperature.

Calculate the differential temperature:

- Intake Manifold Temperature minus Ambient Air Temperature equals Differential Temperature
- Maximum Differential Temperature equals 28°C [50°F].

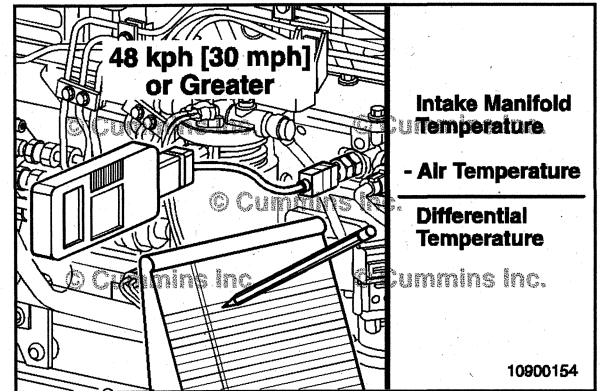

If the temperature differential is greater than the specifications, check the charge air cooler for dirt and debris on the fins and clean as necessary. If the problem still exists, check the charge air cooler for debris in the fins or between the charge air cooler and radiator. Confirm full fan engagement.

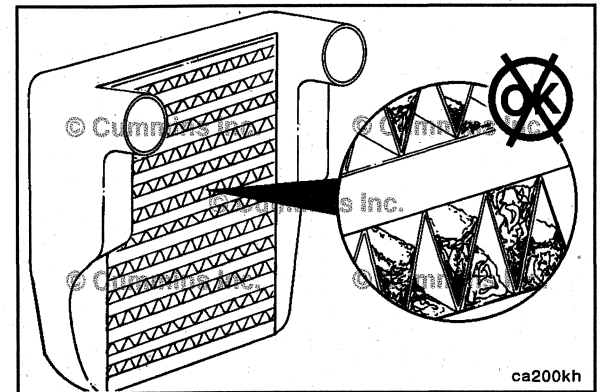



Flow Diagram, Fuel System

General Information

1. Fuel from supply tank
2. Electronic lift pump
3. Fuel filter and water separator
4. Fuel drain line
5. CAPS injection pump
6. Distributor outlet fitting
7. High-pressure supply lines
8. Fuel connector
9. Injectors
10. Fuel return to supply tank



CLICK HERE TO **DOWNLOAD** THE COMPLETE MANUAL

- Thank you very much for reading the preview of the manual.
- You can download the complete manual from: www.heydownloads.com by clicking the link below



- Please note: If there is no response to CLICKING the link, please download this PDF first and then click on it.

CLICK HERE TO **DOWNLOAD** THE COMPLETE MANUAL



Flow Diagram, Cooling System

General Information

1. Turbocharger coolant supply
2. Turbocharger coolant drain



Cummins Customized Parts Catalog

General Information

Cummins is pleased to announce the availability of a parts catalog compiled specifically for you. Unlike the generic versions of parts catalogs that support general high volume parts content; Cummins Customized catalogs contains only the new factory parts that were used to build your engine.

The catalog cover, as well as the content, is customized with you in mind. You can use it in your shop, at your worksite, or as a coffee table book in your RV or boat. The cover contains your name, company name, address, and telephone number. Your name and engine model identification even appears on the catalog spine. Everybody will know that Cummins created a catalog specifically for you.

This new catalog was designed to provide you with the exact information you need to order parts for your engine. This will be valuable for customers that do not have easy access to the Cummins Electronic Parts Catalog or the Cummins Parts Microfilm System.

Additional Features of the Customized Catalog include:

- Engine Configuration Data
- Table of Contents
- Separate Option and Parts Indexes
- Service Kits (when applicable)
- ReCon Part Numbers (when applicable)

Ordering the Customized Parts Catalog

Ordering by Telephone

North American customers can contact their Cummins Distributor or call Gannett Direct Marketing Services at 1-800-646-5609 and order by credit card. Outside North America order on-line or make an International call to Gannett at (+ +)502-454-6660.

Ordering On-Line

The Customized Parts Catalog can be ordered On-Line from the Cummins Powerstore by credit card. Contact the Powerstore at WWW.POWERSTORE.CUMMINS.COM

Contact GDMS or the CUMMINS POWERSTORE for the current price; Freight may be an additional expense.

Information we need to take your Customized Parts Catalog Order. This information drives the cover content of the CPC.

- Customer Name
- Street Address
- Company Name (optional)
- Telephone no.
- Credit Card No.
- Cummins Engine Serial Number (located on the engine data plate)
- Please identify the required media: Printed Catalog, CD-ROM, or PDF File

Unfortunately not all Cummins Engines can be supported by this parts catalog. Engines older than 1984 or newer than 3 months may not have the necessary parts information to compile a catalog. We will contact you if this occurs and explain why we are unable to fill your order.

Customized Parts Catalogs are produced specifically for a single customer. This means they are not returnable for a refund. If we make an error and your catalog is not useable, we will correct that error by sending you a new catalog.

Routine Service and Parts

General Information

Personnel at Cummins Authorized Repair Locations can assist you with the correct operation and service of your engine. Cummins has a worldwide service network of more than 5,000 Distributors and Dealers who have been trained to provide sound advice, expert service, and complete parts support. Check the telephone directory yellow pages or refer to the directory in this section for the nearest Cummins Authorized Repair Location.

Emergency and Technical Service

General Information

The Cummins Customer Assistance Center provides a 24-hour, toll free telephone number to aid in technical and emergency service when a Cummins Authorized Repair Location can **not** be reached or is unable to resolve an issue with a Cummins product.

If additional assistance is required, call Toll-Free:

1-800-DIESELS
(1-800-343-7357)

- Includes all 50 states, Bermuda, Puerto Rico, Virgin Islands, and the Bahamas.
- Outside of North America contact your Regional Office. Telephone numbers and addresses are listed in the International Directory.

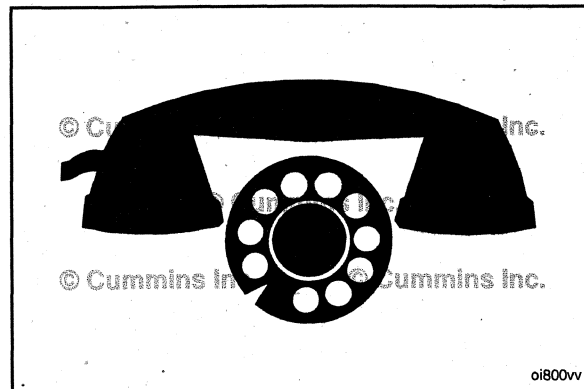

Problem Solving

General Information

Normally, any problem that arises with the sale, service, or repair of your engine can be handled by a Cummins Authorized Repair Location in your area. Refer to the telephone directory yellow pages for the one nearest you. If the problem has **not** been handled satisfactorily, follow the steps outlined below:

1. If the disagreement is with a Dealer, talk to the Cummins Distributor with whom he has his service agreement.
2. If the disagreement is with a Distributor, call the nearest Cummins Division or Regional Office; however, most problems are solved below the Division or Regional office level. Telephone numbers and addresses are listed in this section. Before calling, write down the following information:
 - a. Engine model and serial number
 - b. Type and make of equipment
 - c. Total kilometers [miles] or hours of operation
 - d. Warranty start date
 - e. Nature of problem
 - f. Summary of the current problem arranged in the order of occurrence
 - g. Name and location of the Cummins Distributor or Dealer
12. If a problem can **not** be resolved satisfactorily through your Cummins Authorized Repair Location or Division Office, write to:

Cummins Customer Assistance Center - 41403, Cummins Inc., Box 3005, Columbus, IN 47202-3005

Michigan	Standby Power - (Branch of Detroit)	Cummins Michigan, Inc. 12130 Dixie Redford, MI 48239 Telephone: (313) 538-0200 FAX: (313) 538-3966
Minnesota	St. Paul Distributor	Cummins North Central, Inc. 3030 Centre Pointe Drive Suite 500 Roseville, MN 55113 Telephone: (651) 636-1000 FAX: (651) 638-2442
Minnesota	Duluth Branch	Cummins Diesel Sales, Inc. 3115 Truck Center Drive Duluth, MN 55806-1786 Telephone: (218) 628-3641 FAX: (218) 628-0488
Minnesota	St. Paul Branch	Cummins North Central, Inc. 2690 Cleveland Ave. North St. Paul, MN 55113 Telephone: (651) 636-1000 FAX: (651) 638-2497
Mississippi	Jackson - (Branch of Memphis)	Cummins Mid-South, Inc. 325 New Highway 49 South Jackson, MS 39288-4224 Telephone: Admin.: (601) 932-7016 Parts: (601) 932-2720 Service: (601) 939-1800 FAX: (601) 932-7399
Missouri	Kansas City Distributor and Branch	Cummins Mid-America, Inc. 8201 NE Parvin Road Kansas City, MO 64161 Telephone: (816) 414-8200 FAX: (816) 414-8299
Missouri	Joplin Branch	Cummins Mid-America, Inc. 3507 East 20th Street Joplin, MO 64801 Telephone: (417) 623-1661 FAX: (417) 623-1817
Missouri	Springfield Branch	Cummins Mid-America, Inc. 3637 East Kearney Springfield, MO 65803 Telephone: (417) 862-0777 FAX: (417) 862-4429
Missouri	St. Louis Distributor	Cummins Gateway, Inc. 7210 Hall Street St. Louis, MO 63147 Telephone: (314) 389-5400 FAX: (314) 389-9671
Missouri	Columbia Branch	Cummins Gateway, Inc. 5221 Highway 763 North Columbia, MO 65202 Telephone: (314) 449-3711 FAX: (314) 449-3712

Distributors and Branches - Canada

Alberta	Edmonton Distributor and Branch	Cummins Alberta 11751 - 181 Street Edmonton, AB T5S 2K5 Telephone: (780) 455-2151 FAX: (780) 454-9512
Alberta	Calgary Branch	Cummins Alberta 4887 - 35th Street S.E. Calgary, Alberta T2B 3H6, Canada Telephone: (403) 569-1122 FAX: (403) 569-0027
Alberta	Grande Prairie	Cummins Alberta - Grande Praire RR2, Site 9, Box 22 Sexsmith, AB CN T0H 3C0 Telephone: (780) 568-3359 FAX: (780) 568-2263
Alberta	Hinton Branch	Cummins Alberta 135 Veats Avenue Hinton, Alberta T7V 1S8, Canada Telephone: (780) 865-5111 FAX: (780) 865-5714
Alberta	Lethbridge Branch	Cummins Alberta 240 - 24th Street North Lethbridge, Alberta T1H 3T8, Canada Telephone: (403) 329-6144 FAX: (403) 320-5383
British Columbia	Vancouver Distributor	Cummins British Columbia 18452 - 96th Avenue Surrey, B.C., Canada V4N 3P8 Telephone: (604) 882-5000 FAX: (604) 882-5080
British Columbia	Kamloops Branch	Cummins British Columbia 976 Laval Crescent Kamloops, B.C. Canada V2C 5P5 Telephone: (250) 828-2388 FAX: (250) 828-6713
British Columbia	Prince George Branch	Cummins British Columbia 102- 3851- 18th Avenue Prince George, B.C. V2N 1B1 Telephone: (250) 564-9111 FAX: (250) 564-5853
British Columbia	Sparwood Branch	Cummins British Columbia 731 Douglas Fir Road Sparwood, B.C. VOB 2G0, Canada Telephone: (250) 425-0522 FAX: (250) 425-0323
British Columbia	Tumbler Ridge Branch	Cummins British Columbia Industrial Site, Box 226 Tumbler Ridge, B.C. Canada VOC 2WO Telephone: (250) 242-4217 FAX: (250) 242-4906

Milan Regional Office - Italy	
Cummins Diesel Italia S.P.A. Piazza Locatelli 8 Zona Industriale 20098 San Giuliano Milanese Milan, Italy Telephone: (+ 39-02) 98-83-111	
Country Covered: Italy	

North Asia Regional Office - Japan	
Cummins Diesel Sales Corporation 1-12-10 Shintomi Chuo-ku, Tokyo 104 Japan Telephone: (81-3) 3555-3131/2/3/4/5	
Country Covered: Japan	

Seoul Regional Office - Korea	
Cummins Korea Ltd. 5th Floor, Hye Sung Building 35-26 Sam Sung Dong, Kang Nam Ku Seoul, South Korea Telephone: (82-2) 516-0431/2/3, 517-3370/1	
Country Covered: South Korea	

Cummsa Regional Office - Mexico	
Cummins, S.A. de C.V. Arquimedes No. 209 Col. Polanco 11560 Mexico, D.F. Mexico Telephone: (52-5) 254-3822/3783/3622	Mailing/Shipping Address: Gonzalez de Castilla Inc. P.O. Box 1391 4605 Modern Lane Modern Industrial Park Laredo, TX 78040 Telephone: (512) 722-5207
Country Covered: Mexico	

CYPRUS	Nicosia	Alexander Dimitriou & Sons Ltd. P.O. Box 21932 Nicosia, Cyprus CY-1515 Location: 4 Salamis Avenue Telephone: (357-2) 349450
CZECH REPUBLIC		- See Austrian Distributor
DENMARK	Glostrup	Cummins Diesel Salg & Service A/S Hovedvejen 233B Osted DK-4000 Roskilde Denmark Telephone: (45-46) 423 552
DJIBOUTI		- See North/West/East and Central Africa
DOMINICA	Miami (Office in U.S.A.)	Cummins Southeastern Power, Inc. 9900 N.W. 77 Court Hialeah Gardens, FL 33016 Telephone: (305) 821-4200
DOMINICAN REPUBLIC	Santo Domingo	Argico C. Por A. P.O. Box 292-2 Feria Santo Domingo Dominican Republic, ZP-6 Location: Calle Jose A. Soler No. 3, ESQ. Avenida Lope de Vega Telephone: (809) 562-6281
DUBAI		- See United Arab Emirates
ECUADOR	Guayaquil	Motores Cummins (MOTCUM) S.A. P.O. Box 1062 Guayaquil, Ecuador Location: Avenida Carlos Julio Arosemena Km. 4 Telephone: (593-4) 203995/201177
ECUADOR	Quito	Rectificadora Botar S.A. P.O. Box 17-01-3344 Quito, Ecuador Location: Av. 10 de Agosto No. 5980 Telephone: (593-2) 465-176/177/ 178/195/197
EGYPT	Cairo	ADAT P.O. Box 1572 Cairo, Egypt Sales and Service Location: 25, Pyramid Road Giza, Cairo, Egypt Telephone: (20-2) 385-4001/2/4/5/6/8/9

SAUDI ARABIA	Al-Khobar	GCC Olayan P.O. Box 356 Al-Khobar 31952 Saudi Arabia Telephone: (966-3) 882-0888
SCOTLAND		- See United Kingdom
SENEGAL	Dakar	Matforce B.P. 397. Dakar, Senegal Location: 10 Avenue Faidherbe Telephone: (221-8) 399500 Fax: (221-8) 399531/399550 Equipements et Services (Mining Only) BP 15372-Fann Dakar Senegal Contacts: Mr. Jean Smets Tel: (221-8) 60 77 76 & 24 73 62 Fax: (221-8) 60 95 98
SEYCHELLES		- See North/West/East & Central Regional Office - Daventry
SIERRA LEONE		- See North/West/East and Central Africa Regional Office - Daventry
SINGAPORE	Singapore	Applied Diesel Sales & Service Pte Ltd 8 Tanjong Penjuru Jurong Industrial Estate Singapore 2260 Telephone: (65) 261-3555
SLOVAKIA		- See European Regional Office - Gross-Gerau
SOLOMON ISLANDS		- See South Pacific Regional Office - Melbourne
SOMALIA		- See East and Southern Africa Regional Office - Harare
SOUTH AFRICA	Johannesburg	Cummins Diesel South Africa Pty. Ltd. Private Bag X7 Wendywood 2144 South Africa Location: 13 Eastern Service Road Kelvin View 2054 Telephone: (27-11) 321 8700
SOUTHWEST AFRICA		- See Namibia
SPAIN	Madrid	Cummins Ventas y Servicio S.A. Torrelaguna, 56 28027 Madrid, Spain Telephone: (34-91) 367-2000/3672404
SPANISH GUINEA		- See Spain

Air Compressor Noise is Excessive

Cause

Correction

STEP 1

Carbon buildup is excessive in the air discharge line, check valve, or cylinder head

Check for carbon buildup. Replace the air compressor discharge line, if necessary. Refer to Procedures 012-014 and 010-033.

OK

Go To Next Step

STEP 2

Ice buildup in the air system components

For all models, check for ice in low spots of the air discharge line, dryer inlet, and elbow fittings. On Holset® models, also check the Econ valve (if equipped). Refer to the OEM instructions.

OK

Go To Next Step

STEP 3

Air compressor mounting hardware is loose, worn, or broken

Check air compressor mounting hardware. Refer to Procedure 012-014.

OK

Go To Next Step

STEP 4

Air compressor is sending air pulses into the air tanks

Install a ping tank between the air dryer and the wet tank. Refer to the OEM instructions.

OK

Go To Next Step

STEP 5

Contact a Cummins Authorized Repair Facility

Coolant Temperature Above Normal - Gradual Overheat

Cause

Correction

STEP 18

Torque converter cooler or hydraulic oil cooler is malfunctioning

Remove and inspect the cooler cores and o-rings. Refer to the OEM service manual.

OK

Go To Next Step

STEP 19

Vehicle cooling system is **not** adequate

Verify that the engine and vehicle cooling systems are using the correct components. Refer to the OEM service manual.

OK

Go To Next Step

STEP 20

Engine is overfueled

Check the engine fuel rate. Refer to the Fuel Consumption Excessive symptom tree.

OK

Go To Next Step

STEP 21

Contact a Cummins Authorized Repair Facility

Engine Noise Excessive

Cause

Correction

STEP 1

Fan drive belt is loose

Check the belt tension and tighten if necessary.

OK

Go To Next Step

STEP 2

Fan is loose, damaged, or **not** balanced

Check the fan. Refer to Procedure 008-040.

OK

Go To Next Step

STEP 3

Fan clutch, hydraulic pump, or refrigerant compressor noise is excessive

Isolate each component and check for noise. Refer to the OEM service manual.

OK

Go To Next Step

STEP 4

Air intake or exhaust leaks

Check for loose or damaged piping connections and missing pipe plugs. Check the turbocharger and exhaust manifold mounting. Refer to Procedure 010-033.

OK

Go To Next Step

STEP 5

Air intake or exhaust piping is contacting the chassis or cab

Inspect the air piping, chassis, and cab for contact points. Refer to the OEM service manual.

OK

Go To Next Step

STEP 6

Lubricating oil level is above or below specification

Check the oil level. Add or drain oil, if necessary. Refer to Procedure 007-043.

OK

Go To Next Step

STEP 7

Lubricating oil is thin or diluted

Refer to Lubricating Oil Contaminated symptom tree.

OK

Go To Next Step

STEP 8

Lubricating oil pressure is below specification

Check the oil pressure. If the pressure is low, refer to Lubricating Oil Contaminated symptom tree.

OK

Go To Next Step

STEP 9

Vibration damper is damaged

Inspect the vibration damper. Refer to Procedure 001-051 or 001-052.

OK

Go To Next Step

STEP 10

Coolant temperature is above specification

Refer to the Coolant Temperature Above Normal - Gradual Overheat symptom tree.

OK

Go To Next Step

Engine Speed Surges in PTO or Cruise Control

Cause

Correction

STEP 1

Engine speed also surges at idle

Refer to Engine Speed Surges at Low or High Idle symptom tree.

OK

Go To Next Step

STEP 2

Engine speed surges while in the normal operating range and **not** in PTO or cruise control

Refer to Engine Speed Surges Under Load or in Operating Range symptom tree.

OK

Go To Next Step

STEP 3

Electronic fault codes are active

For instructions on how to read active fault codes, refer to Diagnostic Fault Codes Procedure 101-007. If fault codes are active, contact a Cummins Authorized Repair Facility.

OK

Go To Next Step

STEP 4

Moisture in the wiring harness connectors

Dry the connectors with Cummins electronic cleaner, Part Number 3824510.

OK

Go To Next Step

STEP 5

Contact a Cummins Authorized Repair Facility

Fuel in the Lubricating Oil

Cause

Correction

STEP 1
Bulk oil supply is contaminated

Check the bulk oil supply. Drain the oil and replace with noncontaminated oil. Replace the oil filters.

OK
Go To Next Step

STEP 2
Engine idle time is excessive

Low oil and coolant temperatures can be caused by long idle time (greater than 10 minutes). Shut off the engine rather than idle for long periods. If idle time is necessary, raise the idle speed.

OK
Go To Next Step

STEP 3
Contact a Cummins Authorized Repair Facility

Turbocharger Leaks Engine Oil or Fuel

Cause

Correction

STEP 1

Engine is operating for extended periods under light- or no-load conditions (slobbering)

Review the engine operating instructions in Section 1.

OK

Go To Next Step

STEP 2

Air intake system restriction is above specification

Check the air intake system for restriction. Clean or replace the air filter and inlet piping as necessary. Refer to Procedure 010-058.

OK

Go To Next Step

STEP 3

Exhaust system restriction is **not** within specification

Check the exhaust system for restrictions. Contact a Cummins Authorized Repair Facility.

OK

Go To Next Step

STEP 4

Lubricating oil lines leak oil

Check all oil lines and fittings for leaks. Tighten loose fittings and replace leaking oil lines if necessary.

OK

Go To Next Step

STEP 5

Crankcase ventilation system is plugged

Check and clean the crankcase breather and vent tube. Refer to Procedure 003-018.

OK

Go To Next Step

STEP 6

Turbocharger oil seal is leaking

Check the turbocharger compressor and turbine seals. Contact a Cummins Authorized Repair Facility.

OK

Go To Next Step

STEP 7

Lubricating oil or fuel is entering the turbocharger

Remove the intake and exhaust piping, and check for oil or fuel.

OK

Go To Next Step

STEP 8

White smoke is present

Refer to the Smoke, White - Excessive symptom tree.

OK

Go To Next Step

STEP 9

Contact a Cummins Authorized Repair Facility

This Page Left Intentionally Blank



Drive Belt Tension

Tension Chart

SAE Belt Size	Belt Tension Gauge Part No.		Belt Tension New		Belt Tension Range Used*	
	Click-type	Burroughs	N	lbf	N	lbf
0.380 in	3822524		620	140	270 to 490	60 to 110
0.440 in	3822524		620	140	270 to 490	60 to 110
1/2 in	3822524	ST-1138	620	140	270 to 490	60 to 110
11/16 in	3822524	ST-1138	620	140	270 to 490	60 to 110
3/4 in	3822524	ST-1138	620	140	270 to 490	60 to 110
7/8 in	3822524	ST-1138	620	140	270 to 490	60 to 110
4 rib	3822524	ST-1138	620	140	270 to 490	60 to 110
5 rib	3822524	ST-1138	670	150	270 to 530	60 to 120
6 rib	3822525	ST-1293	710	160	290 to 580	65 to 130
8 rib	3822525	ST-1293	890	200	360 to 710	80 to 160
10 rib	3822525	3823138	1110	250	440 to 890	100 to 200
12 rib	3822525	3823138	1330	300	530 to 1070	120 to 240
12 rib K section	3822525	3823138	1330	300	890 to 1070	200 to 240

NOTE: This chart does not apply to automatic belt tensioners.

* A belt is considered used if it has been in service for ten minutes or longer.

* If used belt tension is less than the minimum value, tighten the belt to the maximum used belt value.

occurs first, as measured from the date of delivery of the Engine to the ultimate purchaser, or (B) The Base Engine Warranty.

If the vehicle in which the Engine is installed is registered in the state of California, a separate California Emission Warranty also applies.

Limitations

Failures, other than those resulting from defects in materials, or workmanship, are not covered by this warranty.

Cummins is not responsible for failures or damage resulting from what Cummins determines to be abuse or neglect, including, but not limited to: operation without adequate coolant or lubricants; overfueling; overspeeding; lack of maintenance of lubricating, cooling or intake systems; improper storage, starting, warm-up, run-in or shutdown practices; unauthorized modifications of the Engine. Cummins is also not responsible for failures caused by incorrect fuel or by water, dirt or other contaminants in the fuel.

Cummins is not responsible for non-Engine repairs, "downtime" expenses, cargo damage, fines, all business costs or other losses resulting from a Warrantable Failure.

CUMMINS IS NOT RESPONSIBLE FOR INCIDENTAL OR CONSEQUENTIAL DAMAGES.

* Includes American Samoa, the Commonwealth of Northern Mariana Islands, Guam, Puerto Rico, and the U.S. Virgin Islands.

** Alternators, starters, and fans ARE covered for the duration of the base engine warranty on A series and B3.3 engines.

CLICK HERE TO **DOWNLOAD** THE COMPLETE MANUAL

- Thank you very much for reading the preview of the manual.
- You can download the complete manual from: www.heydownloads.com by clicking the link below



- Please note: If there is no response to CLICKING the link, please download this PDF first and then click on it.

CLICK HERE TO **DOWNLOAD** THE COMPLETE MANUAL