





INDEX

1	Introduction	3
2	Specification	3
2.1	Technical specifications	3
2.2	Control unit	4
2.2.a	Microswitches	4
2.2.b	Accelerator unit	4
2.2.c	Other analog control unit	5
2.2.d	Speed feedback	5
2.3	Protection features 	6
2.4	Operational features	7
2.5	Diagnosis	8
2.6	Thermal consideration	8
2.7	General instructions and precautions 	8
2.8	Susceptibility and electromagnetic emission 	9
2.9	Main contactor and emergency switch	9
3	Safety and protection 	10
4	Installation	11
4.1	Connection cables	11
4.2	Contactors	11
4.3	Fuses	11
4.4	Description of connectors - Traction configuration	12
4.5	Description of connectors - Pump configuration	15
4.6	Encoder installation	18
4.7	Description of power connections	19
4.8	Mechanical drawing	20
4.9	Connection drawing - Traction configuration	21
4.10	Connection drawing - Pump configuration	22
4.11	Connection drawing - Combi configuration	23
5	Programming & Adjustments using Digital Console	24
5.1	Adjustments via Console	24
5.2	Description of Console & Connection	24
5.3	Description of Standard Console Menu	25
5.3.a	Traction configuration	25
5.3.b	Pump configuration	26
5.4	Function configuration	27
5.4.a	Traction	27
5.4.b	Pump	31
5.5	Parameter regulation: Traction configuration	37
5.6	Parameter regulation: Pump configuration	39
5.7	Programming console functions	41
5.8	Sequence for Ac Inverter Traction setting	42
5.9	Tester: description of the function; Traction configuration	43

CLICK HERE TO **DOWNLOAD** THE COMPLETE MANUAL

- Thank you very much for reading the preview of the manual.
- You can download the complete manual from: www.heydownloads.com by clicking the link below



- Please note: If there is no response to CLICKING the link, please download this PDF first and then click on it.

CLICK HERE TO **DOWNLOAD** THE COMPLETE MANUAL

4 INSTALLATION

Install the chopper with the base-plate on a flat metallic surface that is clean and unpainted. Apply a light layer of thermo-conductive grease between the two surfaces to permit better heat dissipation.

Ensure that the wiring of the cable terminals and connectors is carried out correctly. Fit transient suppression devices to the horn, solenoid valves, and contactors not connected to the chopper such as those for activating the pump motor or steering motor.

4.1 CONNECTION CABLES

For the auxiliary circuits, use cables of 0.5mm² section.

For power connections to the motor and to the battery, use cables having section of 35 mm² (as a minimum).

For the optimum inverter performance, the cables to the battery should be run side by side and be as short as possible.

4.2 CONTACTORS

The main contactor must be installed. Depending on the position of a jumper installed in the logic board:

- the output which drives the main contactor coil is on/off (the coil is driven with the full battery voltage).
- the output which drives the main contactor coil is switched at high frequency (1 KHz) with a duty cycle of 70%; this feature is useful to decrease the power dissipation of the contactor coil.

4.3 FUSES

- Use a 6.3A Fuse for protection of the auxiliary circuits.
- For protection of the power unit, refer to diagrams.. The Fuse value shown is the maximum allowable. For special applications or requirements these values can be reduced.
- For Safety reasons, we recommend the use of protected fuses in order to prevent the spread of fused particles should the fuse blow.

4.9 CONNECTION DRAWING - TRACTION CONFIGURATION

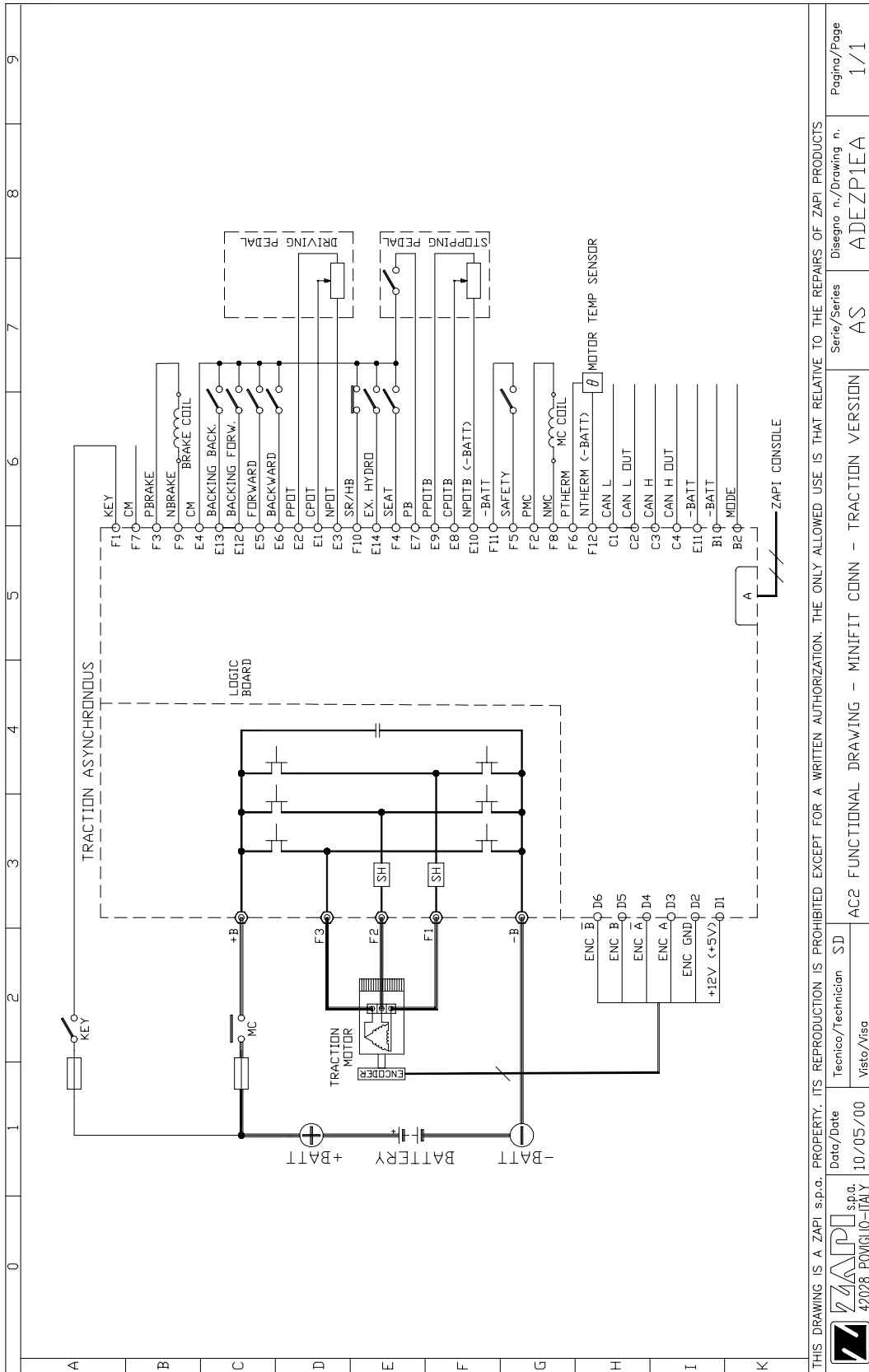

THIS DRAWING IS A ZAPI s.p.a. PROPERTY. ITS REPRODUCTION IS PROHIBITED EXCEPT FOR A WRITTEN AUTHORIZATION. THE ONLY ALLOWED USE IS THAT RELATIVE TO THE REPAIRS OF ZAPI PRODUCTS

	Data/Date 10/05/00	Tecnico/Technician SD	Serie/Series AS	Disegno n./Drawing n. ADEZPIEA	Pagina/Page 1/1
AC2 FUNCTIONAL DRAWING - MINIFIT CONN - TRACTION VERSION					

5.4.b Pump

Using the config menu of the programming console, the user can configure the following functions.

SUBMENU "SET OPTIONS"

1 HOUR COUNTER

- RUNNING: the counter registers travel time only.
- KEY ON: the counter registers when the "key" switch is closed.

2 BATTERY CHECK

- ON: the battery discharge level check is carried out; when the battery level reaches 10%, an alarm is signalled and the maximum current is reduced to the half of the programmed value.
- OFF: the battery discharge level check is carried out but no alarm is signalled.

Very important:

In the combi system (pump + traction), the battery discharge calculation for the complete system is carried out by the traction inverter; the information about the pump inverter consumption is sent on the can-bus line from the pump inverter to the traction inverter. So the correct programming for the "Battery check" option is :

- traction inverter: ON
- pump inverter: OFF

3 SET TEMPERATURE

- DIGITAL: a digital (ON/OFF) motor thermal sensor is connected to F6 input.
- ANALOG: an analog motor thermal sensor is connected to F6 (the curve can be customized on a customer request).
- NONE: no motor thermal sensor switch is connected.

SUBMENU "ADJUSTEMENT"

- 1 SET BATTERY TYPE: selects the nominal battery voltage;
- 2 ADJUST BATTERY: fine adjustment of the battery voltage measured by the controller.
- 3 ADJUSTMENT #04: this parameter determines the motor temperature level at which the "Motor temperature" alarm is signalled. The range is from 70°C to 160°C with 10°C steps. This parameter must be adjusted only if the "Set temperature" (menu "Set option") parameter is programmed "Analog".

5.7 PROGRAMMING CONSOLE FUNCTIONS

- Functional configuration (see 4.1 , 4.2 , 4.3 , 4.4)
- Parameter programming (see 4.5 , 4.6)
- Tester: the user can verify the state of the following parameters:

TRACTION	PUMP
motor voltage (%)	motor voltage (%)
frequency (Hz)	frequency (Hz)
encoder (Hz)	encoder (Hz)
slip value (Hz)	slip value (Hz)
current rms (A)	current rms (A)
temperature (°C)	temperature (°C)
motor temperature (°C)	motor temperature (°C)
accelerator (V)	accelerator (V)
forw. switch (ON/OFF)	lifting switch (ON/OFF)
back. switch (ON/OFF)	1st speed switch (ON/OFF)
inching forw. (ON/OFF)	2nd speed switch (ON/OFF)
inching back. (ON/OFF)	3rd speed switch (ON/OFF)
cutback switch (ON/OFF)	4th speed switch (ON/OFF)
brake switch (ON/OFF)	hydro speed req. (ON/OFF)
seat switch (ON/OFF)	voltage booster (V)
exclusive hydro (ON/OFF)	battery voltage (V)
hand brake (ON/OFF)	cos fi
voltage booster (%)	battery current (A)
battery voltage (V)	battery charge (%)
cos fi	
battery current (A)	
battery charge (%)	

- Save function (for storing data)
- Restore function (for loading parameters on another chopper)
- Display of the last 5 alarms including hour-meter value and temperature at the moment of the alarm.
- Accelerator range programming: records the minimum and maximum useful accelerator stroke values for both direction of running.
- See the console manual for a detailed description of function and parameters.

7 AC2 INVERTER DIAGNOSTIC - TRACTION CONFIGURATION

The alarms are signalled by a diagnostic LED.

1 blink:	logic failure ("WATCHDOG", "EEPROM KO", "LOGIC FAILURE #1", "LOGIC FAILURE #2", "LOGIC FAILURE #3", "CHECK UP NEEDED").
2 blinks:	running request on start-up or error in seat sequence or double direction request ("INCORRECT START", "HANDBRAKE", "FORW + BACK").
3 blinks:	phase voltage or capacitor charge failure ("CAPACITOR CHARGE", "VMN LOW", "VMN HIGH").
4 blinks:	failure in accelerator ("VACC NOT OK", "PEDAL WIRE KO").
5 blinks:	failure of current sensor ("STBY I HIGH").
6 blinks:	failure of contactor driver ("COIL SHORTED", "DRIVER SHORTED", "CONTACTOR DRIVER", "AUX OUTPUT KO", "CONTACTOR OPEN").
7 blinks:	excessive temperature ("HIGH TEMPERATURE", "MOTOR TEMPERATURE", "THERMIC SENSOR KO").
8 blinks:	failure detection from can-bus ("WAITING PUMP", "CAN-BUS KO").
long blink:	discharge battery ("LOW BATTERY")

7.1 ANALYSIS OF ALARMS DISPLAYED ON CONSOLE

1. WATCH DOG
The test is made in both running and standby. It is a self-diagnosing test within the logic. If an alarm should occur, replace the logic.
2. EEPROM KO
Fault in the area of memory in which the adjustment parameters are stored; this alarm inhibits machine operation. If the defect persists when the key is switched OFF and ON again, replace the logic. If the alarm disappears, remember that the parameters stored previously have been cancelled and replaced by the default values.
3. LOGIC FAILURE #1
This alarm signals that an undervoltage / overvoltage protection operation has occurred. Two possible reasons:
 - a. A real undervoltage / overvoltage situation happened.
 - b. Fault in the hardware section of the logic board which manages the overvoltage protection. Replace the logic card.
4. LOGIC FAILURE #2
Fault in the hardware section of the logic board which manages the phase's voltage feedback. Replace the logic board.



ELECTRONIC INDUSTRIAL DEVICES

42028 - POVIGLIO - (R.E.) - Via Parma, 59 - ITALIA

Tel. +39 0522 960050 (r.a.) - Fax +39 0522 960259 - e-mail: zapi@zapispa.it

AC2 INVERTER OPERATING HANDBOOK AND FUNCTION DESCRIPTION



AUX VOLTAGE #2	mV	2500	AUTO ADJUSTED
----------------	----	------	---------------

MAIN MENU

PARAMETER CHANGE

SPEED LIMIT		6
AUX FUNCTION 3		4
SENSIBILITY		1
AUX FUNCTION 2		4
CREEP SPEED		0
COMPENSATION		2
AUXILIARY TIME		2
ANTIROLLBACK	%	40

TESTER

DT	V	0,01
SET POINT POT	V	0,00
FEEDBACK POT	V	4,96
TEMPERATURE	°C	23
FREQUENCY	Hz	0,00
MOTOR VOLTAGE	%	0
ENC	%	0
ENC SPEED	Hz	1,85
ENDSTROKE CW		OFF +12V
ENDSTROKE ACW		OFF +12V
CW LIMIT LEVEL		OFF +12V
ACW LIMIT LEVEL		OFF +12V
BACKING F.		OFF GND
BACKING B.		OFF GND
CUTBACK SWITCH		OFF +VB
BRAKE SWITCH		OFF GND
AUTOMATIC REQ.		OFF GND
MM ALARM SWITCH		OFF +12V
SM ALARM SWITCH		OFF +12V

SAVE PARAM.

RESTORE PARAM

ALARMS

ZAPI MENU

SPECIAL ADJUSTMENT

SET TEMPERATURE

HARDWARE SETTING

MAXIMUM CURRENT	A	40
CAN BUS		PRESENT

PROGRAM VACC

MOTOR DATA

4 SYSTEM DESCRIPTION

4.1 MANUAL STEERING WITH TACHO-GENERATOR OR STEPPER MOTOR

This option uses a tacho-generator (or a stepper motor) attached to the steering wheel to convert the steering wheel rotation into an electrical signal. The control logic sets the steer servo-motor in motion at a speed that increases with the speed of the steering wheel. Steering sensitivity and maximum speed are adjustable by using the ZAPI hand held controller.

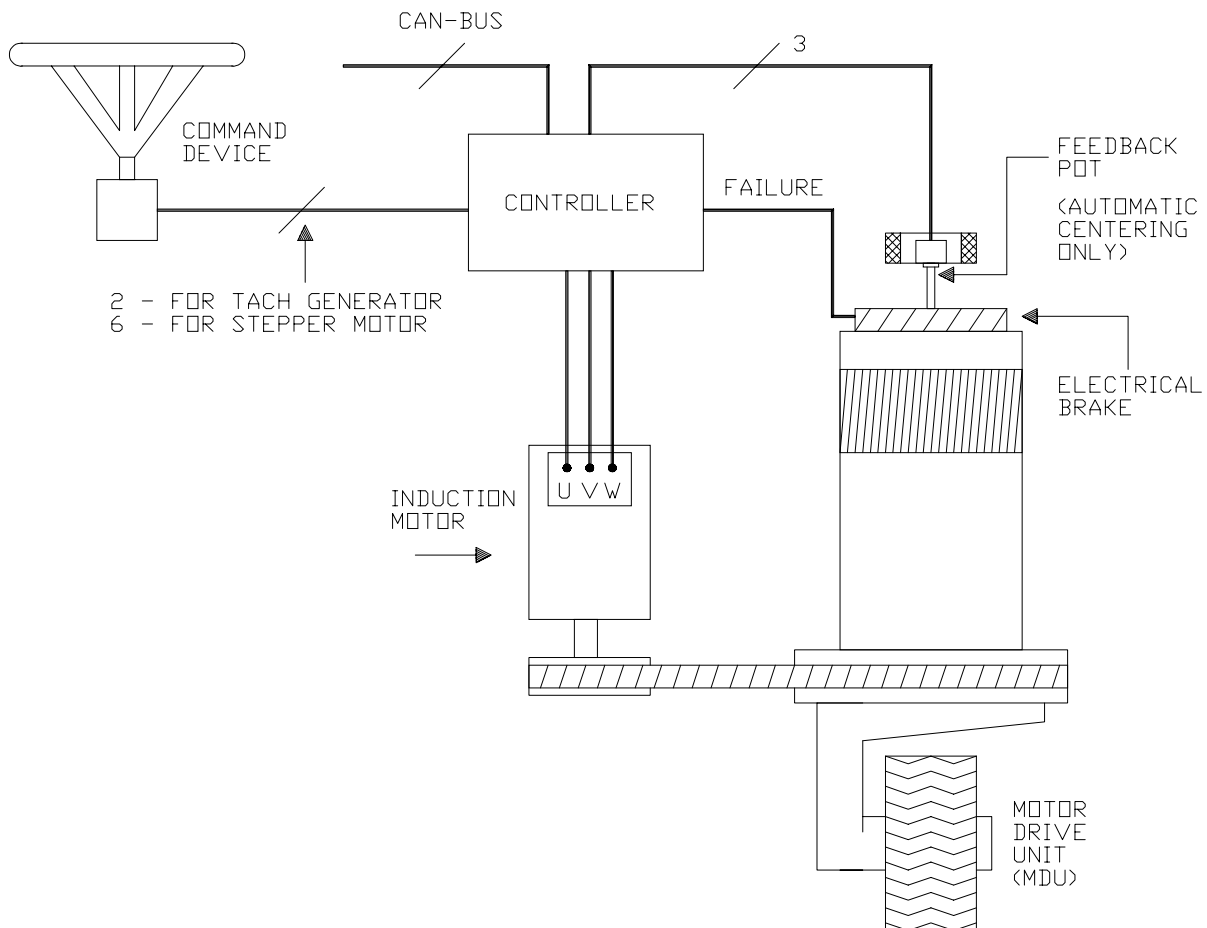

4.2 AUTOMATIC CENTERING

Through the AUTOSEL input request it is possible to turn the steering state from manual mode to automatic centering. The automatic centering request should be edge or level conditioned (see option AUT INP ACTIVE 10.7.7). As soon as an automatic centering request is recognized, the steering control will start to automatically rotate the MDU until it is straight ahead.

7 ONE SHOT INSTALLATION PROCEDURE

This section of the manual describes the connection procedure for the tacho-generator, the potentiometer and the motor.

Step 1 - STEERING WHEEL (COMMAND) DEVICE CONNECTIONS

Connect the two wires from the tacho-generator (or the two stepper motor lines) so that clockwise rotation of the steering wheel produces an increasing (higher positive) command value. This may be measured in two ways. Using the ZAPI hand held controller see the TESTER MENU' (see 10.6.1). The second way, (valid only for a tacho-generator application) is to use a DC voltmeter on the +DT (Pin #9 of CNB connector) and the minus terminal on the battery.

Step 2 - STEERING ANGLE FEEDBACK POT. CONNECTION

a) The steer angle feedback pot. has 3 wires: two end wires and a wiper wire. If the truck has a not leading MDU (Motor Drive Unit - see figure 7.1)* connect the two end wires to Pin #1 and #2 of connector CNA so when the Drive Unit is turned Counter-Clockwise (Clockwise for a truck with a leading MDU) the value on the wiper is increasing. This value may be measured in two ways. Use the Zapi hand held controller through the TESTER MENU' (see 10.6.3). The second way is to use a DC voltmeter connected to the steering angle feedback pot. wiper and battery negative. The wiper should be connected to Pin # 11 of connector CNA.

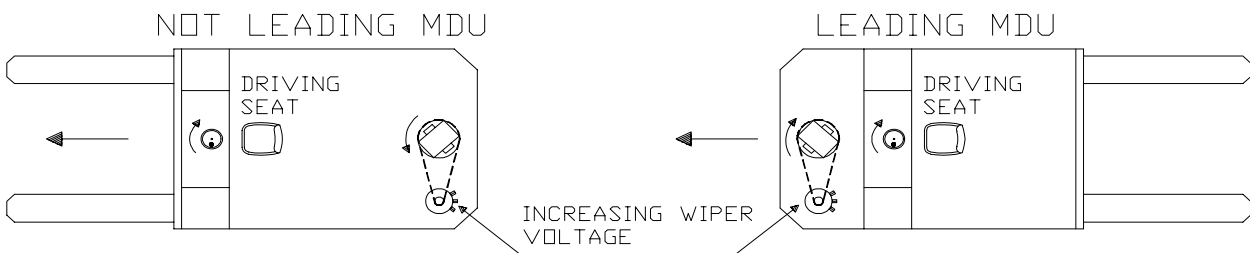

FIG. 7.1

* **Not leading MDU** : means the steering-traction wheel is opposite to the driving seat. When the steering handle is turned clockwise, the MDU turns counterclockwise.

Leading MDU : means the steering traction wheel is on the same side of the driving seat. When the steering handle is turned clockwise, the MDU turns clockwise too.

b) Physically adjust the steering angle feedback potentiometer so with the Drive Unit straight ahead, the wiper voltage is 2.5Vdc. The Zero Point for the steering angle feedback pot. can be adjusted using the ZAPI hand held controller. See the CONFIG MENU' (see. 10.8.1).

Step 3 - STEER MOTOR CONNECTIONS

Connect the three steering motor wires so that a Clockwise steering wheel movement causes a Counter-Clockwise steer movement, for a not leading MDU truck, or a Clockwise steer movement, for a leading MDU truck. If this operation is carried out correctly, the truck will turn Clockwise when the steering wheel is moved Clockwise while the truck is travelling in frontal direction (with respect to the driving seat).

Step 4 - LIMIT SWITCHES CONNECTION

After completing Steps 1 - 3, check that the limit switch connected to Pin #12 of connector CNB stops steering in the handwheel clockwise direction. Then, check that the limit switch connected to Pin # 6 stops steering in the Counter_Clockwise direction.

10.3 MAIN MENU "PARAMETERS LIST"

The parameters are slightly different between tacho-generator, tacho-generator with automatic centering and pot steering option. (the stepper motor application has the same hand set map as the tacho-generator configuration)

After modifying a parameter, memorize it with the hand set by pushing the "4" (OUT) button and the "3" (IN) button. Double pushing the OUT button exits without saving the modifications.

10.4 PARAMETERS IN SET MODEL 0 (TACHO-GENERATOR OR STEPPER MOTOR ONLY)

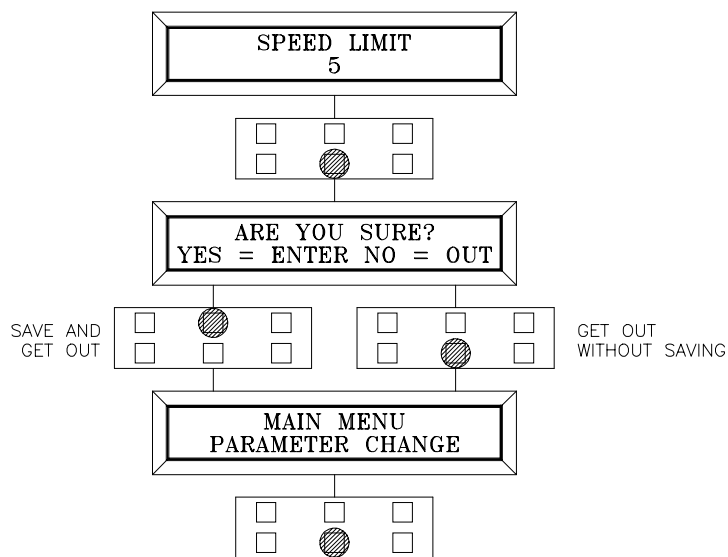

1) SPEED LIMIT

Regulates the MDU maximum turning speed.

- Level 0 is for slow turning.
- Level 9 is for fast turning.

Intermediate levels are for proportionally increasing speed settings. Maximum MDU speed has to be regulated after SET BATTERY TYPE is done (see JJ)

2) SENSIBILITY

It provides a non-linear relationship between MDU steering speed and tacho-generator voltage when low. This parameter produces increasing steering sensitivity with small changes in steering input.

- Level 0 is for steering response that is less sensitive to small steering wheel movements.
- Level 9 is for steering response that is very sensitive to small steering wheel movements.

Intermediate levels are for proportionally increasing speed setting. This parameter does not influence the maximum MDU steering rate.

CLICK HERE TO **DOWNLOAD** THE COMPLETE MANUAL

- Thank you very much for reading the preview of the manual.
- You can download the complete manual from: www.heydownloads.com by clicking the link below



- Please note: If there is no response to CLICKING the link, please download this PDF first and then click on it.

CLICK HERE TO **DOWNLOAD** THE COMPLETE MANUAL

10.9 CONFIG MENU: "SET MODEL"

This adjustment selects the steering configuration. For a tacho-generator (or a stepper motor) controlled steering the only permissible settings are 0 and 1:

- Level 0: tacho-generator (or stepper motor) steering
- Level 1: tacho-generator (or stepper motor) steering plus automatic centering
- Level 2: two pots manual steering (logic modification required)
- Level 3: two pots manual steering plus automatic centering (logic modification required)

Note: a new SET MODEL value will be acquired only after the key is switched off.

10.10 MAXIMUM CURRENT ADJUSTMENT

With the hand set it is possible to modify the maximum current setting. In order to modify it enter the ALARM CONFIG MENU. Push at the same time the two right side buttons. This sequence will enter the hidden ZAPI MENU. Roll up and down (buttons 1 and 2) until the "HARDWARE SETTING" appears on the hand set display. Enter it and change with the right side buttons the maximum current setting. Save the new setting before exiting. Switch off and on the key to acquire the new setting. It is important that the new maximum current value is compatible with the Eps_ac version you have.

12.5 SAFETY ON THE PRESENCE OF PHASE VOLTAGE WHEN THE STEERING MOTOR IS AT REST

The microprocessor logic continuously tests the phase voltage amplifiers output at rest and if they are other than $2.5V_{dc} \pm 0.25V_{dc}$, causes an alarm. These voltage are measured between D47 and D48 anodes and gnd (see Fig 11.1.6.2).

12.6 SAFETY ON POT WIRES BROKEN (FOR AUTOMATIC CENTERING OPERATION)

The safety on pot broken operates by looking for either higher than 4.7Vdc or less than 0.3Vdc on the wiper pin of the steer angle feedback pot. In fact, the 5K pot is connected with two resistances that confine its center point inside the two limits specified above if the pot is correctly connected (see Fig 11.1.3.1).

12.7 CROSS DIAGNOSIS BETWEEN MASTER AND SUPERVISOR MICROCONTROLLER

Each microcontroller independently reads the command input (tacho-generator or pot) and calculates a consequent controlling action. While the action generated by the Master becomes the executive, the supervisor's is just for a matching comparison. As each microcontroller receives both its own and the other microcontroller's value, if they are mismatched each microcontroller may open its own alarm switch.

B9	+12	Positive of the analog input N° 2 (+12V)
B10	PEVS	Positive of the electrovalve (safety)
B11	AN2	Analog input N° 2
B12	AN1	Analog input N° 1
B13	-BATT	Negative of the analog input N° 2
B14	NEV1	Negative of the ON-OFF electrovalve N° 1
B15	NEV3	Negative of the ON-OFF electrovalve N° 3
B16	PEV	Positive of the ON-OFF electrovalve N° 3

5.3 CONNECTOR CNC: AMP SAAB 6 POLES

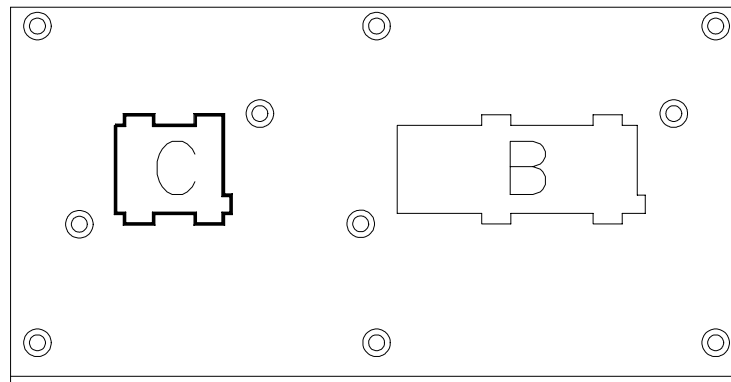

C1	PAUX	Positive supply for electrovalves
C2	PEVS	Positive supply for safety electrovalves
C3	CANL	CAN low signal
C4	KEY	Positive
C5	CANH	CAN high signal
C6	-BATT	Negative

6.10 DESCRIPTION OF THE TESTER FUNCTION

The most important input or output signals can be measured in real time using the TESTER function of the console. The Console acts as a multimeter able to read voltage, current and temperature. The following listing shows the measurements that may be made :

- 1) **DIGITAL INPUT 1:** indicate the state of the digital input 1 (CNA10). Options:
ON = active entry of closed switch (equal to battery positive potential)
OFF = inactive entry of open switch (equal to GND potential)
- 2) **DIGITAL INPUT 2:** indicate the state of the digital input 2 (CNA11). Options:
ON = active entry of closed switch (equal to battery positive potential)
OFF = inactive entry of open switch (equal to GND potential)
- 3) **DIGITAL INPUT 3:** indicate the state of the digital input 3 (CNA6). Options:
ON = active entry of closed switch (equal to battery positive potential)
OFF = inactive entry of open switch (equal to GND potential)
- 4) **DIGITAL INPUT 4:** indicate the state of the digital input 4 (CNA7). Options:
ON = active entry of closed switch (equal to battery positive potential)
OFF = inactive entry of open switch (equal to GND potential)
- 5) **DIGITAL INPUT 5:** indicate the state of the digital input 5 (CNA5). Options:
ON = active entry of closed switch (equal to battery positive potential)
OFF = inactive entry of open switch (equal to GND potential)
- 6) **DIGITAL INPUT 6:** indicate the state of the digital input 6 (CNA9). Options:
ON = active entry of closed switch (equal to battery positive potential)
OFF = inactive entry of open switch (equal to GND potential)
- 7) **DIGITAL INPUT 7:** indicate the state of the digital input 7 (CNA8). Options:
ON = active entry of closed switch (equal to battery positive potential)
OFF = inactive entry of open switch (equal to GND potential)
- 8) **DIGITAL INPUT 8:** indicate the state of the digital input 8 (CNB3). Options:
ON = active entry of closed switch (equal to battery positive potential)
OFF = inactive entry of open switch (equal to GND potential)
- 9) **EV 1:** indicate the state of the electrovalve 1 (CNA3). Options:
ON = active entry of closed switch (equal to battery positive potential)
OFF = inactive entry of open switch (equal to GND potential)
- 10) **EV 2:** indicate the state of the electrovalve 2 (CNA31). Options:
ON = active entry of closed switch (equal to battery positive potential)
OFF = inactive entry of open switch (equal to GND potential)
- 11) **EV 3:** indicate the state of the electrovalve 3 (CNA16). Options:
ON = active entry of closed switch (equal to battery positive potential)
OFF = inactive entry of open switch (equal to GND potential)
- 12) **EV 4:** indicate the state of the electrovalve 4 (CNA2). Options:
ON = active entry of closed switch (equal to battery positive potential)
OFF = inactive entry of open switch (equal to GND potential)

CAT

Controller: ZAPI MHYRIO 48V
Program version: MHYRIO RO 1.07
Zapi's serial number from:
Valve: Buchholz

Rev. 11
Date 02.15.05

CONFIG MENU

SET MODEL

SET OPTIONS

LIFT TYPE		OPTION #2
LOWER TYPE		OPTION #2
REACH FWD TYPE		OPTION #2
REACH BWD TYPE		OPTION #2
TILT UP TYPE		OPTION #2
TILT DW TYPE		OPTION #2
SHIFT RGT TYPE		OPTION #2
SHIFT LFT TYPE		OPTION #2

ADJUSTMENTS

MAIN MENU

PARAMETER CHANGE

MIN LIFT		30	255
MIN LOWER	A	33 0,15	255
MIN REACH FWD		30	255
MIN REACH BWD		30	255
MIN TILT UP		30	255
MIN TILT DW		30	255
MIN SHIFT RGT		30	255
MIN SHIFT LFT		30	255
MAX LIFT	A	160	255
MAX LOWER	A	120 0,61	150 0,77
			190 0,99
MAX REACH FWD		160	255
MAX REACH BWD		160	255
MAX TILT UP		160	255
MAX TILT DW		160	255

Defaults



Page 2

For having access to the "Page 2" is necessary to press the Enter button while is displayed the "Page 1".

```
tester 2

TRACTION ACCELERAT. =          4.27 VOLT
POTENTIOMETER #1 PU =          2.45 VOLT
POTENTIOMETER #2 PU =          2.47 VOLT
POTENTIOMETER #3 PU =          3.57 VOLT
POTENTIOMETER #4 PU =          2.48 VOLT
```

where:

TRACTION ACCELERAT. = traction potentiometer
POTENTIOMETER #1 PU = lifting/lowering potentiometer
POTENTIOMETER #2 PU = reach potentiometer
POTENTIOMETER #3 PU = tilting potentiometer
POTENTIOMETER #4 PU = side shift potentiometer

2.3.b Tester Slave

This is the tester menu of the Traction and Pump modules connected with the Sicos by the Can-Bus net. It shows the status of the inputs; it is composed by two pages.

Page 1

```
tester 1

CURRENT TRACTION      =          000 AMP
VOLTAGE TRACTION      =          000 %
FREQUENCY TRAC.      =          000 HERZ
TEMPERATURE TR.      =          000 GRADI
```

where:

CURRENT TRACTION = Traction inverter current (Arms)
VOLTAGE TRACTION = Traction inverter voltage (%)
FREQUENCY TRAC. = Traction inverter frequency (Hz)
TEMPERATURE TR.= Traction inverter temperature (°C)

CAT
Controller: ZAPI SICOS
Program version: SICOS RO 1.04-1.08
Zapi's serial number from:

Rev. 17
Date 31.3.2006

CONNECTION TYPE: 1	TRUCK TYPES:						OPTIONAL: HEIGHT DISPLAY	OPTIONAL: HEIGHT SELECTOR	OPTIONAL: SEAT SWITCH	DEFAULT	NOTE
	NR14XE	NR14K	NR16KC/KN	NR16K	NR20K	NR25KH					
MAIN MENU/ PARAMETER CHANGE:											
CUTBACK SPEED 1	0	0	0	0	0	0				0	
CUTBACK SPEED 2	0	0	0	0	0	0				0	creeper-speed, slow speed
1ST SPEED COARSE I	6	6	6	6	6	6				6	Lift I
1ST SPEED COARSE II	8	8	8	8	8	8				8	Lift II
1ST SPEED COARSE III	9	9	9	9	9	9				9	Lift III
5TH SPEED COARSE I	9	9	9	9	9	9				9	Lower I
5TH SPEED COARSE II	9	9	9	9	9	9				9	Lower II
5TH SPEED COARSE III	9	9	9	9	9	9				9	Lower III
2ND SPEED COARSE	5	4	4	4	4	4				6	Reach
3RD SPEED COARSE	3	3	3	3	4	4				3	Tilt
4TH SPEED COARSE	2	3	3	3	4	4				3	Side shift
MAX SPEED PU #5	5	5	5	5	5	5				0	Clamp-option
PUMP CREEP #1	0	0	0	0	0	0				0	
PUMP CREEP #2	0	0	0	0	0	0				0	
PUMP CREEP #3	0	0	0	0	0	0				0	
PUMP CREEP #4	0	0	0	0	0	0				0	
PUMP CREEP #5	0	0	0	0	0	0				0	Clamp-option
SPEED 2 CUTBACK	8	8	8	8	9	9				8	Reach slow
AUX SPEED #1	6	6	6	6	6	6				6	Auxiliary device
AUX SPEED #2	6	6	6	6	6	6				6	Auxiliary device
PUMP STOP DELAY	5	5	5	5	5	5				5	
LIFT CUTBACK	9	9	9	9	9	9				9	Lift speed reduction level
LOW CUTBACK	7	7	7	7	7	7				7	Lowering speed reduction level
ADJUSTMENT #01	5	5	5	5	5	5				5	Height for lift speed reduction
ADJUSTMENT #02	5	5	5	5	5	5				5	Height for lowering speed reduction
ADJUSTMENT #03	0	0	0	0	0	0				0	Height for retrieve level
ADJUSTMENT #04	0	0	0	0	0	0				0	Height for leave level
AUXILIARY TIME	0	0	0	0	0	0				0	
CONFIG MENU/ SET MODEL:											
CONNECTION TYPE	1	1	1	1	1	1				1	
SET OPTIONS:											
CHECK UP TYPE	0	0	0	0	0	0				0	
PERFORMANCE TYPE	2	2	2	2	2	2				2	
AUX.OUTPUT #1	0	0	0	0	0	0				0	Warning light output driver
HEIGHT DISPLAY	OFF	OFF	OFF	OFF	OFF	OFF	ON			OFF	
HOUR COUNTER	RUN	RUN	RUN	RUN	RUN	RUN				RUN	
BATTERY CHECK	ON	ON	ON	ON	ON	ON				ON	Disable lifting at low discharge
PRE-HEIGHT SEL.	OFF	OFF	OFF	OFF	OFF	OFF		ON		OFF	
CHECK UP DONE	OFF	OFF	OFF	OFF	OFF	OFF				OFF	
SEAT SWITCH	OFF	OFF	OFF	OFF	OFF	SWITCH			ON	OFF	
LOGO DISPLAY	OFF	OFF	OFF	OFF	OFF	OFF				OFF	
MEASURE SYS.TYPE	OP1	OP1	OP1	OP1	OP1	OP1				OP1	OP1=metric, OP2=anglo
AUX.FUNCTION #1	OFF	OFF	OFF	OFF	OFF	OFF				OFF	Short height select cycle
AUX.FUNCTION #2	ON	ON	ON	ON	ON	ON				ON	Enable height programming
AUX.FUNCTION #3	ON	OFF	OFF	OFF	OFF	OFF				OFF	ON=lift top limit (i-mast)
LIFT-LOWER STOP	OFF	OFF	OFF	OFF	OFF	OFF				OFF	ON=lift cage sensor enabled
5TH FUNCTION	OFF	OFF	OFF	OFF	OFF	OFF				OFF	ON=clamp-option
SIDESHIFT MODE											SICOSK 0.05
ADJUSTMENTS:											
MIN ACC LIFT	2,7	2,7	2,7	2,7	2,7	2,7				2,7	
MAX ACC LIFT	4,3	4,3	4,3	4,3	4,3	4,3				4,3	
MIN ACC LOW	2,1	2,1	2,1	2,1	2,1	2,1				2,1	
MAX ACC LOW	0,4	0,4	0,4	0,4	0,4	0,4				0,4	
MIN REACH BACK	2,7	2,7	2,7	2,7	2,7	2,7				2,7	
MAX REACH BACK	4,5	4,5	4,5	4,5	4,5	4,5				4,5	
MIN REACH FORW	2,1	2,1	2,1	2,1	2,1	2,1				2,1	
MAX REACH FORW	0,4	0,4	0,4	0,4	0,4	0,4				0,4	
MIN TILT UP	2,7	2,7	2,7	2,7	2,7	2,7				2,7	
MAX TILT UP	4,5	4,5	4,5	4,5	4,5	4,5				4,5	
MIN TILT DOWN	2,1	2,1	2,1	2,1	2,1	2,1				2,1	
MAX TILT DOWN	0,4	0,4	0,4	0,4	0,4	0,4				0,4	
MIN SHIFT RIGHT	2,7	2,7	2,7	2,7	2,7	2,7				2,7	
MAX SHIFT RIGHT	4,5	4,5	4,5	4,5	4,5	4,5				4,5	
MIN SHIFT LEFT	2,1	2,1	2,1	2,1	2,1	2,1				2,1	
MAX SHIFT LEFT	0,4	0,4	0,4	0,4	0,4	0,4				0,4	
MIN 5TH FORWARD	2,7	2,7	2,7	2,7	2,7	2,7				2,7	Clamp-option
MAX 5TH FORWARD	4,5	4,5	4,5	4,5	4,5	4,5				4,5	Clamp-option
MIN 5TH BACKWARD	2,1	2,1	2,1	2,1	2,1	2,1				2,1	Clamp-option
MAX 5TH BACKWARD	0,4	0,4	0,4	0,4	0,4	0,4				0,4	Clamp-option

11 12 13 14 15 16 17 18 19 20 21 22 23 24 25 26 27 28 29 30

LIFT/LOWER
R11

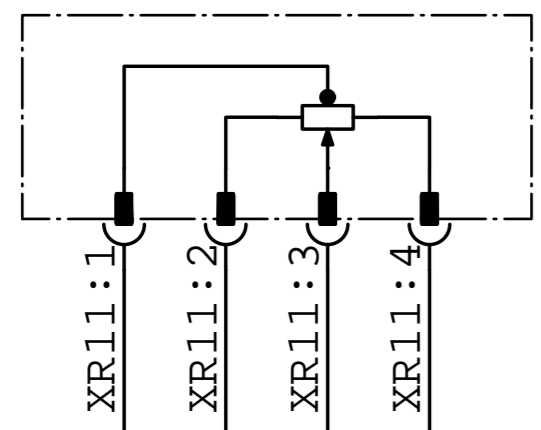

REACH
R12

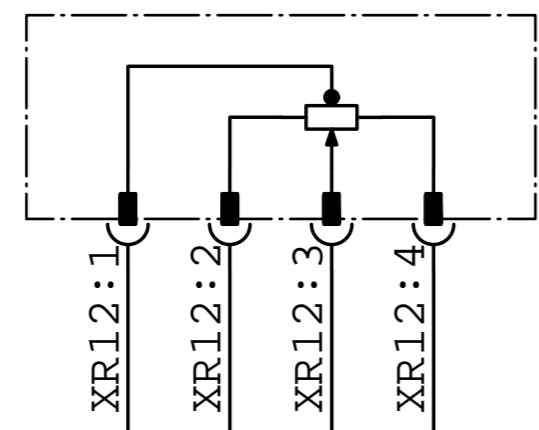

TILT
R13

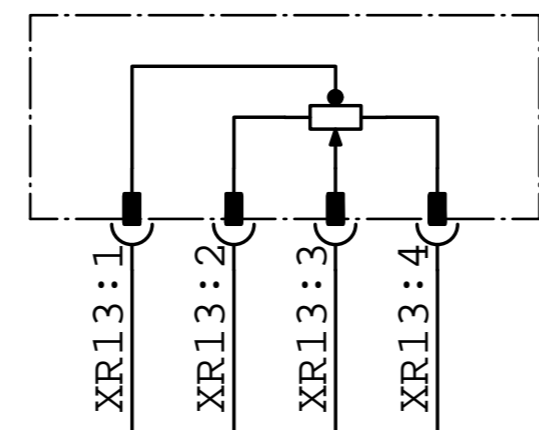

SIDESHIFT
R14

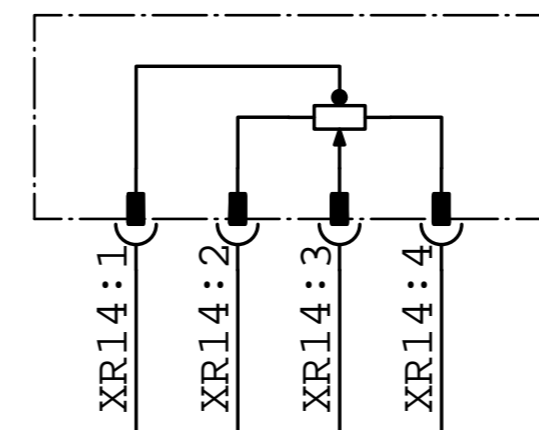

AUX DEVICE

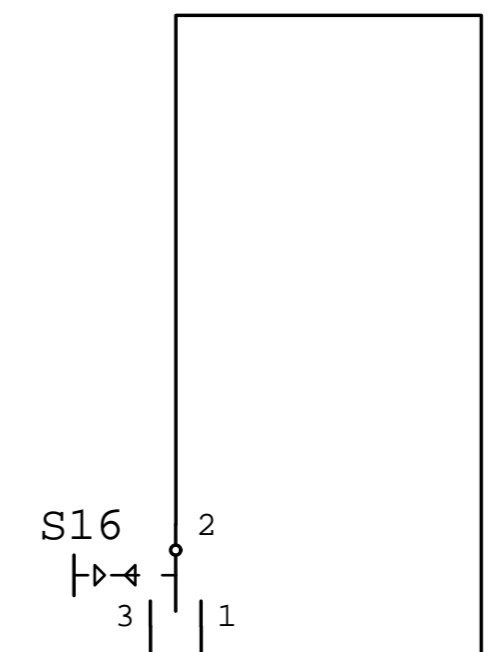

REACH
SPEED
LIMIT
SWITCH

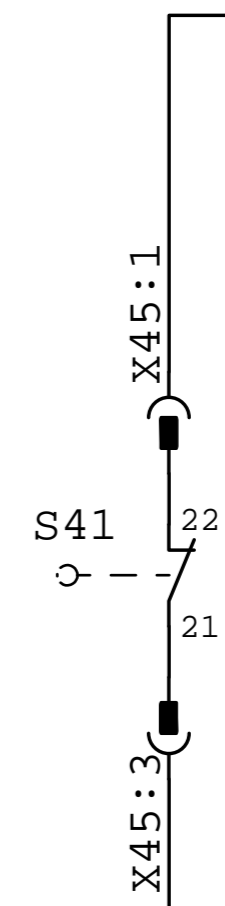

LIFT PRESSURE SWITCH

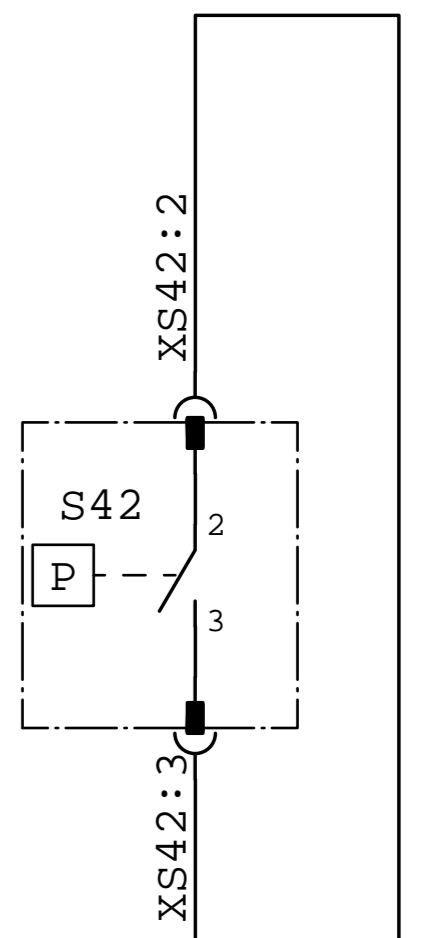

XA4D: 13
XA4D: 3
XA4D: 2 LOWER 0,5V - 2,5V - 4,5V LIFT
XA4D: 1
2,5V 0V (I10) 5V
SICOS/DISPLAY-UNIT

XA4D: 14
XA4D: 6
XA4D: 5 REACH OUT 0,5V - 2,5V - 4,5V REACH IN
XA4D: 4
(I11)

XA4D: 15
XA4D: 9
XA4D: 8 TILT DOWN 0,5V - 2,5V - 4,5V TILT UP
XA4D: 7
(I12)

XA4D: 16
XA4D: 12
XA4D: 11 SHIFT LEFT 0,5V - 2,5V - 4,5V SHIFT RIGHT
XA4D: 10
(I13)

XA4C: 8
XA4C: 9
XA4C: 18
(I14) (I15) 48V

XA5A: 10
XA5A: 38
XA5A: 11
XA5A: 25
(DI1) 48V (DI2) 48V
MHYRIO/VALVECONTROLLER

A4

A5



CIRCUIT DIAGRAM TS841200

NR14-25K, KC, KE, KH, KN
HYDRAULIC CONTROL CIRCUIT 1

7 / 23 REV

3-6777

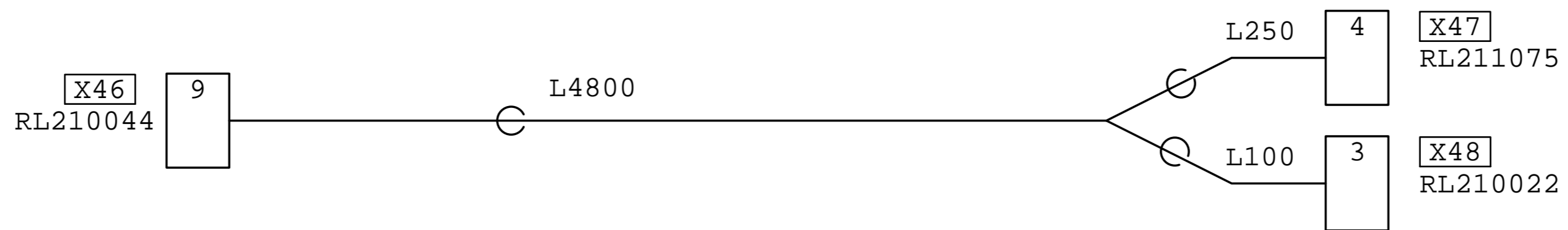

CIRCUIT DIAGRAM TS841200

NR14-25K, KC, KE, KH, KN
WIRE HARNESS W9: RL450684

18 / 23 REV

3-6777

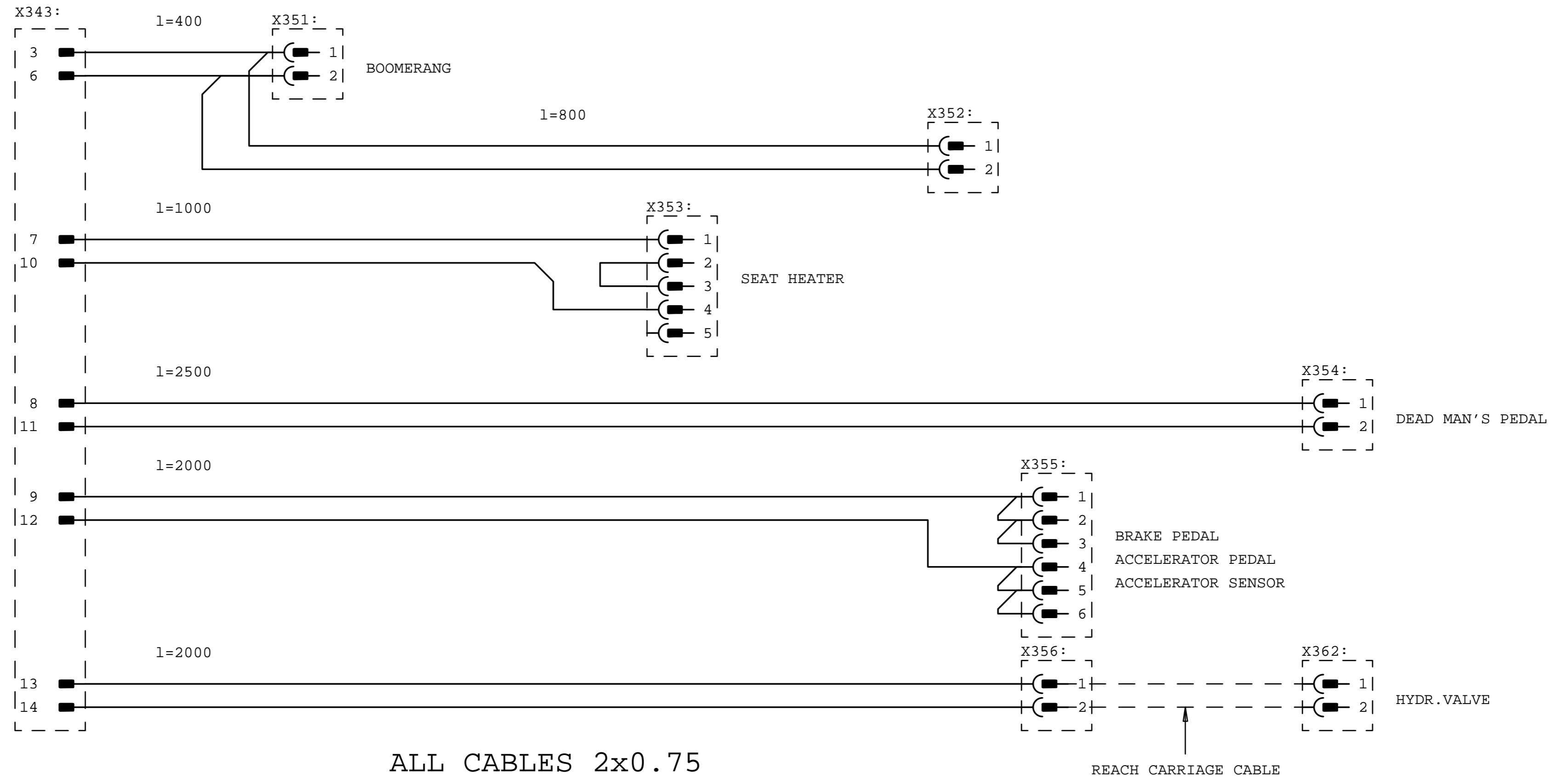

5. Driving instructions

Daily checks before operation

Carry out the daily maintenance check before using the truck. Neglecting daily maintenance may decrease the safety and reliability of the truck. Notify the site supervision immediately if you notice an error or deficiency during the check.

- Check the truck externally to see that there are no oil leaks.
- Check all wheels for damage or wear.
- Check the battery fluid in each battery cell. Top up with battery water if needed. The fluid surface should be about 15 mm above the plates (this does not apply to maintenance-free batteries).
- Check the gearbox for leaks. Also check the hydraulic pipes, hoses, and connectors. No leaks or damage should be found.
- Switch on the power and test the operation of the lifting hydraulics by raising and lowering the forks.
- Check the operation of the accelerator and steering by driving slowly forward and backward.
- Also check the operation of the other electrical functions.
- Check that the batteries are charged and locked in place.
- Check the operation of the horn.
- Check that the safety pedal works and that the brake pedal and parking brake function properly.
- Check that the emergency stop operates properly.
- Check the fastenings of the lifting chain.

Before you start:

- Make sure that the daily maintenance has been carried out.
- Switch on the power.
- Release the parking brake.
- Grip the steering wheel knob with your left hand and use the valve levers with your right hand.
- Take a position where your left foot is on the safety pedal and your right foot is on the accelerator.

Driving

- Press the safety pedal down to move the truck.
- Press the accelerator pedal lightly.
- To brake, press the brake pedal.
- Steer the truck smoothly because abrupt movements may cause a dangerous situation, especially when driving at high speeds.

Electronic steering system

The truck is equipped with a fully electronic steering system. The steering wheel movement is transmitted without a mechanical connection to the steering motor that controls the drive wheel.

The system consists of three main components:

1. Tachometer located in the steering wheel
2. Control unit located in the motor compartment
3. Steering motor, which is also in the motor compartment.

The control unit processes the signal coming from the tachometer and directs the steering motor to turn the drive wheel in the desired direction. In addition, the control unit constantly monitors the status of the system and reacts immediately if there are any problems.

Notice that when the drive wheel reaches its maximum position ($\pm 90^\circ$), the steering wheel can still turn without a mechanical stop.

NOTE: Do not turn the steering wheel unnecessarily when the truck is not moving.

Safety

When the power is turned on from the key switch, the system performs a self-diagnostic test. The test lasts for less than a second, after which the truck is ready for operation.

When the power is on, the control unit sends continuous diagnostic check signals throughout the system. This signal can be heard as a tapping noise emitting from the truck. In case of a system malfunction, the control unit will react immediately to the situation by switching off the drive operation and switching on the magnetic brake, and the truck will stop.

CLICK HERE TO **DOWNLOAD** THE COMPLETE MANUAL

- Thank you very much for reading the preview of the manual.
- You can download the complete manual from: www.heydownloads.com by clicking the link below



- Please note: If there is no response to CLICKING the link, please download this PDF first and then click on it.

CLICK HERE TO **DOWNLOAD** THE COMPLETE MANUAL