



BI015807  
October 2014



# Operation and Maintenance Manual

---

6090FS  
Hydraulic Shovel

No. DHS90006

---



CLICK HERE TO **DOWNLOAD** THE COMPLETE MANUAL

- Thank you very much for reading the preview of the manual.
- You can download the complete manual from: [www.heydownloads.com](http://www.heydownloads.com) by clicking the link below



- Please note: If there is no response to CLICKING the link, please download this PDF first and then click on it.

CLICK HERE TO **DOWNLOAD** THE COMPLETE MANUAL

# BETRIEBSANLEITUNG RH 400

## Table of contents

HYDRAULIC SYSTEM _____	4-9
Repair _____	4-9
PRESSURE ACCUMULATORS - SAFETY INSTRUCTIONS _____	4-10
WELDING OPERATIONS - SAFETY INSTRUCTIONS _____	4-11
NOTES _____	4-13
<b>5 ANNEX _____</b>	<b>5-1</b>
TROUBLESHOOTING _____	5-3
Instructions on troubleshooting _____	5-3
Layout of the fault table _____	5-3
Possible causes _____	5-3
Measures _____	5-3
Section _____	5-3
FAULT TABLES _____	5-4
Combustion engine - Fault table _____	5-4
Working hydraulics – Fault table _____	5-5
Track drive – Fault table _____	5-6
Slewing mechanism – Fault table _____	5-7
Central lubricating system – Fault table _____	5-8
HYDRAULIC CIRCUIT DIAGRAM _____	5-10
TIGHTENING TORQUES AND ANGLES – TABLE _____	5-11
ABBREVIATIONS _____	5-13
TECHNICAL DATA _____	5-15
<b>6 INDEX _____</b>	<b>6-1</b>

Avoid any operation that might be a risk to machine stability.

Never travel across slopes; always keep the working equipment and the load close to the ground, especially when travelling downhill.

On sloping terrain always adapt your travelling speed to the prevailing ground conditions.

Before leaving the driver's seat always secure the machine against inadvertent movement and unauthorized use. Shut off the engines.

## **Special work in conjunction with utilization of the machine and maintenance and repairs as well as troubleshooting during work; disposal of parts and consumables**

Observe the adjusting, maintenance and inspection activities and intervals set out in the operating instructions, including information on the replacement of parts and equipment. These activities may be executed by skilled personnel only.

Brief operating personnel before beginning special operations and maintenance work, and appoint a person to supervise the activities.

In any work concerning the operation, conversion or adjustment of the machine and its safety-oriented devices or any work related to maintenance, inspection and repair, always observe the start-up and shut-down procedures set out in the operating instructions and the information on maintenance work.

Ensure that the maintenance area is adequately secured.

If the machine is completely shut down for maintenance and repair work, it must be secured against inadvertent starting by:

- removing the ignition key and
- attaching a warning sign.

Carry out maintenance and repair work only if the machine is positioned on stable and level ground and has been secured against inadvertent movements.

To avoid the risk of accidents, individual parts and large assemblies being moved for replacement purposes should be carefully attached to lifting tackle and secured. Use only suitable and technically perfect lifting gear and suspension systems with adequate lifting capacity. Never work or stand under suspended loads.

The fastening of loads and the instructing of crane operators should be entrusted to experienced persons only. The marshaller giving the instructions must be within sight or sound of the operator.

For carrying out overhead assembly work always use specially designed or otherwise safety-oriented ladders and working platforms. Never use machine parts as a climbing aid

## FIRE AND EXPLOSION HAZARD

2796685

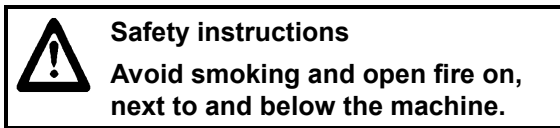

Combustible and easily flammable substances or liquids increase the fire and explosion hazard.

Do not store such substances on the excavator.

Clean the excavator thoroughly, if possible, with a steam jet (rubber parts and electric components with compressed air - refer to information label), when, for example, oil, grease, fuel or cleaner was spilled.

Such substances may spontaneously ignite if they get into the vicinity of hot units or objects such as turbo superchargers.

Even battery gases can ignite in open flames or fire.

Avoid parking the excavator in places where

- combustible substances such as coal dust or tar are present,
- open or smouldering fire may occur.

Remove the excavator from such an area where combustible or easily flammable liquids have spilled from the excavator onto the ground.

Flying sparks may cause fire on the ground that can spread to the excavator.

# OPERATING INSTRUCTIONS RH 400

## Operation

### Cab interior lamp

The interior lamp in the driver's cab and the amenity is switched on and off with the switch (2, Fig. 2-13:).

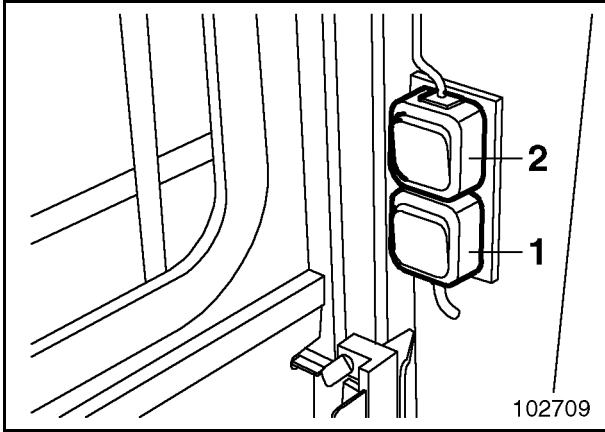

Fig. 2-13:

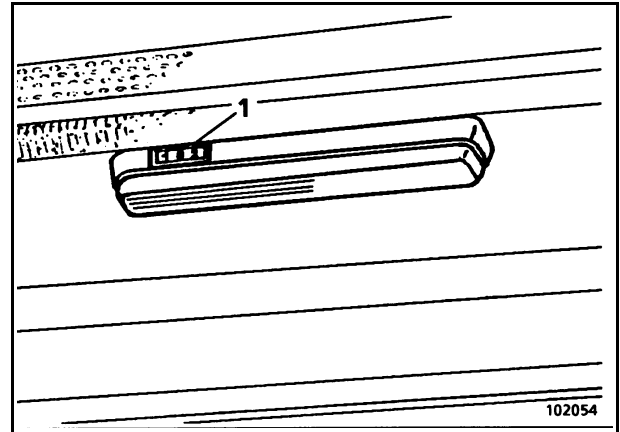

Fig. 2-15:

The interior lamp is switched on and off with switch (1, Fig. 2-15:).

Switch position 0 - lamp off

1 - lamp on

2 - not connected

The interior lamp can be used even if the electrical system is switched off.

Therefore, switch off the interior lamp when leaving the machine. The batteries may be discharged if the interior lamp is left on for prolonged periods.

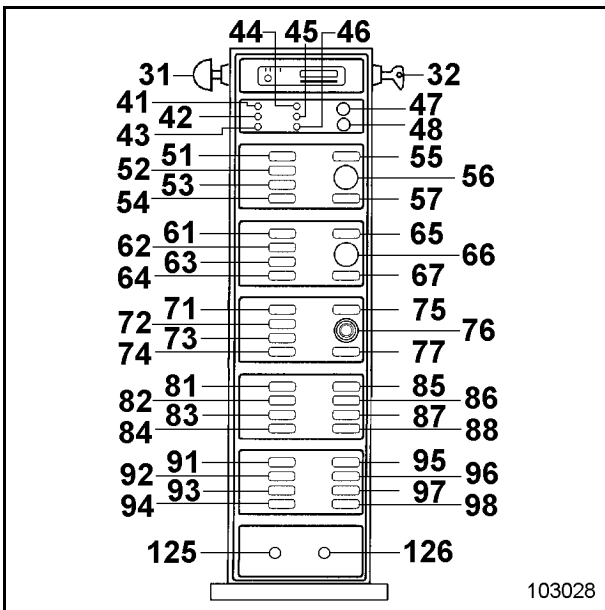

Fig. 2-14:

The interior lamp in the driver's cab can be switched on and off separately from the amenity with the switch (96, Fig. 2-14:).

Fig. 2-26

No.	Element	Function	Symbol
31	<b>Botton Emergency OFF</b>	Shuts off the whole electrical system	
32	<b>Key-switch</b>	Switches the electrical system on and off	
33	<b>Buzzer</b>	<p><b>Gives an acoustic warning signal if a fault is reported</b></p> <ul style="list-style-type: none"> <li>▪ Fault in engine system (engine 1 and / or 2; left and / or right)</li> <li>▪ Coolant level (engine 1 and / or 2; left and / or right) too low</li> <li>▪ Engine oil pressure (engine 1 and / or 2; left and / or right) too low</li> <li>▪ Engine oil temperature (engine 1 and / or 2; left and / or right) too high</li> <li>▪ Hydraulic oil level too low</li> <li>▪ Distributor gearbox temperature (1 and / or 2; left and / or right) too high</li> <li>▪ Slewing pump temperature (1, 2 and / or 3; left and / or right) too high</li> <li>▪ Slewing gearbox temperature (1, 2, 3, 4, 5 and / or 6) too high</li> <li>▪ Fault in lubricating system</li> </ul> <p> <b>Lower the equipment to the ground and shut off engine immediately if the buzzer (33) sounds and the BCS indicates a fault. The buzzer (33) continues to sound until the fault has been retified.</b></p>	



Fig. 2-36:

No.	Element	Function	Symbol
121	Radio (optional)		
123	Lever Locking the left console	Lever vertical – console locked. Pushed forward – locking released. Console can be displaced.	
124	Lever Locking the right console	Lever vertical – console locked. Pushed forward – locking released. Console can be displaced.	
125	Warning lamp Oil interval prolonging (left engine 1, optional)	lamp is lit up, when one oil pump is running flashes or pulsates, when both oil pump are running	
126	Warning lamp Oil interval prolonging (right engine 2, optional)	lamp is lit up, when one oil pump is running flashes or pulsates, when both oil pump are running	
127	Antenna (optional)		

## Switching the electrical system on and off

The electrical system is switched on with key-switch (32, Fig. 2-53:).

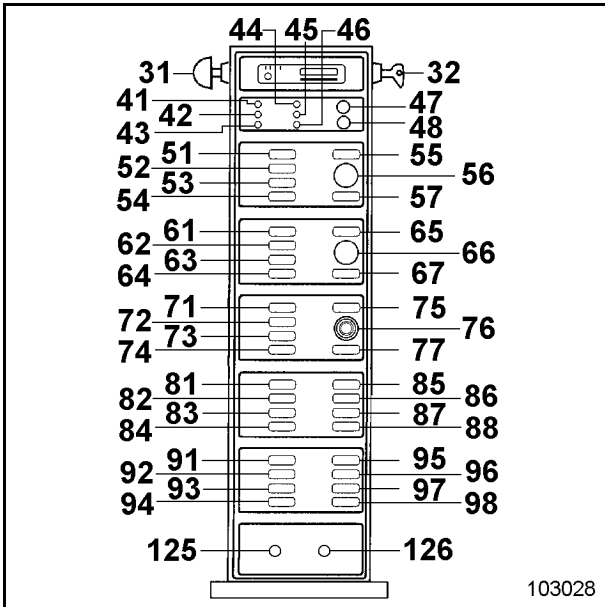

Fig. 2-53:

- ➔ Activate emergency OFF pushbutton (31, Fig. 2-53:)

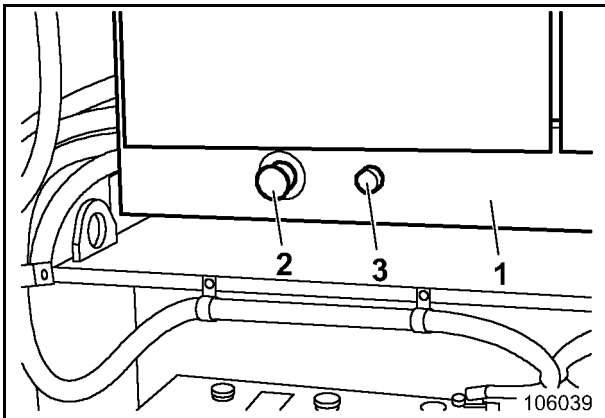

Fig. 2-54:

- ➔ Activate emergency OFF pushbutton (2, Fig. 2-54:)

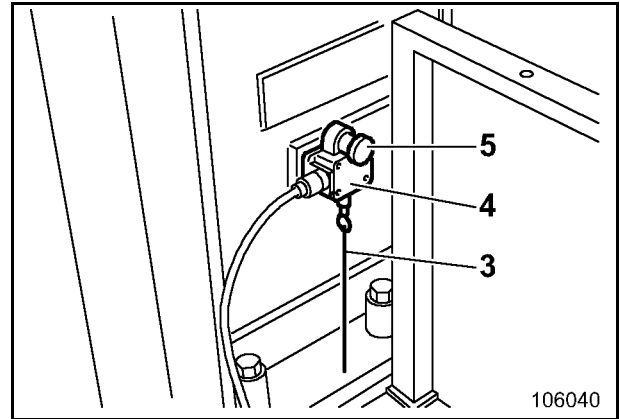

Fig. 2-55:

- ➔ Activate emergency OFF pushbutton (4, Fig. 2-55:)

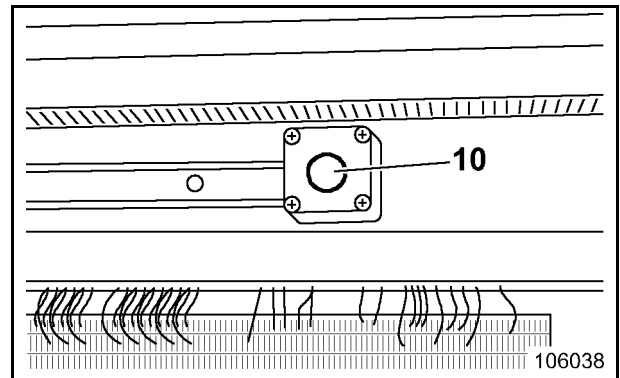

Fig. 2-56:

- ➔ Switch on battery main switch (120, Fig. 2-56:)
- ➔ Insert key into key-switch (32, Fig. 2-52:) and turn to the right.

## Locking the superstructure

The excavator is equipped with six superstructure holding brakes. The superstructure holding brakes are used to block the superstructure and the undercarriage.

The superstructure holding brakes are parking brakes.

- Switch the parking brakes on
- when the excavator is parked
- when travelling over longer distances
- to activate the parking brakes, press switch (82, Fig. 2-77:).

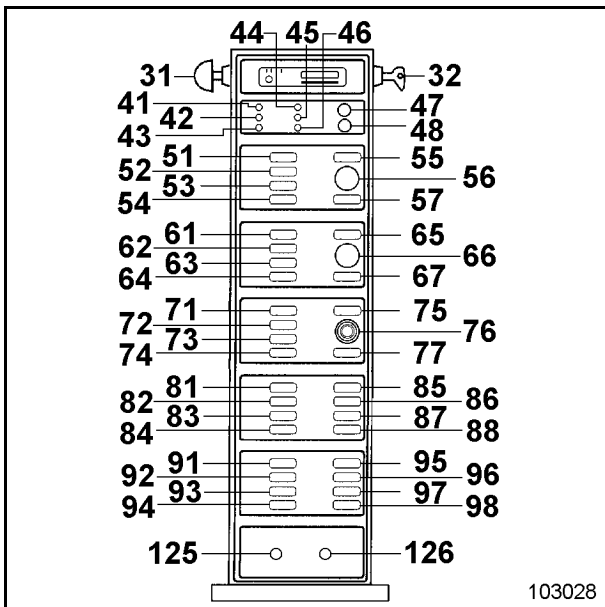

Fig. 2-77:

## Track parking brake

The excavator is equipped with four track brakes integrated in the track drives.

The track brakes are parking brakes which relieve the hydro-static travel drives during working operation and which protect the excavator against rolling forwards and backwards.

The brakes are controlled by means of the travel pedals (112 and 113, Fig. 2-78:). In neutral position of the pedals, the brakes are applied and the excavator is braked. During travelling, the brakes are released.

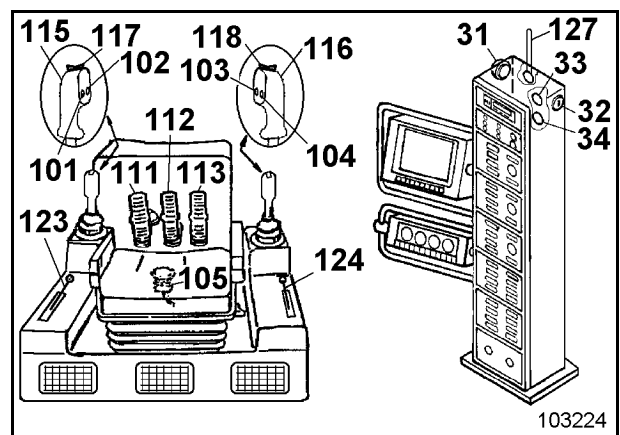

Fig. 2-78:

The track brakes can also be activated with switch (72, Fig. 2-77:).

Depending on switch position, the brakes are permanently engaged or

are automatically applied after ca. 8 sec. each time the excavator stops.

With this switch position, the brakes are released as soon as the "Travel" function is activated.

## CORROSION PROTECTION FOR PINS AND BEARINGS (BUSHINGS AND HUBS)

2281259

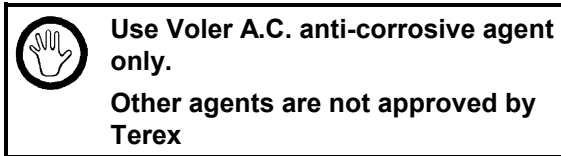

All pins and bearings (bushings and hubs) of the working equipment or in equipment components must be treated **Voler A.C.** anti-corrosive agent before fitting.

### Voler A.C.:

- permits easy fitting and dismantling
- protects against rust, oxidation and similar wear
- prevents seizing and fretting corrosion in non-moving parts of bearings.

This is achieved by aluminium and copper particles forming a protective layer on the metal. This layer removes surface irregularities and does not sweat, seize or harden.

### Part nos. for Voler A.C.

SN 0 271 554 - 0,5 l spray can (CSC free)

SN 1 438 473 - 0,5 kg tin

SN 1 438 219 - 4,5 kg bucket

Available from Terex–Germany Spare-Parts Service

### Application of Voler A.C.

- Clean off grease, oil, dirt and corrosion protection agents from pins and bearings using white spirit or diesel fuel.  
Rust patches must be thoroughly removed, if any.  
All parts must present a dry, bright metal surface.
- Apply a thin layer of Voler A.C. on pins and all bearings using a brush or a spray can. Pin shafts and bearings must be completely covered by the protective layer.  
If the protective layer of a pin already treated with Voler A.C. is damaged, these areas must be touched up before fitting the part.
- Fitting and securing of pins  
If the pin is too heavy to be fitted manually, apply Voler A.C. at first only on abt. a quarter of the pin's length  
Then position pin by means of a lifting gear-ready for fitting.  
Apply Voler A.C. on the remaining length of pin shaft, fit pin and secure.



### Handling batteries

Battery Posts, terminals and related accessories contain lead and lead compounds, chemicals known to cause cancer and reproductive harm. Wash hands after handling

Batteries give off explosive gases.

Never handle batteries close to naked flames and unshielded light sources, never smoke.

Battery acid is toxic and corrosive.

Avoid any contact with the skin, mouth, eyes and clothing. Avoid spilling battery acid or inhaling the vapours.

Wear gloves, firm protective clothing and goggles when handling batteries.

If the skin is splashed with acid, rinse thoroughly with running water and consult a doctor.

If the eyes are splashed with acid, rinse thoroughly with running water and consult a doctor immediately.

Never set tools down on the battery. They may induce a short circuit, causing irreparable damage to the battery and injuring persons.

Never wear metal necklaces, bracelets or watch-straps when working on the battery. The metal parts may induce a short-circuit resulting in burns.

Dispose of used batteries separately from other waste in the interests of environmental protection.

### Before working on the electrical system

Before performing work on the electrical system where tools, spare parts, etc. can come into contact with electrical conductors or contacts, the battery must be disconnected.

Disconnect first the negative and then the positive terminal.

After the work:

Reconnect first the positive and then the negative terminal.

CLICK HERE TO **DOWNLOAD** THE COMPLETE MANUAL

- Thank you very much for reading the preview of the manual.
- You can download the complete manual from: [www.heydownloads.com](http://www.heydownloads.com) by clicking the link below



- Please note: If there is no response to CLICKING the link, please download this PDF first and then click on it.

CLICK HERE TO **DOWNLOAD** THE COMPLETE MANUAL

## Plan T

(Every 10 OH or every working shift

(whichever comes first)

Every 60 OH or every working shift

(whichever comes first)

Page 1 von 2

Location	Servicing work	Quantity/ No.	Plan T	Plan W
<b>Engine</b>	Check oil level	2	●	●
Engine oil reservoir	Check oil level	2	●	●
<b>Cooling system</b>				
Cooling fluid level	Check	2	●	●
Radiator	Check / clean	2	●	●
<b>Fuel system</b>				
Fuel filter	Drain off water	2 x 2	●	●
Cooler	Check / clean	2		●
<b>Air-intake system</b>				
Intake and clean-air lines	Check BCS - indication	1		●
	Check for tightness and leaks			●
<b>Electrical system</b>				
Lighting	Check operation		●	●
Switchgear cabinet				
- Breather filter				
- Dust trap	Remove dust	1		●
- EMERGENCY OFF button	Check function	3		●
<b>Monitoring, warning and control elements</b>				
Check function of monitoring, warning and control elements			●	●
BCS	Check function	1	●	●
<b>Hydraulic system</b>				
Check function of working and travelling movement			●	●
Inspect visually for leaks				●
Hydraulic oil reservoir	Check oil level	1	●	●
Oil cooler	Check / clean	2		●
Fan wheel	Check condition	2	●	●
<b>Pump transfer gearbox</b>				
Check oil level		2		●
Oil filter (tell-tale)	Check	2 x 1		●
<b>Slewing gearbox</b>				
Expansion reservoir	Check oil level	6	●	●
<b>Travel gearbox</b>				
Check for leaks		2	●	●

## Lubricating chart – Grease / Loading bucket (legend)

No.	Greasing point	Number	Lubricant properties	Grease every ... operating hours
1	Central lubricating system – grease container	1	<b>V</b> <sup>14</sup>	10
2	Slewing gear throat	6 x 2		5000
4	Ramp-type ladder (optional)		<b>V</b> <sup>14</sup>	
	- Deflecting roller	3		1000
	- Locking bolt	1	<b>I</b> <sup>14</sup>	1000
5	On-board crane		<b>V</b> <sup>14</sup>	250
	- Bearing	4		250
	- Joint (column / boom)	2		250
	- Cylinder bearing	5		250
	- Slewing ring	1	<b>Graphitspray</b>	250
6	Monitoring, warning and control elements		<b>II</b> <sup>14</sup>	
	- Joystick	2 x 4 <sup>15</sup>		1000
	- Pedal	3 x 2 <sup>15</sup>		1000

All other greasing points are supplied with grease by the central lubricating system.

## Filling quantities - Grease

Greasing point	Lubricant properties	Filling quant. in kg
Central lubricating system – grease container	<b>V</b> <sup>14</sup>	500
Internal gearing – Roller-bearing slewing ring		600
Slewing gear throat		2 x 0.5 (6 x)
Idler		2 x 36
Track rollers		14 x 45
Support rollers		4 x 15

<sup>14</sup> cf. "LUBRICANTS" section

<sup>15</sup> apply a thin layer of hydraulic oil

## Checking the engine oil level / Topping up

The engine oil pressure and oil temperature are constantly monitored by the BCS (Fig. 3-9:) when the machine is in operation.

The actual pressure and temperature of the engine oil can be displayed on the screen (Fig. 3-9:).

The BCS warns the operator if the engine oil pressure is too low and the oil temperature too high.

- Draw out dipstick a second time. The oil level should now lie between the marks (arrows, Fig. 3-11:).
- If the oil level is at the "min" mark or below, filled in from the service station (Fig. 3-12:) through
  - express coupling (8) for the lefthand engine
  - express coupling (9) for the righthand engine
 (see chapter "Changing the engine oil")

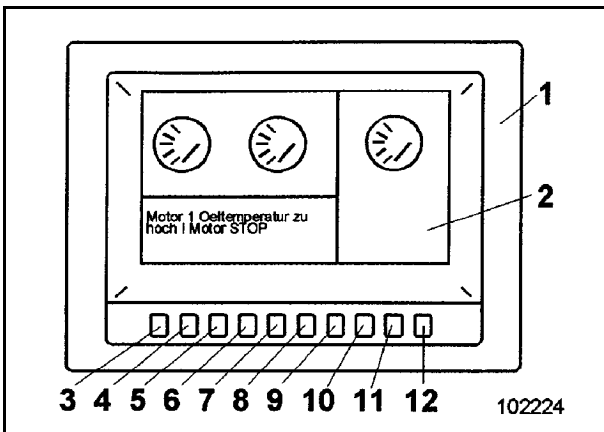

Fig. 3-9:

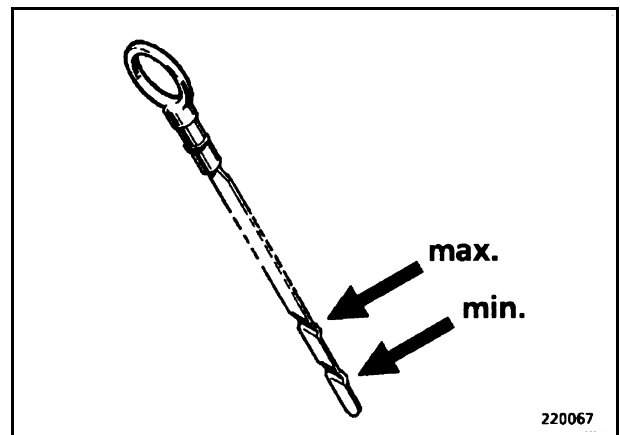

Fig. 3-11:

Engine oil can also be filled in through filler tube (2, Fig. 3-12:).

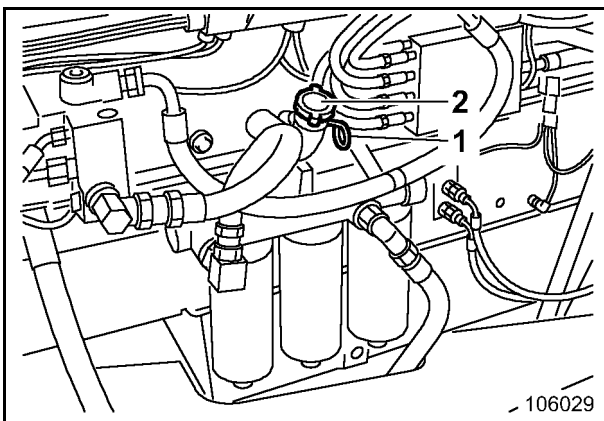

Fig. 3-10:

- Park the machine on a horizontal surface and secure against inadvertent movements.
- Shut off engines.
- Draw out oil dipstick (1, Fig. 3-10:).
- Wipe oil off the dipstick with a clean, lintfree cleaning rag and re-insert.

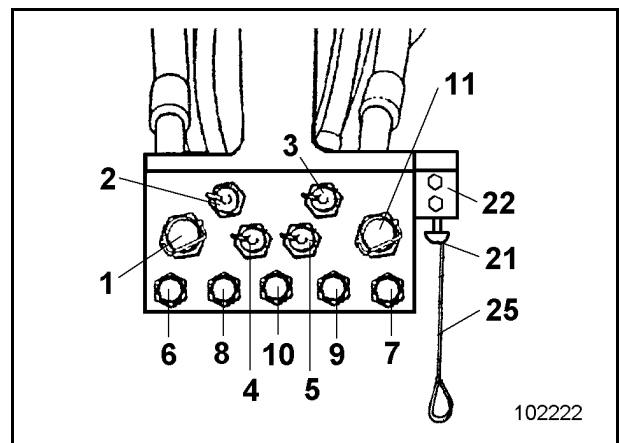

Fig. 3-12:

# OPERATING INSTRUCTIONS RH 400

## Inspection and servicing

### Cooling-liquid level

An insufficient cooling-liquid level is displayed on the BCS screen (Fig. 3-29:).

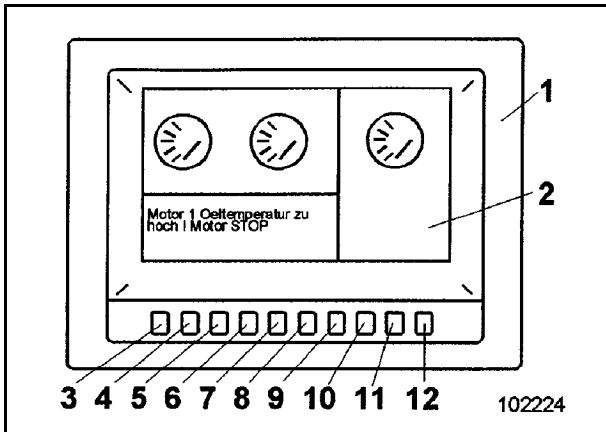

Fig. 3-29:

The cooling liquid level is indicated on the filling indicator (4, Fig. 3-30:)

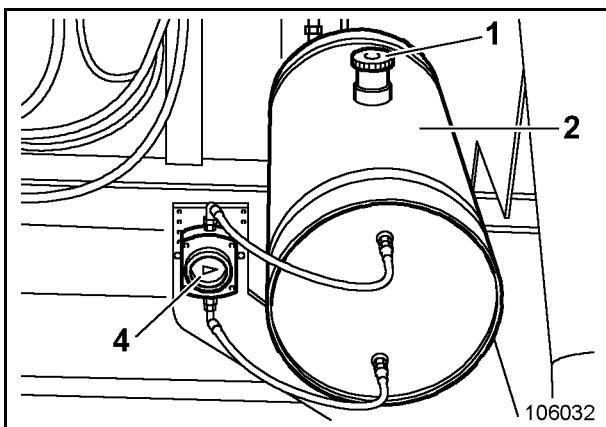

Fig. 3-30:

The cooling-liquid level should reach up to the lower edge of the filler tube. Top up with cooling liquid, if required.

The radiator caps (1, Fig. 3-30:) are accessible from above.



**Risk of scalding from hot cooling liquid. Open radiator cap cautiously.**

- Turn radiator cap (1) back to the first notch.
- When the pressure has been released turn cap into the "open" position and remove.

## Venting the fuel system

The fuel tanks are vented with breather valves (3, Fig. 3-47:).

Clean breather valves regularly.

- Remove breather valve, flush with paraffin oil and blow clean with compressed air.

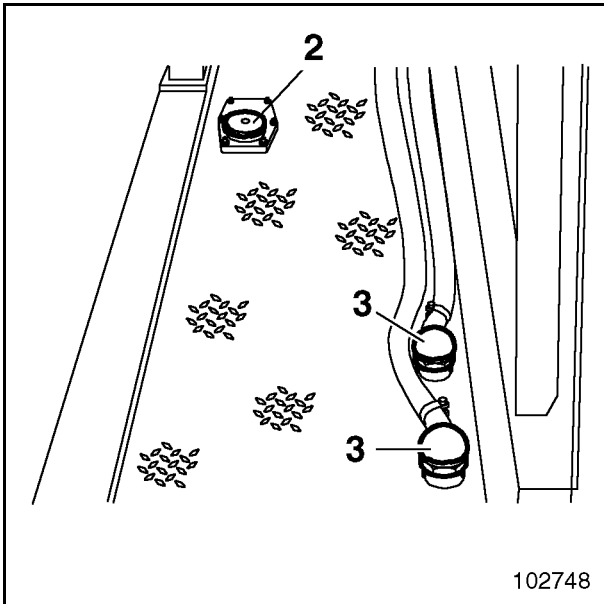

Fig. 3-47:

## Cleaning the fuel tanks



**Explosion hazard.**

**Read and observe the "Inspection and servicing. Safety instructions" chapter.**

Do not use white spirit, paraffin oil or other solvents.

For flushing and cleaning use diesel fuel.

Avoid skin contact.

Skin contact with diesel fuel may cause skin injury.

Wear firm working clothing.

Wear protective gloves or use a barrier cream.



**Fuel must be prevented from penetrating into the soil. Keep fuel for re-use or discard without polluting the environment.**

- Use up as much fuel as possible.
- Check how much fuel remains in the tank and place a collecting recipient of sufficient size under the drain plugs of the tanks.
- Loosen drain plug (5, Fig. 3-48:) at fuel the tank and drain off fuel.
- Flush tank with diesel fuel.
- Screw automatic drain plug backs (5) in place.

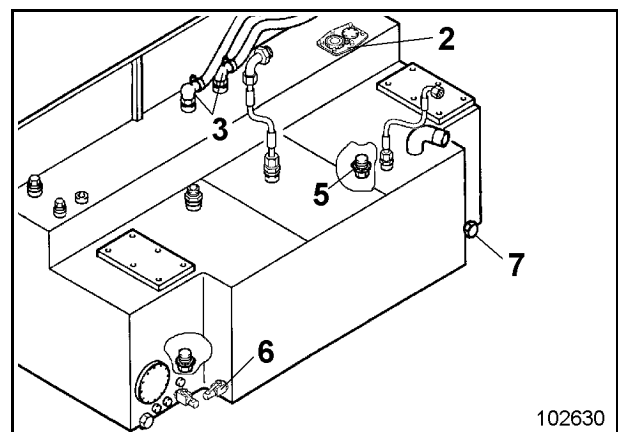
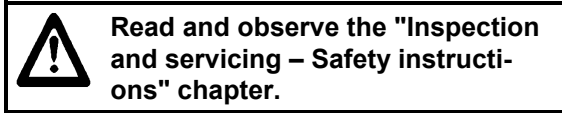

Fig. 3-48:

## Changing the hydraulic oil re- turn-flow (hydraulic oil reservoir)



Shut off the engines.

Risk of scalding caused by hot hydraulic oil.

The hydraulic oil reservoir itself may also be hot.

Avoid skin contact.

Skin contact with hydraulic oil may cause skin injury.

Wear protective gloves and firm working clothing.

Collect escaping hydraulic oil and discard without polluting the environment.

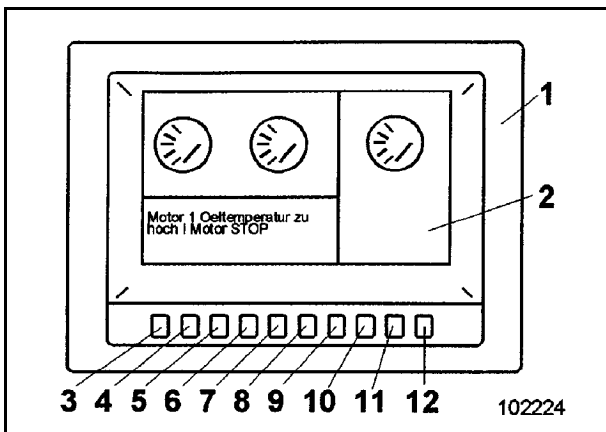

Fig. 3-66:

The return-flow filters must be replaced:

- when servicing works in accordance with the servicing plan are carried out;
  - when the BCS displays a warning on the screen (Fig. 3-66:). In this case, the filter elements (9, Fig. 3-67:) are heavily contaminated;
  - after repairs on the hydraulic system;
  - in case of damage.
- ➡ Remove cover (3) together with sealing ring (5) and retaining disk (7).
- ➡ Remove cap (8) and sealing ring (10).
- ➡ Withdraw filter element (9) and sealing ring (11) from basket (12).
- ➡ Insert a new filter element.

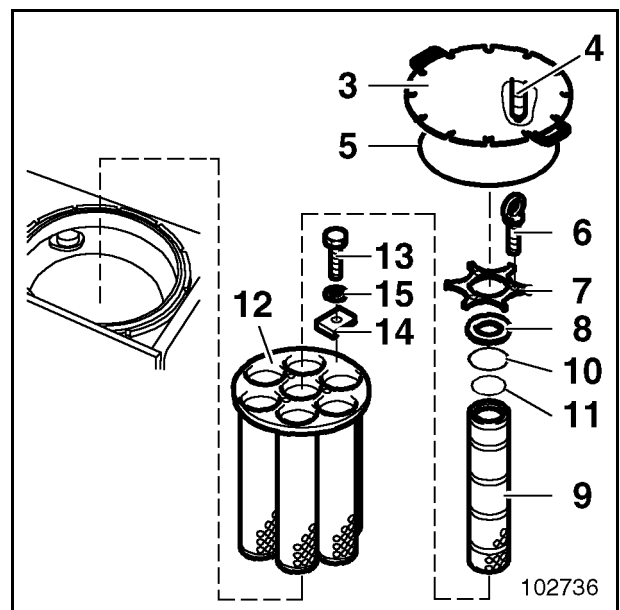

Fig. 3-67:

If a filter element (9) is damaged, remove basket (12) and check/clean.

## High-pressure filters for feeding circuits and slewing pumps

The excavator has one high-pressure filter (3, Fig. 3-82:) for each feeding circuit. The high-pressure filters are located above the distributor gearboxes.

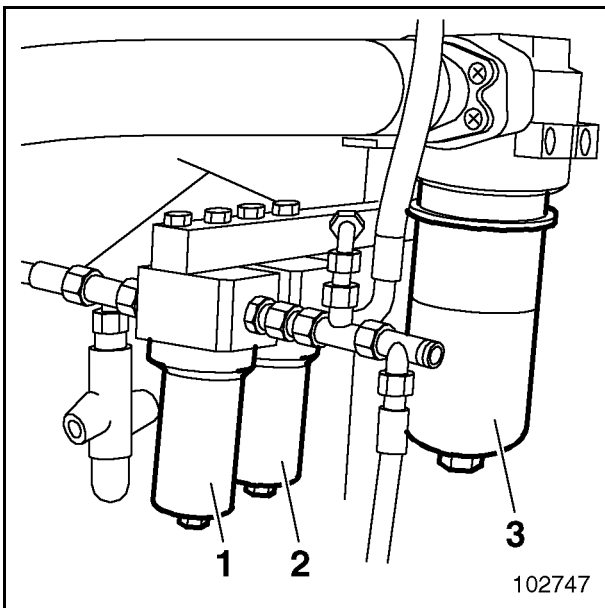

Fig. 3-82:

Shut off the engines.

Risk of scalding from hot hydraulic oil.

The filter housings may also be hot.

Avoid skin contact.

Skin contact with hydraulic oil may cause skin injury.

Wear protective gloves and firm protective clothing.

Collect escaping hydraulic oil and discard without polluting the environment.

## Checking/cleaning the filter element

- Unscrew drain plug (11, Fig. 3-83:) and drain the hydraulic oil from the filter housing (9).
- Remove filter housing (9).
- Withdraw filter element (15) from filter housing (9).
- Clean filter housing (9) and sealing faces at filter head with white spirit or paraffin oil.
- Insert new filter element into filter housing (9) and refit to filter head with a new, lightly oiled sealing ring (14).

Check the high-pressure filter for leaks after putting it into operation.

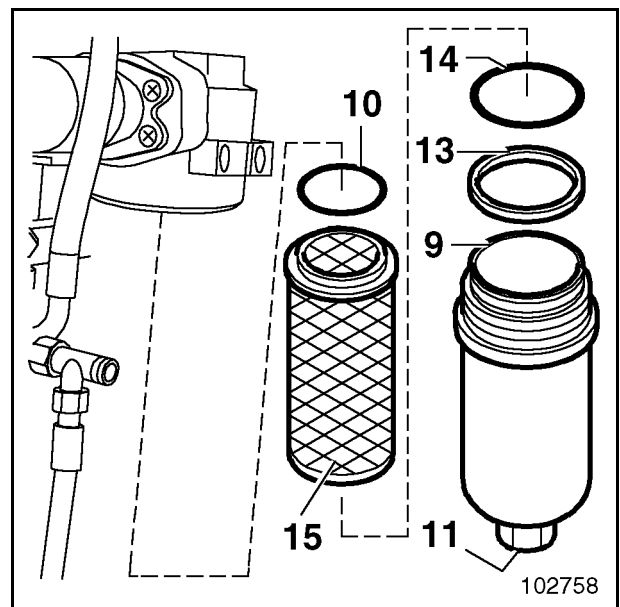

Fig. 3-83:

## Replacing the filter elements

- Detach the filter elements as described under "Checking the filter elements".
- Install new filter element (15, Fig. 3-83:) and re-assemble with a new, lightly oiled sealing ring (14).

Check the high-pressure filter for leaks after putting it into operation.

## Filling in oil

The gearbox oil is filled in with the service station (Fig. 3-101:) through

- express coupling (4) for the lefthand pump transfer gearbox
- express coupling (5) for the righthand pump transfer gearbox

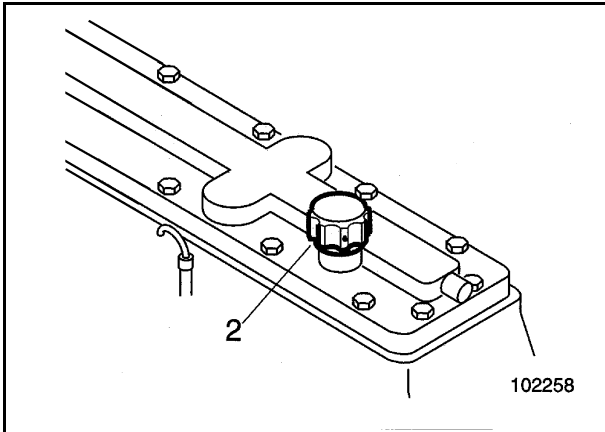

Fig. 3-101:

- ➔ Unscrew cap of express coupling and connect hose line of the service vehicle.

The hose line and its use are described in the "hose line for oil and cooling liquid change" section.

The oil level must reach the upper mark on dipstick (1, Fig. 3-102:).

- ➔ Remove hose after the oil has been filled in. The coupling closes automatically.
- ➔ Screw on protective cap.

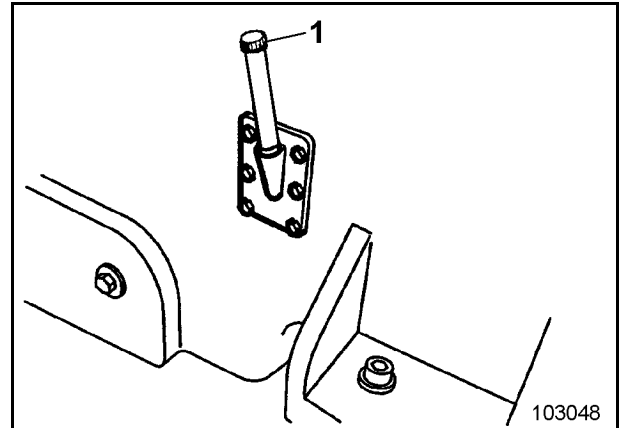

Fig. 3-102:

Oil can also be filled in through the bore of the breather valve (2, Fig. 3-103:)

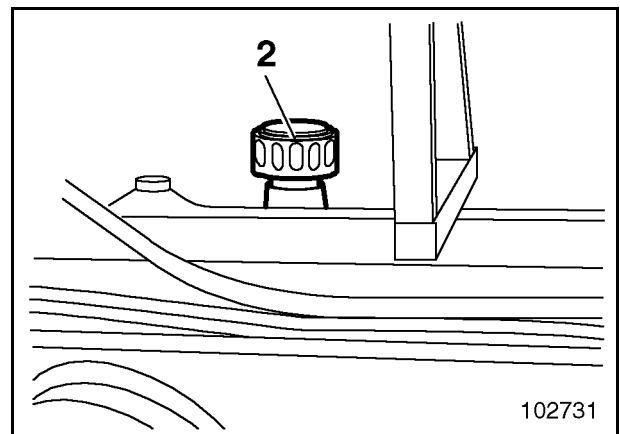

Fig. 3-103:

## Checking the gas charging pressure in the pressure accumulator

After commissioning (new installation or repair), the gas charging pressure in the pressure vessel must be checked at least once during the first week. If no pressure loss is detected, the second pressure test must be performed after ca. 3 months. If no pressure loss is detected in this test either, the testing interval can be fixed at once pressure test **each year**.

The above-mentioned pressure tests are required to ensure the functioning of the track tensioner. They are **no substitute** for the inspections as required by the "Pressure Vessel Regulations".

Before checking the gas charging pressure (nitrogen filling pressure) in the pressure accumulator, the track must first be slackened, i.e. the hydraulic part of the tensioning system must be depressurized. Cf. under "Function".

For measuring the precharge pressure in the pressure accumulator, observe the instructions set out in the booklet "Filling and testing device for pressure accumulators" annexed to this documentation.

Group	Inspections prior to commissioning		Regular inspections
	at the factory	at the place of use	
IV $p \geq 1 \text{ bar}$ $p \cdot x \geq 1000$	Preliminary inspection by an expert Prototype and pressure test certified by the manufacturer (type approval) or the expert	Acceptance inspection by an expert	Internal inspection: every 10 years for non-corrosive fluids; otherwise pressure testing every 5 years: every 10 years by an expert

## RAMP-TYPE LADDER

3659749

To allow the ramp-type ladder (Fig. 3-143:) to be lowered in an emergency, the ladder mechanism is equipped with a pressure accumulator (1, Fig. 3-144:).

The pressure accumulator (1) is located in the superstructure and is accessible from the ground.

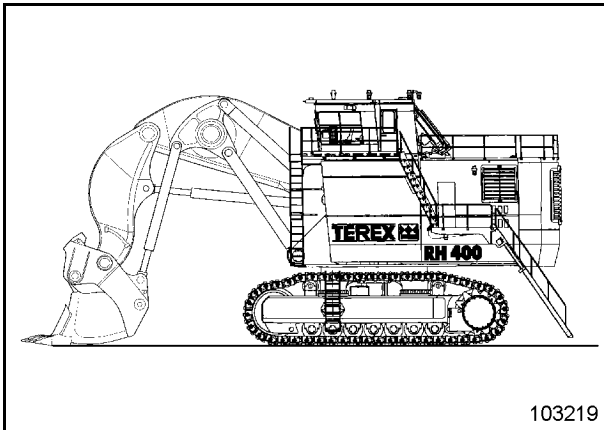

Fig. 3-143:

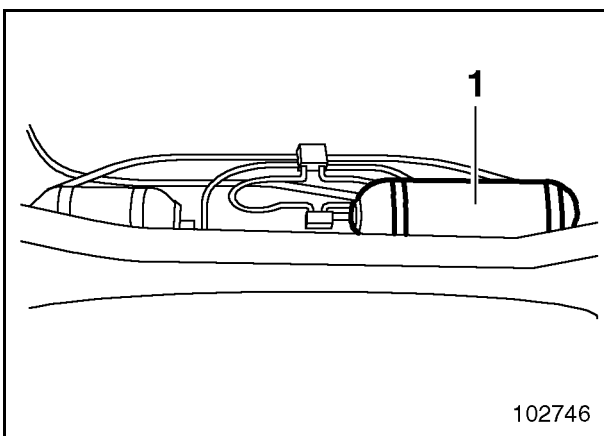

Fig. 3-144:

## Guide pulleys and locking bolt

Lubricate the bearings (1, Fig. 3-145:) of the guide pulleys at regular intervals and apply a few drops of oil to the locking bolt (2).

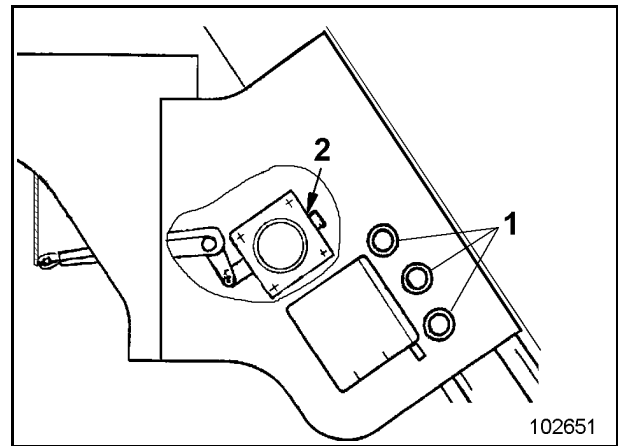

Fig. 3-145:







**Central lubricating system – Fault table**

Fault				Remedial action	
Grease pump not working, the BCS does not indicate a warning Automatic circuit breaker on				Check	P
Grease pump not working, pilot lamp lit				Adjust	E
Grease pump working, no grease delivered				Replace	W
Greasing pressure too high or too low				Top up	A
				Reduce	S
				Clean	R
				Vent	L
				1) Contact the Terex-Germany Service	
<b>Cause</b>				<b>Chapter ref.</b>	
•	•		Timer defective		P/W
•			Lines between timer and hydraulic motor defective		P/W
•	•		Hydraulikmotor defektive		P/W
•	•	•	Grease pump defective		P/W
		•	Grease sieve clogged		P/R
		•	Distributor defective		P/W
		•	Grease container empty		P/A
		•	Grease pump does not suck grease		P/L
		•	Leaky lines		P/L
		•	Non-return valve defective		P/W
		•	Pressure switch defective		E

CLICK HERE TO **DOWNLOAD** THE COMPLETE MANUAL

- Thank you very much for reading the preview of the manual.
- You can download the complete manual from: [www.heydownloads.com](http://www.heydownloads.com) by clicking the link below



- Please note: If there is no response to CLICKING the link, please download this PDF first and then click on it.

CLICK HERE TO **DOWNLOAD** THE COMPLETE MANUAL