



# Operation and Maintenance Manual

---

## **TH220B and TH330B Telehandlers**

---

S/N TBF00100 & After  
S/N TBG00100 & After

*Keep this manual with machine at all times.*

---



CLICK HERE TO **DOWNLOAD** THE COMPLETE MANUAL

- Thank you very much for reading the preview of the manual.
- You can download the complete manual from: [www.heydownloads.com](http://www.heydownloads.com) by clicking the link below



- Please note: If there is no response to CLICKING the link, please download this PDF first and then click on it.

CLICK HERE TO **DOWNLOAD** THE COMPLETE MANUAL

# Safety Section

## Safety Messages

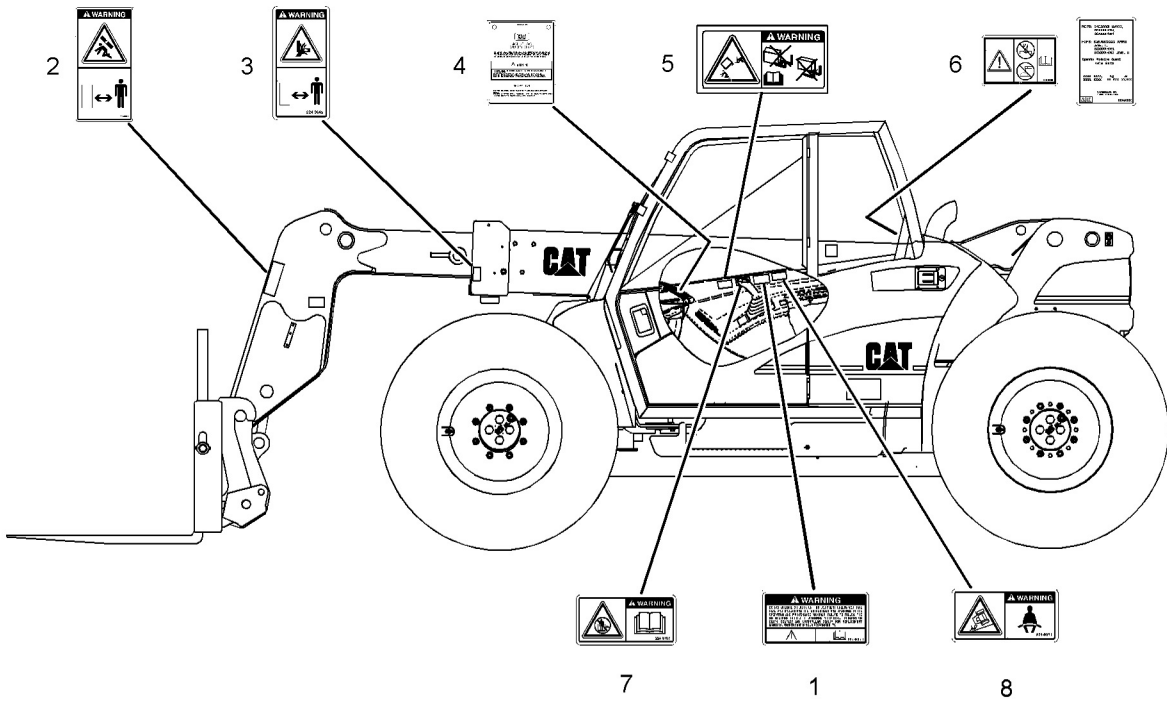

Illustration 2

g01106280

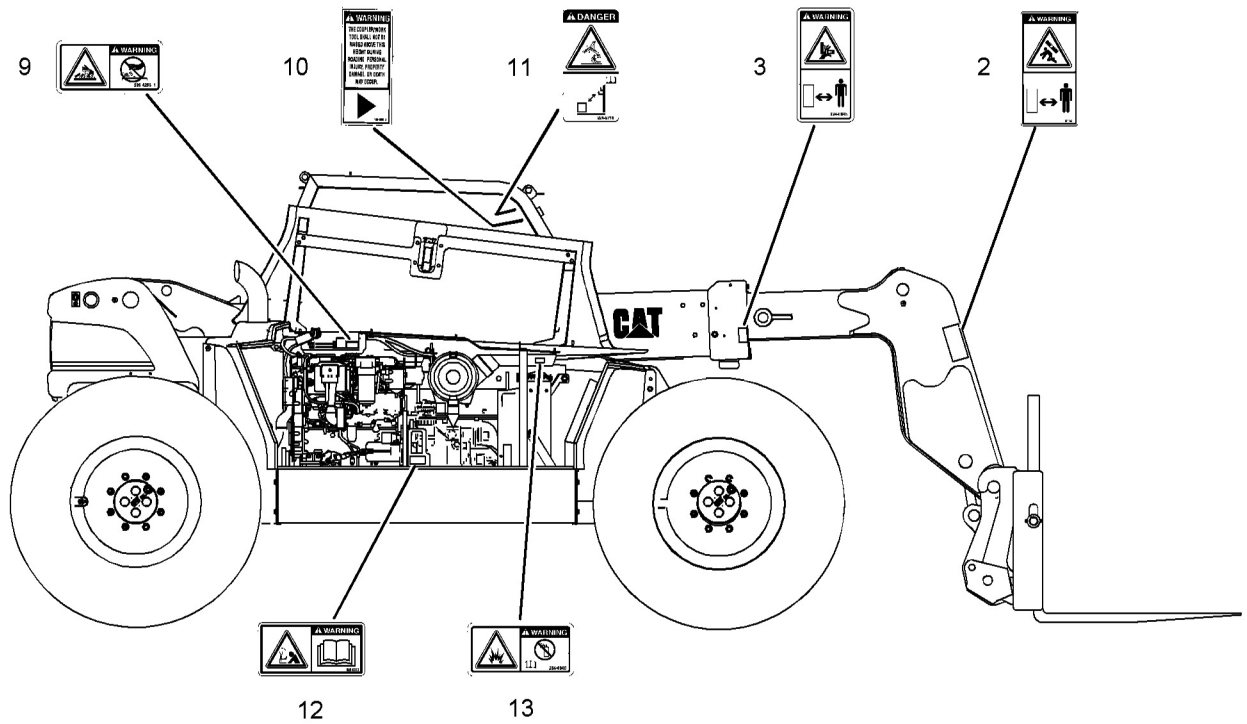
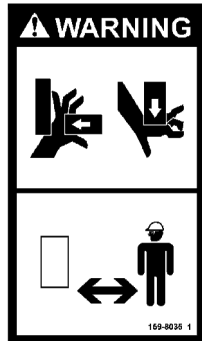

Illustration 3

g01106290

### Crushing Hazard (22)

This message is located on each side of the grapple bucket.



g00951565



No clearance for person in this area during operation. Severe injury or death from crushing could occur. Stay away from the work tool while it is in operation.

### Operation (23)

This message is located on the left hand cover at the rear of the broom.

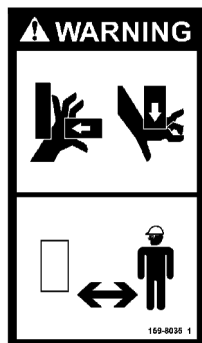

g00951565



Do not operate or work on this equipment unless you have read and understand the instructions and warnings in the Operation and Maintenance Manual. Failure to follow the instructions or heed the warnings could result in injury or death. Contact any Caterpillar dealer for replacement manuals. Proper care is your responsibility.

### Entanglement and Flying Objects (24)

This message is located on each side of the top cover for the broom.

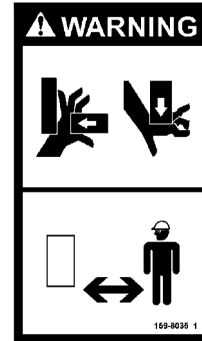

g00951565



Stay clear of this work tool during operation. Entanglement could result in personal injury or death. Flying objects from this work tool could result in personal injury or death.

### Trap Point (25)

This message is located on both sides of the hitch on the broom.

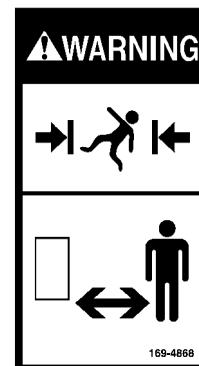

g00984061



No clearance for person in this area during operation. Severe injury or death from crushing could occur. Stay away from the work tool while it is in operation.

**Note:** Do not weld the ROPS in order to install the fire extinguisher. Also, do not drill holes in the ROPS in order to mount the fire extinguisher on the ROPS.

## Tire Information

Explosions of air inflated tires have resulted from heat-induced gas combustion inside the tires. Explosions can be caused by heat that is generated by welding, by heating rim components, by external fire, or by excessive use of brakes.

A tire explosion is much more violent than a blowout. The explosion can propel the tire, the rim components, and the axle components as far as 500 m (1500 ft) or more from the machine. Both the force of the explosion and the flying debris could cause property damage, personal injury, or death.

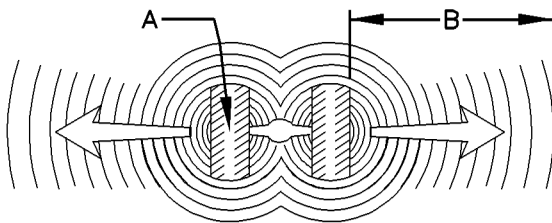

Illustration 24

g00847810

(A) At least 15 m (50 ft)  
(B) At least 500 m (1500 ft)

Do not approach a warm tire. Maintain a minimum distance, as shown. Stay outside the shaded area in Illustration 24.

To avoid overinflation, proper training in the usage of the equipment are necessary. A tire blowout or a rim failure can result from improper equipment or from misused equipment.

When you inflate a tire, stand behind the tread and use a self-attaching chuck.

Servicing tires and rims can be dangerous. Only trained personnel that use proper tools and proper procedures should perform this maintenance. If correct procedures are not used for servicing tires and rims, the assemblies could burst with explosive force. This explosive force could cause serious personal injury or death. Carefully obey the specific instructions from your tire dealer.

## Electrical Storm Injury Prevention

When lightning is striking in the vicinity of the machine, the operator should never attempt the following procedures:

- Mount the machine.
- Dismount the machine.

If you are in the operator's station during an electrical storm, stay in the operator's station. If you are on the ground during an electrical storm, stay away from the vicinity of the machine.

## Before Starting Engine

Operators must have had the proper training and operators must be capable in all aspects of machine operation. To comply with some local requirements, an operator must attain an operators license or a certificate.

You must be familiar with your machine in order to understand the machine's capabilities. Also, before you operate your machine you must become familiar with the job site. If necessary, walk around the area and take note of the following items.

- Check the area for clearance. Check for both vertical clearance and for horizontal clearance.
- Check for the presence of overhead obstructions.
- Check for electrical power lines. Keep the machine and the attachments away from electrical power lines at least 8 m (25 ft).
- Check for steam lines. Check for compressed air lines.
- Check for changes in the stability of the surface of the job site. Check trenches that have been backfilled. Check deteriorated roofs of basements and of tunnels.
- Check sewers and service ducts.

When a load is picked up or when the boom is extended, ensure that the surface on the job site offers even resistance for the tires. Also, when a load is picked up or when the boom is extended, ensure that the surface on the job site offers even penetration for the stabilizers.

Make sure that the load charts and the instruction plates are in place and that the load charts and the instructions can be read. Do not operate the machine until you understand the correct method of using the load charts.

On machines that are equipped with a cab, secure the door in the shut position. Secure the windows in either

## Certification

### European Union

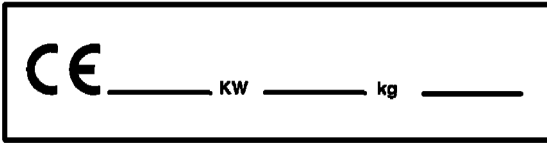

Illustration 34

g00853367

If the machine is equipped with the plate for the European Union, this plate will be attached to the PIN plate. Several pieces of information are stamped onto the CE plate. For quick reference, record this information in the spaces that are provided below.

- Engine Power (kW) \_\_\_\_\_
- Machine Weight (kg) \_\_\_\_\_
- Year of Manufacture \_\_\_\_\_

## Sound

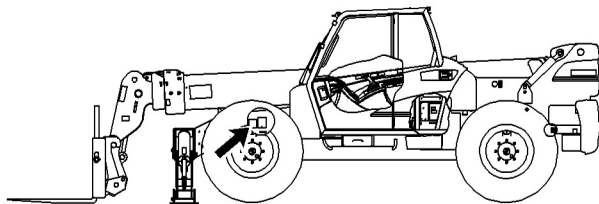

Illustration 35

g00937584

This message is located on the left side of the main frame.

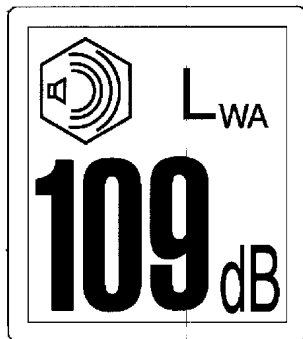

Illustration 36

g00933634

A typical example of this decal is shown. Your machine may have a different value.

If equipped, the certification decal is used to verify the environmental sound certification of the machine. The value that is listed on the decal indicates the

guaranteed sound power level. The guaranteed sound power level is measured at the time of manufacture. The guaranteed sound power level is measured according to the conditions that are specified in "2000/14/EC".

## ROPS/FOPS Decal

This safety sign is positioned behind the seat near the rear window.

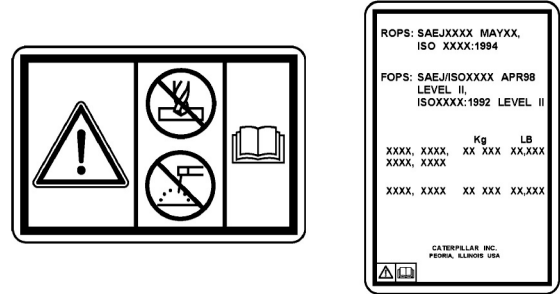

Illustration 37

g01211890



**Structural damage, an overturn, modification, alteration, or improper repair could impair this structure's protection capability thereby voiding this certification. Do not weld on or drill holes in the structure. This will void the certification. Consult a Caterpillar dealer to determine this structure's limitations without voiding its certification.**

This machine has been certified to the standards that are listed on the certification decal. The maximum mass of the machine, which includes the operator and the attachments without a payload, should not exceed the mass on the certification decal.

Refer to Operation and Maintenance Manual, "Guards (Operator Protection)" for more information.

## Machine Security System

If equipped, this message is used to verify the certification of the Machine Security System (MSS) as a RF transmitter. The following specifications are provided to aid in ensuring compliance with all local regulations:

Table 5

Field strength(1)	16.12 dB micro-amp/meter
Operating frequency range	134.2 kHz
Operating time(	0.055 seconds (1/18 second)

(1) Field strength at 10 meters

(2) The operating time is measured after the key switch is first activated.

## Operator Controls

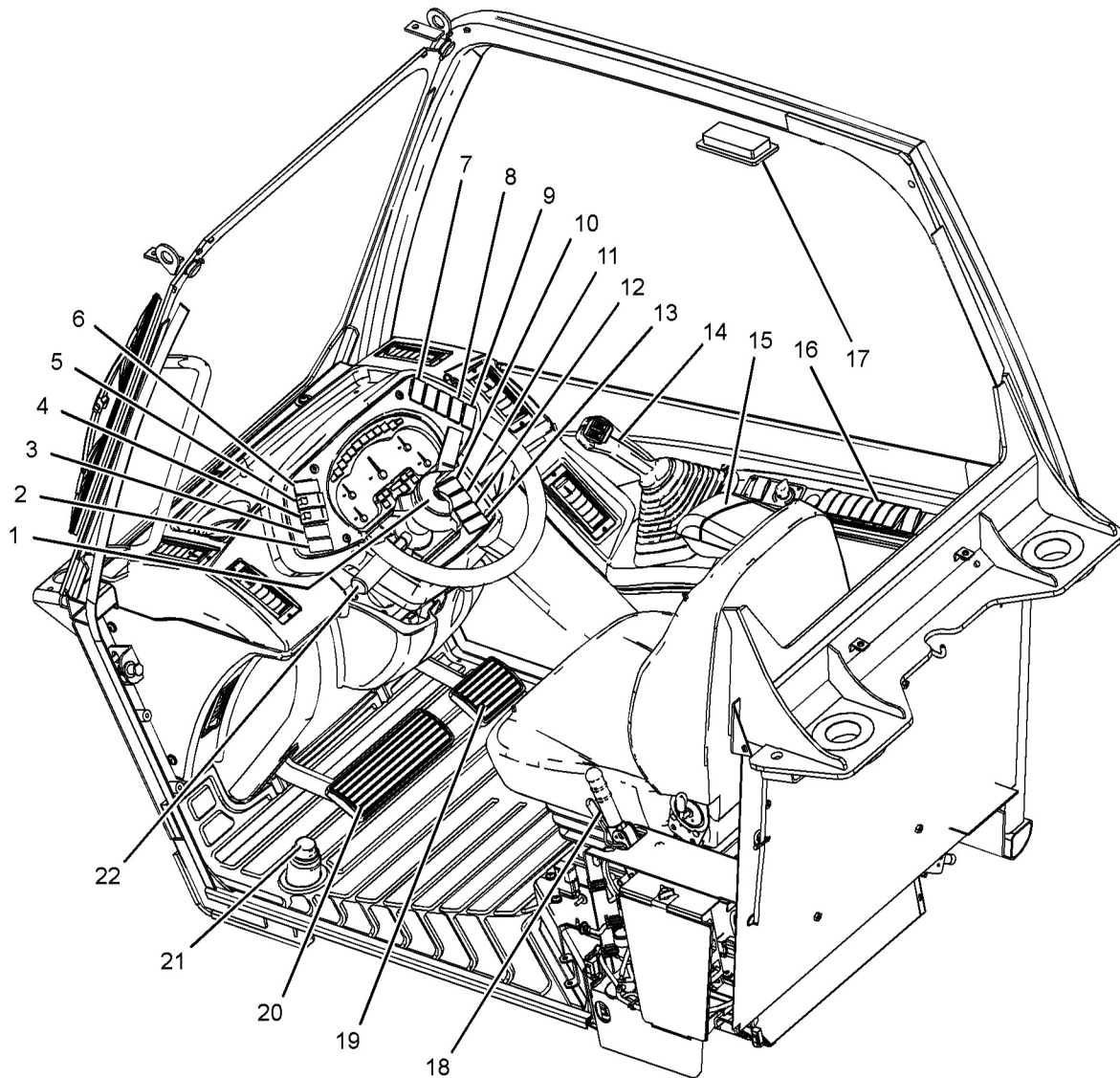

Illustration 56

g01213443

- |                                      |   |
|--------------------------------------|---|
| 1. Horn                              | 12. Headlight-Parking lights            |
| 2. Auto/Manual switch (if equipped)  | 13. Rotating beacon light               |
| 3. Quick coupler control             | 14. Joystick control                    |
| 4. Transmission neutralizer control  | 15. Adjustable armrest                  |
| 5. Steering mode control             | 16. Side console                        |
| 6. Reversible fan control            | 17. Interior light                      |
| 7. Frame leveling control            | 18. Parking and secondary brake control |
| 8. Continuous auxiliary flow control | 19. Accelerator control                 |
| 9. Fog lights                        | 20. Service brake control               |
| 10. Hazard flashers                  | 21. Differential lock control           |
| 11. Headlight dimmer switch          | 22. Transmission control                |

Armrest (15) is adjustable. In order to access the adjustment knobs for armrest (15), rotate armrest (15) upward.

In order to adjust the angle of armrest (15), rotate knob (15A). To increase the angle of the armrest, turn the knob clockwise. To decrease the angle of the armrest, turn the knob counterclockwise.

In order to adjust the height of armrest (15), loosen knob (15B), and raise the armrest to the desired height. To secure the armrest at the desired height, tighten the knob.

## Side Console (16)

The side console contains controls for the following features:

- Heating and air conditioning
- Window wiper and window washer
- Floodlights for the cab
- Boom floodlights
- Hydraulic towing hitch
- Hydraulic lockout control

Refer to Operation and Maintenance Manual, "Operator Controls (Side Console)" for more detailed information on each of these controls.

## Interior Light (17)

**Interior Light (if equipped)** - Press either side of the lens in order to turn on the interior light. Press the opposite side of the lens in order to turn off the interior light.

## Parking and Secondary Brake Control (18)

### Parking Brake

The parking brake is controlled by a hand operated lever (18) which is located at the left side of the seat.

**Note:** The parking brake operates on the front axle only.

Engage the parking brake after the machine has stopped and when the transmission control has been moved to the NEUTRAL position.

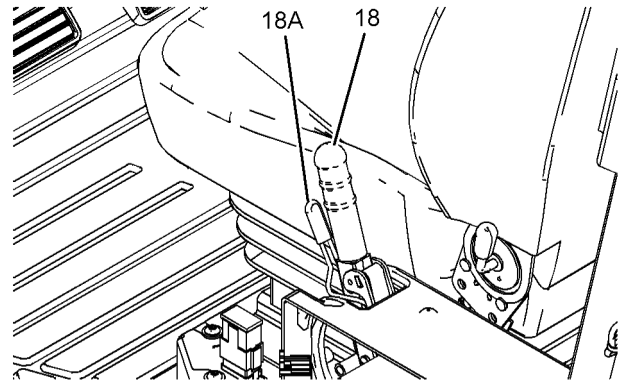

Illustration 74

g01147873

**Parking Brake Engaged** - Pull lever (18) fully upward in order to engage the parking brake. A latch is located at the rear of lever (18). When lever (18) is pulled fully upward, the latch will lock in order to hold the parking brake in the ENGAGED position. Engage the parking brake after the machine has stopped. When the parking brake is in the ENGAGED position, the transmission is neutralized.

**Parking Brake Disengaged** - Pull back lever (18) and pull lever (18A) in order to release the latch. Lower lever (18) to the DISENGAGED position.

**Note:** The parking brake has an interlock switch in order to prevent the machine from being driven through the brake. The machine will not move in either FORWARD or REVERSE when the parking brake is engaged. The machine will not move if the parking brake lever is slightly engaged.

### Secondary Brake

The parking brake also functions as a secondary brake. The parking brake must be used to bring the machine to a stop only if the service brakes fail to stop the machine. If the parking brake has been used as a secondary brake, do not move or operate the machine until the service brake system has been checked and any necessary repairs have been completed.

**Note:** The parking brake operates on the front axle only.

## Accelerator Control (19)

Accelerator control (pedal) (19) is located on the floor of the cab.

Depress pedal (19) in order to increase the engine speed.

Release pedal (19) in order to decrease the engine speed.

When you are travelling uphill, select a lower gear when the engine speed starts to fall. Drive the machine in the gear that will allow the required speed to be maintained.

## Hydraulic Quick Coupler

Your machine may be equipped with a hydraulic quick coupler.

Illustrations in the following procedure show a carriage which is equipped with forks. The procedure is applicable to all work tools with the same types of mounting points.

### Installation Procedure

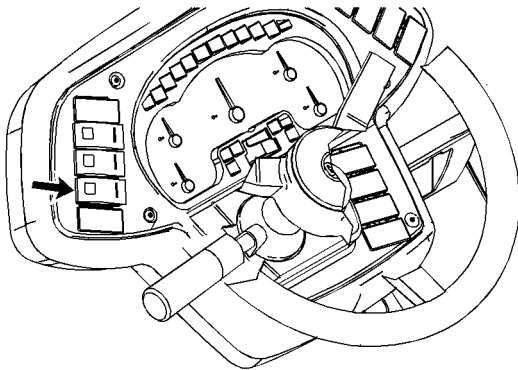

Illustration 85

g01060075

1. Move the red portion of the switch for the quick coupler downward and press the top of the switch. Hold the top of the switch until the quick coupler pins are fully disengaged. Release the switch.
2. Lower and extend the boom approximately 2 m (6.6 ft) so that the quick coupler can be seen from the cab. Position the quick coupler in line with the carriage.

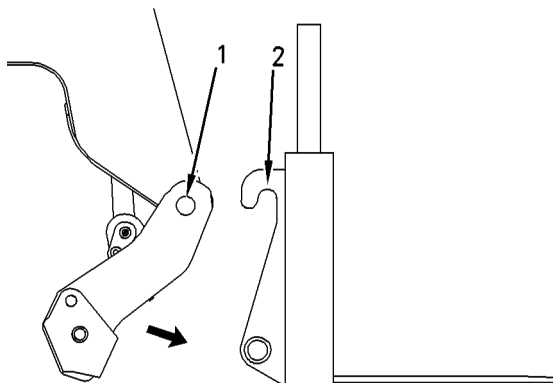

Illustration 86

g00975380

3. Tilt the quick coupler forward until the quick coupler tubes (1) are below the level of hooks (2).

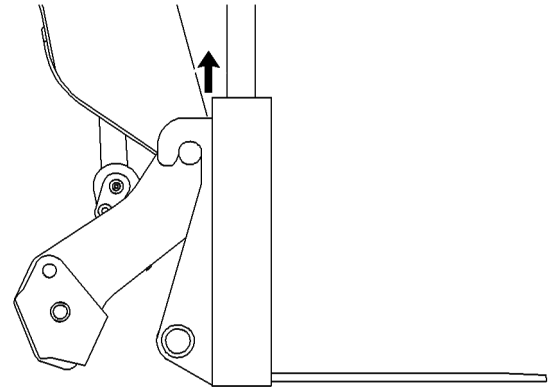

Illustration 87

g00975278

4. Extend the boom slowly until the quick coupler tubes contact the carriage. Raise the boom until the quick coupler tubes are engaged with the hooks.

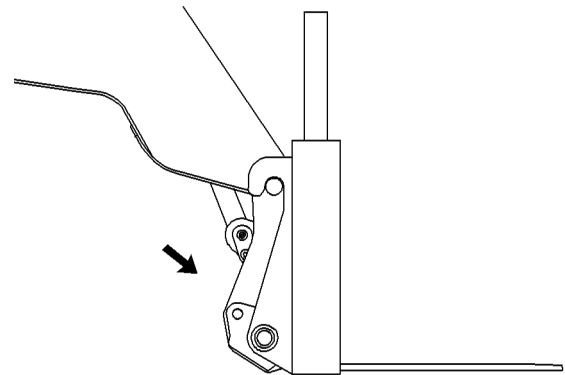

Illustration 88

g00975332

5. Tilt back the quick coupler until the lower part of the carriage is in contact with the quick coupler.
6. Press and hold the bottom of the switch for the quick coupler in order to engage the quick coupler pins. Release the switch after the pins are fully engaged.

### WARNING

An improperly installed work tool could become dislodged from the machine during operation. This could cause injury or death. Do not operate the machine until you have positive indication that the quick coupler pins are fully engaged.

CLICK HERE TO **DOWNLOAD** THE COMPLETE MANUAL

- Thank you very much for reading the preview of the manual.
- You can download the complete manual from: [www.heydownloads.com](http://www.heydownloads.com) by clicking the link below



- Please note: If there is no response to CLICKING the link, please download this PDF first and then click on it.

CLICK HERE TO **DOWNLOAD** THE COMPLETE MANUAL

Use tag lines to assist in the control of loads that require accurate placement.

When a load is lifted and the boom is extended and raised, the boom will deflect under the load. This has the effect of moving the load away from the machine as the load is raised. Make an allowance for this deflection.

Maneuver the load into position by operating the boom functions. Do not use the quick coupler to position the load when the material handling arm is installed.

## Hopper

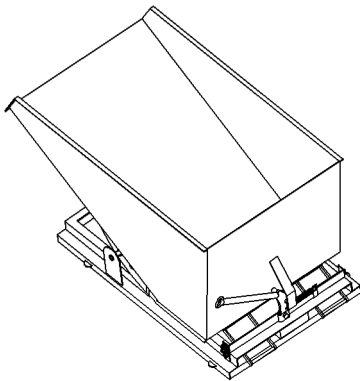

Illustration 121

g00974787

### Picking up the Hopper

Position the machine square to the hopper. Extend and lower the boom. The forks must enter the pockets of the hopper cleanly. The forks must be fully engaged with the pockets of the hopper.

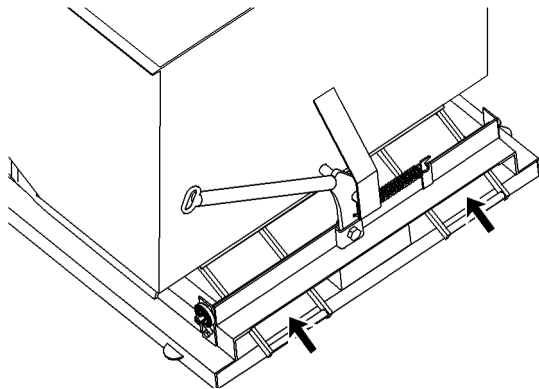

Illustration 122

g00974805

When the forks fully engage, a bar that is spring loaded will lock each fork in position. Establish that the forks are securely locked in place before you raise the hopper.

Before you raise the hopper, ensure that the latch for the trip lever is securely engaged.

Raise the hopper. Tilt the quick coupler slightly backward in order to better secure the hopper. Travel with the boom fully retracted so that you have good visibility and so that the machine has good stability.

### Discharging the Hopper

Travel the machine to the work area. Stop the machine and apply the parking brake. Lower the hopper.

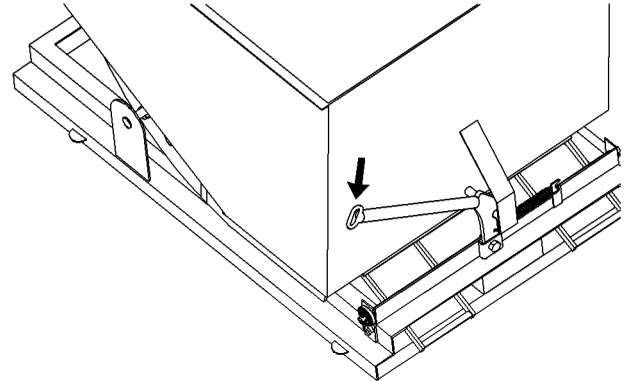

Illustration 123

g00974801

Pull down on the release lever.

The hopper will tilt forward and the load will be discharged.

To remove the hopper, lower the hopper to the ground. The bar that secures the forks in place will automatically disengage when the hopper is placed on the ground. Withdraw the forks from the pockets by retracting the boom.

### Utility Fork with Grapple and Ejector

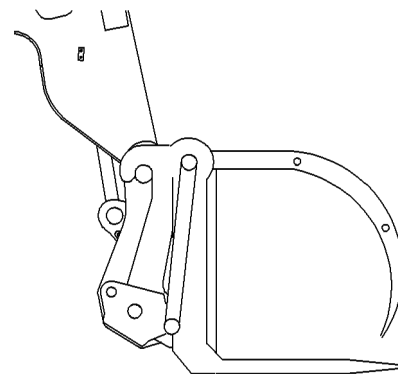

Illustration 124

g00974838

The forks are used to tear out material from a pile.

The fork with the grapple has the same function as the fork. The grapple is used for increased load retention.

The ejector dumps the load more efficiently.

5. Chock the wheels if the machine is parked on a slope.
6. Inspect the engine compartment for debris. Clean out any debris and any paper in order to avoid a fire.
7. Turn the key for the battery disconnect switch to the OFF position. When the machine is left for an extended period of one month, you should remove the key for the battery disconnect switch. Alternatively, the battery should be removed.
8. Close the engine enclosure and lock the engine enclosure.
9. Install all vandalism caps and covers before you leave the machine.

When the machine is left for an extended period of one month or longer, perform the following operations:

- Disconnect the battery and remove the battery.
- Relieve hydraulic pressure from the hydraulic system.
- Seal air intake and exhaust openings.
- Grease bright parts.
- Protect rubber components from direct sunlight.
- Fill the fuel tank.
- Ensure that the tires are correctly inflated.

## Transportation Information

### Shipping the Machine

Ensure that the combined weight of the machine and of the transport vehicle complies with local laws and regulations along the entire route.

Ensure that the intended route has adequate vertical clearances and horizontal clearances for the transport vehicle when the machine is loaded.

Remove ice, snow, or other slippery material from the transport vehicle, from the rail car, or from the loading dock before you load the machine.

Always chock the transport vehicle or the rail car wheels before you load the machine.

The boom must be fully retracted. The boom must also be lowered until the quick coupler or the work tool is resting on the transport vehicle.

#### NOTICE

Obey all state and local laws governing the weight, width and length of a load.

Make sure the cooling system has proper antifreeze if moving machine to a colder climate.

Observe all regulations governing wide loads.

Refer to Operation and Maintenance Manual, "Specifications" for the basic dimensions and the weights for shipping a standard machine.

### Roading the Machine

Check with the proper officials in order to obtain the required licenses and other similar items.

Inflate the tires to the correct air pressure. Use a self-attaching inflation chuck and stand behind the tire tread during the inflation. Refer to Operation and Maintenance Manual, "Tire Inflation - Check".

Only operate the machine in two-wheel steer mode when you are roading a machine. Refer to Operation and Maintenance Manual, "Operator Controls" for more information.

Travel with the boom fully retracted and the boom lowered as far as possible while you are maintaining an adequate ground clearance for the coupler or for the work tool. Locking out the boom and auxiliary functions before roading the machine is a legal requirement in some countries. For information on locking out all boom and auxiliary hydraulic functions, refer to Operation and Maintenance Manual, "Operator Controls".

Travel at a moderate speed. Observe all speed limitations when you road the machine.

Do not allow the positive cable clamps to contact any metal except for the battery terminals.

9. Connect the other positive end of the jump start cable to the positive cable terminal of the electrical source.
10. Connect one negative end of the jump start cable to the negative cable terminal of the electrical source.
11. Finally, connect the other negative end of the jump start cable to the frame of the stalled machine. Do not connect the jump start cable to the battery post. Do not allow the jump start cables to contact the following components: the fuel lines, the hydraulic lines, and any moving parts.
12. Start the engine of the machine that is being used as an electrical source or energize the charging system on the auxiliary power source.
13. Wait at least two minutes before you attempt to start the stalled machine. This will allow the batteries in the stalled machine to partially charge.
14. Attempt to start the stalled engine. Refer to Operation and Maintenance Manual, "Engine Starting" for the correct starting procedure.
15. Immediately after you start the stalled engine, disconnect the jump start cables in reverse order.

## Equipment Lowering with Loss of Hydraulic Power

### WARNING

Lowering the boom with the engine stopped could cause personal injury or death.

Keep all personnel away from the boom drop area when lowering the boom with the engine stopped.

### WARNING

Personal injury could result from not following the specified procedure.

To avoid personal injury, follow the procedure as specified.

### WARNING

Lowering a raised boom increases the outreach of the load. This could reduce the forward stability of the machine resulting in machine tip over. This could cause injury or death to the operator or other personnel in the work area. Always retract the boom, if possible, before lowering it.

The cylinder for retracting the boom, and the cylinder for lowering the boom are equipped with load control valves. The load control valves lock oil in the cylinders if hydraulic power is lost. The locked oil in the cylinders prevents the boom from moving.

In most situations, the boom can be retracted and the boom can be lowered from ground level if hydraulic power is lost.

If the angle of the boom is too low you may not be able to retract the boom.

If the boom cannot be retracted, it might be possible to lower the load to ground level without retracting the boom first. Assess the weight of the load and consult the appropriate load chart in order to determine that the load can be lowered in this way without causing the machine to tip forward. Do not attempt to lower the boom unless you are satisfied with the stability of the machine. You must be sure that the boom can be lowered without hitting an obstacle.

Due to the size of the hydraulic tank, it is possible to return 12 L (3.17 US gal) of oil to the tank more than the tank capacity. This volume of oil must be removed by the following procedure before lowering the boom or retracting the boom from full stroke.

---

## Lubricant Viscosities and Refill Capacities

### Lubricant Viscosities

The proper oil viscosity grade is determined by the minimum outside ambient temperature. This is the temperature when the machine is started and while the machine is operated. In order to determine the proper oil viscosity grade, refer to the "Min" column in the table. This information reflects the coldest ambient temperature condition for starting a cold machine and for operating a cold machine. Refer to the "Max" column in the table in order to select the oil viscosity grade for operating the machine at the highest temperature that is anticipated. Unless specified otherwise in the "Lubricant Viscosities for Ambient Temperatures" tables, use the highest oil viscosity that is allowed for the ambient temperature when you start the machine.

Machines that are operated continuously should use oils that have the higher oil viscosity in the final drives and in the differentials. The oils that have the higher oil viscosity will maintain the highest possible oil film thickness. Consult your dealer if additional information is needed. Refer to the appropriate Service Manual for further information. Tire tread

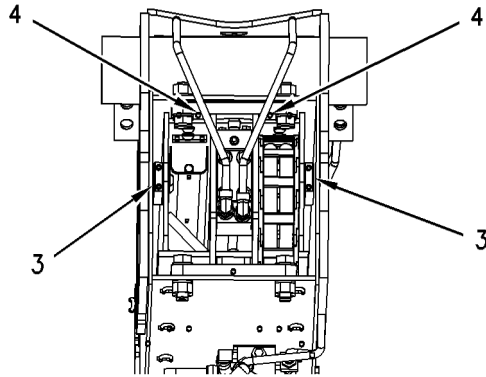

Illustration 188

g00999284

7. Remove the cover from the rear of the chassis and measure clearances (3) between the rear wear pads and the side of the boom sections at each side.
8. Measure clearances (4) between the rear wear pads and the top of the boom sections.
9. The clearance at each location must not exceed 1.5 mm (0.06 inch). If the clearances are excessive, adjustments must be made.

## Adjustment

**Note:** The bolts that secure different wear pads are not identical lengths. Do not mix the bolts. Clean all used bolts. Before installation, apply thread lock compound to bolts that secure wear pads.

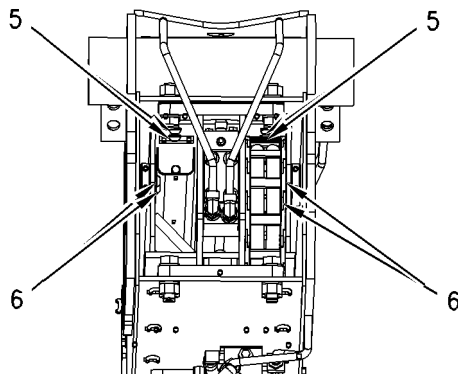

Illustration 189

g00999755

1. Remove bolts (5) that secure the rear top wear pads. Install sufficient shims in order to reduce the clearance to 0.75 mm (0.030 inch). Tighten the bolts to a torque of  $75 \pm 5$  N-m ( $55 \pm 4$  lb ft).
2. Remove bolts (6) that secure the rear side wear pads. Install sufficient shims in order to reduce the clearance to 0.75 mm (0.030 inch) at each side. Install sufficient shims in order to produce an equal clearance between the boom sections at each side. It may be necessary to install more shims at one

side than the other side. Tighten the bolts to a torque of  $75 \pm 5$  Nm ( $55 \pm 4$  lb ft).

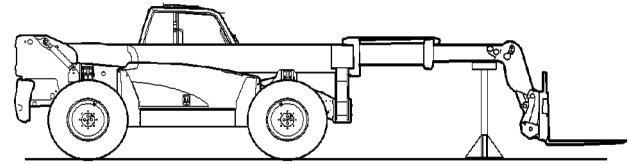

Illustration 190

g00857793

3. Raise the boom sufficiently above the stand. Fully extend the boom and lower the boom to the horizontal position. Support the boom under the second section.

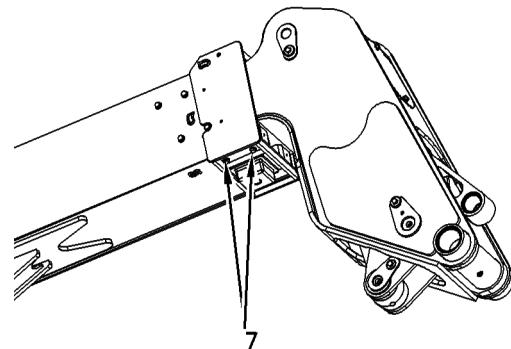

Illustration 191

g00999286

4. Remove bolts (7) that secure the bottom wear pads. Install sufficient shims in order to reduce the clearance to 0.75 mm (0.030 inch). Tighten the bolts to a torque of  $75 \pm 5$  Nm ( $55 \pm 4$  lb ft).

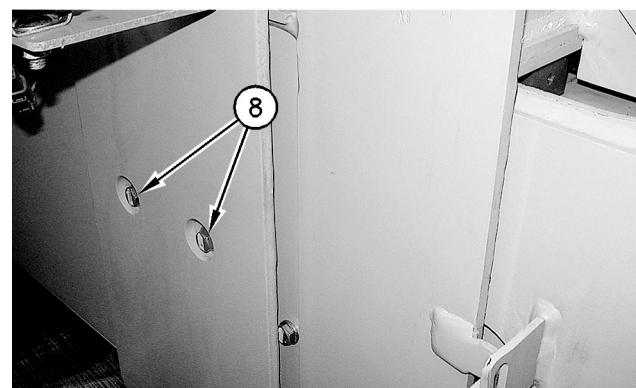

Illustration 192

g00865472

## Differential Oil - Change

### NOTICE

Care must be taken to ensure that fluids are contained during performance of inspection, maintenance, testing, adjusting and repair of the product. Be prepared to collect the fluid with suitable containers before opening any compartment or disassembling any component containing fluids.

Refer to Special Publication, NENG2500, "Caterpillar Dealer Service Tool Catalog" for tools and supplies suitable to collect and contain fluids on Caterpillar products.

Dispose of all fluids according to local regulations and mandates.

Park the machine on level ground. Fully retract the boom and fully lower the boom. Move the transmission control to the NEUTRAL position and ensure that the parking brake is engaged. Shut off the engine.

### Rear Axle Differential

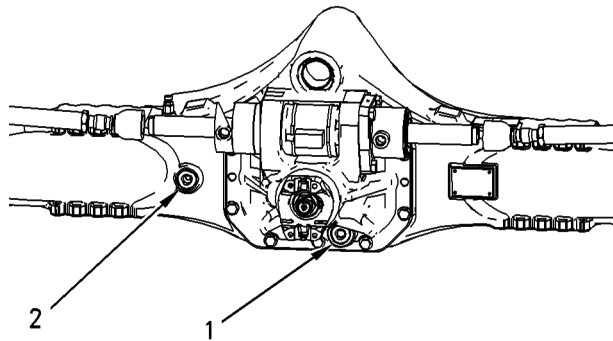

Illustration 222

g00952999

1. Clean the area around the plugs. Remove the following plugs for the rear differential:

- Drain plug (1)
- Combined level plug and filler plug (2)

Allow the oil to drain into a suitable container.

2. Clean drain plug (1) and reinstall drain plug (1).
3. Add new oil to the differential housing through filler hole (2) until the oil is level with the threads for plug (2). Refer to Operator and Maintenance Manual, "Lubricant Viscosities" for the correct grade of oil. Refer to Operation and Maintenance Manual, "Capacities (Refill)" and the appropriate Service Manual for more detailed lubricant information.

4. Clean combined level plug and filler plug (2).  
Reinstall combined level plug and filler plug (2).

### Front Axle Differential

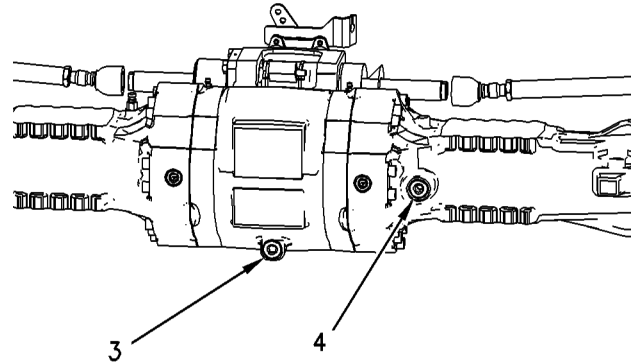

Illustration 223

g00953178

1. Clean the area around the plugs. Remove the following plugs for the front differential:

- Drain plug (3)
- Combined level plug and filler plug (4)

Allow the oil to drain into a suitable container.

2. Clean drain plug (3) and reinstall drain plug (3).
3. Add new 197-0017 Axle and Brake Oil Additive to the differential housing through hole (4). Refer to Operation and Maintenance Manual, "Capacities (Refill)" for more detailed information.
4. Add new oil to the differential housing through filler hole (4) until the oil is level with the threads for plug (4). When you are filling the front axle with oil you should allow time for the oil to drain through the differential into the other side of the axle. Ensure that the correct quantity of oil is added to the axle in order to fill the differential and the axle housing. Damage to the differential will result if this procedure is not observed. Refer to Operator and Maintenance Manual, "Lubricant Viscosities" for the correct grade of oil.

Refer to Operation and Maintenance Manual, "Capacities (Refill)" and the appropriate Service Manual for more detailed lubricant information.

5. Clean combined level plug and filler plug (4).  
Reinstall combined level plug and filler plug (4).

## Differential Oil Level - Check

### NOTICE

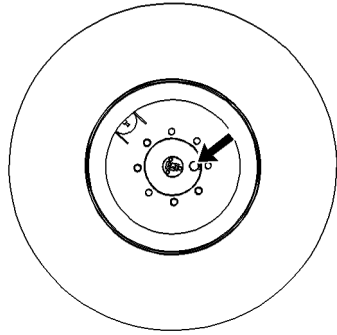

Illustration 246

g00952220

Fully retract the boom and fully lower the boom. Move the transmission control to the NEUTRAL position and engage the parking brake. Shut off the engine.

Obtain a sample of oil from each final drive. Keep the oil samples separate from each other.

Select a final drive in order to obtain a sample of oil. Park the machine on level ground and position the plug for the final drive on the horizontal center line of the wheel.

Clean the area around the plug and remove the plug. Use a sampling gun in the plug hole in order to obtain an oil sample from the final drive. Inspect the plug for damage. Install the plug.

Repeat this procedure for the remaining final drives. Analysis of oil from the corresponding final drive will provide an accurate representation of oil condition within each system.

Use SOS Oil Analysis in order to monitor the condition of your oil.

For additional information, refer to the appropriate Service Manual.

## Fork Leveling Cylinder Pin - Lubricate

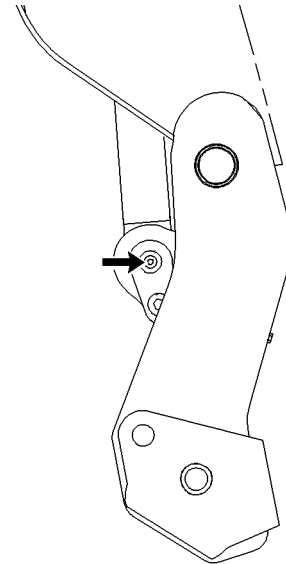

Illustration 247

g00977344

Lubricate the pin for the fork leveling cylinder through the fitting.

## Fuel System - Prime

### Tier II

1. Turn the engine start switch to the ON position. Leave the switch in the ON position for 3 minutes.

### NOTICE

Do not crank the engine for more than 30 seconds. Allow the starting motor to cool for two minutes before cranking again.

Turbocharger (if equipped) damage can result, if the engine rpm is not kept low until the engine oil light/gauge verifies the oil pressure is sufficient.

2. Start the engine. Allow the engine to operate at low idle until the engine runs smoothly.

**Note:** If additional priming is necessary, refer to the appropriate Service Manual for additional information.

## Refrigerant Dryer - Replace

### WARNING

Personal injury could result from contact with refrigerant.

Contact with refrigerant could cause frost bite. Keep face and hands away to help prevent injury.

Protective goggles must always be worn when refrigerant lines are opened, even if the gauges indicate the system is empty of refrigerant.

Always use precaution when a fitting is removed. Slowly loosen the fitting. If the system is still under pressure, release it slowly in a well ventilated area.

Personal injury or death can result from inhaling refrigerant through a lit cigarette.

Inhaling air conditioner refrigerant gas through a lit cigarette or other smoking method or inhaling fumes released from a flame contacting air conditioner refrigerant gas, could cause bodily harm or death.

Do not smoke when servicing air conditioners or wherever refrigerant gas may be present.

Use a certified recovery and recycling cart to properly remove the refrigerant from the air conditioning system.

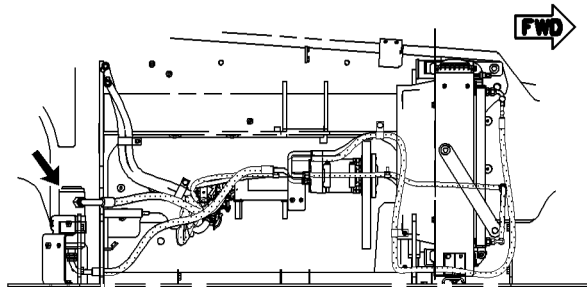

Illustration 268

g00980936

The refrigerant accumulator is located at the rear of the engine compartment.

**Note:** When you operate the machine in a climate with high humidity, replace the refrigerant accumulator after every 1000 service hours or 6 months.

## Rollover Protective Structure (ROPS) and Falling Object Protective Structure (FOPS) - Inspect

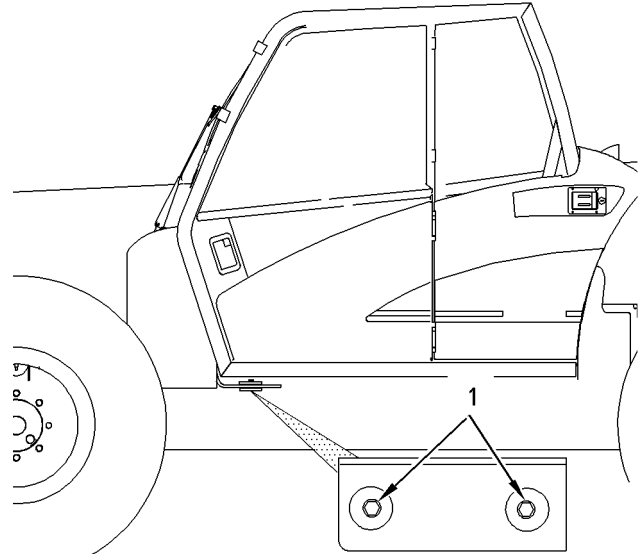

Illustration 269

g00950870

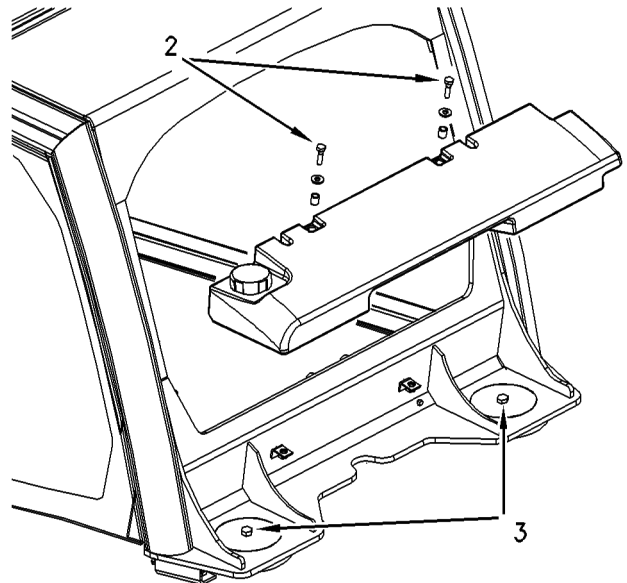

Illustration 270

g00951451

The front bolts (1) are located underneath the left side of the cab.

The rear bolts (3) are located underneath the windshield washer reservoir behind the cab.

1. Remove the bolts (2) in order to remove the windshield washer reservoir.
2. If the bolts are damaged or missing replace the bolts with original equipment parts only. Torque the bolts to 450 Nm (332 lb ft).

---

# Reference Information Section

## Approved Work Tools

 **WARNING**

**Use of non approved work tools on Telehandler machines could result in injury or death.**

**Before installing a work tool on this machine, ensure that it is approved by Caterpillar and that a Caterpillar load chart covering its use is installed in the machine's cab.**

### NOTICE

When certain work tools are fitted, the work tools can contact the front tires or the front fenders. This situation can occur when the boom is retracted and the work tool is rotated fully forward. Always check for interference when first operating a new work tool.

The work tools that are listed in these tables are approved by Caterpillar for use on the machines that are covered by this manual. The part number of the work tool is marked on the identification plate for the work tool. Use the following tables to determine that the work tool has been approved by Caterpillar. Additional work tools may have been approved since the publication of this manual. You must consult your Caterpillar dealer before using any work tool that is not in these tables. All work tools must be used in conjunction with the appropriate load chart. Use the following tables to ensure that you are using the correct load chart. You must know the load carrying capacity of these work tools. Make sure that you are using the correct load chart.

CLICK HERE TO **DOWNLOAD** THE COMPLETE MANUAL

- Thank you very much for reading the preview of the manual.
- You can download the complete manual from: [www.heydownloads.com](http://www.heydownloads.com) by clicking the link below



- Please note: If there is no response to CLICKING the link, please download this PDF first and then click on it.

CLICK HERE TO **DOWNLOAD** THE COMPLETE MANUAL