



Operation and Maintenance Manual

**6060 AC, 6060 AC FS
Hydraulic Shovel**

No.



CLICK HERE TO **DOWNLOAD** THE COMPLETE MANUAL

- Thank you very much for reading the preview of the manual.
- You can download the complete manual from: www.heydownloads.com by clicking the link below



- Please note: If there is no response to CLICKING the link, please download this PDF first and then click on it.

CLICK HERE TO **DOWNLOAD** THE COMPLETE MANUAL

1 INTRODUCTION

	Operation and Maintenance Manual	Target group
Part 1	INTRODUCTION FUNDAMENTAL SAFETY INSTRUCTIONS	Operating personnel + Inspection and servicing personnel + Repair personnel
Part 2	OPERATION	Operating personnel The operating personnel must have know-how relevant to the operation and the application of this or comparable machines.
Part 3	INSPECTION AND SERVICING	Inspection and servicing personnel The inspection and servicing personnel must have know-how relevant to the inspection and servicing of this or comparable machines.
Part 4	REPAIR WORK	Repair personnel The repair personnel must have know-how and experience relevant to the repair of this or comparable machines.
Part 5	ANNEX	Operating personnel + Inspection and servicing personnel + Repair personnel
Part 6	INDEX	Operating personnel + Inspection and servicing personnel + Repair personnel

Gas, dust, steam and smoke

Always start and operate the engine in a well-ventilated area;

If in an enclosed area, vent the exhaust to the outside;

Do not modify or tamper with the exhaust system

Diesel engine exhaust and some of its constituents are known to cause cancer, birth defects, and other reproductive harm

Operate fuel-operated heating systems only on adequately ventilated premises. Before starting the machine on enclosed premises, make sure that there is sufficient ventilation.

Observe the regulations in force at the respective site.

Carry out welding, flame-cutting and grinding work on the machine only if this has been expressly authorized, as there may be a risk of explosion and fire.

Before carrying out welding, flame-cutting and grinding operations, clean the machine and its surroundings from dust and other inflammable substances and make sure that the premises are adequately ventilated (risk of explosion).

Hydraulic / pneumatic equipment

Check all lines, hoses and screwed connections regularly for leaks and obvious damage. Repair damage immediately. Splashed oil may cause injury and fire.

Depressurize all system sections and pressure pipes (hydraulic / pneumatic system) to be removed in accordance with the specific instructions for the unit concerned before carrying out any repair work.

Hydraulic- and pneumatic lines must be laid and fitted properly. Ensure that no connections are interchanged. The fittings, lengths and quality of the hoses must comply with the technical requirements.

Noise

During operation, all sound baffles of the machine must be closed.

Always wear the prescribed ear protectors.

Oil, grease and other chemical substances

When handling oil, grease or other chemical substances, observe the product-related safety regulations (see safety specifications).

Be careful when handling hot consumables (risk of burning or scalding).

Transporting and recommissioning

The machine must be loaded and transported only in accordance with the Operation and Maintenance Manual.

Use only appropriate means of transport and lifting gear of adequate capacity.

The recommissioning procedure must be strictly in accordance with the Operation and Maintenance Manual.

FIRE AND EXPLOSION HAZARD

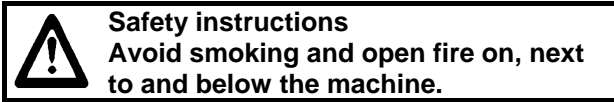

Combustible and easily flammable substances or liquids increase the fire and explosion hazard.

Do not store such substances on the excavator.

Clean the excavator thoroughly, if possible, with a steam jet (rubber parts and electric components with compressed air - refer to information label), when, for example, oil, grease, fuel or cleaner was spilled.

Such substances may spontaneously ignite if they get into the vicinity of hot units.

Even battery gases can ignite in open flames or fire.

Avoid parking the excavator in places where

- combustible substances such as coal dust or tar are present,
- open or smouldering fire may occur.

Remove the excavator from such an area where combustible or easily flammable liquids have spilled from the excavator onto the ground.

Flying sparks may cause fire on the ground that can spread to the excavator.

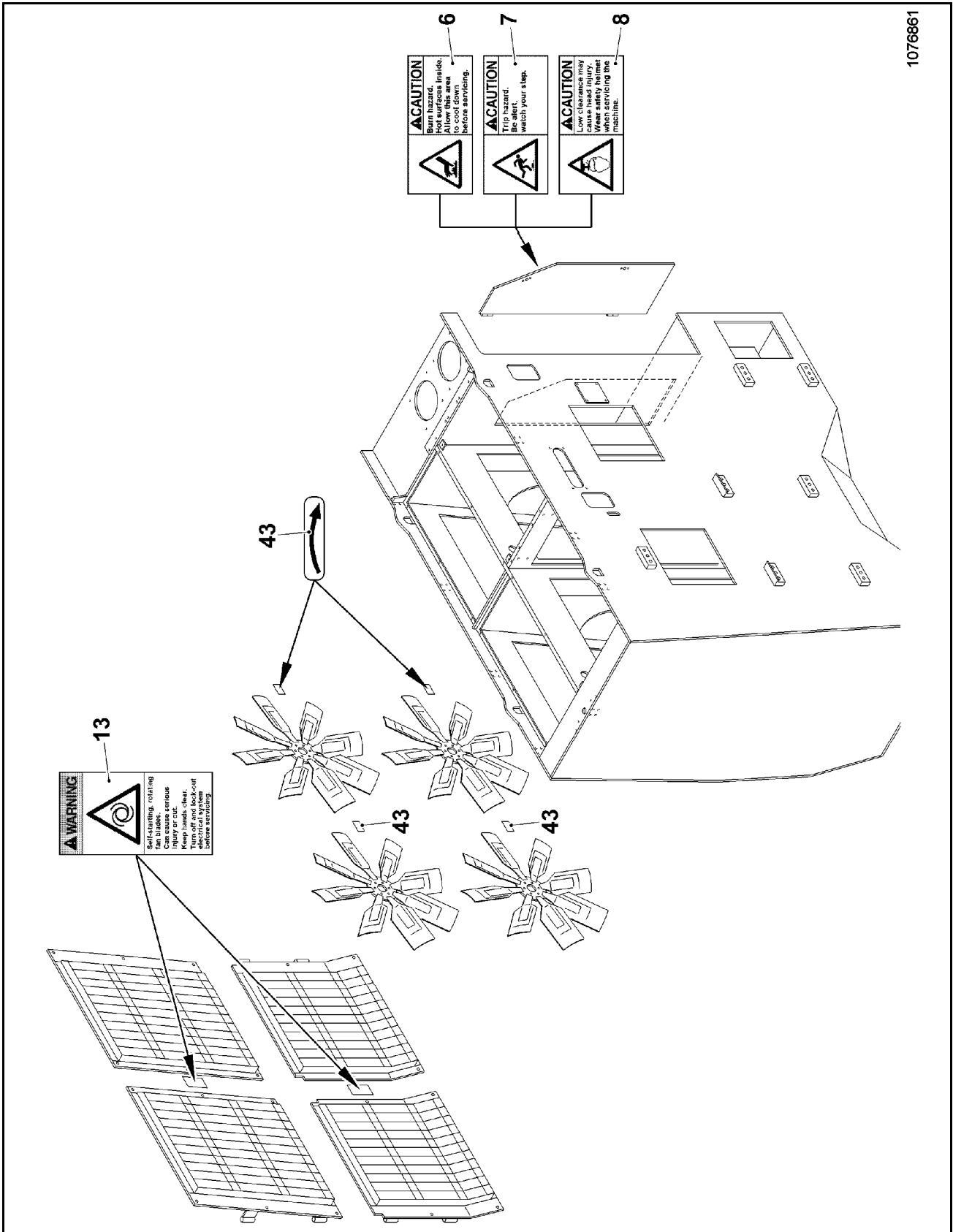

1076861

Fig. 2-9:

Switching the cab interior lighting on and off

The cab interior lighting can be switched on and off with the switches (arrow, Fig. 2-31:), (96, Fig. 2-32:) and (arrow, Fig. 2-33:)

The cab interior light is supplied with power even when the electrical system is shut down.

When leaving the machine, the interior light must therefore be switched off. The batteries could be discharged if the interior light is allowed to remain on for a prolonged period.

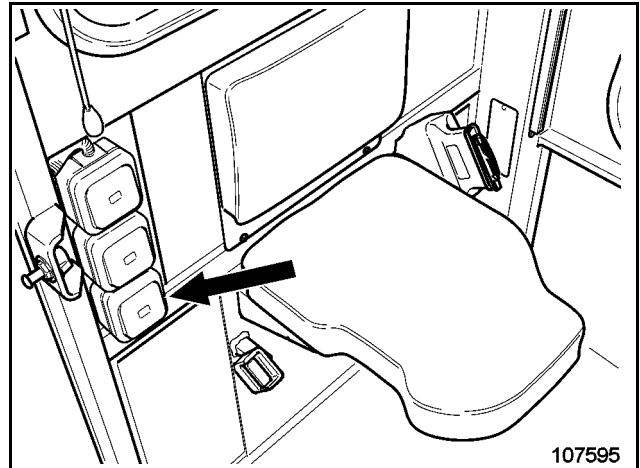

Fig. 2-31:

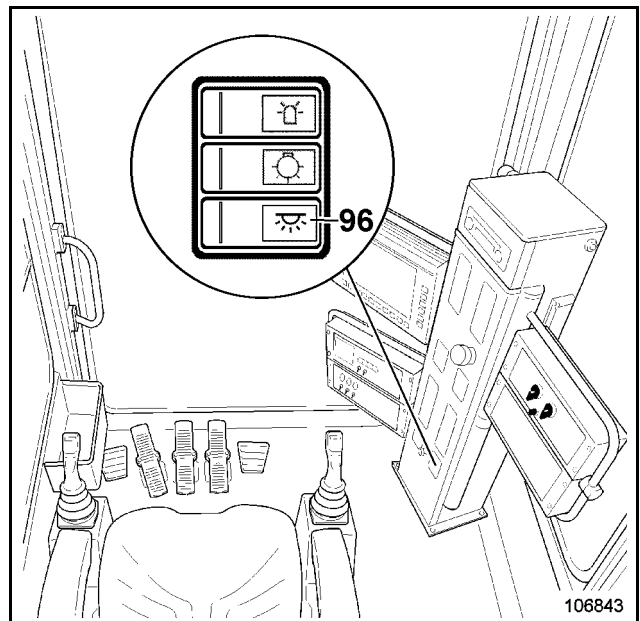

Fig. 2-32:

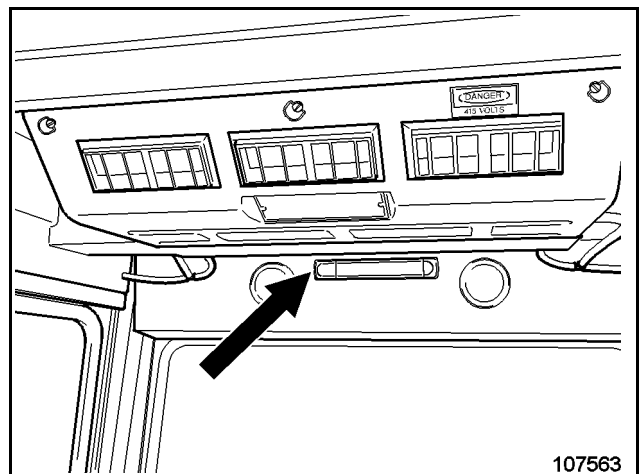

Fig. 2-33:

- Hang up loop (4, Fig. Fig. 2-55:) into snap hook (16).

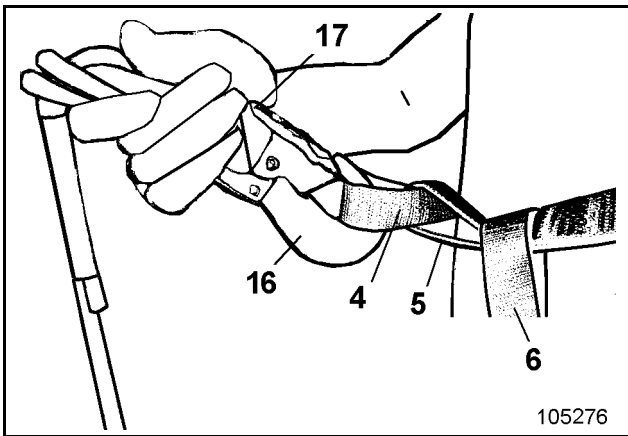

Fig. 2-55:

- Release hooking safety device (17, Fig. 2-56:).

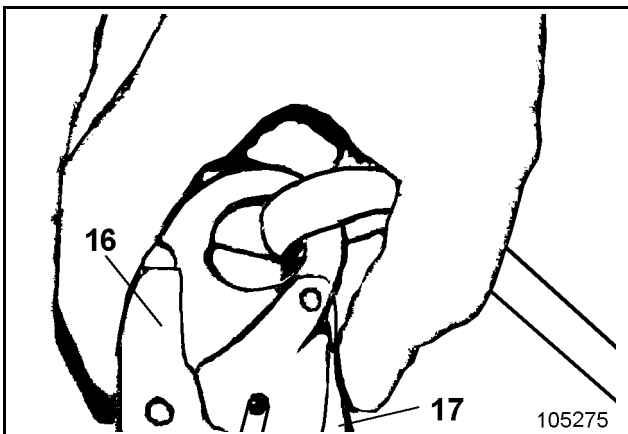

Fig. 2-56:

If you have the harness put on in such a way in case of danger you can escape from the excavator (Fig. Fig. 2-57:).

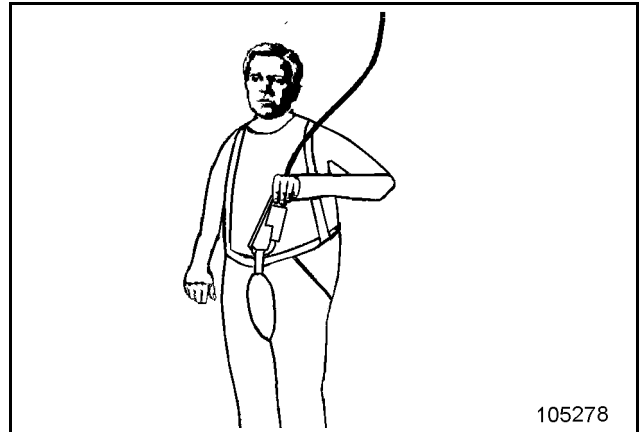







Fig. 2-57:

(Fig. 2-62:)

All switches and pushbuttons have an illuminated symbol face.

The opposite side is equipped with an LED. The LED lights up when the switch / pushbutton is actuated.

No.	Element	Function	Symbol
61	Push-button Superstructure hold- ing brake	Blocks the superstructure.  Press this button when the superstructure is stationary. Do not use this button while the superstructure is still in motion. Risk of damage to the brake and the swing gear-boxes.	
63	Push-button Hydraulic shovel parking brake, for Service and Maintenance purposes only	Press the switch face with the symbol: The parking brake is applied permanently. The hydraulic shovel cannot be moved. For more information refer to chapter "Track parking brake".  Actuate this switch only when the hydraulic shovel is stationary. Do not use this switch while the hydraulic shovel is still in motion. Risk of damage to the brakes and the travel gear-boxes.	
64	Push-button Central greasing system reset	Reset function of the central greasing system control (Press for at least 3 sec.). Press switch face without symbol: Resets the control of the superstructure. Press the switch face with the symbol: Resets the control of the undercarriage.	
65	Push-button Emergency lowering	Lowering of the working equipment in an emergency situation. For instance, if the electric motor has failed. For more information refer to chapter "Emergency lowering of the working equipment".	

Assemblies resp. reservoirs	Measuring device	Remarks
Pump drive gearbox	Dipstick (1, Fig. 2-68:)	Stop filling when the oil reaches the "max" mark on the dipstick (see Part 3, chapter "Pump drive gearbox - Checking the gearbox oil level/Filling in oil").
Hydraulic oil tank	BCS monitor (Fig. 2-71:), Inspection glass (1, Fig. 2-69:), sign (2, Fig. 2-69: and Fig. 2-70:)	<p>Checking the oil level:</p> <p>Extend the piston rods of stick and bucket cylinders halfway and stand working equipment on the ground (as shown on sign 2, Fig. 2-70:).</p> <p>Check oil level at an oil temperature of ca. 50 °C (122°F), with the electric motor shut off.</p> <p>Fill in oil when the oil level in the inspection glass has dropped below the "min" mark. Stop filling if the oil reaches the "max" mark on the inspection glass or the acoustic warning signal "Travel alarm" sounds (see chapter "Hydraulic system - Checking the hydraulic oil level / Refilling hydraulic oil").</p>

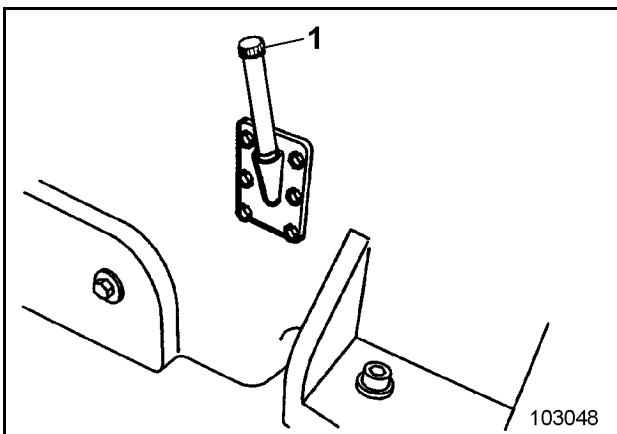

Fig. 2-68:

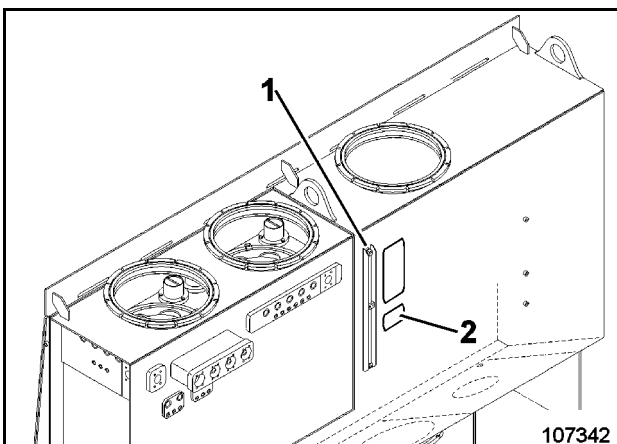

Fig. 2-69:

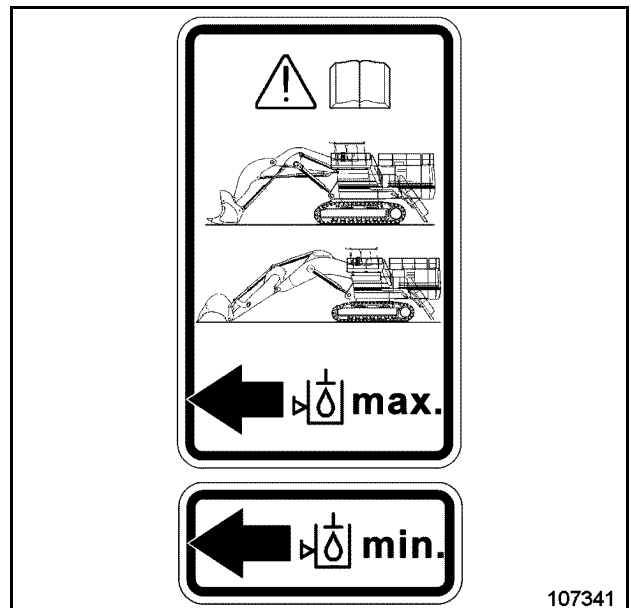

Fig. 2-70:

TRAVELLING, SAFETY INSTRUCTIONS

Have the attachment raised only so far as to permit the machine to be driven under overhead power lines without any risk.

Close the cab door.

If the machine is fitted with a safety belt for the operator, fasten the belt.

If the superstructure is turned by more than 90° from the BASIC POSITION, the excavator travels in the opposite direction to that selected.

If the position of the superstructure in relation to the undercarriage is not exactly known, touch the accelerator lightly to see which direction the machine takes, before initiating the full travelling movement.

Warn persons in the immediate vicinity by sounding the horn before setting off.

Never drive across slopes.

Take the utmost care on slippery, greasy ground.

If the machine is to be driven a longer distance, the superstructure must be secured against turning by means of the superstructure holding brake.

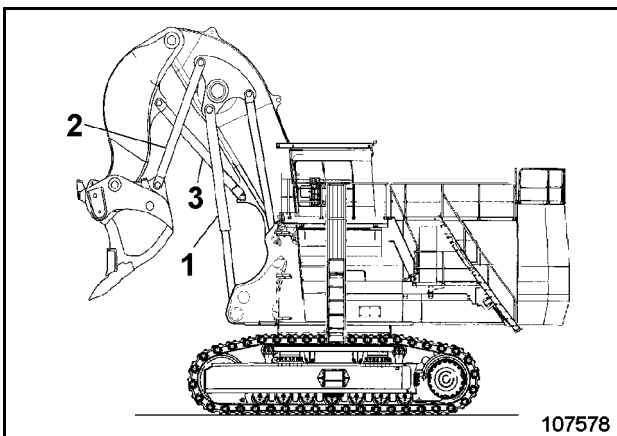

Fig. 2-87:

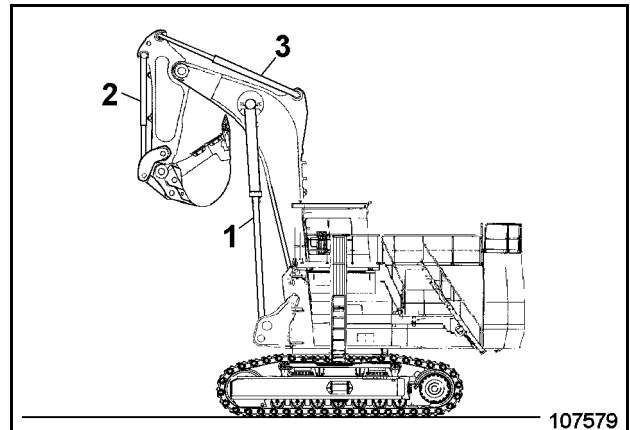

Fig. 2-88:

Running-in specifications for components of the crawler tracks

Prior to initial commissioning and/or after repair work, run in the idlers, track rollers and support rollers as follow:

- Raise the equipment (Fig. 2-87:) or (Fig. 2-88:).
- Drive the excavator in revers approx. 50 m / 164ft.
- Drive the excavator in forwards approx. 50 m / 164ft.
- Stop the excavator.
- Measure the temperature at each idler, track roller and support roller with an infrared thermometer (at a temperature of approx. 100° C / 212°F wait for idlers, track rollers and support rollers to cool down).
- Repeat this running-in procedure up to 10x.
- Check all idlers, track rollers and support rollers for leaks.

Trailing cable



Never touch the trailing cable.

Risk of voltage drive, if the trailing cable insulation is defective!

Change the position of the trailing cable only by means of a cable hook.

Swinging the superstructure

Swinging of the superstructure is possible only when:

- the superstructure holding brake is released and
 - the hydraulic shovel operator is sitting on his seat and
 - the hydraulic ladder is raised and
 - the servicestation (tanklift) is raised and
 - the BCS swing circuit test was successful.
- ➔ To swing the superstructure to the right - move control lever to the right (115, Fig. 2-108:).
- ➔ To swing the superstructure to the left - move control lever to the left (115).

After releasing, the control lever returns automatically to position "0".

Releasing the control lever (115) is not sufficient to brake the superstructure automatically. In order to brake the superstructure, the control lever must be moved in the direction opposite the swinging movement (reversing).

Braking the superstructure

The superstructure can only be braked by moving control lever (115) in the direction opposite the swinging movement (reversing).

⚠ The superstructure does not stop automatically by simply releasing the swing control lever (115).

To brake the superstructure, the swing control lever (115) must be moved in opposite direction.

In an emergency, activate the holding brake by pressing switch (61, Fig. 2-109:).

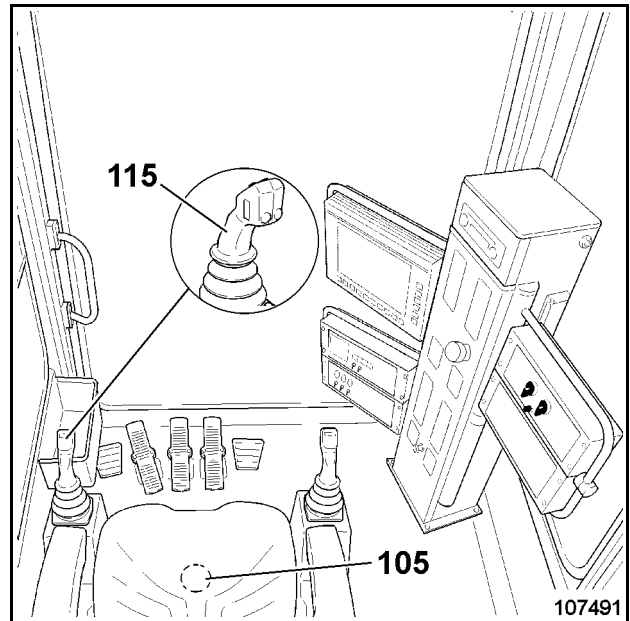

Fig. 2-108:

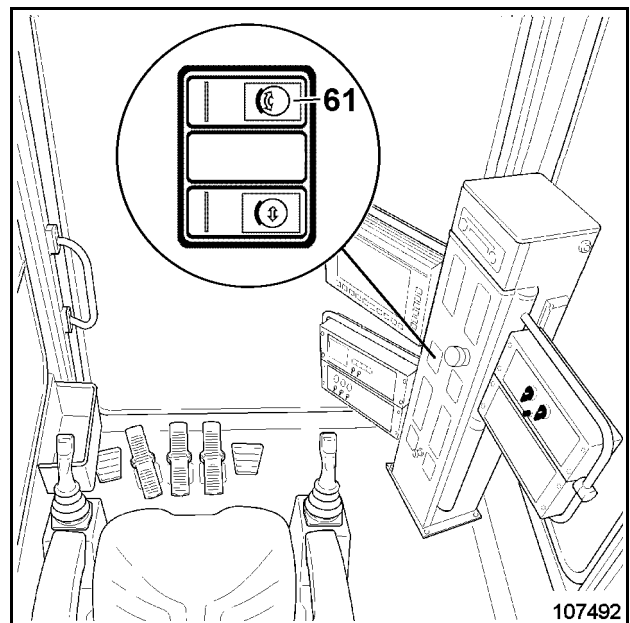

Fig. 2-109:

Monitoring cameras

This excavator is equipped with two monitoring cameras:

- one mounted on the counterweight, looking backwards;
- one mounted on the hydraulic oil cooler module, looking to the right.

The two cameras and the belonging LCD-diplay are operational after the electrical system of the machine has been activated with the key operated switch.

Both cameras transmit their images to the same LCD-display. The display is mounted near the control column.

For toggling between the camera images beeing displayed, press the key in the left joystick (arrow, Fig. 2-118:).

Additional information can be found in the manuals of the camera manufacturer (see Volume 5 of the Technical Documentation "Components").

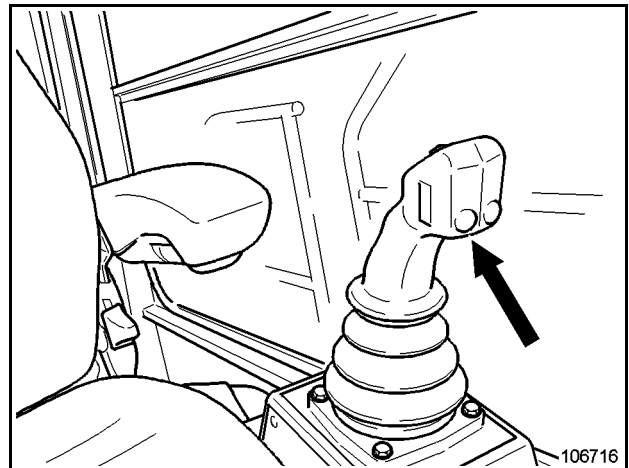

Fig. 2-118:

Selecting oils and greases

Use the recommended qualities only, matching viscosities with the temperature level.

Filters

Replace / clean all filter elements or filter cartridges within the specified periods.

All filters are coordinated carefully with the equipment. Original CGM HMS GmbH parts must be used to ensure smooth running and a long service life of the engine and the hydraulic units.

Sealing elements

When dismantling parts, watch for sealing elements.

Check sealing elements prior to installation and replace any that are even slightly damaged.

When assembling, ensure a perfect fit.

Oil-level check and oil change

Position the machine horizontally.

Change the oil when the machine is at operating temperature. Warm oil flows better and carries suspended particles (carbon or abraded matter) better.

Lubricating

Clean the lubricating nipple, then lubricate as scheduled.

After servicing

To prevent corrosion, coat all bright metal parts with a grease film.

On completing work, re-install all protective devices.

Never switch on the electric motor while work is being done on the machine.

Carry out performance tests with the machine.

CLICK HERE TO **DOWNLOAD** THE COMPLETE MANUAL

- Thank you very much for reading the preview of the manual.
- You can download the complete manual from: www.heydownloads.com by clicking the link below



- Please note: If there is no response to CLICKING the link, please download this PDF first and then click on it.

CLICK HERE TO **DOWNLOAD** THE COMPLETE MANUAL

Plan A – E

Plan **A** - after every 250 OH
 (at 250, 750, 1250 ... OH)

Plan **B** - after every 500 OH
 (at 500, 1500, 2500 ... OH)

Plan **C** - after every 1000 OH
 (at 1000, 2000, 3000, 4000 ... OH)

Plan **D** - after every 5000 OH
 (at 5000, 15000, 25000 ... OH)

Plan **E** - after every 10000 OH
 (at 10000, 20000, 30000, ... OH)

Page 1 of 6

Location	Servicing work	Menge / No.	Plan A	Plan B	Plan C	Plan D	Plan E	
Servicing in acc. with W or T			●	●	●	●	●	
Monitoring, warning and control elements - Joysticks - Control spool, plate, cardan joint - Pedals - Control spool (machine with loading shovel)	Grease lightly	2 x 4 ⁵			●	●	●	
	Grease lightly	3 x 2 ⁵			●	●	●	
Electric motor (See Electric motor manufacturer's servicing instructions for further details.) Rotor (inside and outside of machine) Terminals Coupling Screwed / bolted connections	Grease bearings (see plate with lubricating instructions at the electric motor for detailed information) Check for vibration	2		●	●	●	●	
	Visual inspect interior of machine for degree of dirt deposits			●	●	●	●	
	Visual inspect all accessible places for rust							●
	Check tightness			●	●	●	●	
	Check for degree of dirt deposits					●	●	●
	Check for alignment and record measurements ⁶							●
Check condition and tightness					●	●		
Operator's cab - Fastening bolts to cab module	Check for tightness (see Service Manual for tightening torques)				●	●	●	

⁵ apply a thin layer of low temperature grease

⁶ Check for alignment after every 2000 OH (refer to electric motor manufacturers servicing instructions)

Inspection plan – Oil (legend)

No.	Location	Number	Lubricant properties ¹⁵	Check oil level every ... OH	Change oil every ... OH
1	Hydraulic system	1	II	10	10000 ¹⁶
2	Pump drive gearbox and cooling circuit	1	III.a	60	1000
2	Pre-chambers, expansion reservoir	1		10	1000
3	Swing gearbox	4	III.b	10	1000
4	Travel gearbox	2	III.a	500	5000
	- Pre-chamber (only at gearbox PN 3783483)	2 x 1		500	5000
	- Brake-chambers	2 x 2		500	5000
5	On-board crane (optional)		I		
	- Crane drive engine	1		10	250 ¹⁷
	- Hydraulic oil reservoir	1		10	1000 ¹⁸

¹⁵ see "LUBRICANTS" section

¹⁶ Change hydraulic oil every 5000 OH unless the oil is analyzed at regular intervals, but not later than every 3 years.

¹⁷ Change oil at least once a year.

¹⁸ Change hydraulic oil at least once a year.

ELECTRIC MOTOR

Electric motor - Safety instructions



Read and observe: "Inspection and Servicing – Safety Instructions" and the electric motor Operation and Maintenance Manual.

Secure the machine as described in the "Securing the machine" section.

Wear protective gloves and firm working clothing.

- ➔ Switch off electric motor, to do so actuate switch (42, Fig. 3-11:).
- ➔ Set servicing switch (4, Fig. 3-12:) to locked position and secure in this position with a padlock.

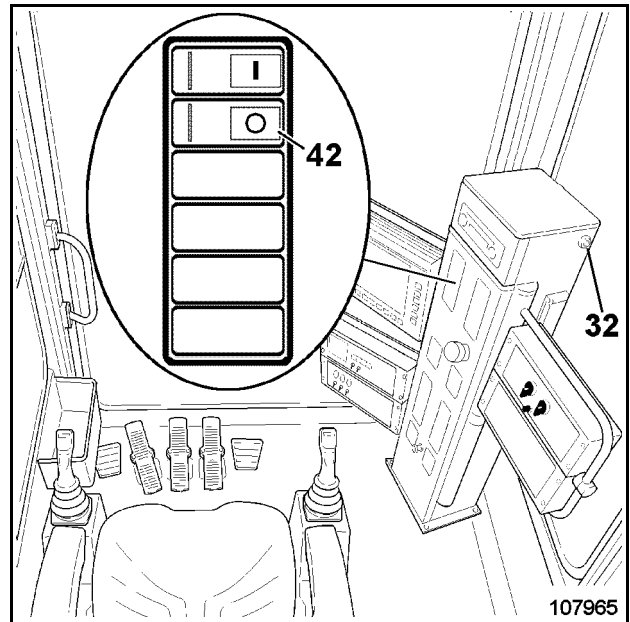

Fig. 3-11:

Cleaning the electric motor

Clean the electric motor, the cooling fins, bearing shields and ventilators from dust with compressed air, brushes and clothes only.

Remove the fan guard before cleaning the ventilator fan. Install it after cleaning.

Don't damage the protective coating while cleaning the electric-motor.

For more information see the manufacturers manual for the electric motor.



It is not permissible to clean the electric motor or any live excavator components with a steam cleaner and steam jet.

- ➔ After finishing work on the electric motor remove the padlock from servicing switch (4, Fig. 3-12:) and unlock.

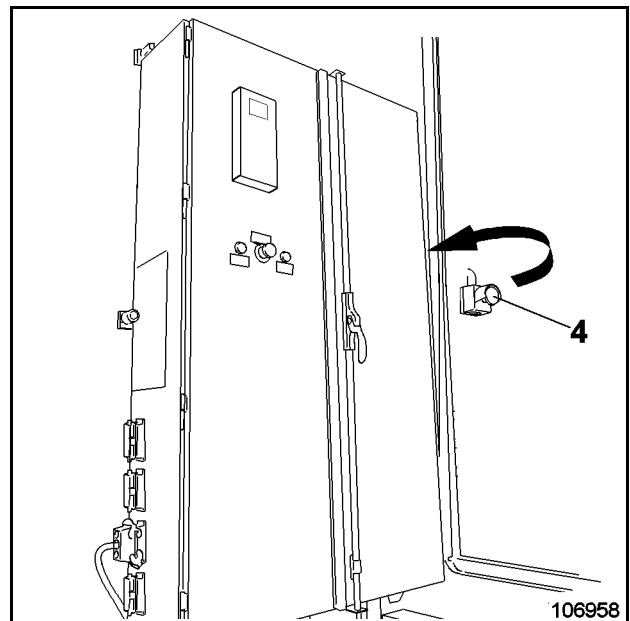

Fig. 3-12:

Lighting systems in LED technology, instructions

The lights of the maintenance lighting system (Fig. 3-25) as well as the working floodlights (Fig. 3-26) are equipped with lamps in LED technology (light-emitting diodes).

High-performance LEDs ensure the emission of light with high luminance. If the light is allowed to shine directly into the eyes from a short distance and over prolonged periods, there is a risk of injury to the retina.

Do not look for a prolonged period into the light cones of the LEDs.

Adjust the lights in such way that they do not shine directly into the eyes and that you are not blinded by the glare.



The lights become hot in operation. The heat is dispersed via the ribbed metal housing.

For this reason, the housings must not be covered up and cleaning rags or similar things placed over them.

The high-performance LEDs in these lights have a very long service life and can therefore not be replaced. If one or more of these LEDs fail, the light can remain in service if the remaining luminance is still sufficient.



Fig. 3-25



Fig. 3-26

Filter (servo control circuit), replace



Risk of scalding caused by hot hydraulic oil.

The filter housings themselves may also be hot.

Wear protective gloves and firm working clothing.

Skin contact with hydraulic oil may cause skin injury. Avoid skin contact.

Read and observe the "Inspection and servicing – Safety instructions" chapter.

- Shut off the electric motor.
- Depressurize the hydraulic system.
- Clean the filter housings as well as the immediate vicinity carefully.
- Dispose of waste oil, used filters and oil-stained cleaning rags properly and separated from other waste.

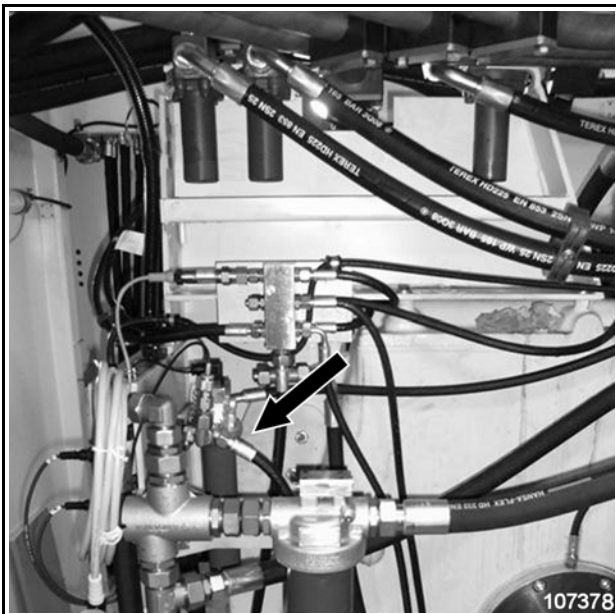

Fig. 3-49:

Replacing the filter element

To filter the hydraulic oil in the control circuit, the machine is equipped with a high-pressure filter (arrow, Fig. 3-49:).

Change filter element regularly and when the BCS indicates a contamination.

- Place a suitable collecting recipient under the filter housing (Fig. 3-49:).
- Collect escaping hydraulic oil and used filter elements. Discard without polluting the environment.
- Unscrew filter housing (5, Fig. 3-50:) by counterclockwise rotation. Pour out the oil.
- Withdraw filter element (6) from filter housing (5).
- Check filter housing (5) as well as used filter surface for debris.
- Clean filter housing (5) and the sealing face at the filter head with white spirit or paraffin oil.
- Check seals (8) and replace, if required.
- Screw in the filter housing (5) to stop. Then turn out the filter housing by an 1/8 turn so that the filter housing is not stuck due to pressure pulsation and can be easily loosened in case of maintenance works.
- Check high-pressure filters for leaks after putting the hydraulic system back into operation.

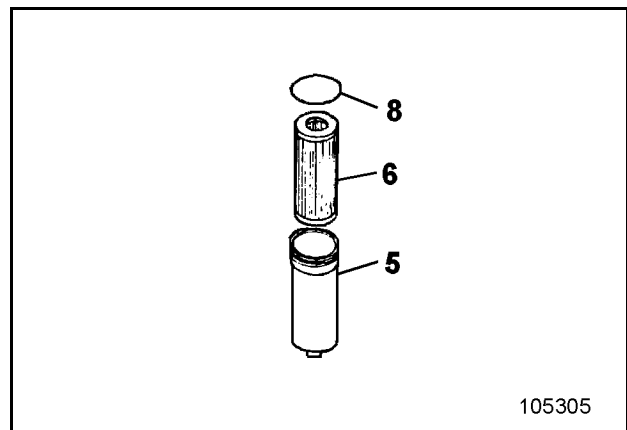

Fig. 3-50:

Pressure accumulator - Emergency lowering

To permit the working equipment to be lowered in an emergency, the machine is equipped with a pressure accumulator (1, Fig. 3-67:).

The pressure accumulator (1) is located in the superstructure and is accessible from the ground.

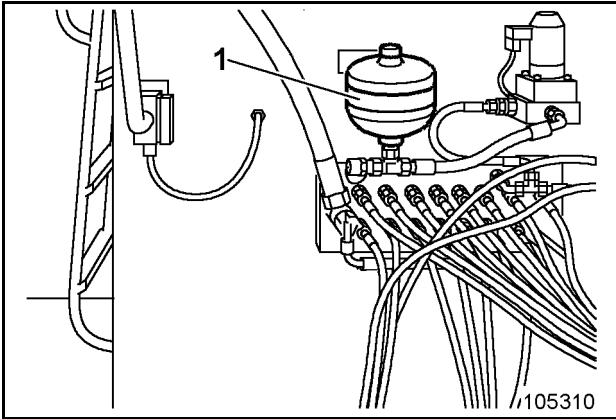

Fig. 3-67:

Pressure-accumulator inspection regulations



The following regulations are applicable only in Germany. Please observe the relevant regulations in force in your own country.

Extract from the German regulations

The accumulator vessel must not be subjected to welding, soldering or any other mechanical work. Work on systems containing accumulators (repairs, connection of pressure gauges or similar work) may be carried out only when the fluid pressure has been released

Extract from the German acceptance regulations

Hydraulic accumulators are pressure vessels and are therefore subject to the "Druckbehälterverordnung (DruckbehV)" [Pressure Vessel Regulations]. Their installation, equipment and operation are governed by the "Technische Regeln Druckbehälter (TRB)" [Technical Rules for Pressure Vessels]. The pressure vessels of hydraulic accumulators are classified by the admissible operating pressure p in bars, the capacity l in liters and the product of pressure and capacity $p \times l$. Depending on the class to which the accumulator belongs, the following inspections are mandatory:

Checking the gas charging pressure in the pressure accumulator

After commissioning (new installation or repair), the gas charging pressure in the pressure vessel must be checked at least once during the first week. If no pressure loss is detected, the second pressure test must be performed after ca. 3 months. If no pressure loss is detected in this test either, the testing interval can be fixed at once pressure test each year.

Group	Inspections prior to commissioning		Regular inspections
	at the factory	at the place of use	
II $p \geq 1$ bar and $p \cdot l \leq 200$	Pressure testing Prototype and pressure test certified by the manufacturer	Inspection certificate (Check of correctness and correct installation) issued by an expert	Inspection schedule to be drawn up by end user, based on experience with type of operation and fluid.

Travel gearbox - Changing oil

Carry out oil change when oil is nearly at operating temperature. All suspended particles and contaminations will be rinsed out with the old oil.

Draining off oil

- Move the hydraulic shovel into such a position that the screw plugs (1, 2 and 3, Fig. 3-85:) are in the displayed position.
- Place a collecting recipient for used oil under the travel gearbox.
Choose the required capacity in accordance with the "Refilling quantities - Oil" table.
- Unscrew drain plug (2) and drain off the oil completely.
Slackening plug (3) allows the oil to run out more readily.
- Clean screw plugs (2 and 3)
- Screw screw plug (2) back in place.

Filling in oil

- Unscrew screw plug (1 and 3).
- Fill in oil through opening in plug (3) until it flows out of opening in plug (1).
Oil grade see: „LUBRICANTS / CONSUMABLES“.
- Screw plugs (1 and 3) back in place.

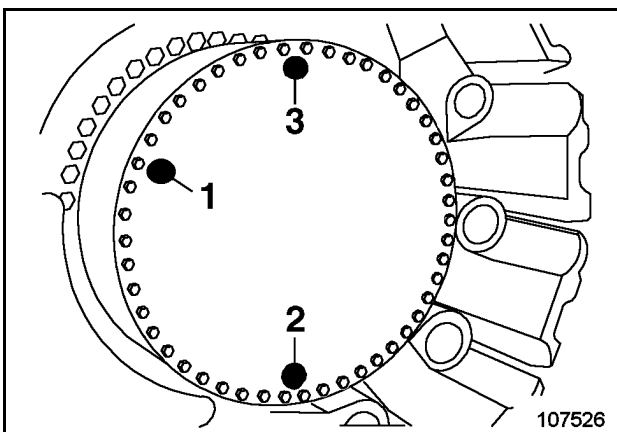

Fig. 3-85:

Spur gear section - Changing the oil / Draining off oil

- Place a collecting recipient for used oil under the pre-chamber.
Choose the required capacity in accordance with the "Refilling quantities - Oil" table.
- Unscrew drain plug (3, Fig. 3-86:) and drain off the oil completely.
Slackening plug (4) allows the oil to run out more readily.
- Clean screw plugs (3 and 4)
- Screw screw plug (3) back in place.

Filling in oil

- Unscrew screw plug (4).
- Fill in oil through opening of plug (4) until it reaches the center of the inspection glass (2).
Oil grade see: „LUBRICANTS / CONSUMABLES“.
- Screw plug (4) back in place.

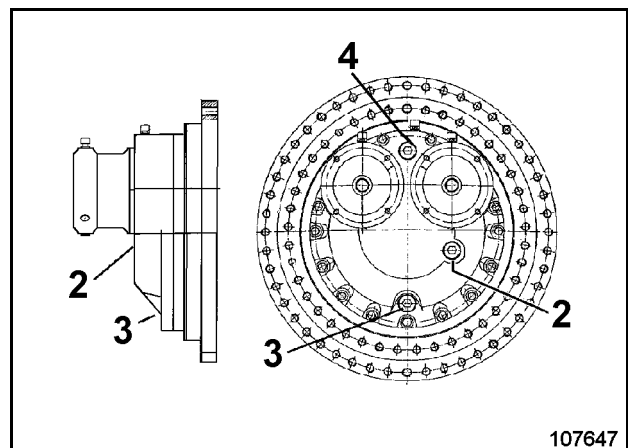

Fig. 3-86:

CRAWLER TRACKS

Cleaning

Clean tracks, track and support rollers, sprockets and idlers regularly and whenever required. Cleaning is especially important in winter to prevent

- the tracks from being thrown off
- oil from leaking out of track and support rollers, sprockets and idlers
- excessive wear
- the track from breaking.

To clean the tracks:

- Raise one side of the excavator with the working equipment and allow track to turn.
- Clean the side member supporting the track.
- Clean support and track rollers (1 and 2 ,Fig. 3-105:) thoroughly.
- Clean the sliding planes on the idler guides.

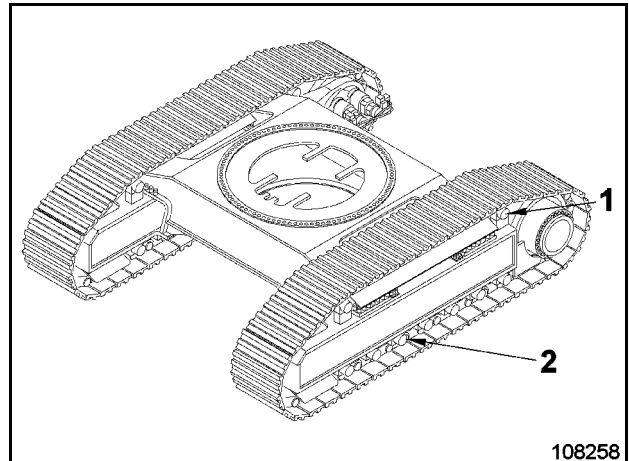

Fig. 3-105:

Checking the greasing pressure

(for machines with automatic greasing of the track rollers, optional)

Check every week, whether the oil pressure indicated by pressure gauge (4, Fig. 3-124:) is 60 bars / 870psi (the pressure is depending on temperature and viscosity of the oil and may vary).

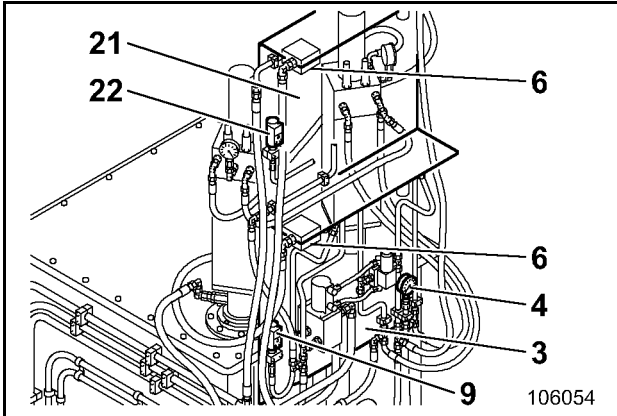

Fig. 3-124:

This oil pressure is reduced so that the pressure indicated by pressure gauge (2, Fig. 3-125:) is 35 – 40 bars (507-580psi) and by pressure gauge (4) is 49 – 51 bar (710-739psi).

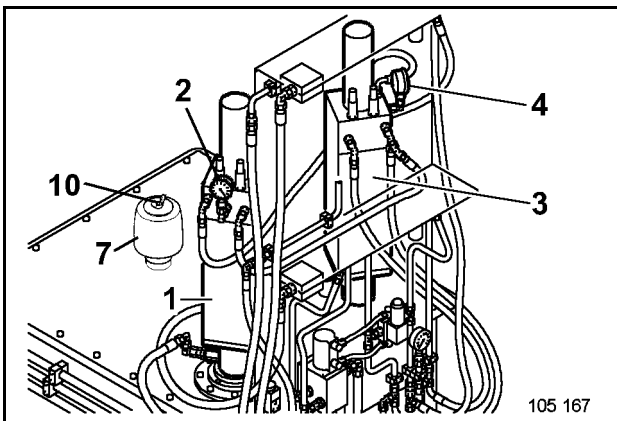

Fig. 3-125:

The necessary greasing pressure of 320 bar / 4641psi for the superstructure and 180 bar / 2610psi for the lundercarriage is generated by means of a pressure translator.

The greasing pressure for the superstructure is indicated by pressure gauge (9, Fig. 3-124:) and for the undercarriage by pressure gauge (22).

In the event of deviating pressure values, switch off the electric motor and check the central greasing system.

Lower oil pressure means that not all of the greasing points are supplied with grease.



Higher oil pressure may cause bursting of a greasing line.

Always refill the grease container in time to avoid air from penetrating into the greasing system. Air in the greasing may cause malfunctions.

PUTTING THE EXCAVATOR OUT OF OPERATION AND RECOMMISSIONING

Putting the excavator out of operation

- Park the excavator on firm and level ground.
- Set the working equipment down on the ground, retracting the piston rods of the hydraulic cylinders as far as possible.
- Set all control element to "0".
- Clean the machine.
- Carry out a visual inspection of the excavator.
- Remove coarse dirt, snow and ice from the fins and fan wheel of the hydraulic oil cooler.
- Protect all bright metal parts (e.g. piston rods) from rust and dirt.
- Remove the batteries; see "Battery storage".
- Secure the machine against unauthorized starting by:
withdrawing the key from the key-switch
setting the battery main switch to OFF
setting the main circuit breaker to OFF
locking the cab door
securing all lockable hatches.
- Cover up all openings

Battery storage

During prolonged machine downtimes, remove the batteries and store in a dry room at an ambient temperature of ca. 20°C / 68°F. Observe the following points with regard to maintenance:

- Clean the batteries.
- Check the acid density and the electrolyte level of the battery every two weeks.
- Recharge the batteries at the latest, when the acid density has dropped to 1.23 kg/dm³.
- Keep the batteries clean and dry on the outside.

Recommissioning

- Remove the covers.
- Degrease / clean all protected components.
- Check track tension (visual inspection)
- Check grease filling in grease container.
- Oil level
 - swing gearboxes
 - pump drive gearboxes
 - travel gearboxes
- Check oil level in hydraulic oil reservoir.
- Check battery acid density and level.
- Install batteries and reconnect.
- Set battery main switch to ON
- Set the main circuit breaker to ON
- Function checks:
 - superstructure holding brake
 - track brake
 - lighting system
 - signalling equipment
- Vent the hydraulic system.

Tanks, pressure vessels and pressure accumulators

Any work on vessels containing or having contained

- combustible or combustion-accelerating substances,
- potentially explosive substances or
- substances susceptible to develop harmful gases, fumes, mists or dusts during welding

may only be carried out under expert supervision and only by experienced personnel especially assigned to such work.

This prescription applies, for instance, to all tanks and reservoirs for hydraulic fluid, engine oil, diesel fuel or lubricating grease.

Welding work on pressure vessels and pressure accumulators is forbidden.

Pressure vessels containing cold-starting fluid (ether) may be installed in or near the engine compartment.

Ether is toxic and highly flammable; the vessels are under pressure. These pressure vessels can explode if exposed to high temperatures (above 49°C / 120°F) or in the event of damage.

Protect the vessels against damage and high temperatures.

Do not perform welding work in the vicinity of these pressure vessels before they have been covered up safely against accidental contact or flying sparks. Have the pressure vessels removed from the machine, if safe protection cannot be ensured.

Inform yourself about the locations in the machine where the pressure accumulators of the hydraulic system are installed. Do not perform welding work in the vicinity of these pressure accumulators before they have been covered up safely against accidental contact or flying sparks. Have the pressure accumulators removed from the machine, if safe protection cannot be ensured.

Slewing rings and articulated joints

The welding current must not flow through ball-bearing or roller-bearing slewings rings, through bolted connections or articulated joints or through hydraulic cylinders.

An electric current flowing through an air gap (e.g. in the bearing or in the articulation) produces a spark which damages the metallic surface.

The welding clamps must therefore always be connected very close to the weld area (max. 2 - 3 m away (6.6-9.8 ft)).

Information relating to the electrical system and to electronic modules

Electric arc welding produces electromagnetic fields, electrostatic charges and voltage spikes which can cause damage to electronic modules. Although the electronic modules of the machine are carefully protected against these influences, it is nevertheless necessary to take additional precautions in order to prevent such damage to the greatest possible extent.

Switch off the electrical system ("ignition OFF").

Open the battery main switch (or disconnect the starter batteries from the machine).

Lay the welding cables as far away from electric lines as possible.

If it is not possible to implement all of the above-mentioned precautions, all connectors must be removed from the electronic modules before beginning any welding work.

Protect withdrawn terminals and connectors from short circuits and soiling. Cover up terminals and connectors with foils or adhesive tape.

Never touch the enclosures of electrical and electronic modules with the welding electrode.

Protect electric lines against the heat emanating from the weld area.

Restore all electrical connections when the welding operations are terminated.

Never connect the ground clamp of the welding cable to the enclosures of electric or electronic modules.

Track drive – Fault table

Fault				Remedial action
No forward travel and no reversing travel				Check P
Maximum travel speed cannot be reached				Adjust E
Insufficient traction power				Replace W
				Top up A
				Reduce S
				Clean R
				1) Contact the CGM HMS GmbH Service
Cause				Chapter ref.
•	•	•	Malfunction of pressure-relief valves	1)
•	•	•	Servo system pump defective	1)
•	•	•	Malfunction of travel valve (pedal)	1)
	•	•	Malfunction of control spool	1)
	•		ECO-power switch in 80%-position	Travelling P
	•		Hydraulic oil temperatur too high (warning lamp lit, PMS fault indicator lamp lit) oil cooler contaminated	Hydraulic oil cooler cleaning P/R



Cat[®]

6060/6060 FS

Electric Drive

Hydraulic Shovel

Specifications

Operating Weight

Shovel

Standard track pads	1 400 mm (4 ft 7 in)
Operating weight	542 300 kg (1,195,550 lb)
Ground Pressure	24.3 N/cm ² (35.1 psi)
Additional track pads available on request	

Backhoe

Standard track pads	1 400 mm (4 ft 7 in)
Operating weight	545 500 kg (1,202,830 lb)
Ground Pressure	24.4 N/cm ² (35.4 psi)
Additional track pads available on request	

Electric Motor

Type	Squirrel cage induction motor
Output	1 800 kW
Voltage	6.6 kV +/- 10% (other on request)
Rated Current I _N	185 A (at 6.6 kV)
Frequency	50 Hz (60 Hz optional)
Revolutions	1 500 min ⁻¹ (1,800 min ⁻¹ optional)
Starting current	450% of I _N (350% of I _N optional)

- Custom-made electric motor with increased gap between rotor and stator to withstand severe mining conditions
- Motor protection relay
- Power limit control by Pump Management System

Medium Voltage Electrical System

Standard supply voltage	6.6 kV +/- 10% (other on request)
Voltage transformer	6 600 V / 400 V
Current transformer	Ratio 200 : 5

- Load breaking switch for 6600 V (emergency stop)
- Voltage monitor for each phase
- Fuse for on-board transformer 6600 V
- Vacuum contactors for motor start stop

Low Voltage Electrical System

System voltage	4 V
Batteries	2 x 170 Ah - 12 V each
in series / parallel installation	170 Ah - 24 V in total

Working spot lights 8 x high brightness Xenon lights

- Emergency stop switch accessible from ground level and in motor module

Hydraulic Shovel—6060/6060 FS (Electric)

Optional Equipment

General

- Export crating
- Finishing as per end user's corporate colors
- Customizing of logos as per customer's specification

Superstructure

- Hydraulic service crane on superstructure with auxiliary engine
- Folding access stairway, stairway angle approx. 45°
- Round container with a standard 200 l grease barrel (instead of 1,000 l grease container)
- Lubricated pinion for greasing of internal gearing of swing ring
- Various cold-weather packages
- 300 m trailing cable
- Power factor correction
- Starting aid transformer (soft-start)

Cab

- Various heating and air-conditioning systems
- Roller blinds at all windows
- Rear windscreen wiper
- Additional instrumentation

Undercarriage

- Track pad width 1 600 mm (5 ft 3 in) or 1 800 mm (5 ft 11 in)
- Automatic lubrication of rollers by central lube system
- Cover plate under carbody (belly plate)

Attachment

- Guards for shovel cylinders of FS-attachment
- Xenon lighting on boom
- Special wear packages

Additional optional equipment available on request

CLICK HERE TO **DOWNLOAD** THE COMPLETE MANUAL

- Thank you very much for reading the preview of the manual.
- You can download the complete manual from: www.heydownloads.com by clicking the link below



- Please note: If there is no response to CLICKING the link, please download this PDF first and then click on it.

CLICK HERE TO **DOWNLOAD** THE COMPLETE MANUAL