

X 325

Excavator

Operation & Maintenance Manual

(S/N 511820001–511821999)

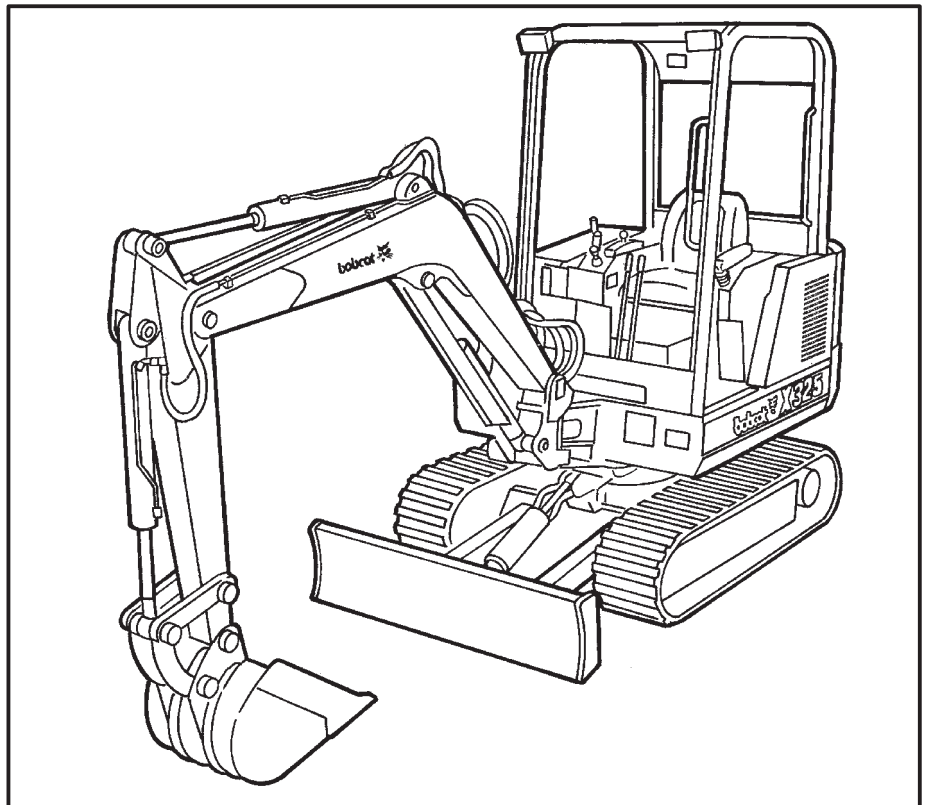

MELROE
INGERSOLL-RAND

6722714 (11-93) Revised (9-97)

Printed in U.S.A.



© Melroe Company 1997

CLICK HERE TO **DOWNLOAD** THE COMPLETE MANUAL

- Thank you very much for reading the preview of the manual.
- You can download the complete manual from: www.heydownloads.com by clicking the link below



- Please note: If there is no response to CLICKING the link, please download this PDF first and then click on it.

CLICK HERE TO **DOWNLOAD** THE COMPLETE MANUAL

SAFETY

SAFETY INSTRUCTIONS	ix, x
FIRE PREVENTION	xi
MACHINE SIGNS (DECALS)	xii, xiii

SAFETY

GETTING ON AND OFF THE MACHINE

Use the grab handles, the tracks and the safety tread to get on and off the machine **[A]**.



Fasten the seat belt snugly. Adjust the seat belt so that the buckle is centered between the hips **[B]**.



Lower the left control console before starting the engine. (See Page 15) **[C]**.



Lift up on the lever (Item 1) **[D]** to release and raise the control console.



BOOM SWING PEDAL

Raise the pedal lock/footrest (Item 1) [A] to operate the boom swing pedal.

Push the pedal (Item 2) [A] on the right side to swing the boom to the right and push the pedal on the left side to swing the boom to the left.

NOTE: The purpose of the boom swing pedal is to offset the boom with respect to the upperstructure.

AUXILIARY OPERATION PEDAL LOCK/FOOTREST

Raise the pedal lock/footrest (Item 3) [A] to operate the attachment operation pedal.

The pedal (Item 4) [A] controls optional equipment when mounted on the arm.

The excavator is equipped with 2-way flow auxiliary lines. Push the pedal (Item 4) [A] to activate the hydraulic function. The right side of the pedal is hydraulic pressure/flow to the female coupler and the left is hydraulic pressure/flow to the male coupler [A] and [C].

To change to one-way flow (return to tank with low back pressure) move the center hose (Item 1) [B] to the fitting (Item 2) [B] and cap the center fitting. The pedal will now supply fluid when pushed to the right side only.

Install the center hose (Item 1) [B] onto the fitting (Item 2) [B] when using the hydraulic breaker.

The female coupler (Item 1) [C] is pressure, the male coupler (Item 2) [C] is return when pedal is pushed to the right.

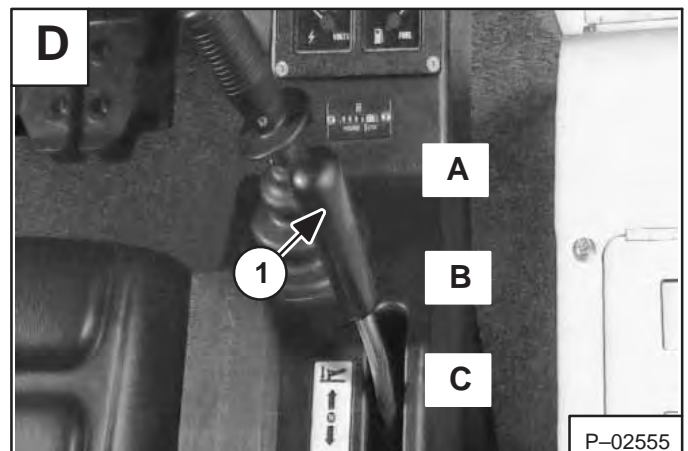
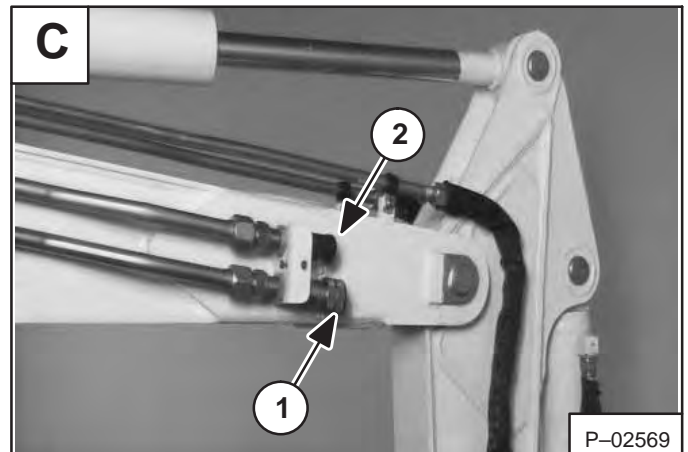
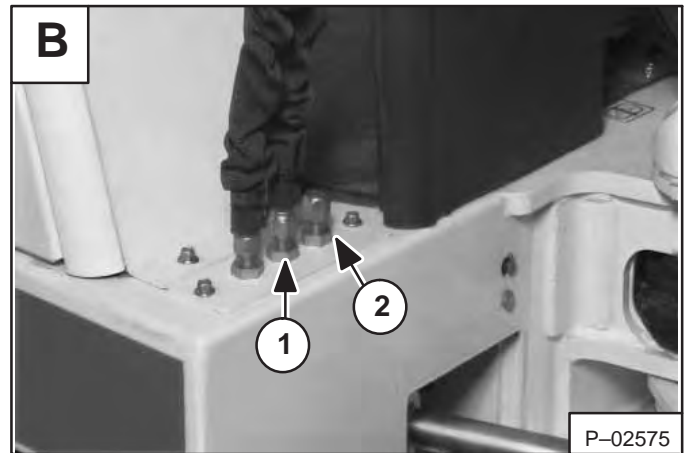
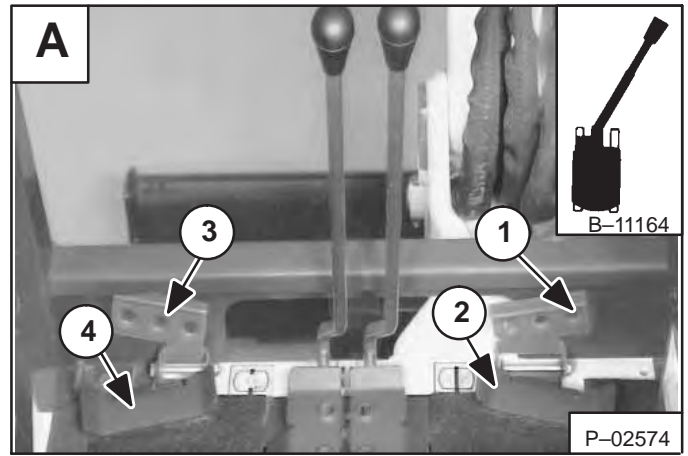

! WARNING

Instructions are necessary before operating or servicing machine. Read Operation & Maintenance Manual, Handbook and signs (decals) on machine. Follow warnings and instructions in the manuals when making repairs, adjustments or servicing. Check for correct function after adjustments, repairs or service. Failure to follow instructions can cause injury or death.

W-2003-0797

BLADE CONTROL LEVER

The lever (Item 1) [D] is used to raise and lower the blade:

Position A – Pushed Forward – Lowers the blade.

Position B – Neutral – Blade is stopped and held in position.

Position C – Pulled Back – Raises the blade.

NOTE: Keep the blade lowered when digging to stabilize machine.

CAB OPTION

Opening the Front Window

Move the four window latch pins inward and place them in the unlatched position **[A]**.



Grab both window handles and pull the top of the window inward **[B]**.

When the top of the window moves inward, lift up on the window handles and the window will move up and will pivot inward, over the operators head.

When the window is over the operators head, lift the bottom of the window upward. The top edge of the window will engage the pocket at the top rear of the cab.



Hold the bottom of the window up and move the two bottom window latch pins outward. Make sure that the pins are secured to the open window latch points **[C]**.

Closing the Front Window

Hold the bottom of the window up and move the two window latch pins inward and place them in the unlatched position **[C]**.

Grab both window handles and pull the bottom of the window downward **[B]**.

When the window is in the down and vertical position, push outward at each corner latch point and move the latch pins into the locked position **[A]**.



COOLING SYSTEM

Coolant Level

When the engine is cool, the coolant level in the recovery tank (Item 1) [A] must be half full.

If the coolant level is low, add premixed coolant (50% water and 50% ethylene glycol) to the recovery tank.

Coolant Replacement

WARNING

Do not remove radiator cap when the engine is hot. You can be seriously burned.

W-2070-1285

Turn the upperstructure so there is access to the engine and radiator from between the tracks. Stop the engine.

Loosen and remove the radiator cap (Item 1) [B].

Open the radiator drain valve (Item 1) [C] at bottom of radiator.

Drain all the coolant from the system

NOTE: Also remove all coolant from the coolant recovery tank (Item 1) [A].

When all the coolant is removed, close the drain valve.

Premix coolant in a separate container.

Ethylene Glycol

Add premixed coolant; 50% water and 50% ethylene glycol to the recovery tank if the coolant level is low.

Propylene Glycol

Add premixed coolant; 43% water and 57% propylene glycol to the recovery tank if the coolant level is low.

One gallon and one pint of propylene glycol mixed with one gallon of water is the correct mixture of coolant to provide a -34°F (-37°C) freeze protection.

NOTE: Do Not mix ethylene glycol and propylene glycol in the same cooling system.

Use a refractometer to check the condition of propylene glycol in your cooling system.

Fill the radiator with the premixed coolant until it is full. Add coolant to the recovery tank until it is half full.

Run the engine at idle speed for about 5 – 10 minutes to remove the air from the cooling system (leave the radiator cap off during this operation).

Stop the engine. Check the coolant level and add as needed to bring it up to the radiator filler neck. Install the radiator cap and tighten.

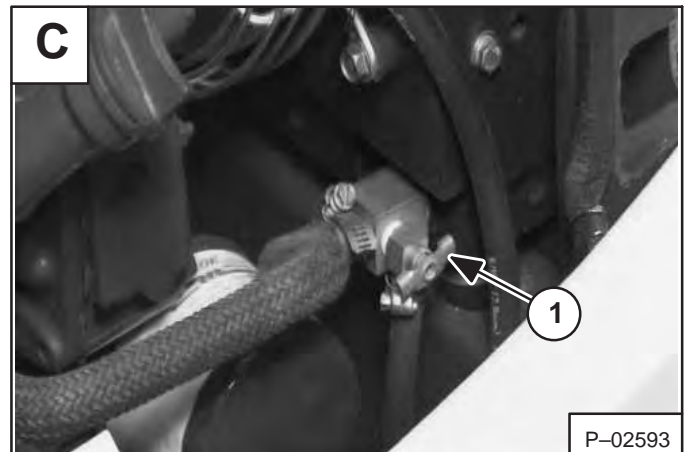
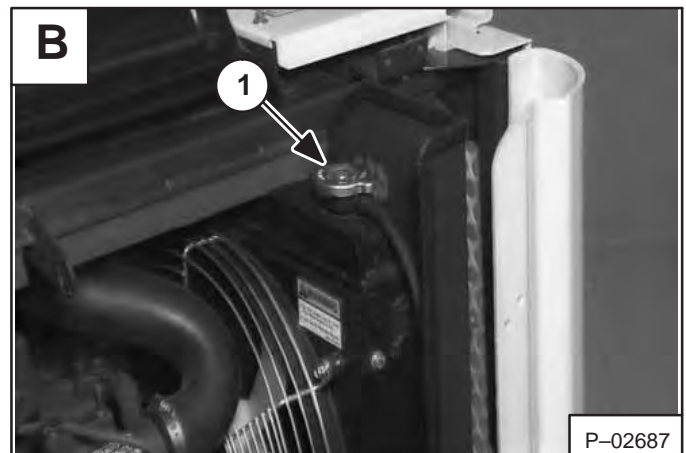
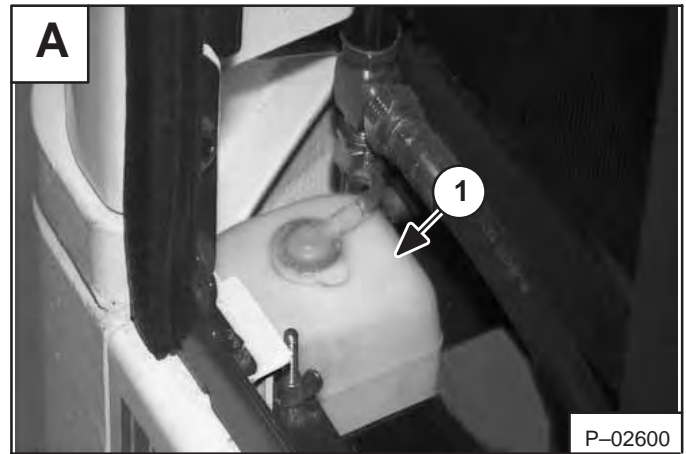

FINAL DRIVE CASE

Checking Oil Level

Put the machine on a flat level surface with the plugs positioned as shown in figure [A].

Remove the top plug (Item 1) [A]. The oil level should be at the bottom edge of the plug hole.

Add gear lube 90W through the hole if the oil level is below the hole. (See Fuel, Coolant and Lubricant Chart, Page 52.)

Install and tighten the plug.

Repeat the procedure for the other side.

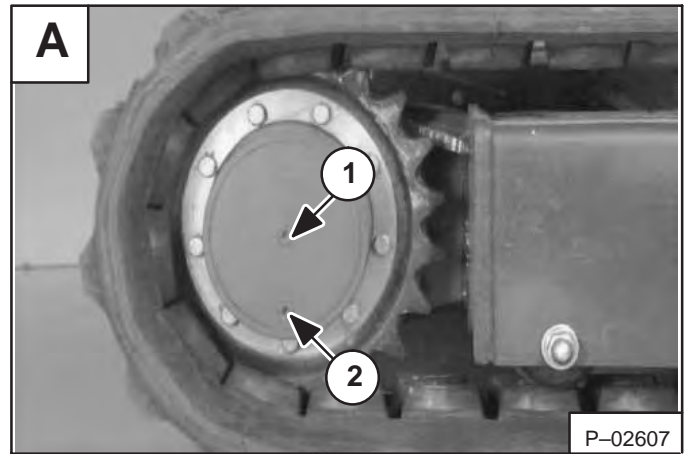

Draining Final Drive Case

See the *SERVICE SCHEDULE* Page 27 for the correct service interval.

Put the machine on flat level surface with the plugs positioned as shown in figure [A].

Remove the bottom plug (Item 2) [A] and top plug (Item 1) [A].

After all the gear lube is removed, install and tighten the bottom plug (Item 2) [A].

Add .55 quarts (0,5 L) of gear lube 90W to the top plug hole (or until gear lube level is at the bottom edge of the plug hole). Install the plug.

Repeat the procedure for the other side.

BUCKET SPECIFICATIONS

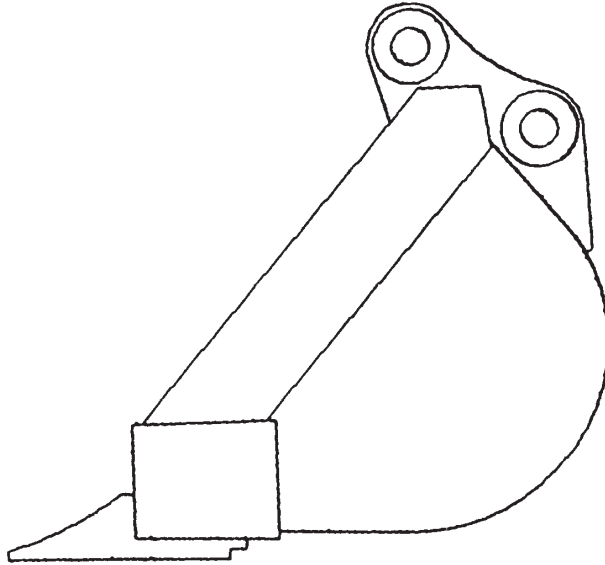

MC-1411

Bucket Size	Capacity SAE Heaped	Shipping Weight
12 in. (305 mm)	1.02 cu. ft. (0,029 cu. m.)	106.9 lbs. (48,5 kg)
16 in. (406 mm)	1.61 cu. ft. (0,046 cu. m.)	123.0 lbs. (55,8 kg)
20 in. (508 mm)	2.36 cu. ft. (0,067 cu. m.)	135.7 lbs. (61,6 kg)
24 in. (609 mm)	2.88 cu. ft. (0,082 cu. m.)	157.8 lbs. (68,9 kg)

FOREWORD

FOREWORD

This manual gives the owner/operator necessary operating, and preventive maintenance instructions for the Bobcat Hydraulic Excavator.

Read this manual completely and know the Bobcat Hydraulic Excavator before operating and servicing it. All references to *left* or *right* on the excavator are given in relation to the operator's left or right hand while in the operator's seat.

For further information, see your Bobcat Hydraulic Excavator dealer. Parts Manuals, Service Manuals and extra Operation & Maintenance Manuals are available. The Compact Excavator Operator Training Course is also available.

SERIAL NUMBER LOCATION	v
DELIVERY REPORT	v
HYDRAULIC EXCAVATOR IDENTIFICATION	vi

MACHINE SIGNS (DECALS) (Cont'd)

Follow the instructions on all the Safety Signs (Decals) that are on the excavator. Replace any damaged safety signs and be sure they are in the correct locations. Safety signs are available from your Bobcat Excavator dealer.

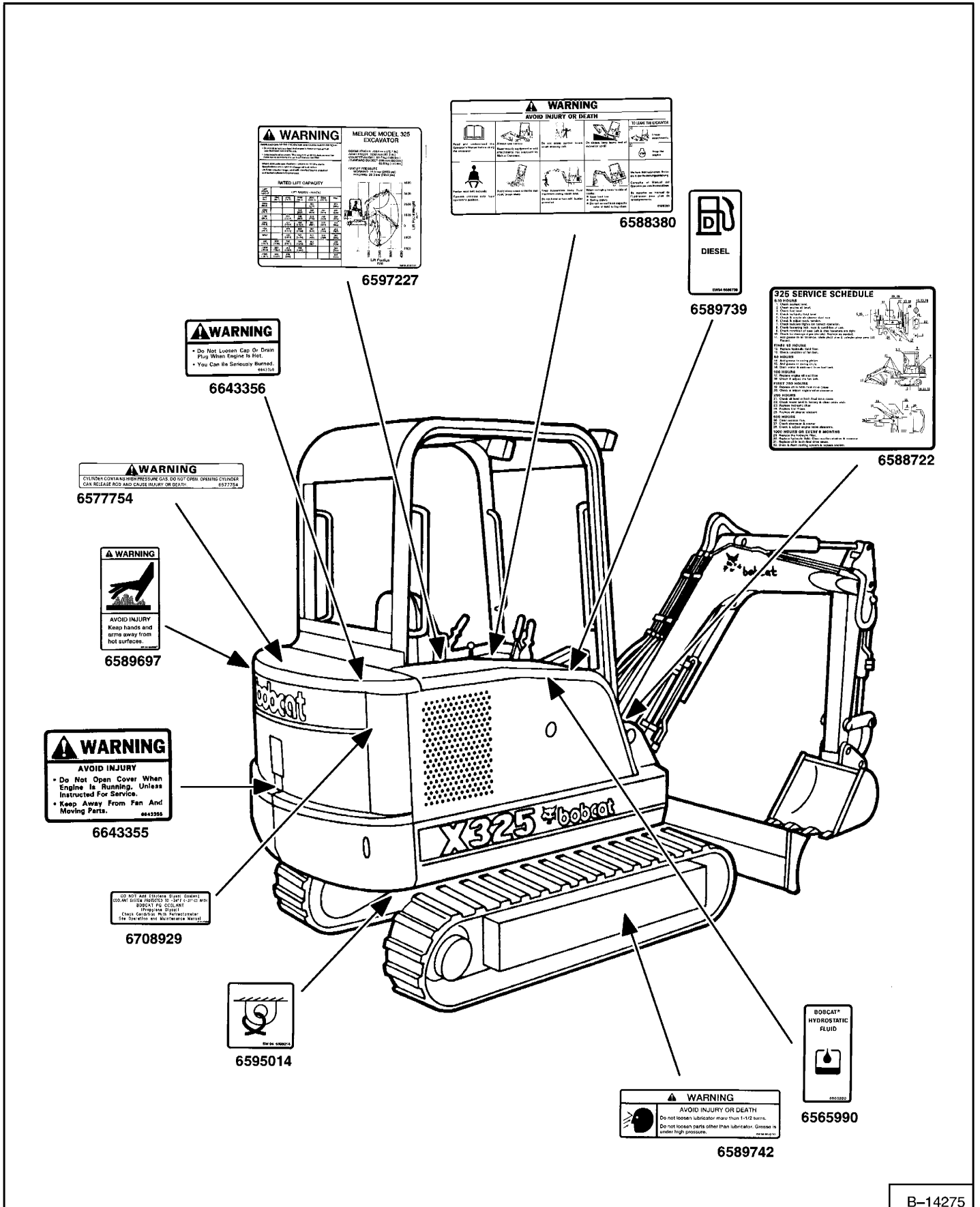

CONTROL LEVERS

The work equipment is operated by using the left and right control levers (joysticks) [A] & [B].

Operation of Left Control Lever (ISO)

Arm and Swing (Decal P/N 6589741)

The left lever is used to operate the arm and swing the upperstructure [A]:

1. Arm Out
2. Arm Out and Swing Right
3. Swing Right
4. Arm In and Swing Right
5. Arm In
6. Arm In and Swing Left
7. Swing Left
8. Arm Out and Swing Left

IMPORTANT

Before swinging the upperstructure, make sure the swing lock is disengaged.

I-2051-0189

Operation of Right Control Lever (ISO)

Boom and Bucket (Decal P/N 6589740)

The right lever is used to operate the boom and bucket [B]:

1. Boom Lower
2. Boom Lower and Bucket Dump
3. Bucket Dump
4. Boom Raise and Bucket Dump
5. Boom Raise
6. Boom Raise and Bucket Curl
7. Bucket Curl
8. Boom Lower and Bucket Curl

! WARNING

AVOID INJURY OR DEATH

Before leaving the machine:

- Lower the work equipment to the ground.
- Lower the blade to the ground.
- Stop the engine & remove the key.

W-2196-0595

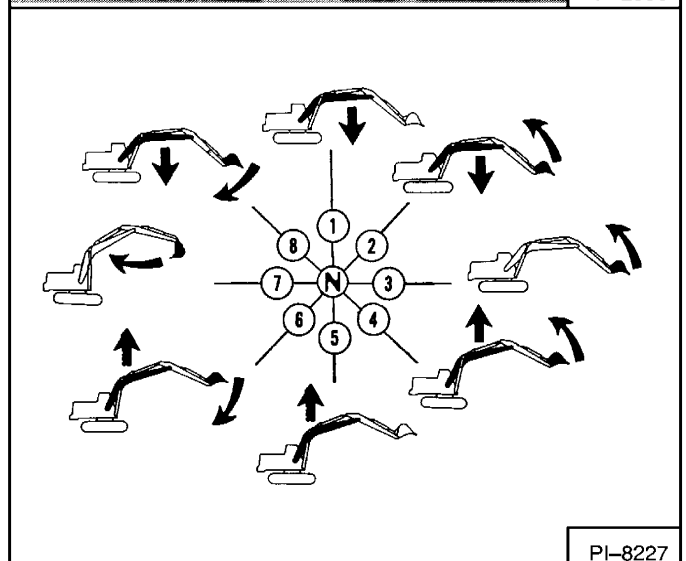
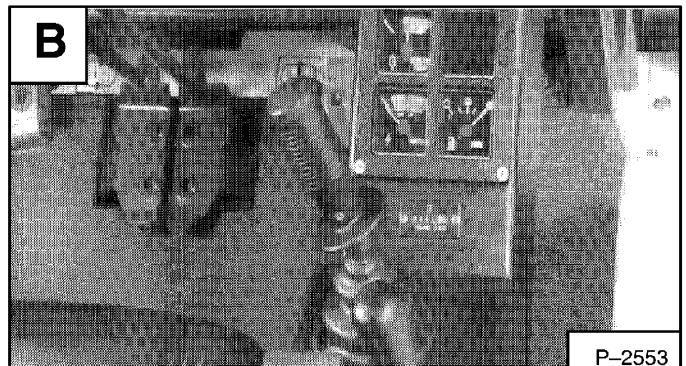
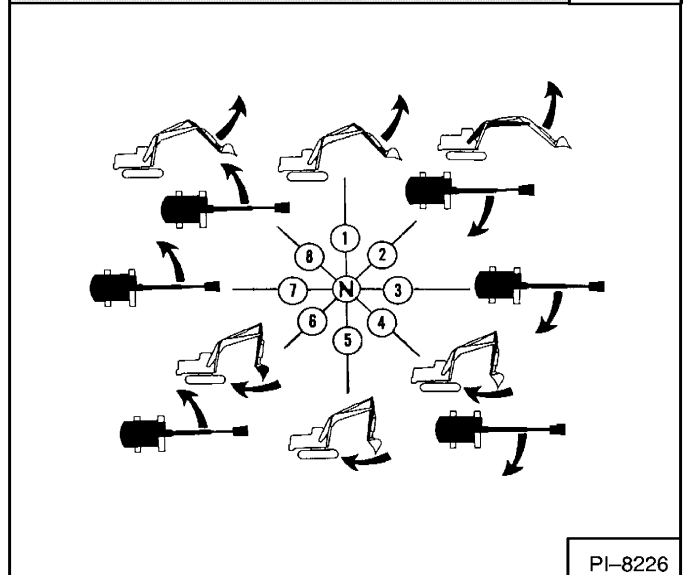
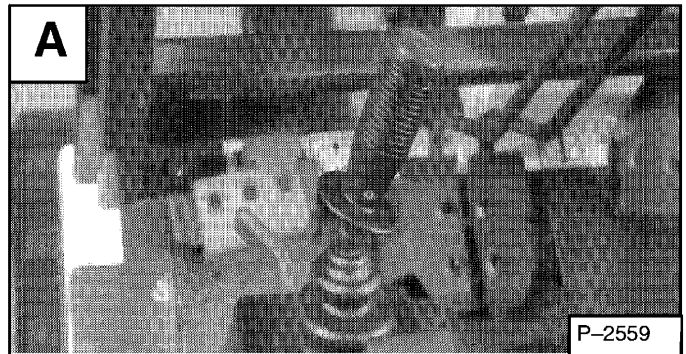

OPERATING PROCEDURES (Cont'd)

Operating in Water

Mud and water should be removed from the machine before parking. If possible, park the machine on boards or concrete to prevent the track or undercarriage from freezing to the ground and preventing machine movement.

Do not operate or immerse the Excavator in water higher than the bottom of the swing circle **[A]**.

Properly grease the Excavator when it has been operated or immersed in water for a period of time.

Water must be removed from the cylinder rods. If water freezes to the cylinder rod, the cylinder seals can be damaged when the rod is retracted.

PARKING THE HYDRAULIC EXCAVATOR

Stop the machine on level ground. Lower the work equipment and the blade to the ground.

Run the engine at idle speed for about 5 minutes to allow it to cool.

Push the speed control lever fully to the rear **[B]**.

Turn the key switch to the "OFF" position (Inset) **[B]**.

Disconnect the seat belt. Remove the key from the switch to prevent operation of machine by unauthorized personnel.

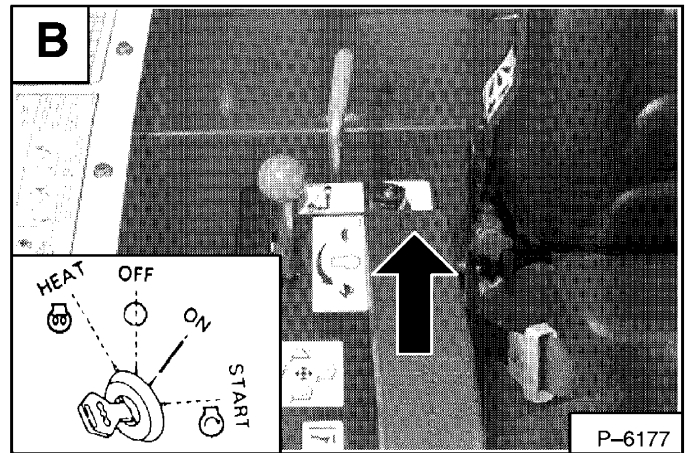
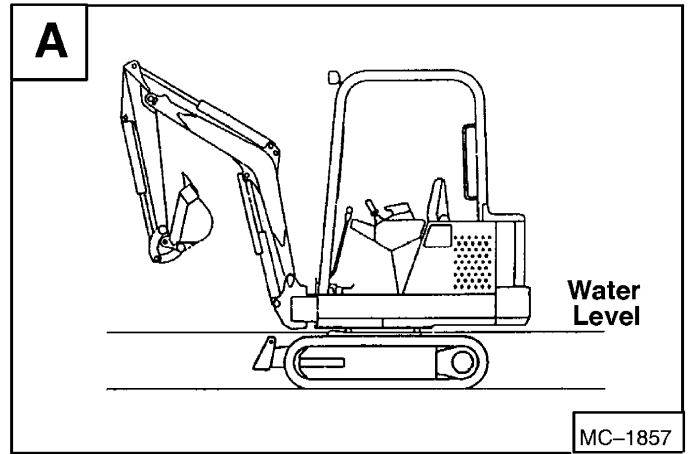

ENGINE COVER

WARNING

AVOID INJURY

Never service or adjust the machine when the engine is running unless instructed to do so in this manual.

W-2012-0290

Keep the engine cover closed when operating the machine.

W-2141-0189

Open the engine cover to service the engine. Pull on the latch and lift the engine cover up until it is fully raised [A].

AIR CLEANER SERVICE

See the Service Schedule (Page 26) for the correct service interval.

Replace the filter element when the red ring shows in the window of the condition indicator (Item 1) [B].

NOTE: Push the button on the condition indicator, start the engine and run the engine at high idle. If the red ring does not show, do not replace the filter element.

Service the air cleaner as follows:

Remove the cover wing nut (Item 1) [C].

Remove the cover (Item 2) [C].

Remove the wing nut (Item 1) at the primary filter element [D].

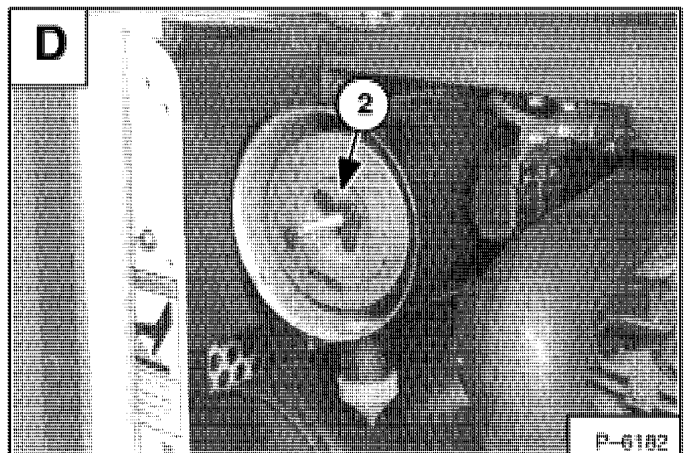
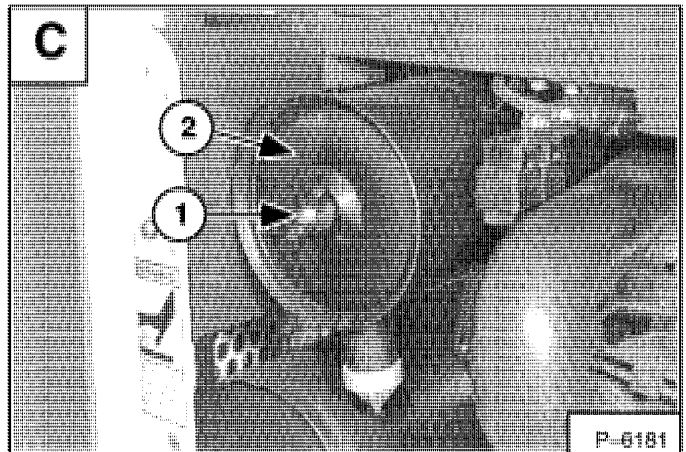
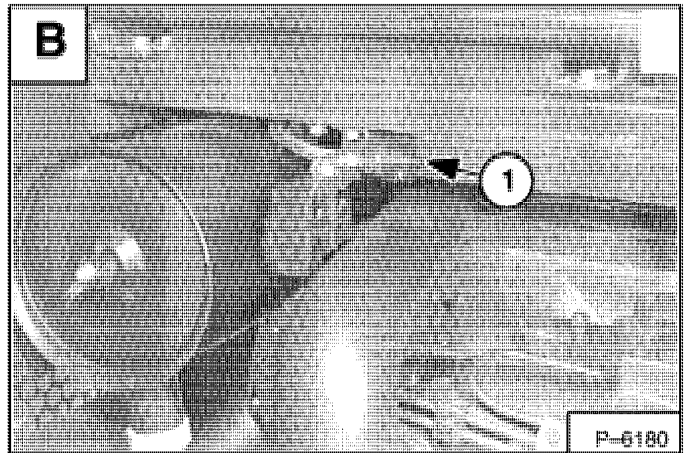
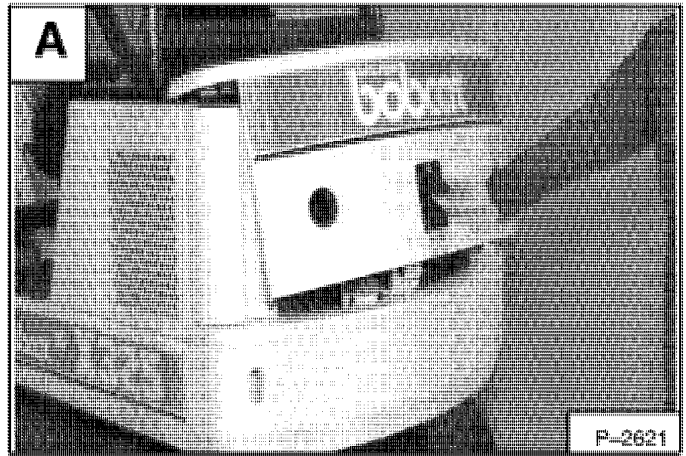

HYDRAULIC SYSTEM

Checking and Adding Fluid

To check and add hydraulic fluid to the reservoir, use the following procedure:

Put the machine on a flat level surface.

Retract the arm and bucket cylinders, put the bucket on the ground and raise the blade. Stop the engine.

Check the hydraulic fluid level, it must be visible in the sight gauge (Item 1) **[A]** located on the side of the hydraulic reservoir.

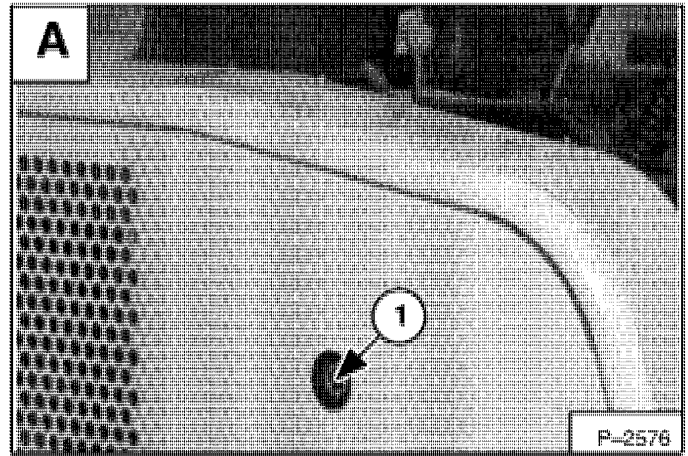

If the fluid level is not correct, open the hydraulic tank access door **[B]**.

Remove oil fill cap **[B]**.

Check the condition of the fill strainer **[C]**. The screen must be installed in fill neck when adding oil.

Add the correct fluid to the reservoir until it is visible in the sight gauge (See Fuel, Coolant and Lubricants Chart, Page 54).

Install the reservoir cap and close and lock the access door.

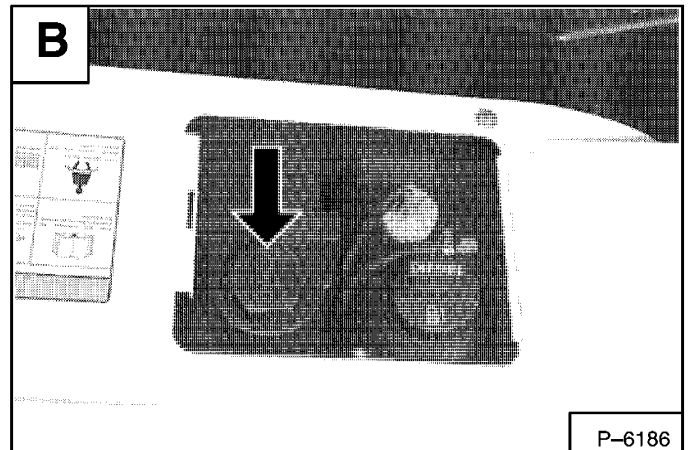

Return Line Filter Service

See the Service Schedule (Page 28) for the correct service interval.

Open the right side cover (See Page 36).

Remove the filter cartridge (Item 1) **[D]**.

Disassemble the cartridge and clean thoroughly.

Install the filter cartridge.

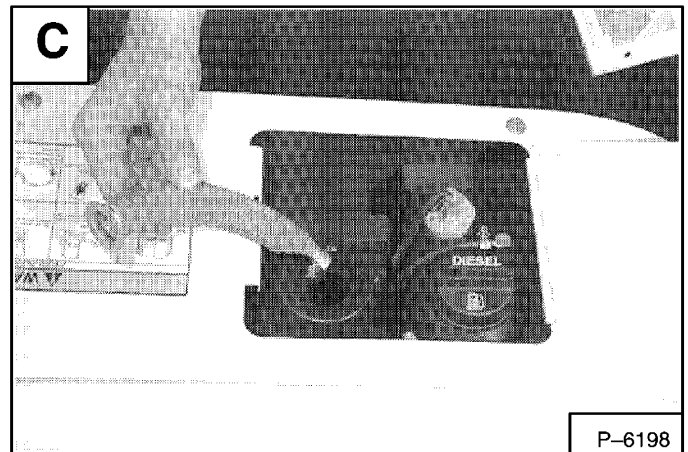

Replacement of the Hydraulic Filter

See the Service Schedule (Page 28) for the correct service interval.

Open the right side cover (See Page 36).

Use a filter wrench and remove the filter element (Item 2) **[D]**.

Clean the housing where the filter gasket makes contact.

Put clean hydraulic fluid on the gasket. Install the new filter element and hand tighten only.

Start the engine. Run the machine through the hydraulic functions. Stop the engine. Check the fluid level at the reservoir and add as needed. Check around the filter for leaks.

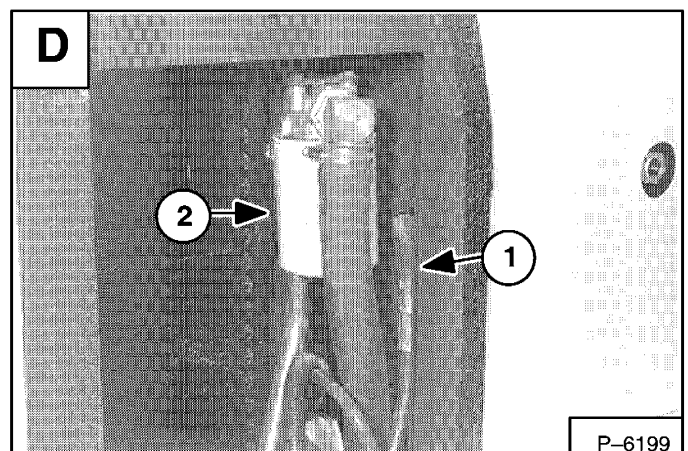

SPECIFICATIONS

ADDITIONAL PUBLICATIONS	56
BUCKET SPECIFICATIONS	55
COOLANT MIXTURE	54
FUEL, COOLANT AND LUBRICANT CHART	54
HYDRAULIC EXCAVATOR SPECIFICATIONS	51
Brakes	53
Capacities	53
Cylinder Cycle Times	53
Digging Force	53
Drive System	53
Engine	52
Hydraulic Cylinders	53
Hydraulic System	53
Lifting Capacity	52
Machine Dimensions	51
Operation & Performance	52
Swing System	53
Tracks	53
Undercarriage	53
ENGINE OIL SPECIFICATIONS	54
Description	54

SPECIFICATIONS

X 325

Excavator

Operation & Maintenance Manual

(S/N 514013001 & Above)

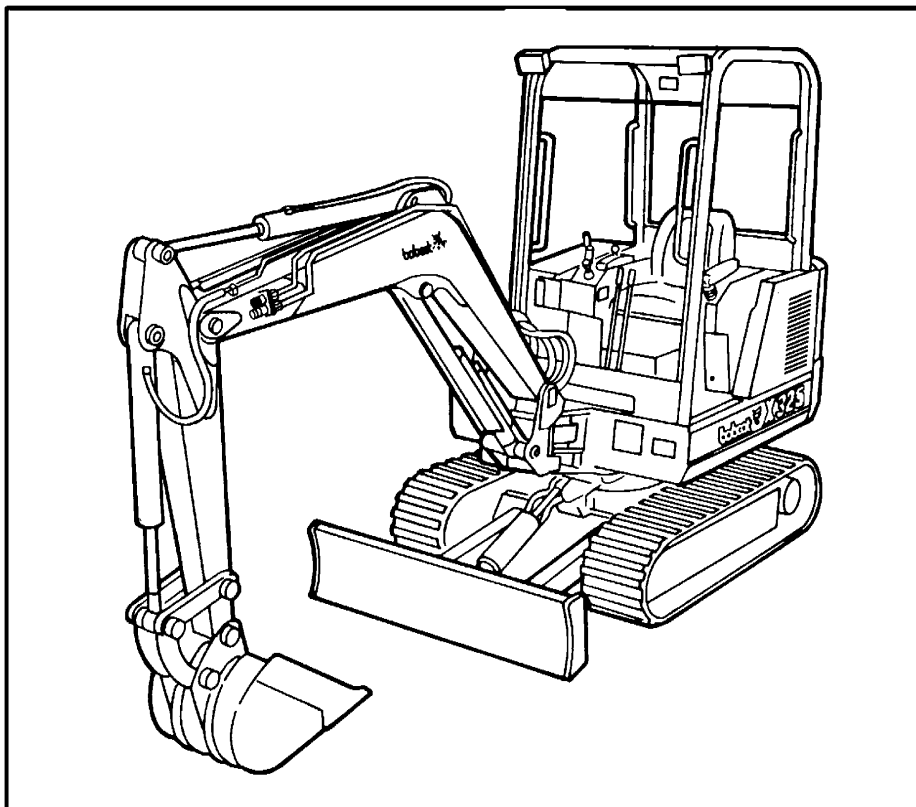

MELROE
INGERSOLL-RAND

6724546(3-97) Revised (5-97)

Printed in U.S.A.



© Melroe Company 1997

SAFETY

SAFETY INSTRUCTIONS	ix, x
FIRE PREVENTION	xi
MACHINE SIGNS (DECALS)	xii, xiii

SAFETY

INSTRUMENT PANEL

The instrument panel has the following instruments [A]:

1. **PREHEAT INDICATOR LIGHT** – When turning the key switch to the PREHEAT position, the light comes ON, showing the glow plugs are heating.
2. **ENGINE TEMPERATURE LIGHT** – (Overheat indicator) When the engine coolant temperature exceeds the allowable temperature range, the light comes ON and the audible alarm sounds. STOP the engine.
3. **LOW FUEL INDICATOR LIGHT** – When fuel level is low (2.5 gals. [9,5 L.]), the light comes ON. Add fuel.
4. **FUEL GAUGE** – Shows the amount of the fuel in the tank.
5. **HOURMETER** – Records total operating hours. If the ignition key is left in the run position, with the engine OFF, the audible alarm will sound.
6. **CHARGING GAUGE** – Shows battery charge rate.
7. **ENGINE TEMPERATURE GAUGE** – Shows engine coolant temperature. Audible alarm sounds when temperature reaches 230°F. (110°C.).
8. **ENGINE OIL LIGHT** – When the engine oil pressure is low, the light comes ON and audible alarm sounds. STOP the engine.

NOTE: To check oil pressure and water temperature lights, turn the key to the ON position. Lights should stay on for 10 seconds. Allow five seconds cooling time and try again.

KEY SWITCH

The key switch has the following functions [B]:

- A. Key switch is OFF, and the engine stops.
- B. PREHEAT position – Hold switch in this position to activate the glow plugs for starting in cold weather. (See Decal (Item 1) [B] for glow plugs heating times and Page 17.)
- C. START the engine.
- D. ON (run) position – When the engine is running release the key and this position is obtained automatically. The fuel gauge back light is illuminated when the key switch is in the on (run) position.

NOTE: Always turn key switch and all accessories to OFF position after the engine is stopped or battery will discharge. Audible alarm will sound if the key is in the ON position with the engine stopped.

See Pages 16 and 17 for the starting procedure.

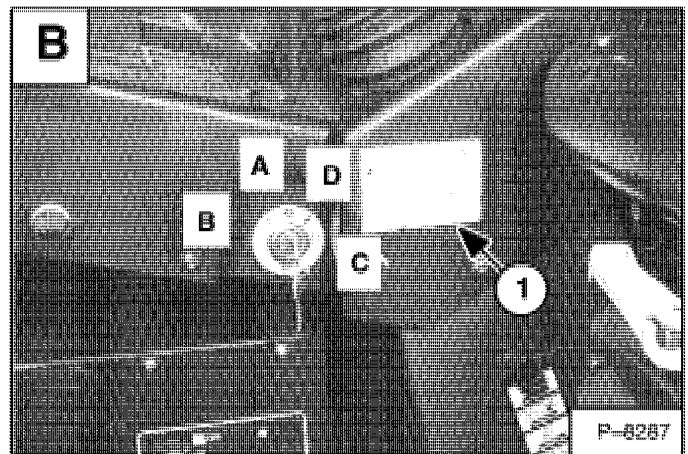
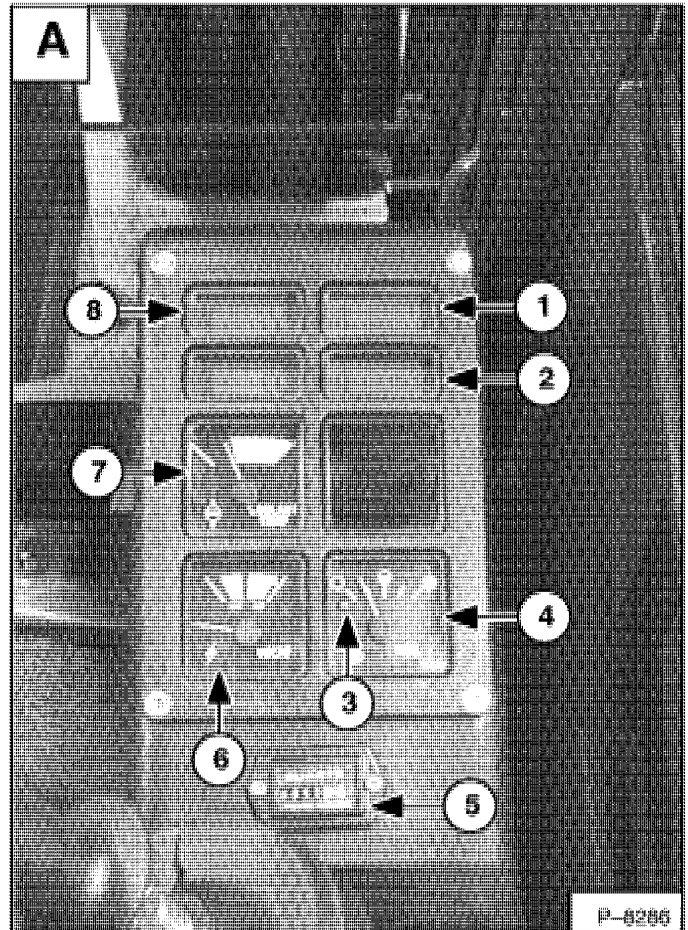

CONTROL LEVERS (JOYSTICKS) (Cont'd)

The work equipment is operated by using the right and left control levers (joysticks) [A] & [B].

Operation Of Left Control Lever (Standard)

Boom and Swing (Decal P/N 6589842).

The left lever is used to operate the boom and swing the upperstructure [A]:

1. Boom lower.
2. Boom lower and swing right.
3. Swing right.
4. Boom raise and swing right.
5. Boom raise.
6. Boom raise and swing left.
7. Swing left.
8. Boom lower and swing left.

IMPORTANT

Before swinging the upperstructure, make sure the swing lock is disengaged.

I-2051-0189

Operation Of Right Control Lever (Standard)

Arm and Bucket (Decal P/N 6589843).

The right lever is used to operate the arm and bucket [B].

1. Arm out.
2. Arm out and bucket dump.
3. Bucket dump.
4. Arm in and bucket dump.
5. Arm in.
6. Arm in and bucket curl.
7. Bucket curl.
8. Arm out and bucket curl.

! WARNING

AVOID INJURY OR DEATH
Before leaving the machine:

- Lower the work equipment to the ground.
- Lower the blade to the ground.
- Stop the engine & remove the key.

W-2196-0595

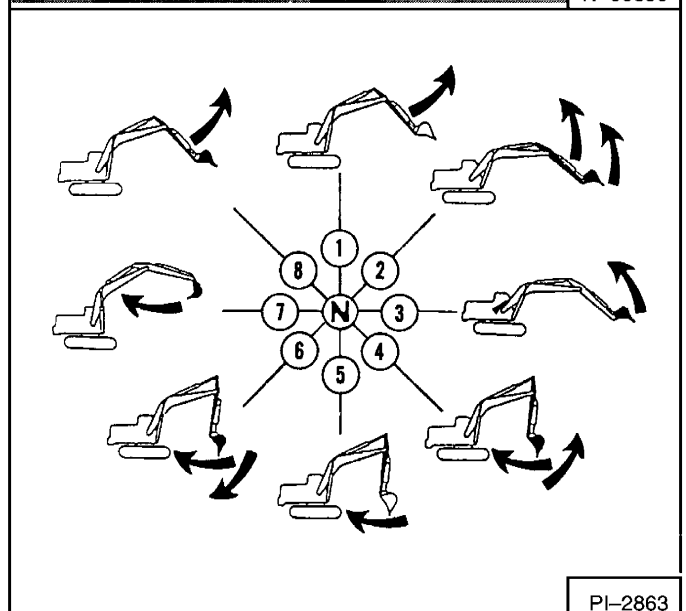
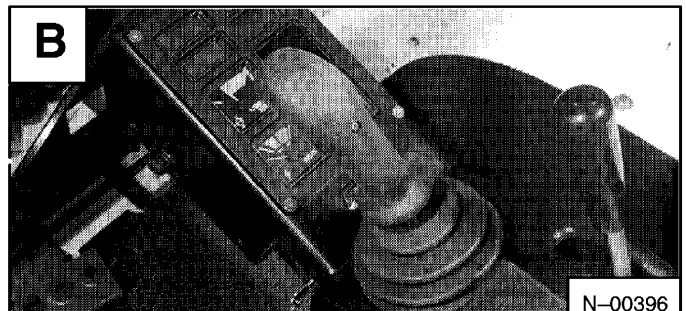
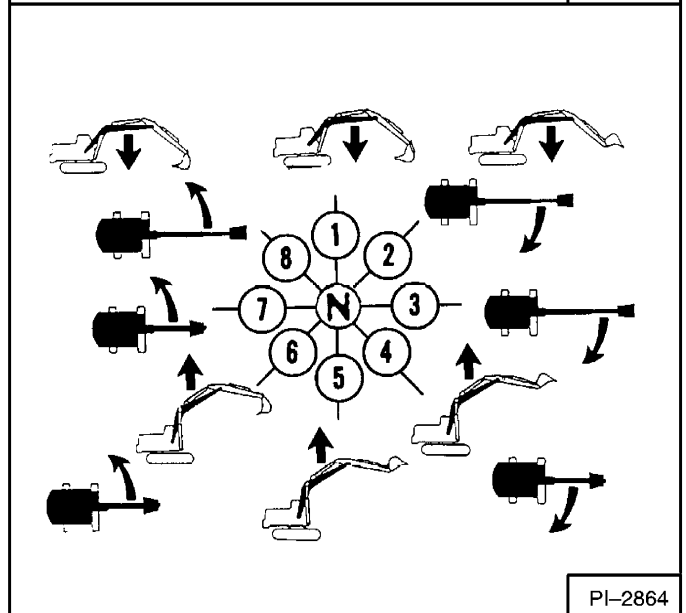
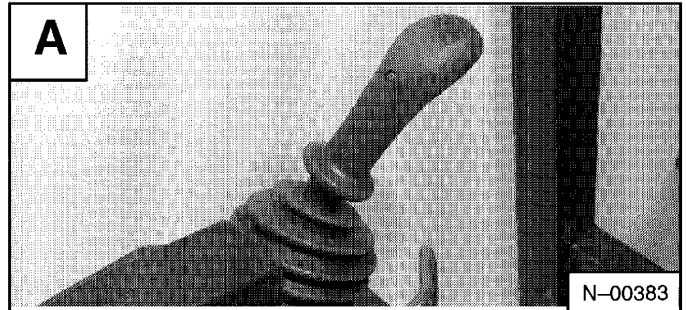

LIFTING THE HYDRAULIC EXCAVATOR

Fully extend the cylinders of the bucket, arm & boom.

Put the work equipment control levers in neutral and engage the swing locking lever.

WARNING

AVOID INJURY OR DEATH

- Use a lifting fixture with sufficient capacity for the weight of the excavator plus any added attachments.
- Maintain center of gravity and balance when lifting.
- Do not swing boom or upperstructure. Engage the swing locking lever.
- Never lift with operator on machine.

W-2202-0595

Secure the lifting fixture sling to the lifting holes at the left and right side at the rear of the frame and the lift eye on the boom [A] & [B].

Install spreader bar above the cab to prevent lifting fixture from rubbing on ROPS or the rear engine cover.

LIFTING A LOAD

Do not exceed rated load capacity. (See *Lifting Decal*, Page 52.)

Use chain assembly (P/N 6665374) for lifting.

To install the chain assembly:

Extend bucket cylinder fully. Stop the engine.

Wrap chain assembly around the arm or the bucket mounting plate and fasten with the hook [C].

Attach the secondary lift system (i.e. cables, chains or slings) to the loop (Item 1) [C] of the chain assembly.

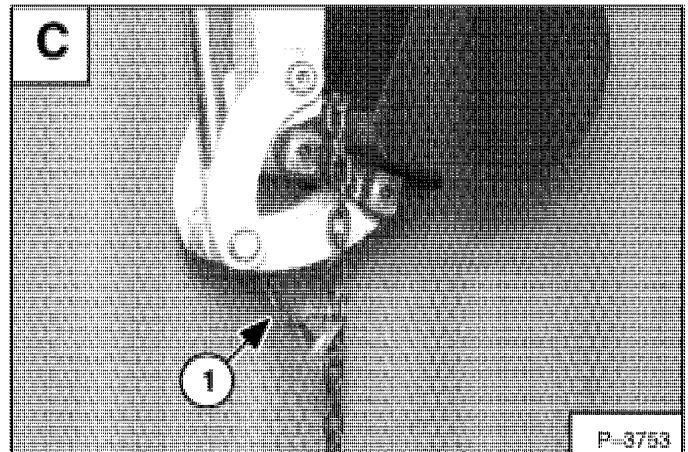
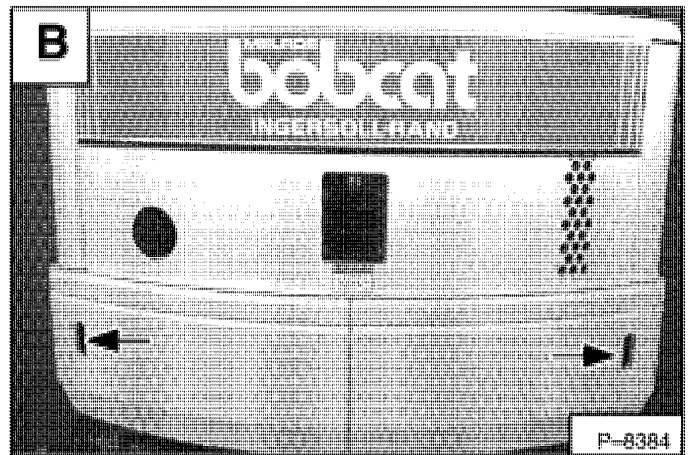
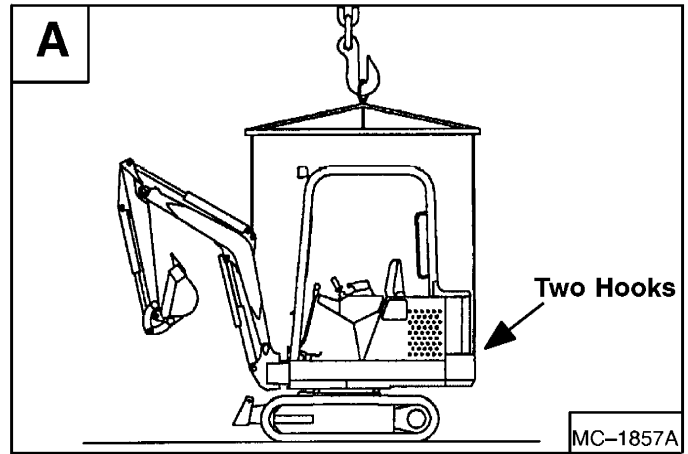

COOLING SYSTEM

Coolant Level

When the engine is cool, the coolant level in the recovery tank (Item 1) [A] must be half full.

If the coolant level is low, add premixed coolant to the recovery tank (See type of coolant information below).

Coolant Replacement

! WARNING

Do not remove radiator cap when the engine is hot. You can be seriously burned.

W-2070-1285

Turn the upperstructure so there is access to the engine and radiator from between the tracks. Stop the engine.

When the engine is cool, loosen and remove the radiator cap (Item 1) [B].

Open the radiator drain valve (Item 1) [C] at bottom of radiator. Drain the coolant into a container.

Open the engine block drain valve (Item 1) [D] and drain the coolant into a container.

After all the coolant is removed, close both drain valves.

NOTE: Remove all coolant from the coolant recovery tank (Item 1) [A].

Propylene Glycol (Factory Installed)

Add premixed coolant; 47% water and 53% propylene glycol to the recovery tank if the coolant level is low.

One gallon and one pint of propylene glycol mixed with one gallon of water is the correct mixture of coolant to provide a -34°F (-37°C) freeze protection.

Use a refractometer to check the condition of propylene glycol in your cooling system.

Fill the radiator with the premixed coolant until it is full. Add coolant to the recovery tank until it is half full.

Run the engine at idle speed for about 5–10 minutes to remove the air from the cooling system (leave the radiator cap off during this operation).

Stop the engine. Check the coolant level and add as needed to bring it up to the radiator filler neck. Install the radiator cap and tighten.

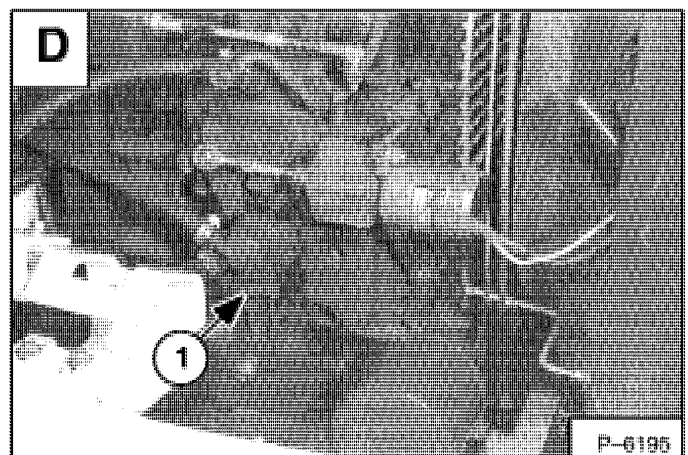
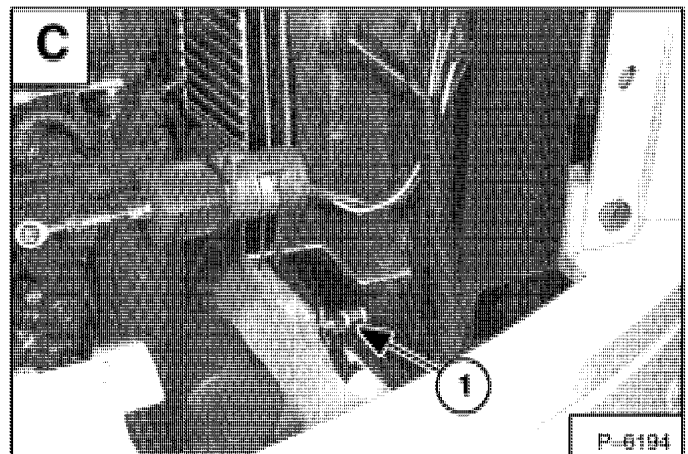
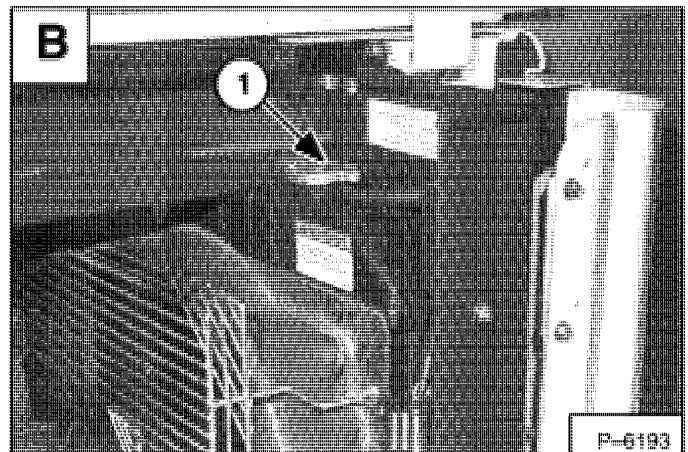
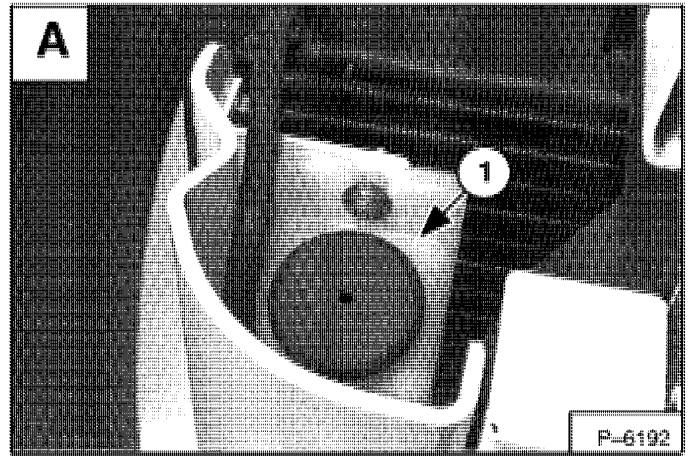

FINAL DRIVE CASE

Checking Oil Level

Put the machine on a level surface with the plugs positioned as shown in figure [A].

Remove the plug (Item 1) [A]. The oil level should be at the bottom edge of the plug hole.

If the oil level is below the hole, remove the plug (Item 2) [A].

Add 90W gear lube through the top hole (Item 2) [A] until the oil level is at the bottom of the hole (Item 1) [A]. (See *FUEL, COOLANT AND LUBRICANTS CHART* Page 62.)

Install and tighten both plugs.

Repeat the procedure for the other side.

Draining Final Drive Case

See the *SERVICE SCHEDULE* Page 27 for the correct service interval.

Put the machine on a level surface with the plugs positioned as shown in figure [A].

Remove the bottom plug (Item 1) [A] and top plug (Item 2) [B].

After all the gear lube is removed, position the drive correct as shown in figure [A].

Add 0.74 quarts (0,7 L) of gear lube 90W to the top plug hole (Item 2) [A] (or until gear lube level is at the bottom edge of the plug hole) (Item 1) [A]. Install and tighten both plugs.

Repeat the procedure for the other side.

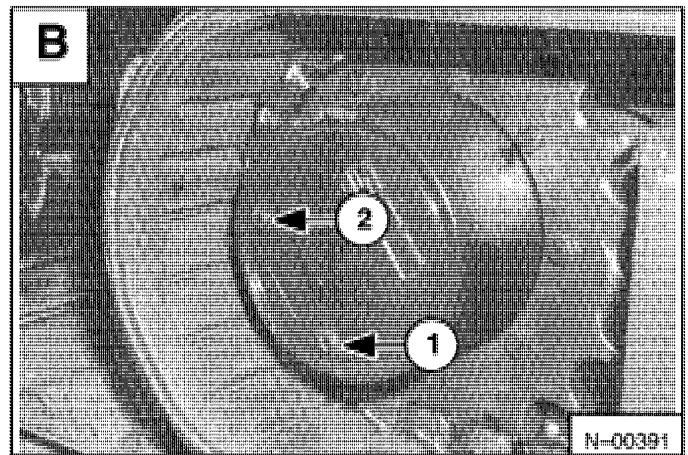
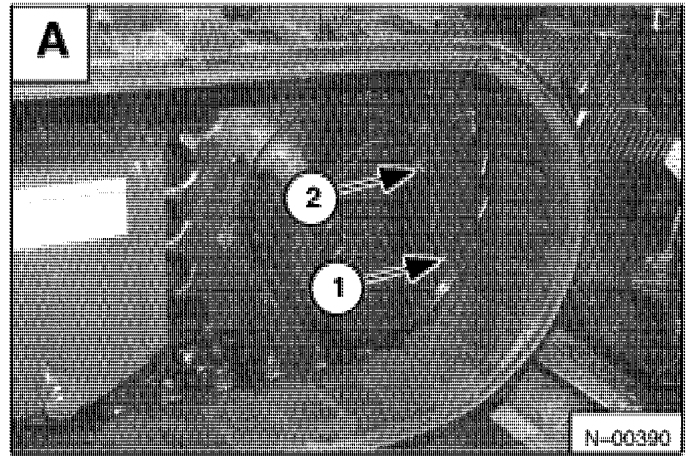

325 SERVICE SCHEDULE

(See operator's Manual for Instructions & Specifications)

EVERY 8-10 HOURS

1. Check engine coolant level.
2. Check engine oil level.
3. Check hydraulic fluid level.
4. Check air cleaner condition indicator.
5. Check & adjust track tension.
6. Check indicator lights for correct operation.
7. Check cab / canopy condition & mounting hardware.
8. Check seat belt condition & mounting hardware.
9. Check for damaged signs (decals) - Replace as needed.
10. Grease all machinery pivot points (23 places).

EVERY 50 HOURS

11. Grease swing pinion & swing circle (3 places).
12. Drain water & sediment from fuel tank & fuel filter.
13. Replace engine oil and filter (at first 50 hours).
14. Check condition of fan belt (at first 50 hours).

EVERY 100 HOURS

15. Check & adjust the fan belt if required.
16. Spark Arrestor Muffler - Clean spark chamber.
17. Replace hydraulic filter (at first 100 hours).
18. Replace oil in both final drive cases (at first 100 hours).
19. Replace case drain hydraulic filter (at first 100 hours).

EVERY 250 HOURS

20. Replace diesel fuel filter.
21. Replace engine oil and filter.
22. Check oil level in both final drive cases.
23. Check battery condition - Clean cable ends.

EVERY 500 HOURS

24. Clean radiator fins.
25. Replace hydraulic filter.
26. Check alternator & starter connections.
27. Check & adjust engine valve clearance.
28. Replace case drain hydraulic filter.

EVERY 1000 HOURS or EVERY 6 MONTHS

29. Replace oil in both final drive cases.
30. Drain & flush cooling system - Replace coolant.
31. Replace hydraulic fluid & filter - Clean reservoir.

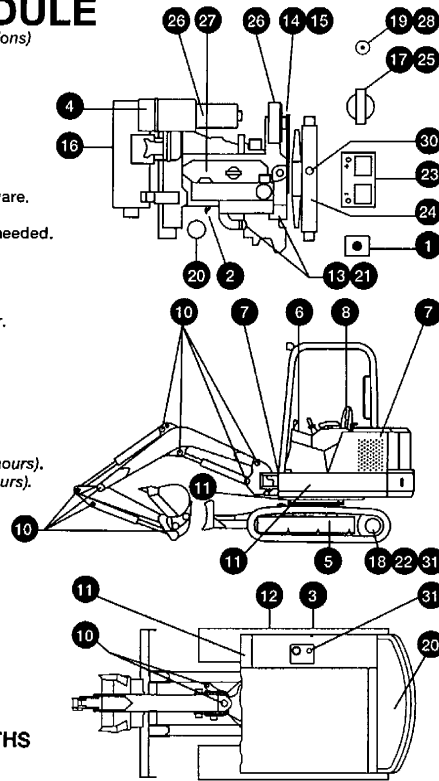

SW 96 6628905

PROGRAMA DE SERVICIO 325 (SPANISH)

(Ver el Manual del operador para instrucciones y especificaciones)

8-10 HORAS

1. Verificar el nivel del refrigerante del motor.
2. Verificar el nivel de aceite del motor.
3. Verificar el nivel del fluido hidráulico.
4. Verificar la condición del indicador del depurador de aire.
5. Verificar y ajustar la tensión de la oruga.
6. Verificar la correcta operación de las luces indicadoras.
7. Verificar la condición de la cabina/cubierta y de la ferretería de montaje.
8. Verificar la condición del cinturón de seguridad y la ferretería de montaje.
9. Verificar si hay daños en las señales (calcomanías). Reemplazar según sea necesario.
10. Engrasar todos los puntos de pivote de la maquinaria (23 lugares).

CADA 50 HORAS

11. Engrasar el piñon de giro y el círculo de giro (3 lugares).
12. Drenar el agua y sedimento del tanque de combustible y filtro de combustible.
13. Reemplazar el aceite del motor y el filtro (a las primeras 50 horas).
14. Verificar la condición de la correa del ventilador (a las primeras 50 horas).

CADA 100 HORAS

15. Verificar y ajustar la correa del ventilador, si es necesario.
16. Cámara de chispas del silenciador. Limpiar la cámara de chispas.
17. Reemplazar el filtro hidráulico (a las primeras 100 horas).
18. Reemplazar aceite en ambas cajas de cadena (mando final) (a las primeras 100 horas).
19. Reemplazar el filtro de la caja de drenaje hidráulico (a las primeras 100 horas).

CADA 250 HORAS

20. Reemplazar el filtro del combustible diesel.
21. Reemplazar el aceite del motor y el filtro.
22. Verificar el nivel de aceite en ambas cajas de cadena (mando final).
23. Verificar la condición de la batería. Limpiar los extremos de los cables.

CADA 500 HORAS

24. Limpiar las aletas de radiador.
25. Reemplazar el filtro hidráulico.
26. Verificar las conexiones del alternador y el motor de arranque.
27. Verificar y ajustar la distancia entre las válvulas del motor.
28. Reemplazar el filtro de la caja de drenaje hidráulico.

CADA 1000 HORAS o CADA 6 MESES

29. Reemplazar el aceite en ambas cajas de cadena (mando final).
30. Drenar y lavar el sistema de enfriamiento. Reemplazar el refrigerante.
31. Reemplazar el fluido hidráulico y el filtro. Limpiar el depósito.

BUCKET SPECIFICATIONS

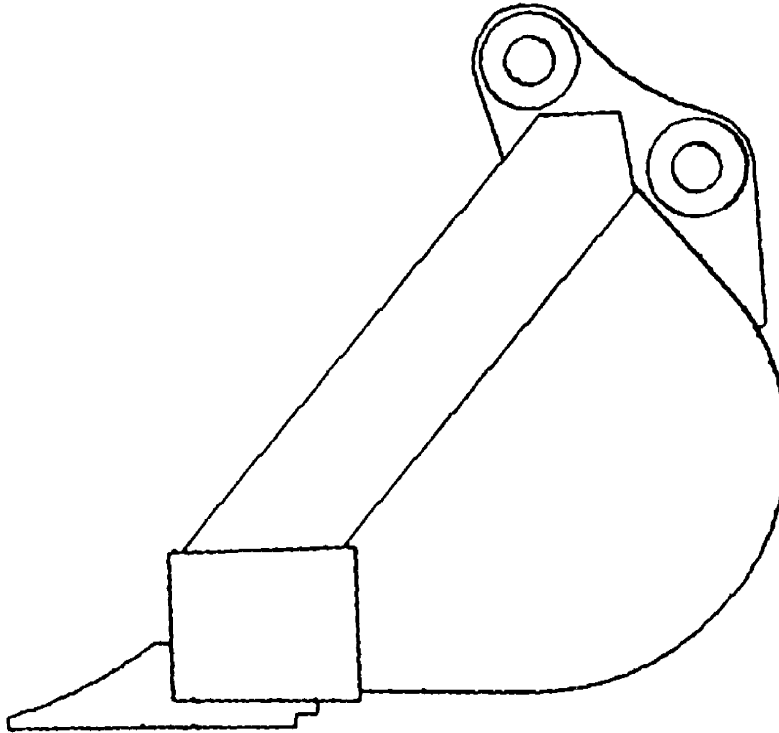

MC-1411

Bucket Size	Capacity SAE Heaped	Shipping Weight
12 inch (305 mm)	1.02 cu. ft. (0,029 cu. m.)	108.7 lbs. (49,3 kg)
16 inch (406 mm)	1.61 cu. ft. (0,046 cu. m.)	125.4 lbs. (56,9 kg)
20 inch (508 mm)	2.36 cu. ft. (0,067 cu. m.)	138.7 lbs. (62,9 kg)
24 inch (609 mm)	2.94 cu. ft. (0,083 cu. m.)	155.2 lbs. (70,4 kg)

FOREWORD

FOREWORD

This manual gives the owner/operator necessary operating and preventive maintenance instructions for the Bobcat Hydraulic Excavator.

Read this manual completely and know the Bobcat Hydraulic Excavator before operating and servicing it. All references to *left* or *right* on the excavator are given in relation to the operator's left or right hand while in the operator's seat.

For further information, see your Bobcat Hydraulic Excavator dealer. Parts Manuals, Service Manuals and extra Operation & Maintenance Manuals are also available.

An Operator training course is available from your Bobcat dealer.

SERIAL NUMBER LOCATIONS	v
DELIVERY REPORT	v
BOBCAT HYDRAULIC EXCAVATOR IDENTIFICATION	vi

CAB OPTION (Cont'd)

Heater Control

The heater controls are located on the left console.

Turn the fan switch (Item 1) [A] to activate the fan. The switch positions are: OFF–LOW–MED–HI.

Turn the temperature switch (Item 2) [A] clockwise to increase the temperature, and counterclockwise to decrease the temperature.

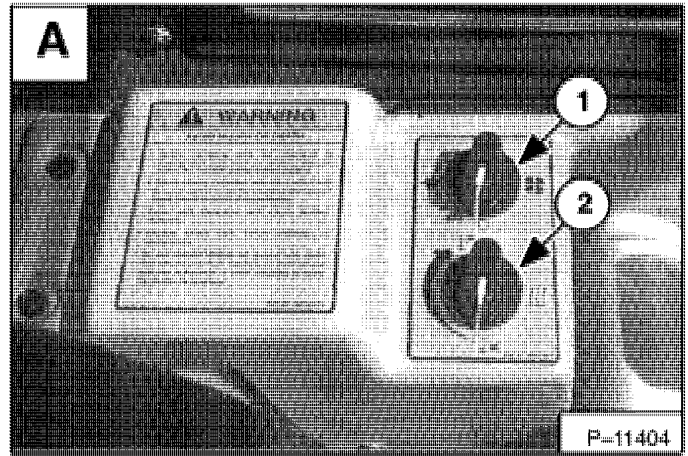

CONSOLE SWITCHES

The switches are located on the left console [B].

1. Switch position – The switch will be installed and used for future functions and/or attachments.
2. Switch (if equipped) – overhead beacon: When this switch is in the ON position, the optional overhead beacon will be activated [B].
3. Switch position – The switch will be installed and used for future functions and/or attachments.
4. Switch position – The switch will be installed and used for future functions and/or attachments.
5. Switch (Standard) – Headlights: When this switch is in the ON (center detent) position, the head lights are activated. When pushed farther to the left (left detent) the head lights are activated plus the available boom work light [B].
6. Switch (Cab option) – Wiper/Washer: When this switch is in the ON (center detent), the wiper is activated. When pushed farther to the left (left detent) and held, the wiper is activated plus the washer motor. The washer sprays fluid on the window and the wiper will continue to run [B].

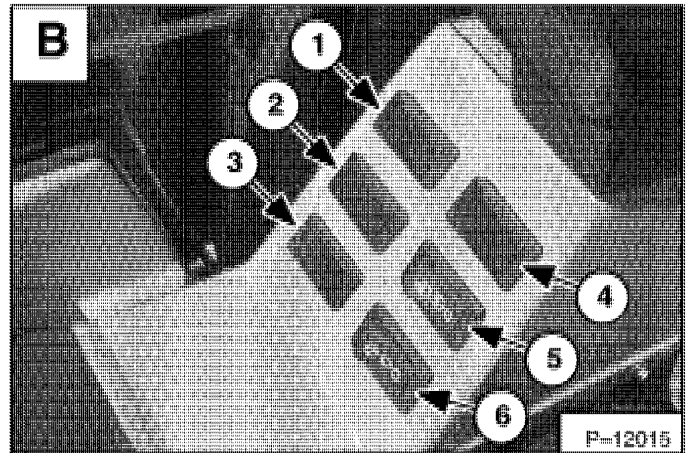

SPEED CONTROL LEVER

The speed control lever (Item 1) [C] is used to control the engine speed.

LOW IDLE POSITION – Pull the lever backward (position A) for low idle.

HIGH IDLE POSITION – Push the lever fully forward (position B) for full engine RPM.

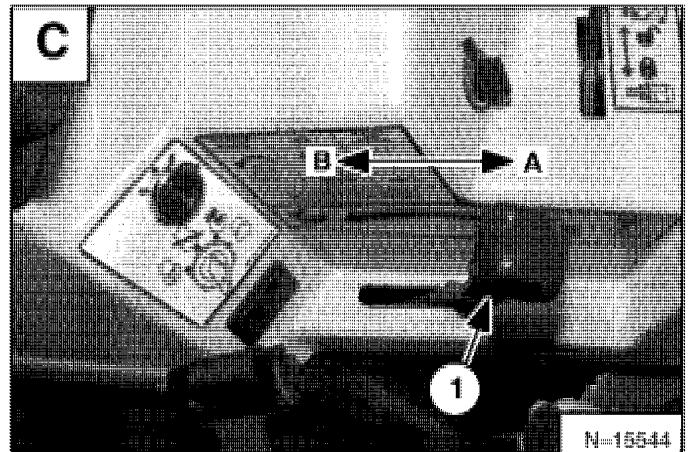

GETTING ON AND OFF THE MACHINE

Use the grab handles, the tracks and the safety treads to get on and off the machine **[A]**.

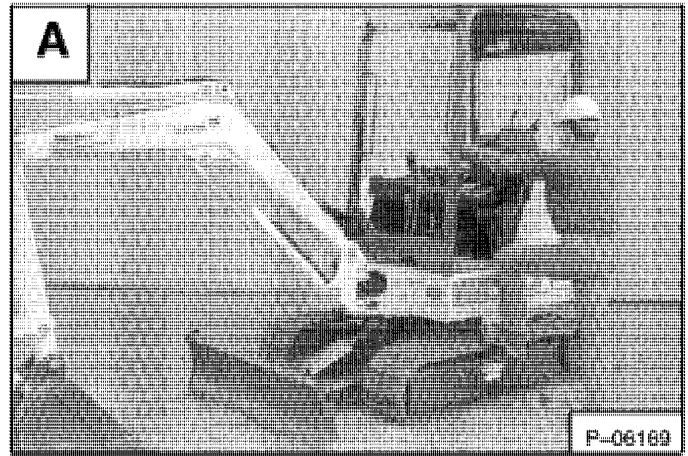

Fasten the seat belt snugly. Adjust the seat belt so that the belt is over the operator's hips **[B]**.

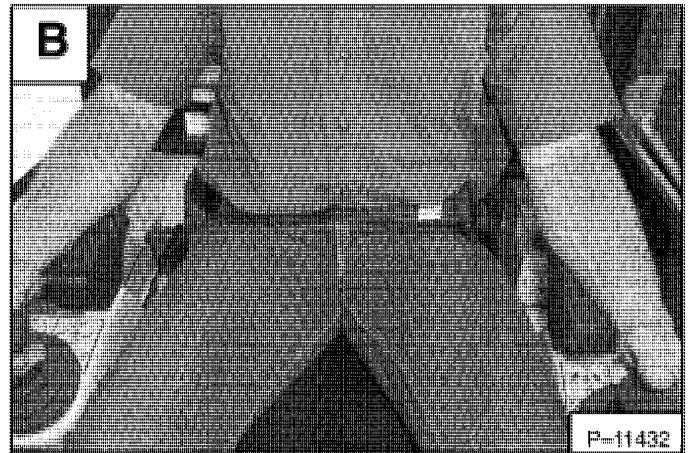

Lower the left control console before starting the engine **[C]**.



To get off of the excavator, lift up on the lever (Item 1) **[D]** to release and raise the control console.

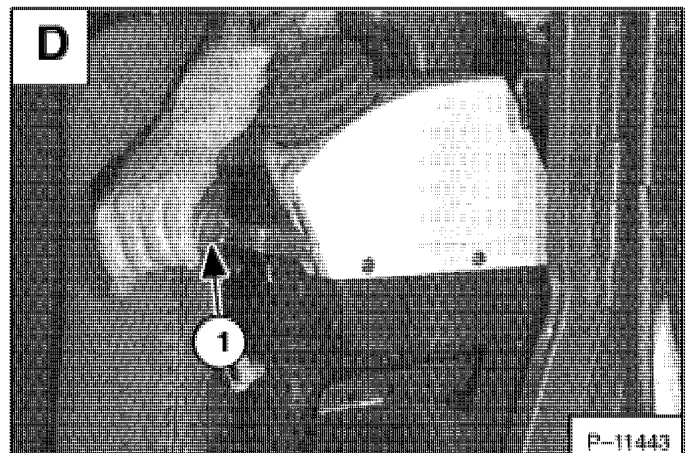

OPERATING PROCEDURE (Cont'd)

Operating On Slopes

When going down a slope, control the speed with the steering levers and the speed control lever.

When going down grades that exceed 15 degrees, put the machine in the position shown, and run the engine slowly [A].

Operate as slow as possible and avoid sudden changes in lever direction.

Avoid traveling over objects (such as rocks, trees, stumps, etc.).

Stop the machine before moving the upper equipment controls. Never allow the blade to strike a solid object. Damage to the blade or hydraulic cylinder can result.

When traveling up slopes or on side slopes that are 15 degrees or less position the machine as shown and run the engine slow [B].

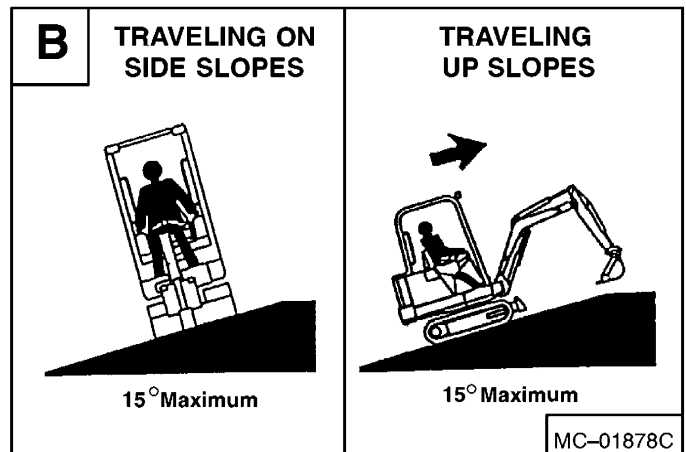
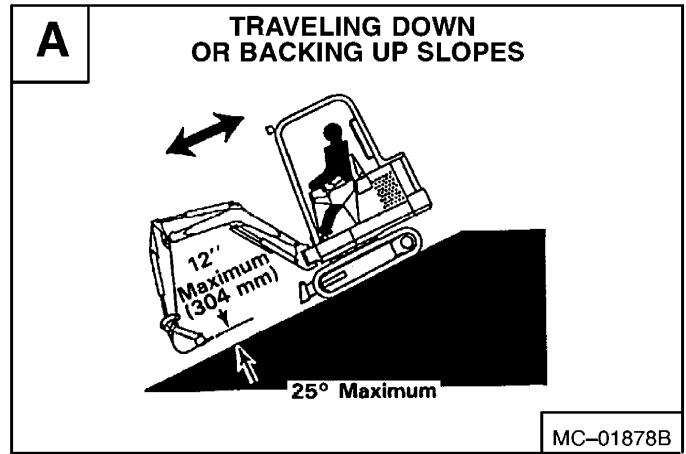

WARNING

AVOID INJURY OR DEATH

- Do not travel across or up slopes which are over 15 degrees to the side, or to the back of machine or 25 degrees to the front. Keep boom centered while traveling.
- Keep attachments as low as possible when traveling on slopes or in rough conditions.

W-2198-0595

WARNING

AVOID INJURY OR DEATH

- Fasten seat belt, start and operate only from the operator seat.

W-2269-1197

AIR CLEANER SERVICE (Cont'd)

Install the new filter element. Install the dust cover and latch the two clamps.

NOTE: Make sure all sealing surfaces are free of dirt and debris.

Only replace the inner filter element (Item 1) [A] under the following conditions.

- Replace the inner filter element every third time the outer filter element is replaced.
- Replace the inner filter element when the red ring still shows in the condition indicator window after the outer filter element is replaced.

NOTE: After replacing the primary (large) filter element, recheck the condition of the inner filter element by pushing the button on the condition indicator (Item 2) [A] and start the engine. Run the engine at full throttle. If the red ring on the condition indicator shows, replace the inner filter element.

Install the dust cover as shown [B].

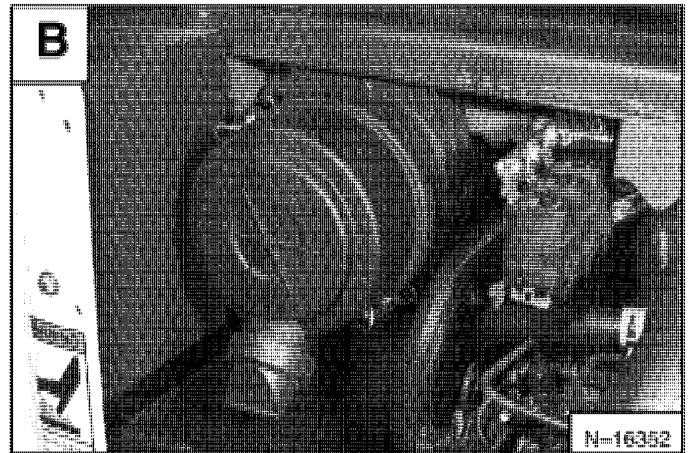
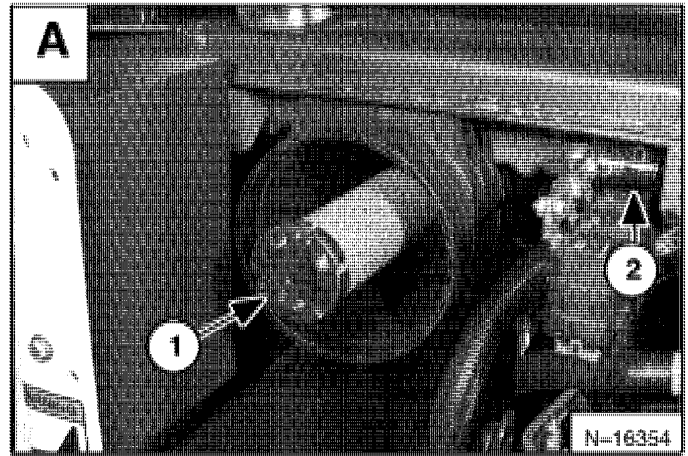

HYDRAULIC SYSTEM

Checking And Adding Fluid

To check and add hydraulic fluid to the reservoir, use the following procedure:

Put the machine on a flat level surface.

Retract the arm and bucket cylinders, put the bucket on the ground and raise the blade. Stop the engine.

Check the hydraulic fluid level, it must be visible in the sight gauge (Item 1) **[A]** located on the side of the hydraulic reservoir.

If the fluid level is not correct, open the hydraulic tank access door **[B]**.

Remove oil fill cap **[B]**.

Check the condition of the fill strainer **[C]**. The screen must be installed in fill neck when adding oil.

Add the correct fluid to the reservoir until it is visible in the sight gauge. (See *FUEL, COOLANT AND LUBRICANTS* Chart Page 81.)

Install the reservoir cap and close and lock the access door.

Diagnostic Couplers

The diagnostic couplers are located on each hydraulic pump (Item 1) **[D]**.

The couplers can be used to check circuit pressures. (Refer to the Service Manual.)

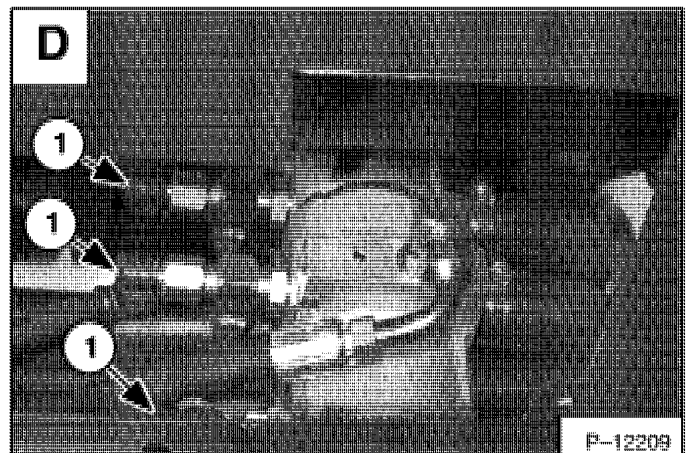
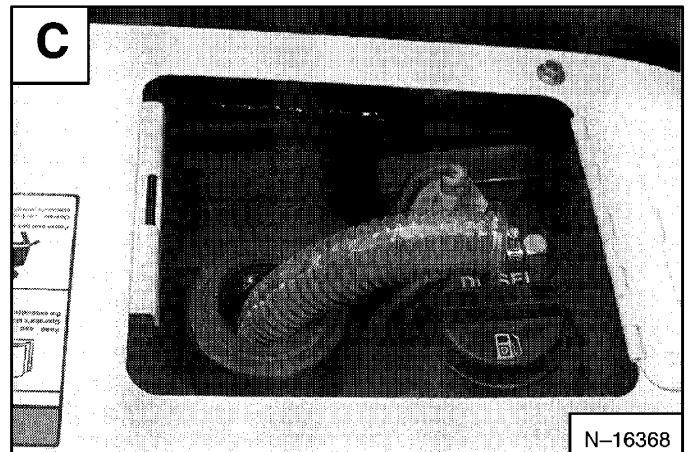
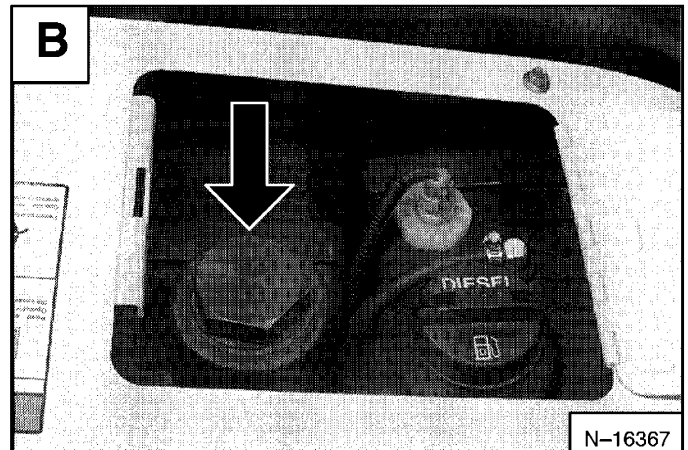
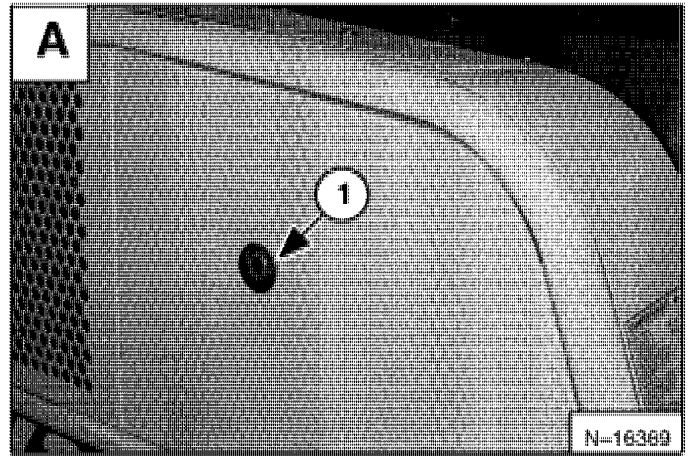

WARNING

Hydraulic fluid escaping under pressure can have sufficient force to enter a person's body by penetrating the skin. This can cause serious injury and possibly death if proper medical treatment by a physician familiar with this injury is not received immediately.

W-2145-0290

LUBRICATION OF THE HYDRAULIC EXCAVATOR (Cont'd)

If the excavator is equipped with the optional lifting clamp, lubricate the following locations on the hydraulic excavator **EVERY 8–10 HOURS**: 

Ref.	Description (# of Fittings)
------	-----------------------------

20.	Clamp Pivot Pin (2) [A].
-----	--------------------------

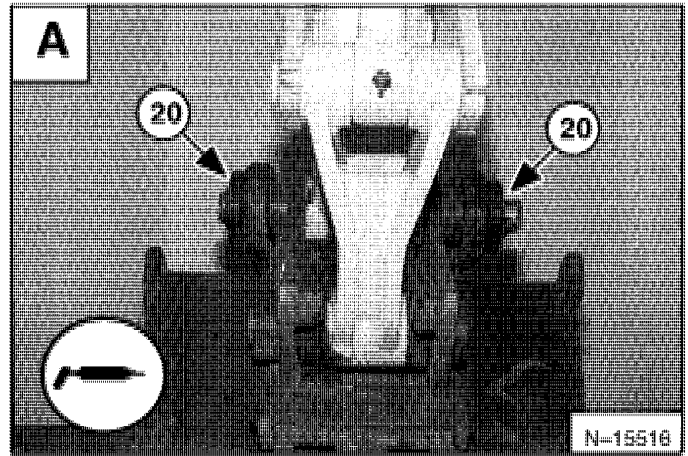

21.	Cylinder Rod End (1) [B].
-----	---------------------------

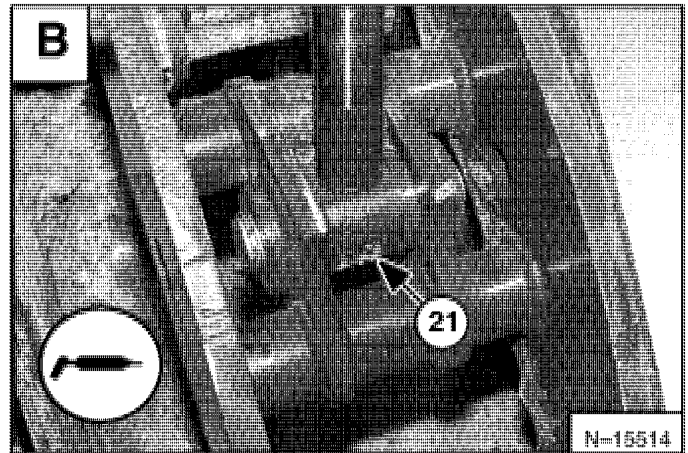

22.	Cylinder Base End (1) [C].
-----	----------------------------

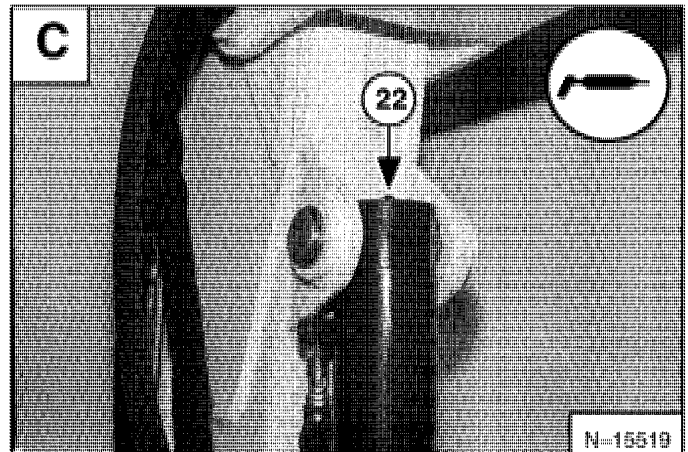

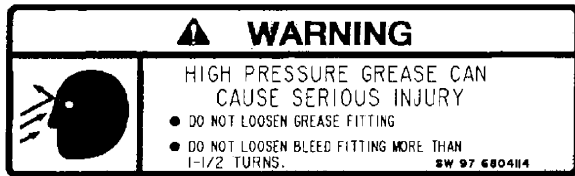

ADVERTENCIA (SPANISH)

EVITE UN ACCIDENTE QUE PUEDE SER MORTAL

No afloje el engrasador más de 1–1/2 vuelta.

No afloje ninguna otra pieza. Está cargado con grasa a presión.

AVERTISSEMENT (FRENCH)

EVITER DES BLESSURES OU LA MORT

Ne pas desserrer le graisseur de plus de 1–1/2 tour.

Ne pas desserrer une pièce autre que le graisseur. La graisse se trouve sous haute pression.



ADVERTENCIA (SPANISH)

EL CILINDRO CONTIENE GAS BAJO ALTA PRESION. EL ABNRRIR EL CILINDRO PUEDE SOLTAR LA VARILLA Y CAUSAR HERIDAS O LA MUERTE.

AVERTISSEMENT (FRENCH)

LES VERINS RENFERMENT UN GAZ SOUS PRESSION. NE JAMAIS OUVRIR UN VERIN CAR LA TIGE RISQUE DE S'ÉCHAPPER BRUTALEMENT ET DE CAUSER DES BLESSURES OU MEME LA MORT.

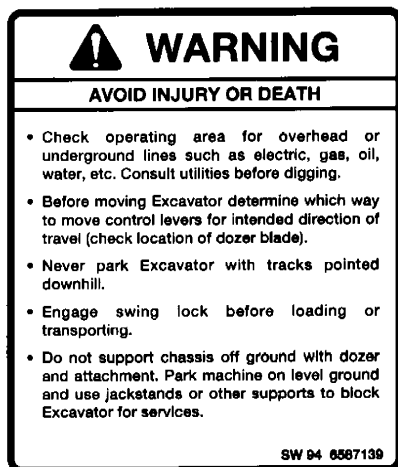

ADVERTENCIA (SPANISH)

Las superficies calientes pueden causar lesiones serias.

No toque.

Permita que se enfríe antes de realizar tareas de mantenimiento.

AVERTISSEMENT (FRENCH)

Risque de brûlures graves sur les surfaces brûlantes.

Ne touchez pas.

Laissez refroidir avant l'entretien.

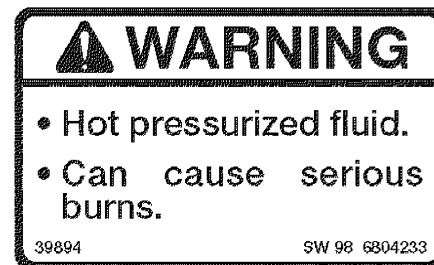

ADVERTENCIA (SPANISH)

- Fluido presurizado caliente.
- Puede provocar quemaduras graves.

AVERTISSEMENT (FRENCH)

- Fluide brûlant sous pression.
- Risque de brûlures graves.

HYDRAULIC EXCAVATOR SPECIFICATIONS 328 (S/N 516611001 & Above) (Cont'd)

		328	
		WITH CANOPY	WITH CAB
WEIGHTS			
Operating Weight (Includes canopy and 20" Bucket)			
W/Rubber Track		5760 lbs. (2613 kg)	6020 lbs. (2731 kg)
W/Steel Track		5906 lbs. (2679 kg)	6166 lbs. (2797 kg)
Travel Speed			
..... (Low)		1.4 MPH (2,2 km/hr.)	
..... (High)		2.2 MPH (3,5 km/hr.)	
CONTROLS			
Vehicle		Two Hand Levers or Optional Foot Levers Two hydraulic joysticks control boom, arm, bucket and cab swing. Foot pedals control boom swing and Aux. Hyds. The blade is controlled by a separate lever.	
Excavator Functions			
ENGINE			
Make		Kubota	
Model		D1703-B	
Fuel		Diesel	
Horsepower		27.5 Hp (20.5 kw) @ 2200 RPM	
Maximum Governed RPM (Full Load)		2200 RPM	
Maximum Torque		74.4 ft.-lbs. (100.8 Nm) @ 1600 RPM	
Number of Cylinders		Three	
Displacement		100.5 cu.-in. (1,7L)	
Bore x Stroke		3.43" x 3.64" (87 mm x 92,4 mm)	
Lubrication		Forced	
Filter		Cartridge Type – Full Flow	
Air Cleaner		Dry replaceable paper cartridge	
ELECTRICAL			
Alternator		12 Volt, 50 Amps.	
Battery		12 Volt, 500 Cold Crank Amps. @ 0° F. (-18° C); 75 Minute Reserve Capacity	
Starter		12 Volt (1,4 Kw), Reduction Drive	
HYDRAULIC SYSTEM			
Number of Pumps		Three	
Type		Triple Section Gear Pump	
Capacity		1 x 7.56 GPM (28,6 L/min.) 2 x 5.82 GPM (22,0 L/min)	
System Main Relief Setting			
Blade Circuit		2650 PSI (18272 kPa)	
Bucket & Arm Circuits		2550 PSI (17582 kPa)	
Boom Circuits		2700 PSI (18617 kPa)	
Travel Circuits		3700 PSI (25512 kPa)	
Swing Circuits		4200 PSI (28959 kPa)	
Auxiliary Flow		13.4 GPM (50,6 L/min.)	
Control Valve(s)		5 Spool Parallel & Series Type	
Drive Motors		Two Axial Piston	
Swing Motor		Orbit Motor	
Hydraulic Function Time			
Bucket		Curl 2.0 Sec.	Dump 1.5 Sec.
Arm		Retract 3.9 Sec.	Extend 2.9 Sec.
Boom		Raise 2.7 Sec.	Lower 3.8 Sec.
Boom Swing		Left 2.4 Sec.	Right 2.2 Sec.
Blade		Raise 3.2 Sec.	Lower 2.5 Sec.
SWING SYSTEM			
Swing Drive		Orbit Motor, Direct Drive	
Swing Circle		Single Row Shear Type Ball Bearings with Internal Gears Built into Swing Circle	
Swing Speed		10.4 RPM	

**325
328**



Bobcat®

Operation & Maintenance Manual

**325 – S/N 232311001 & Above
328 – S/N 232411001 & Above
(D Series)**

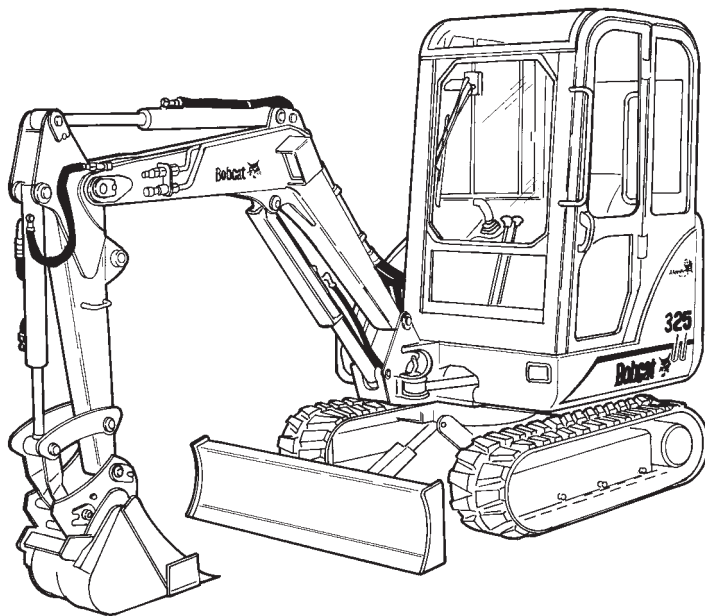

An **IR** Ingersoll Rand business

Printed in U.S.A.

FEATURES AND ACCESSORIES

Model 325 & 328 Bobcat Excavators are equipped with the following Standard items:

Canopy with ROPS / TOPS Approval
55 inch (1397 mm) Dozer Blade
12.6 inch (320 mm) Rubber Tracks
Two-Speed Travel
Auxiliary Hydraulics
Hydraulic and Travel Control Lockouts
Horn
Hydraulic Joystick Controls
ISO / STD Control Pattern Selection Feature
Counterweight Kit (328 only)
Suspension Seat (Standard for 328, Option for 325)
Spark Arrestor Muffler
Rental Investment Protection System (RIPS)
Advanced Diagnostics

Below is a list of some equipment available from your Bobcat Excavator dealer as Dealer and / or Factory Installed Accessories. See your Bobcat dealer for other available options, accessories and attachments.

Factory Options

Enclosed Cab With Heater

Dealer Installed Accessories

Travel Motion Alarm
Keyless Start
Canopy / Cab Mounted Light Kit
Catalytic Exhaust Purifier Kit
Counterweight Kit (325)
Long Arm Kit (325)
X-Change Kit
Top Guard Kit (FOGS)
Special Applications Kit
Vinyl Cab Enclosure
Catalytic Exhaust Purifier

***Specifications subject to
change without notice***

Other

Excavator Operator Training Kit
Excavator Service Safety Training Kit

OPERATING INSTRUCTIONS

ATTACHMENTS (Using The X-Change System)	21
Installing	22
Removing	21
BLADE CONTROL LEVER	14
BOOM SWING PEDAL	14
CAB, OPERATOR (ROPS / TOPS) (If Equipped)	8
Cab Door	8
Emergency Exit	8
Front Window	8
CANOPY, OPERATOR (ROPS / TOPS) (If Equipped)	7
CANOPY ENCLOSURE	7
CANOPY, OPERATOR (ROPS / TOPS)	7
DAILY INSPECTION	15
ENGINE SPEED CONTROL	5
FALLING OBJECT GUARDS (FOGS)	7
HYDRAULIC CONTROLS	11
Auxiliary Hydraulics	13
ISO Control Pattern	11
Left Control Lever	11
Right Control Lever	11
Standard Control Pattern	12
Left Control Lever	12
Right Control Lever	12
Two-Way Flow / One-Way Flow	14
Quick Couplers	13
Relieving Hydraulic Pressure	13
INSTRUMENTS AND CONSOLES	3
Cab Interior Light (If Equipped)	3
Left Console	3
Left Control Lever (See <i>HYDRAULIC CONTROLS</i>)	3
Horn	3
Fan Motor	3
Air Conditioner	3
Temperature Control	3
Wiper / Washer Switch	3
STD / ISO Selector Valve	4
Wiper/Washer Fluid Reservoir (If Equipped)	3
Right Console	4
Right Control Lever (See <i>HYDRAULIC CONTROLS</i>)	4
Auxiliary Hydraulics Switch	4
Blade Control Lever	4
Two-Speed Button	4
Speed Control Lever	4

OPERATING INSTRUCTIONS

Continued On Next Page

HYDRAULIC CONTROLS

ISO Control Pattern

The work equipment (backhoe and upper structure swing) is operated by using the left and right control levers (joysticks) **[A]** & **[B]**.

Left Control Lever

The left lever is used to operate the arm and to swing the upperstructure **[A]**:

1. Arm out.
2. Arm out and slew right.
3. Slew right.
4. Arm in and slew right.
5. Arm in.
6. Arm in and slew left.
7. Slew left.
8. Arm out and slew left.

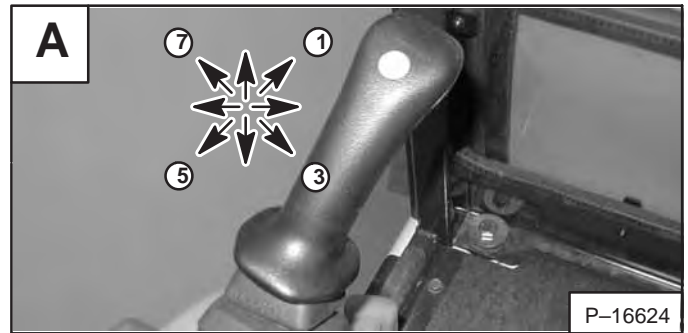

LH - ISO

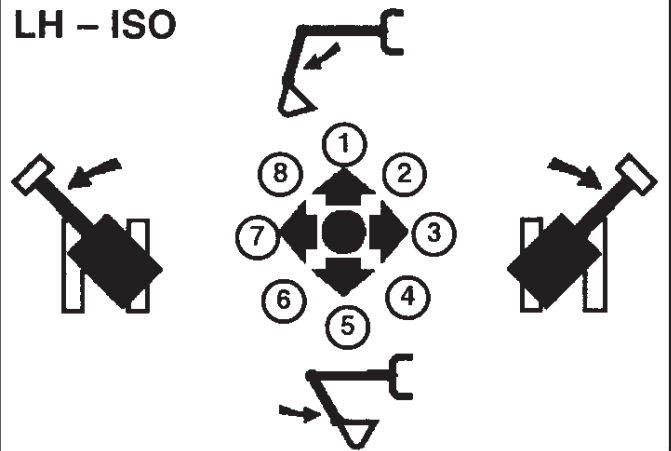

Right Control Lever

The right lever is used to operate the boom and bucket **[B]**.

1. Boom lower.
2. Boom lower and bucket dump.
3. Bucket dump.
4. Boom raise and bucket dump.
5. Boom raise.
6. Boom raise and bucket curl.
7. Bucket curl.
8. Boom lower and bucket curl.

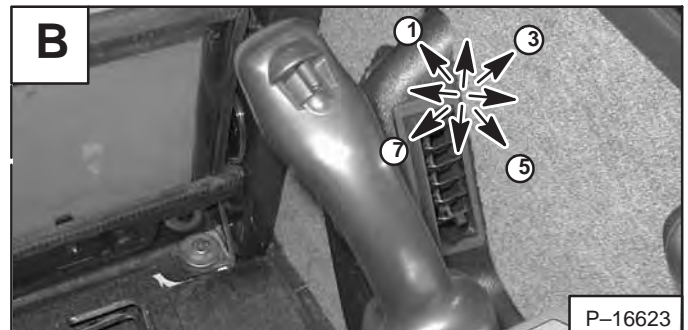

RH - ISO

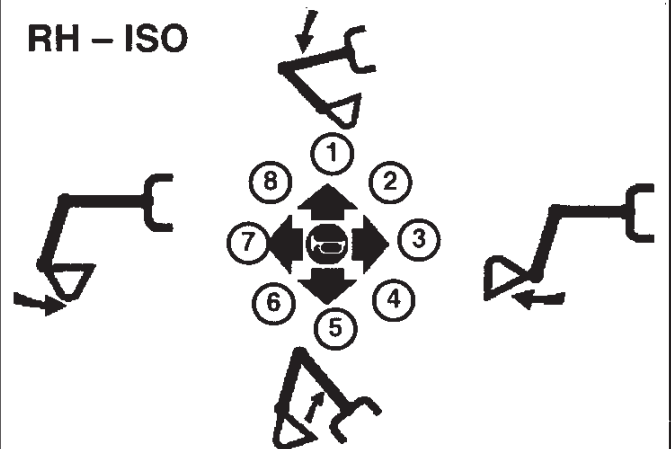

WARNING

AVOID INJURY OR DEATH
Before leaving the machine:

- Lower the work equipment to the ground.
- Lower the blade to the ground.
- Stop the engine. Remove the key.

W-2196-0595

CLICK HERE TO **DOWNLOAD** THE COMPLETE MANUAL

- Thank you very much for reading the preview of the manual.
- You can download the complete manual from: www.heydownloads.com by clicking the link below



- Please note: If there is no response to CLICKING the link, please download this PDF first and then click on it.

CLICK HERE TO **DOWNLOAD** THE COMPLETE MANUAL

ATTACHMENTS (Using the X-Change™ System)

Removing Bucket or Attachment

The excavator is equipped with the X-Change™ system. The X-Change™ is used for fast changing of buckets and attachments.

NOTE: Removal and Installation of the bucket is shown. The procedure is the same for other attachments. Disconnect any hydraulic lines that are operated by hydraulic power before removing any attachments (breaker, auger, etc.).

Stop the machine on a flat level surface. Put the bucket on the ground.

Install the X-Change™ tool (Item 1) [A] in the latch. (The tool is stored in the tailgate.)

Pull the tool (Item 1) [A] to unlock the latch. Remove the tool.

Start the engine, lift the boom approximately one foot, and extend the bucket cylinder until the X-Change™ pins (Item 1) [B] engage the hooks (Item 2) [B] on the bucket.

Retract the bucket cylinder and lower the boom and arm until the bucket is on the ground, and the X-Change™ pins (Item 1) [C] are disengaged from the hooks (Item 2) [C].

Move the arm toward the machine until the X-Change™ pins are clear of the bucket.

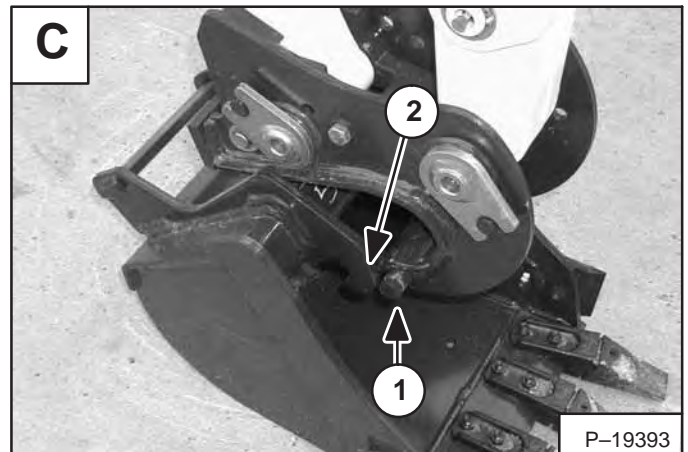
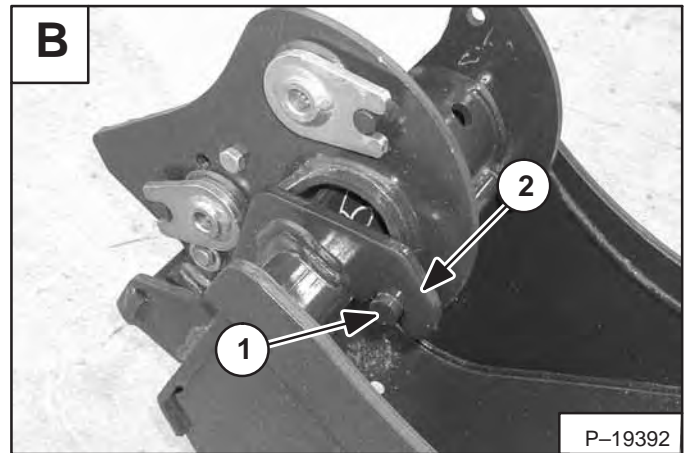
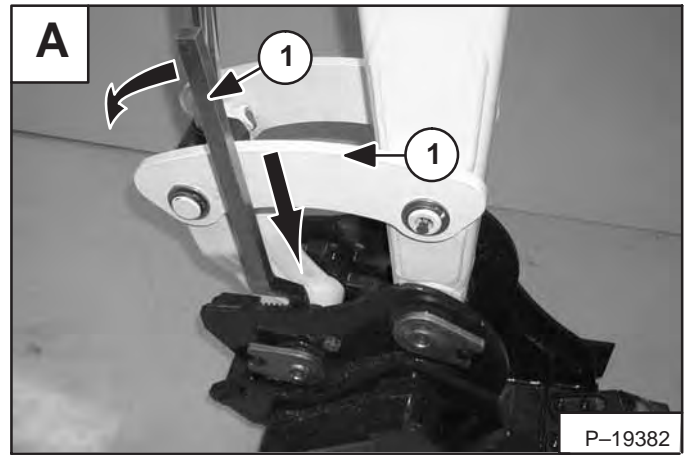

LIFTING THE EXCAVATOR

Fully extend the cylinders of the bucket, arm & boom so that the excavator is in the position as shown [A].

Raise the blade all the way.

Put the all control levers in neutral .



WARNING

AVOID INJURY OR DEATH

- Use a lifting fixture with sufficient capacity for the weight of the excavator plus any added attachments.
- Maintain center of gravity and balance when lifting.
- Do not swing boom or upperstructure. Engage the swing locking lever.
- Never lift with operator on machine.

W-2202-0595

Fasten chains to the ends of the blade (Item 1) [A] & [B] and up to a lifting fixture above the canopy/cab. The lifting fixture must extend over the sides of the canopy/cab to prevent the chains from hitting the ROPS/TOPS.

Install a 1 inch (25mm) bolt and nut (Grade 5 or 8) through the holes at the top of the boom (Item 2) [A] & [B]. Fasten a chain from the bolt to the lift fixture.

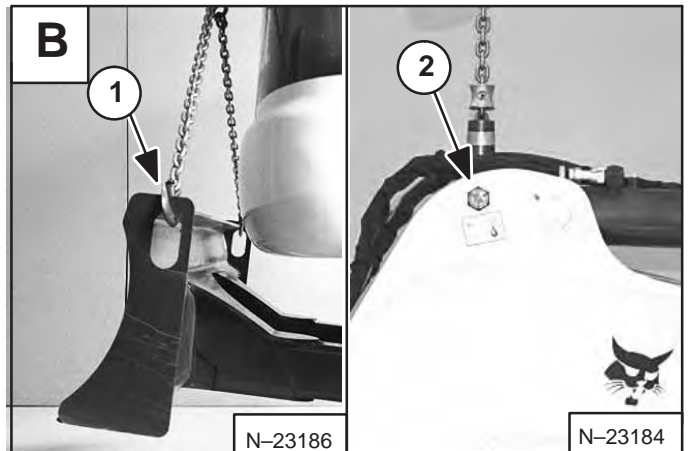
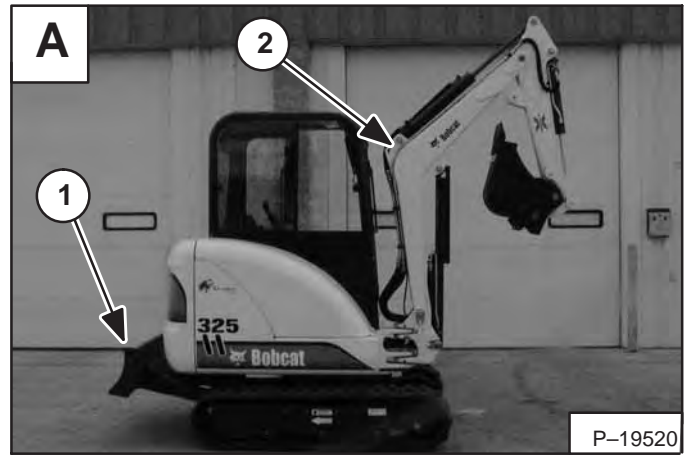

COOLING SYSTEM

Check the cooling system every day to prevent over-heating, loss of performance or engine damage.

Cleaning The Cooling System

Open the tailgate.

Use air pressure or water pressure to clean the radiator and oil cooler [A]. Be careful not to damage fins when cleaning.

Checking Coolant Level

! WARNING

Do not remove radiator cap when the engine is hot. You can be seriously burned.

W-2070-1285

Open the right side cover.

Check the coolant level in the coolant recovery tank (Item 1) [B].

The coolant level must be between the MIN and MAX marks on the coolant recovery tank when the engine is cold.

NOTE: The cooling system is factory filled with propylene glycol (purple color). DO NOT mix propylene glycol with ethylene glycol.

IMPORTANT

AVOID ENGINE DAMAGE

Always use the correct ratio of water to anti-freeze.

Too much antifreeze reduces cooling system efficiency and may cause serious premature engine damage.

Too little antifreeze reduces the additives which protect the internal engine components; reduces the boiling point and freeze protection of the system.

Always add a premixed solution. Adding full strength concentrated coolant can cause serious premature engine damage.

I-2124-0497

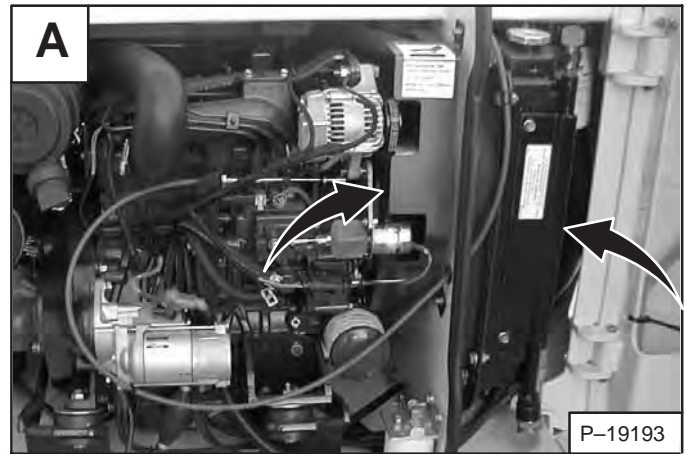

! WARNING

Wear safety glasses to prevent eye injury when any of the following conditions exist:

- When fluids are under pressure.
- Flying debris or loose material is present.
- Engine is running.
- Tools are being used.

W-2019-1285

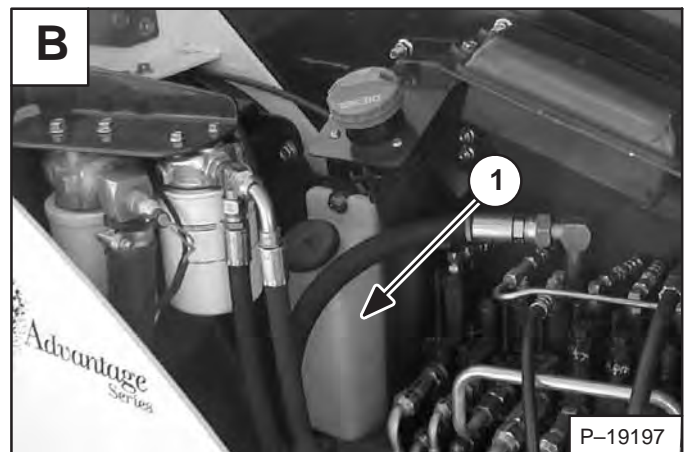

TRACK TENSION

NOTE: The wear of the pins and bushings on the undercarriage vary with the working conditions and the different types of soil conditions. It is necessary to inspect track tension and maintain the correct tension. See **Service Schedule, Page 35** for the correct service interval.

Raise one side of the machine (Approximately four inches) using the boom and arm [A].

Raise the blade fully and install jackstands under the blade and track frame (Item 1) [A]. Lower the boom until all machine weight is on the jackstands.

Stop the engine.



Rubber Track Clearance

Measure the sag at the middle track roller [B]. Do Not get fingers into pinch points between the track and the track roller. Use a bolt or a dowel of the appropriate size to check the gap between the contact edge of the roller and the top edge of the track guide lug [B] & [C].

Rubber Track Clearance
0.562 inch (15,0 mm)

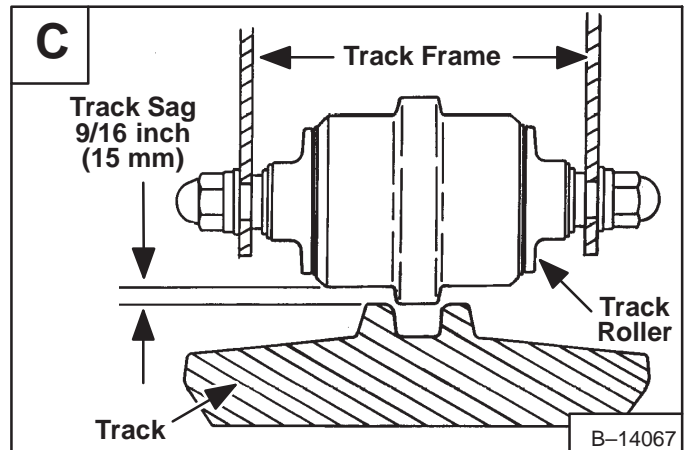
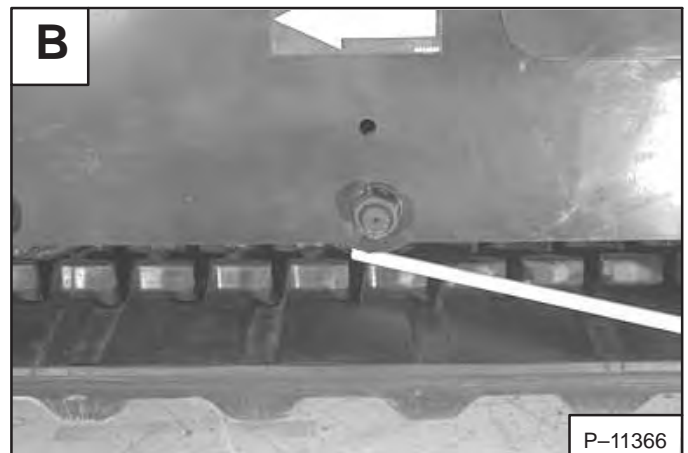
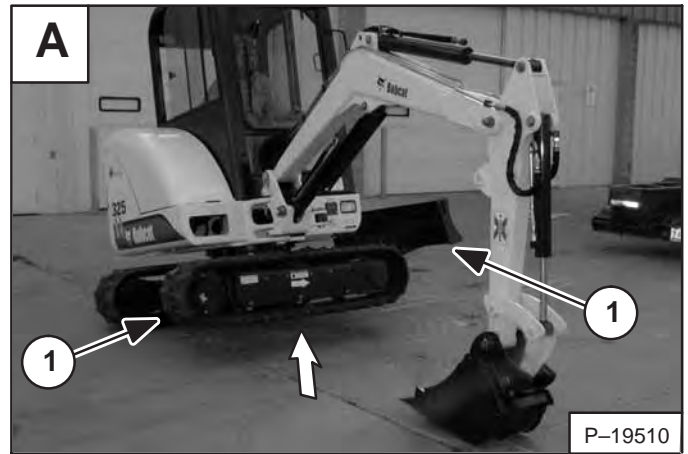

DELUXE INSTRUMENT PANEL SETUP (Cont'd)

Password Lockout Feature

This allows the operator to Unlock the password feature so that a password does not need to be used every time you start the engine.

Perform Password Entry (Page 60). (The engine can be started or stopped.)

Press the Lock/Unlock Button (Item 1) [A]. The LCD will continuously alternate from **UnLoc** to **CodE** for 1 second periods.

Perform Password Entry again.

UnLoc will appear in the LCD (Item 5) [A], the Unlocked Icon (Item 2) [A] will appear in the Icon Display Area (Item 3) [A] and there will be two short beeps.

To start an Unlocked system, press the ENTER CODE Button and press the START Button.

When you stop the engine with the system unlocked, you will hear one long beep every 3 seconds for 15 seconds.

To lock the system again, press the Lock/Unlock Button (Item 1) [A] and enter the password during the 15 second period.

Job Clock

The JOB CLOCK can be set to record accumulated hours for a particular job.

Press and release the HOURS/JOB/RPM Button (Item 4) [A] until JOB light is ON at the top, center of the LCD (Item 5) [A].

While the JOB light is ON, press and hold the HOURS/JOB/RPM Button (Item 4) [A] until the LCD retruns to zero.

This process will clear the accumulated hours and will begin recording JOB CLOCK time again. (This does not affect the HOURMETER which continues to record the total operating hours of the excavator.)

Pressing the HOURS/JOB/RPM Button again or pressing the START Button will return the LCD to HOURMETER function.

RPM

The LCD (Item 5) [A] can be set to display engine RPM.

With the engine running, press and release the HOURS/JOB/RPM Button (Item 4) [A] until RPM light is ON at the top, left of the LCD (Item 5) [A].

Engine RPM is now displayed in the LCD.

Press the HOURS/JOB/RPM Button (Item 4) [A] again the return to HOURMETER function.

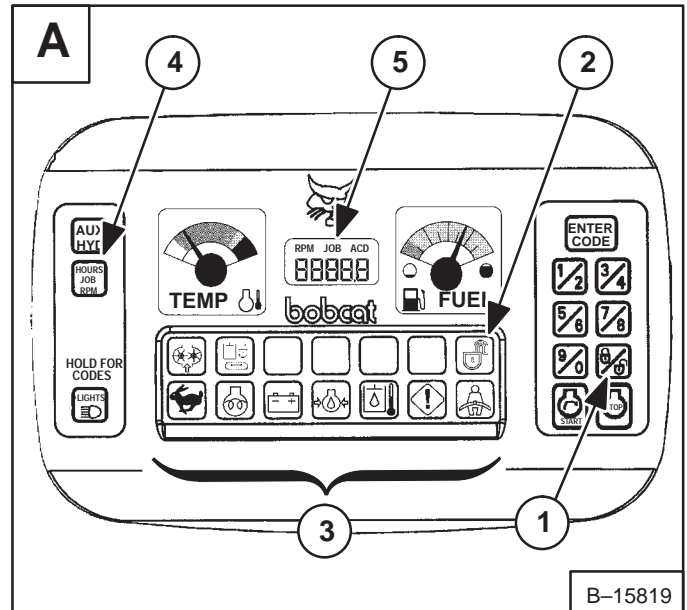

B-15819

SERVICE SCHEDULE

EVERY 8-10 HOURS

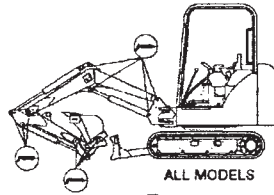

EVERY 50 HOURS

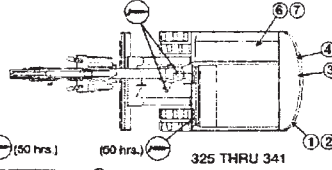

EVERY 100 HOURS

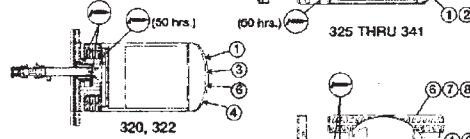

EVERY 250 HOURS

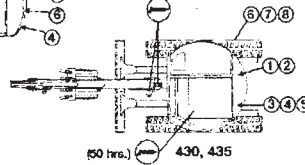

EVERY 500 HOURS

EVERY 1000 HOURS OR EVERY 6 MONTHS

FILTER CHART

	320, 322	325, 328	331, 334 331E	337, 341	430	435
1. PRIMARY AIR FILTER	6673752	6672467	6666333	6666375	6666333	6666375
2. SECONDARY AIR FILTER	6673753	6672468	6666334	6666376	6666334	6666376
3. ENGINE OIL FILTER	3074113B	6675517	6675517	6675517	6675517	6675517
4. FUEL FILTER	6667362	6667362	6667362	6667362	6667362	6667362
5. IN-LINE FUEL FILTER	N/A	N/A	N/A	N/A	6633977	6633977
6. PRIMARY HYDRAULIC FILTER	6633336	6661248	6661248	6670207	6661248	6661248
7. SECONDARY HYDRAULIC FILTER	N/A	6616722	6616722	6616722	6681012	6681072
8. CASE HYDRAULIC FILTER	N/A	N/A	N/A	N/A	6681012	6681012

* See illustrations above for filter locations.

43504

SW 02 6815092

BOBCAT APPROVED ATTACHMENTS & ACCESSORIES

These and other attachments are approved for use on this model Bobcat excavator. Do not use unapproved attachments. Attachments not manufactured by Bobcat may not be approved.

The versatile Bobcat excavator quickly turns into a multi-job machine with a variety of attachments.

See your Bobcat dealer for more details on these and other attachments and field accessories.

Increase the versatility of your Bobcat Excavator with a variety of bucket sizes.

BUCKETS AVAILABLE

Many different bucket widths/capacities are available for a variety of applications. See your Bobcat dealer for the correct bucket for your application.

Trenching Bucket

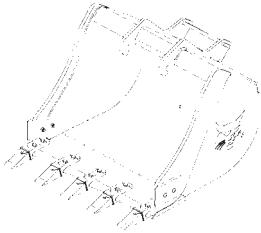

Grading Bucket



Bucket Specifications

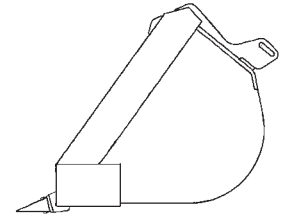

Bucket Size	Capacity SAE Heaped	Shipping Weight
13 inch (330 mm)	2.10 cu. ft. (0.059 cu. m.)	215.5 lbs. (97,6 kg)
18 inch (460 mm)	3.35 cu. ft. (0.095 cu. m.)	261.0 lbs. (118,4 kg)
24 inch (610 mm)	4.95 cu. ft. (0.141 cu. m.)	303.3 lbs. (137,6 kg)
30 inch (760 mm)	6.60 cu. ft. (0.187 cu. m.)	358.0 lbs. (162,4 kg)
36 inch (914 mm)	8.24 cu. ft. (0,234 cu. m.)	388.9 lbs. (176,4 kg)
52 inch (1321 mm)	6.26 cu. ft. (0,177 cu.m.)	337.0 lbs. (153,2 kg)

ATTACHMENTS

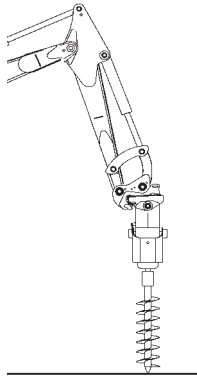
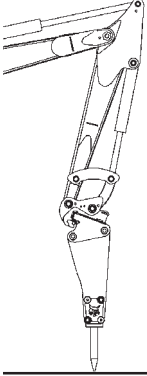
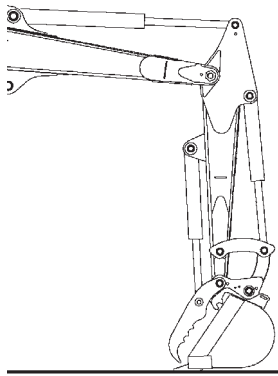
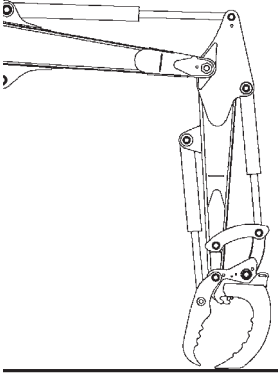
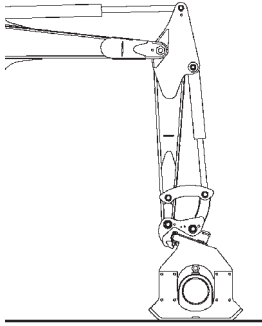
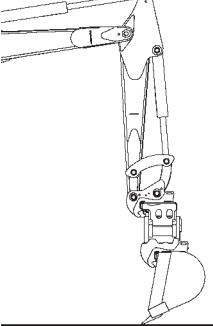
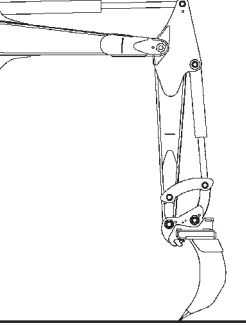
<p style="text-align: center;">Auger</p>  <p style="text-align: center;">TS-01942</p> <p>Dig 6" – 36" holes with ease and accuracy.</p>	<p style="text-align: center;">Breaker</p>  <p style="text-align: center;">TS-01943</p> <p>Break up concrete quickly and easily.</p>	<p style="text-align: center;">Hydraulic Clamp</p>  <p style="text-align: center;">TS-01944</p> <p>Use with a bucket to pick up debris. Requires the use of port relief valves in the auxiliary valve circuit.</p>	<p style="text-align: center;">3 – Tined Grapple</p>  <p style="text-align: center;">TS-01946</p> <p>Must be used with X-Change™ system. Use with the hydraulic clamp to pick up debris, rocks, etc.</p>
<p style="text-align: center;">Compactor</p>  <p style="text-align: center;">TS-01945</p> <p>Must be used with the X-Change™ system. Use for compacting soil after the excavating job is finished.</p>	<p style="text-align: center;">Power-Tilt</p>  <p style="text-align: center;">TS-01947</p> <p>Must be used with the X-Change™ system. Used for rotating the bucket to cut at angles and for finishing work.</p>	<p style="text-align: center;">Ripper</p>  <p style="text-align: center;">TS-01948</p> <p>Must be used with the X-Change™ system. Used for penetrating and to scarify frost or hard ground.</p>	

FOREWORD

FOREWORD

This Operation & Maintenance Manual was written to give the owner / operator instructions on the safe operation and maintenance of the Bobcat Excavator. READ AND UNDERSTAND THIS OPERATION & MAINTENANCE MANUAL BEFORE OPERATING YOUR BOBCAT EXCAVATOR. If you have any questions, see your Bobcat Excavator dealer.

BOBCAT COMPANY IS ISO 9001:2000 CERTIFIED	V
DELIVERY REPORT	VII
EXCAVATOR IDENTIFICATION	VIII
FEATURES, ACCESSORIES AND ATTACHMENTS	IX
Attachments	IX
Buckets Available	IX
Falling Object Guards (FOGS)	X
Options and Accessories	IX
Special Applications Kit	X
Special Applications Kit Inspection And Maintenance	X
Standard Items	IX
REGULAR MAINTENANCE ITEMS	V
SERIAL NUMBER LOCATIONS	VII
Engine Serial Number	VII
Excavator Serial Number	VII

SAFETY INSTRUCTIONS

Before Operation

Carefully follow the operating and maintenance instructions in this manual.

The Bobcat Excavator is highly maneuverable and compact. It is rugged and useful under a wide variety of conditions. This presents an operator with hazards associated with off highway, rough terrain applications, common with Bobcat Excavator usage.

The Bobcat Excavator has an internal combustion engine with resultant heat and exhaust. All exhaust gasses can kill or cause illness so use the Excavator with adequate ventilation.

The dealer explains the capabilities and restrictions of the Bobcat Excavator and attachment for each application. The dealer demonstrates the safe operation according to Bobcat instructional materials, which are also available to operators. The dealer can also identify unsafe modifications or use of unapproved attachments. The attachments and buckets are designed for a Rated Lift Capacity. They are designed for secure fastening to the Bobcat Excavator. The user must check with the dealer, or Bobcat literature, to determine safe loads of materials of specified densities for the machine - attachment combination.

The following publications and training materials provide information on the safe use and maintenance of the Bobcat machine and attachments:

- The Delivery Report is used to assure that complete instructions have been given to the new owner and that the machine and attachment is in safe operating condition.
- The Operation & Maintenance Manual delivered with the machine or attachment gives operating information as well as routine maintenance and service procedures. It is a part of the machine and can be stored in a container provided on the machine. Replacement Operation & Maintenance Manuals can be ordered from your Bobcat dealer.
- Machine signs (decals) instruct on the safe operation and care of your Bobcat machine or attachment. The signs and their locations are shown in the Operation & Maintenance Manual. Replacement signs are available from your Bobcat dealer.

- An Operator's Handbook is fastened to the operator cab of the Excavator. It's brief instructions are convenient to the operator. The Handbook is available from your dealer in an English edition or one of many other languages. See your Bobcat dealer for more information on translated versions.
- The AEM Safety Manual delivered with the machine gives general safety information.
- The Compact Excavator Operating Training Course is available through your Bobcat dealer. This course is intended to provide rules and practices of correct operation of the Bobcat Excavator. The course is available in English and Spanish versions.
- Service Safety Training Courses are available from your Bobcat dealer. They provide information for safe and correct service procedures.
- See the PUBLICATIONS AND TRAINING RESOURCES Page in this manual or your Bobcat dealer for Service and Parts Manuals, printed materials, videos, or training courses available. Also check the Bobcat web sites www.training.bobcat.com or www.bobcat.com

The dealer and owner / operator review the recommended uses of the product when delivered. If the owner / operator will be using the machine for a different application(s) he or she must ask the dealer for recommendations on the new use.



Call Before You Dig
1-888-258-0808

When you call, you will be directed to a location in your state / city for information about buried lines (telephone, cable TV, water, sewer, gas, etc.)

SI EXC-0206

INSTRUMENTS AND CONSOLES (CONT'D)

Function Icons

The table below shows the Icons, their function and other important information.

REF.	FUNCTION	ICON / LIGHT	ALARM	CONDITION / CODE	DESCRIPTION
1	Auxiliary Hydraulics	OFF CONTINUOUS FLASHING	--- 3 Beeps	--- Error ♦	Auxiliary Hydraulics Button pressed, hydraulic functions available. Error with Auxiliary Hydraulics.
2	Two-Speed Travel	OFF CONTINUOUS FLASHING	--- 3 Beeps	--- Error ♦	Two-Speed activated, High Range engaged Solenoid Error
3	Hydraulic / Traction Drive	CONTINUOUS OFF FLASHING FLASHING	--- 3 Beeps CONTINUOUS	* --- Error ♦ Error ♦	Left Console down. Hydraulic / Traction Drive functions activated Left Console up. Hydraulic / Traction Drive functions deactivated Error with console sensor or workgroup solenoid Workgroup solenoid not connected
4	Glow Plugs	OFF CONTINUOUS FLASHING	--- 3 Beeps	* --- Error ♦	Glow Plugs energized Error with Glow Plugs
5	System Voltage	OFF FLASHING	--- 3Beeps 3 Beeps CONTINUOUS CONTINUOUS	* Error ♦ Warning ♦ Warning ♦ Shutdown ♦	Voltage out of range Voltage low or high Voltage extremely high Voltage extremely low - Engine will stop in 10 seconds.
6	Engine Oil Pressure	OFF CONTINUOUS CONTINUOUS FLASHING	--- 3Beeps 3 Beeps CONTINUOUS	* Error ♦ Warning ♦ Shutdown ♦	Engine Oil Pressure sender out of range. Engine Oil level low. Engine Oil pressure very low, Engine will shutdown in 10 seconds.
7	Hydraulic Oil Filter & Temperature	OFF FLASHING CONTINUOUS CONTINUOUS FLASHING	--- 3Beeps 3 Beeps 3 Beeps CONTINUOUS	* Warning ♦ Error ♦ Warning ♦ Shutdown ♦	Error with Hydraulic Filter Hydraulic Oil Temperature out of range Hydraulic Filter plugged or temperature high Hydraulic Oil Temp. extremely high - Engine will stop in 10 seconds.
8	General Warning	OFF CONTINUOUS CONTINUOUS FLASHING	--- 3Beeps 3 Beeps CONTINUOUS	* Error ♦ Warning ♦ Shutdown ♦	Error with one or more engine, hydraulic, or fuel functions. Low fuel, engine speed high, coolant temperature high Coolant temperature or engine speed extremely high - Engine will stop in 10 seconds.
9	Keypad Unlocked	ON OFF	--- ---	--- ---	Panel is unlocked
10	Seat Belt	ON	---	---	Light stays on for 45 seconds to remind operator to fasten seat belt.
11	Low Fuel	OFF CONTINUOUS	--- 3 Beeps	--- Warning	Light stays on

* This is the normal operating condition.

♦ These functions are monitored and have SERVICE CODES associated with them, See SYSTEM SETUP & ANALYSIS Page SA-3 for descriptions of SERVICE CODES.

Figure OI-4

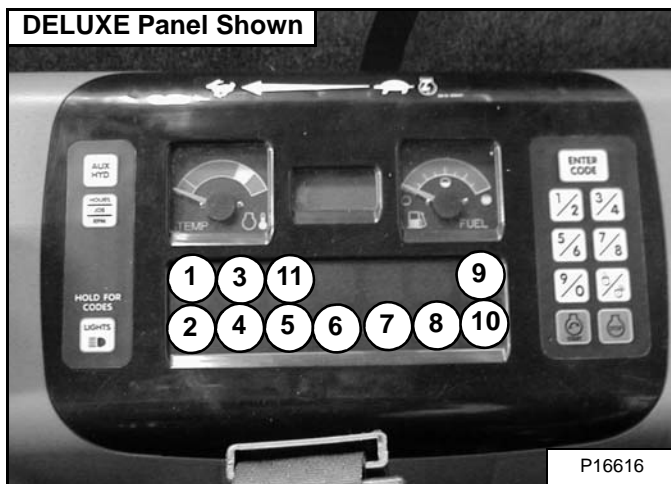

The right console contains the instrument panel with Function Icons [Figure OI-4].

TRAVEL CONTROLS (CONT'D)

Turning (Cont'd)

Counter - Rotation Right Turn

Figure OI-31

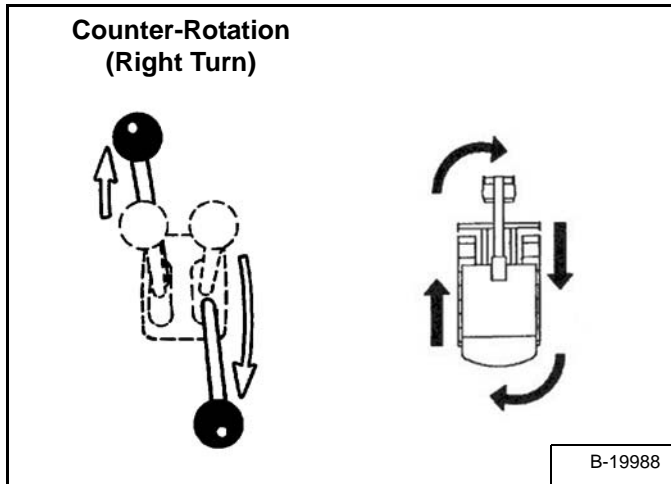

Push the left steering lever forward and pull the right steering lever backward [Figure OI-31].

Left Turn

Figure OI-32

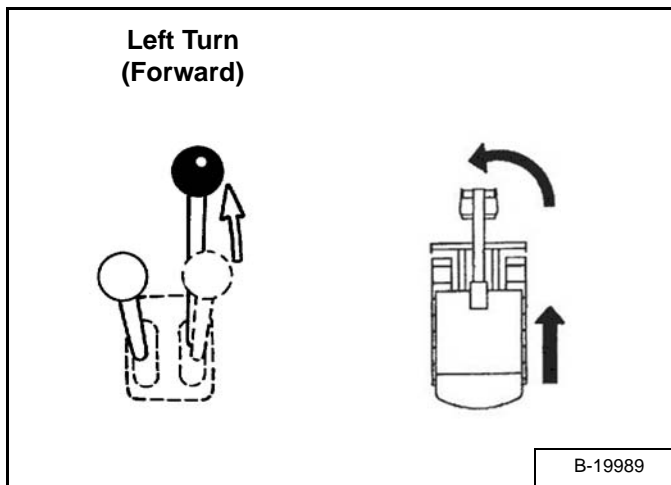

Push the right steering lever forward to turn left while traveling forward [Figure OI-32].

Figure OI-33

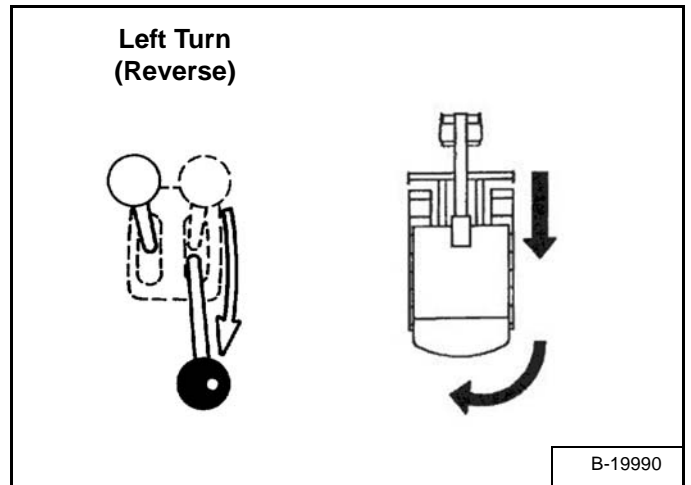

Pull the right steering lever backward to turn left while traveling backward [Figure OI-33].

Counter-Rotation Left Turn

Figure OI-34

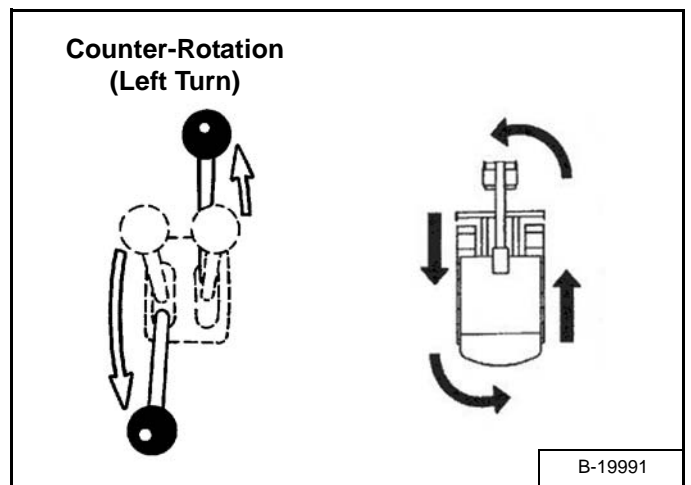

Push the right steering lever forward and pull the left steering lever backward [Figure OI-34].

STARTING THE ENGINE

Key Switch

! WARNING

AVOID INJURY OR DEATH

- Fasten seat belt, start and operate only from the operator's seat.
- Never wear loose clothing when working near machine.

W-2135-1108

Perform the PRE-STARTING PROCEDURE. (See PRE-STARTING PROCEDURE on Page OI-25.)

Figure OI-55

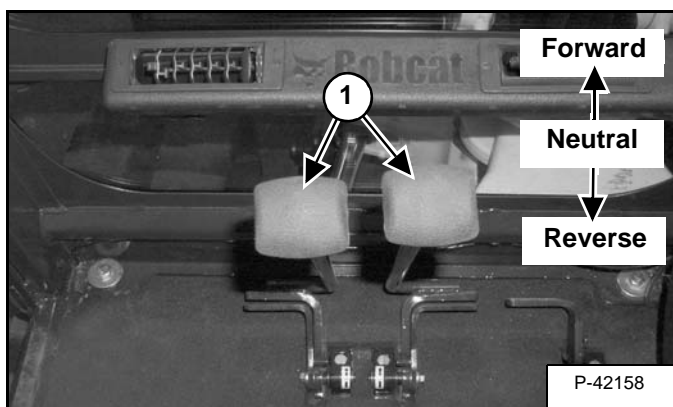

Put control levers (Item 1) [Figure OI-55] in the neutral position.

Figure OI-56



Move the engine speed control (Item 1) [Figure OI-56] to low idle.

! WARNING

AVOID INJURY OR DEATH

When an engine is running in an enclosed area, fresh air must be added to avoid concentration of exhaust fumes. If the engine is stationary, vent the exhaust outside. Exhaust fumes contain odorless, invisible gases which can kill without warning.

W-2050-0807

Figure OI-57

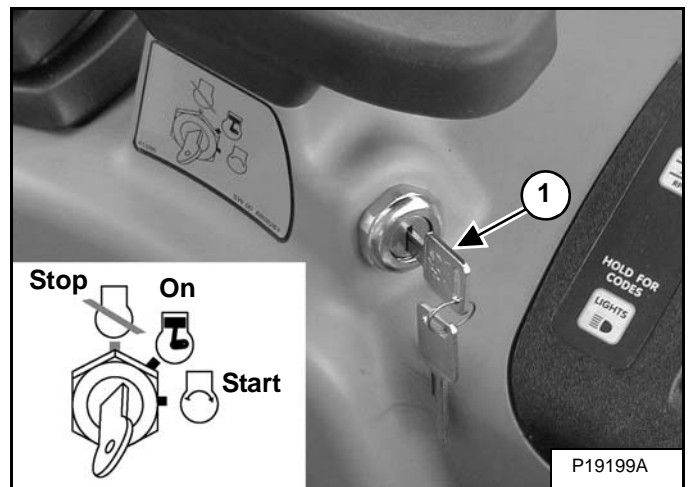

Turn the key (Item 1) [Figure OI-57] to the ON position. If preheating is required, the glowplugs will automatically cycle and the remaining preheat time (in seconds) will show in the LCD. (Preheat icon will be ON).

Turn the key to START and release the key when the engine starts. It will return to the ON position [Figure OI-57].

Stop the engine if the warning lights and alarm do not go OFF. Check for the cause before starting the engine again.

Turn the key switch OFF to stop the engine.

IMPORTANT

Do not engage the starter for longer than 15 seconds at a time. Longer use can damage the starter by overheating. Allow starter to cool for one minute before using starter again.

I-2034-0700

! WARNING

AVOID INJURY OR DEATH

- Engines can have hot parts and hot exhaust gas. Keep flammable material away.
- Do not use machines in atmosphere containing explosive gas.

W-2051-1086

ATTACHMENTS (CONT'D)

Installing And Removing The Attachment (Pin-On X-Change) (Cont'd)

Removal (Cont'd)

Figure OI-77

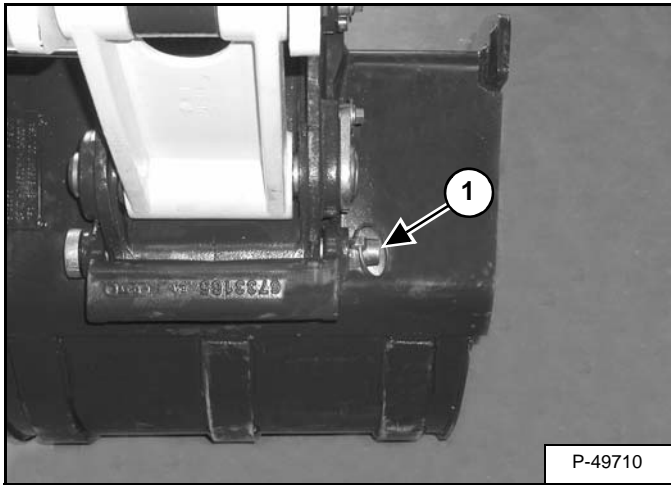

Remove the retainer pin (Item 1) [Figure OI-99].

Figure OI-78

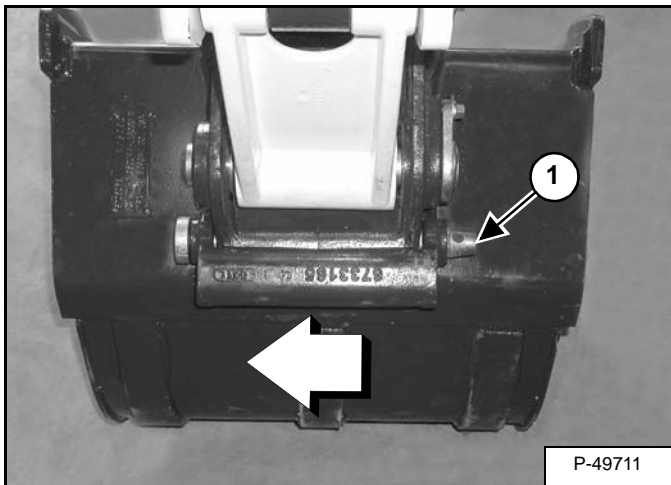

Drive the pin (Item 1) [Figure OI-100] out of the bucket and X-Change mount.

WARNING

AVOID INJURY OR DEATH

Wear safety glasses to prevent eye injury when any of the following conditions exist:

- When fluids are under pressure.
- Flying debris or loose material is present.
- Engine is running.
- Tools are being used.

W-2019-0907

Figure OI-79

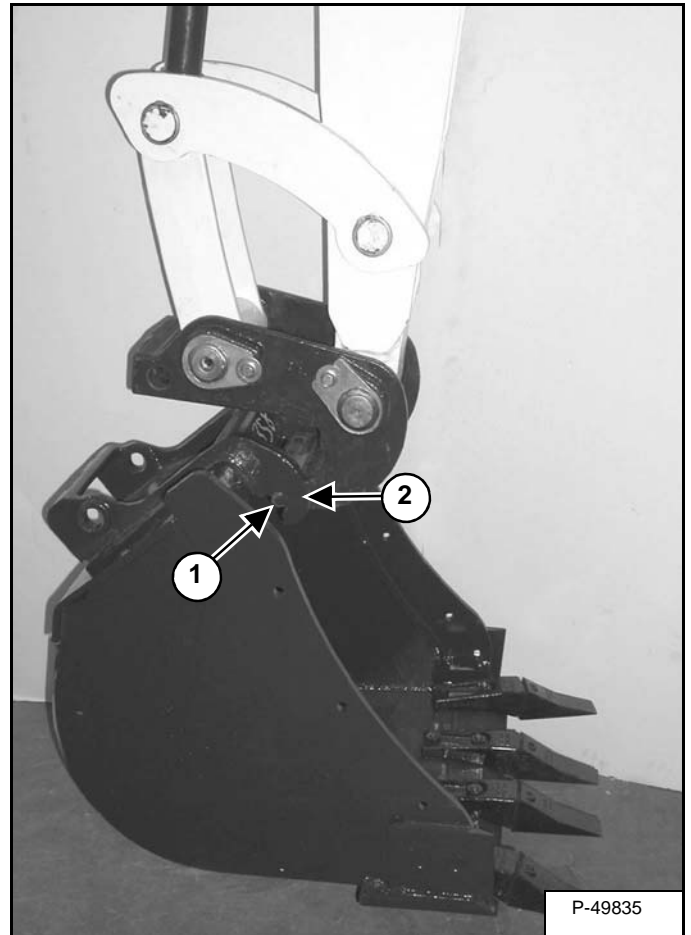

Start the engine, raise the boom approximately one foot and retract the bucket cylinder until the X-Change pins (Item 1) engage the hooks (Item 2) [Figure OI-79] on the bucket.

ATTACHMENTS (CONT'D)

Installing And Removing The Attachment (Latching X-Change System) (Cont'd)

Removal

The excavator is equipped with the X-Change system. The X-Change is used for fast changing of buckets and attachments.

NOTE: Removal and installation of the bucket is shown. The procedure is the same for other attachments. Disconnect any hydraulic lines that are operated by hydraulic power before removing any attachments (breaker, auger, etc.).

WARNING

AVOID INJURY OR DEATH

Never use attachments or buckets which are not approved by Bobcat Company. Buckets and attachments for safe loads of specified densities are approved for each model. Unapproved attachments can cause injury or death.

W-2052-0907

Stop the machine on a flat level surface. Put the bucket on the ground.

Figure OI-98

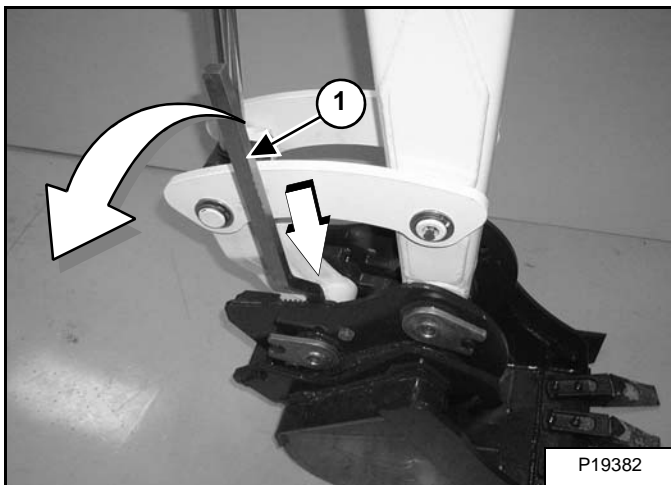

Install the X-Change tool (Item 1) [Figure OI-98] in the latch.

Pull the tool (Item 1) [Figure OI-98] to unlock the latch. Remove the tool.

Figure OI-99

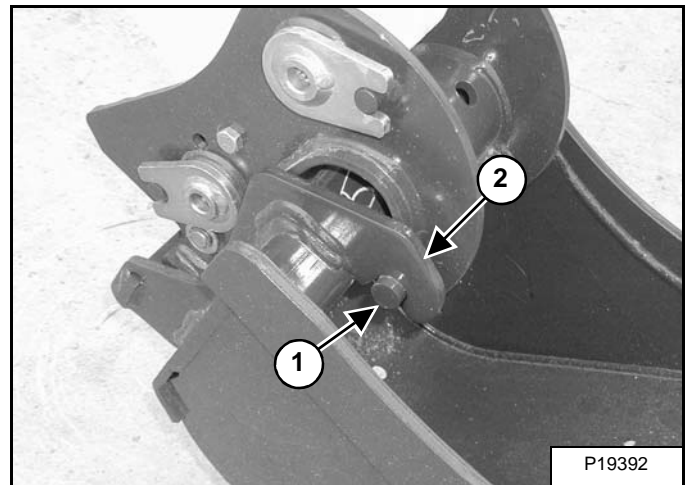

Start the engine, lift the boom approximately one foot and extend the bucket cylinder until the X-Change pins (Item 1) engage the hooks (Item 2) [Figure OI-99] on the bucket.

Figure OI-100

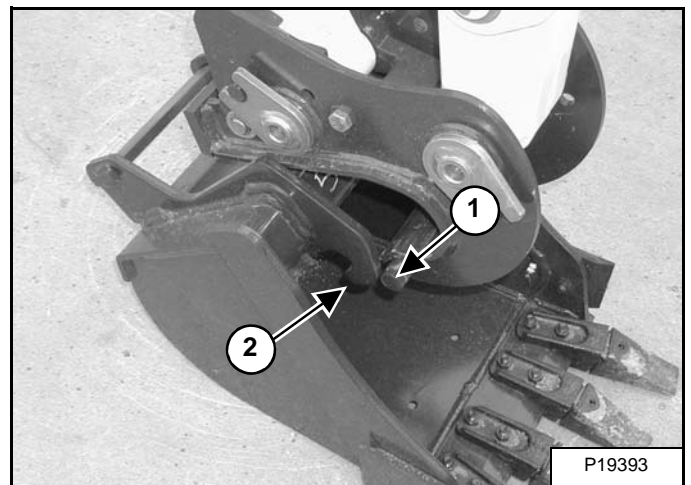

Retract the bucket cylinder and lower the boom and arm until the bucket is on the ground, and the X-Change pins (Item 1) are disengaged from the hooks (Item 2) [Figure OI-100].

Move the arm toward the machine until the X-Change pins are clear of the bucket.

OPERATING PROCEDURE (CONT'D)

Operating In Water

Mud and water should be removed from the machine before parking. In freezing temperatures, park the machine on boards or concrete to prevent the track or undercarriage from freezing to the ground and preventing machine movement.

Figure OI-123

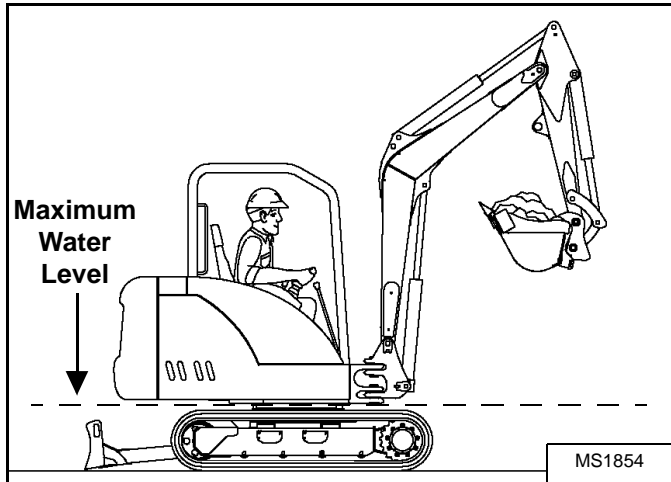

Do not operate or immerse the excavator in water higher than the bottom of the swing bearing [Figure OI-123].

Grease the excavator when it has been operated or immersed in water for a period of time. Greasing forces the water out of the lubrication areas.

Water must be removed from the cylinder rods. If water freezes to the cylinder rod, the cylinder seals can be damaged when the rod is retracted.

Avoiding Track Damage

Mud and water should be removed from the machine before parking. In freezing temperatures, park the machine on boards or concrete to prevent the track or undercarriage from freezing to the ground and preventing machine movement.

TOWING THE EXCAVATOR

Procedure

There is not a recommended towing procedure for the excavators.

- The excavator can be lifted onto the transport vehicle.
- The excavator can be skidded a short distance move for service (EXAMPLE: Move onto a transport vehicle) without damage to the hydraulic system. (The tracks will not turn.) There might be slight wear to the tracks when the excavator is skidded.
- The towing chain (or cable) must be rated at 1 & 1/2 times the weight of the excavator. (See Performance on Page SPEC-6.)

SEAT BELT

Inspection And Maintenance

WARNING

Failure to properly inspect and maintain the seat belt can cause lack of operator restraint resulting in serious injury or death.

W-2466-0703

Check the seat belt daily for correct function.

Inspect the seat belt system thoroughly yearly or more often if the machine is exposed to severe environmental conditions or applications.

The seat belt system should be repaired or replaced if it shows cuts, fraying, extreme or unusual wear, significant discolorations due to ultraviolet (UV) rays from the sun, dusty / dirty conditions, abrasion to the seat belt webbing, or damage to the buckle, latch plate, retractor (if equipped), or hardware.

Figure PM-2

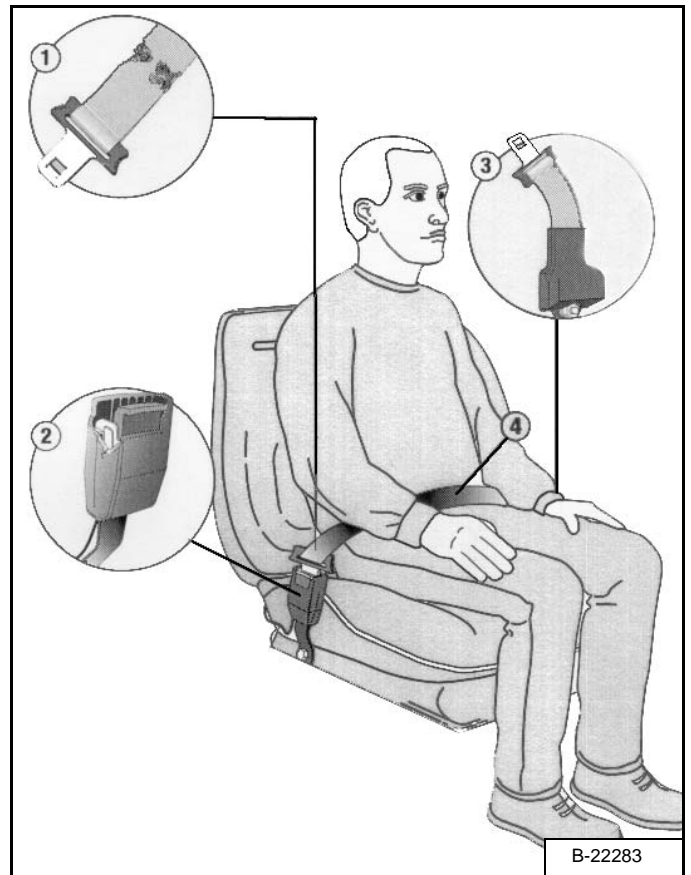

The items below are referenced in [Figure PM-2].

1. Check the seat belt webbing. If the system is equipped with a retractor, pull the webbing completely out and inspect the full length of the webbing. Look for cuts, wear, fraying, dirt and stiffness.
2. Check the buckle and latch for proper function. Make sure latch plate is not excessively worn, deformed or buckle is not damaged.
3. Check the retractor web storage device (if equipped) by extending the seat belt webbing to determine if it extends and retracts the webbing correctly.
4. Check webbing in areas exposed to ultraviolet (UV) rays from the sun or extreme dust or dirt. If the original color of the webbing in these areas is extremely faded and / or the webbing is packed with dirt, the webbing strength may have weakened.

See your Bobcat dealer for approved seat belt system replacement parts for your machine.

HYDRAULIC SYSTEM (CONT'D)

Removing And Replacing The Hydraulic Fluid

See the SERVICE SCHEDULE for the correct service interval. (See SERVICE SCHEDULE on Page PM-5.)

! WARNING

AVOID INJURY OR DEATH

Diesel fuel or hydraulic fluid under pressure can penetrate skin or eyes, causing serious injury or death. Fluid leaks under pressure may not be visible. Use a piece of cardboard or wood to find leaks. Do not use your bare hand. Wear safety goggles. If fluid enters skin or eyes, get immediate medical attention from a physician familiar with this injury.

W-2072-0807

Retract the arm and bucket cylinders, lower the bucket to the ground. Stop the engine.

Open the tailgate.

Figure PM-43

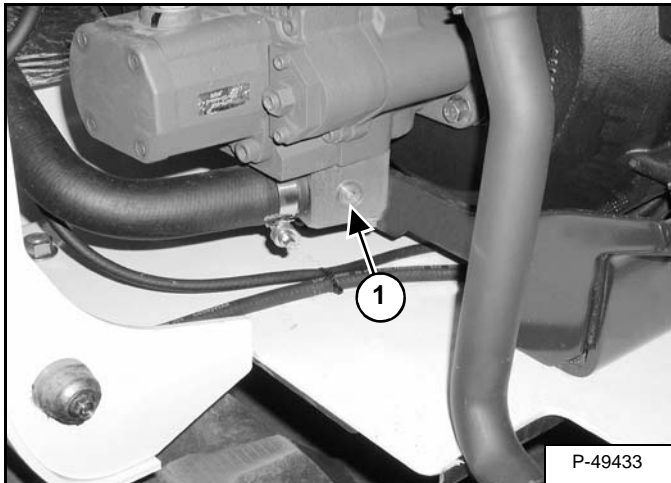

Remove the drain plug (Item 1) [Figure PM-43].

Drain the fluid into a container.

Recycle or dispose of the fluid in an environmentally safe manner.

Install the drain plug (Item 1) [Figure PM-43].

Add the correct fluid to the reservoir until it is visible in the sight gauge. (See Capacities on Page SPEC-9.)

Always replace the filters when changing the hydraulic oil.

Figure PM-44

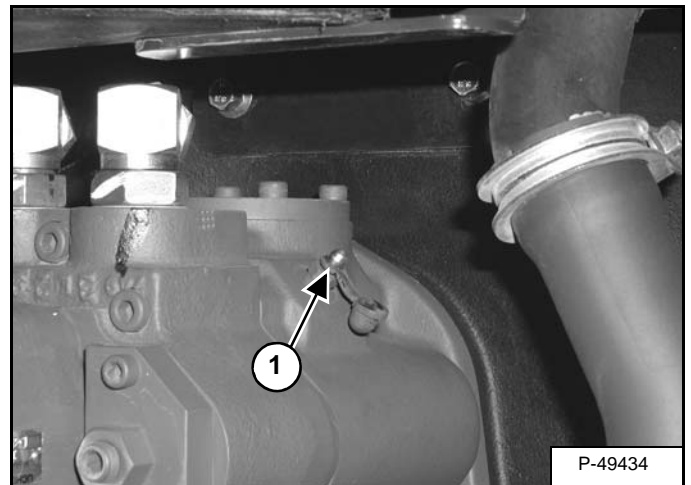
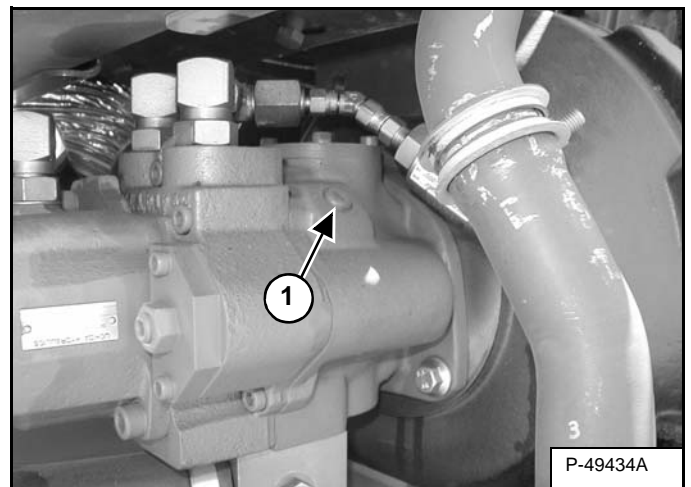

Figure PM-45



After the hydraulic fluid has been drained from the excavator or after the hydraulic pump has been serviced, air must be bled and the hydraulic pump flooded with hydraulic oil. Open the bleed valve (Item 1) (early models) or loosen the plug (Item 1) [Figure PM-45] (later models) on the hydraulic pump. Close the valve or plug after a steady stream of hydraulic fluid free of any air bubbles drains from the valve. Tighten the bleed valve.

DO NOT RUN THE MACHINE WITH THE BLEED VALVE OR PLUG OPEN.

Recycle or dispose of the fluid in an environmentally safe manner.

Start the engine and operate the machine through the hydraulic functions. Stop the engine. Check the fluid level and add as needed.

LUBRICATION OF THE HYDRAULIC EXCAVATOR (CONT'D)

Lubrication Locations (Cont'd)

Figure PM-69

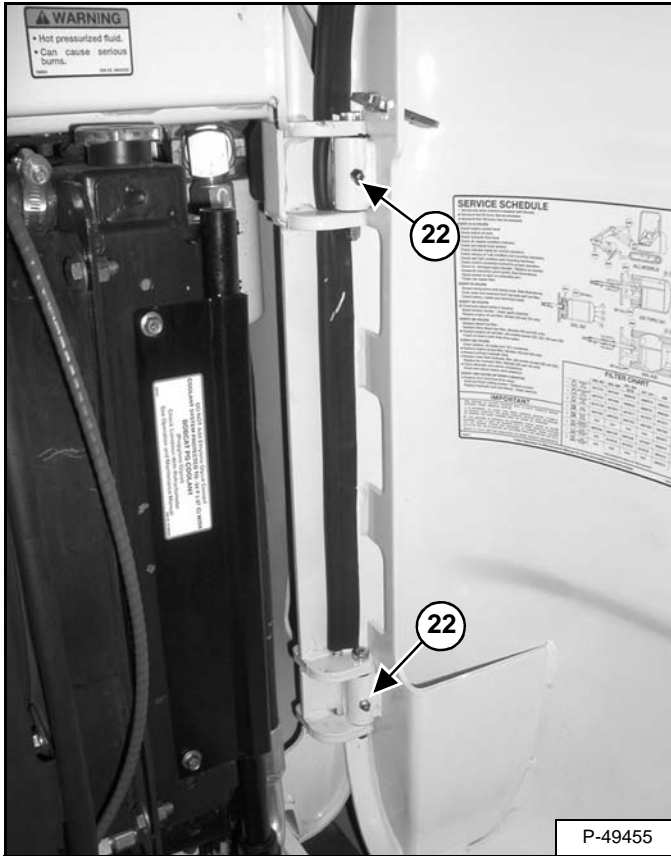

23. Tailgate Hinge (2) [Figure PM-69].

PIVOT PINS

Inspection And Maintenance

Figure PM-70

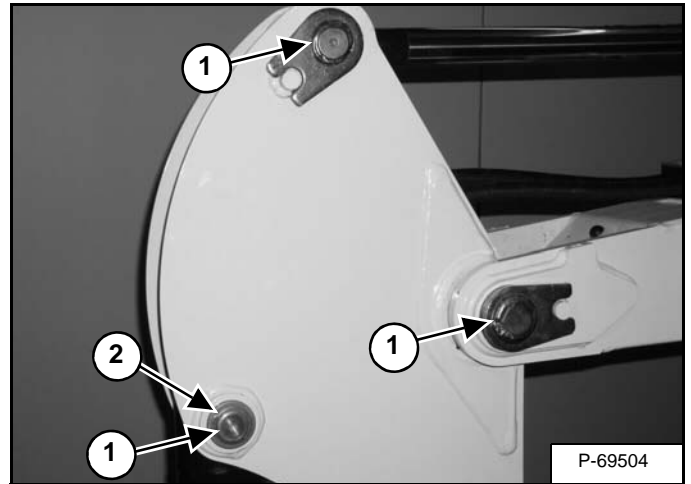

The boom, arm and cylinders pivots (Item 1) have a large pin held in position with a snap ring (Item 2) [Figure PM-68].

Check that the snap rings are securely inserted into the grooves on the pins and that the snap rings are not damaged. See your Bobcat dealer for replacement parts.

⚠ WARNING

Improper loading, transporting and lifting procedures can cause serious injury or death.

TRANSPORTING MACHINE

- Use metal loading ramps with sides and slip resistant surfaces.
- Secure ramps to truck bed.
- Engage truck parking brake and block truck tires.
- Ramp angle must not exceed 15°.
- Top of ramp must be level with truck bed.
- Engage swing lock (if equipped).
- Secure machine with tie downs and block tracks.

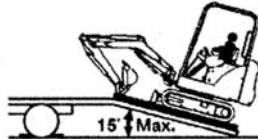

41742

LIFTING MACHINE

- Lifting device must have adequate capacity to lift machine.
- Maintain center of gravity and balance.
- Position machine as shown below. Engage the swing lock (if equipped).
- Never lift with operator on machine.

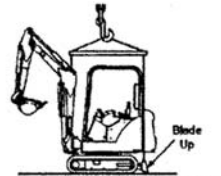

SW 00 6808185

⚠ ADVERTENCIA

Ejecutar procedimientos de carga, transporte y elevación no adecuados puede causar lesiones serias o accidentes fatales.

TRANSPORTE DE LA MÁQUINA

- Utilice rampas de carga metálicas con costados y superficies antideslizantes.
- Asegure las rampas a la plataforma de apoyo del camión.
- Enganche el freno de estacionamiento del camión y bloquee los neumáticos del mismo.
- El ángulo de la rampa no debe exceder los 15°.
- La parte superior de la rampa debe estar nivelada con la plataforma de apoyo del camión.
- Enganche el seguro de giro (si viene equipado).
- Asegure la máquina con amarres y bloquee las orugas.

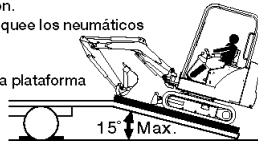

41742

ELEVACIÓN DE LA MÁQUINA

- El dispositivo de elevación debe tener la capacidad adecuada para elevar la máquina.
- Mantenga el centro de gravedad y balance.
- Posicione la máquina como se muestra.
- Enganche el seguro de giro (si viene equipado).
- Jamás eleve con un operador en la máquina.

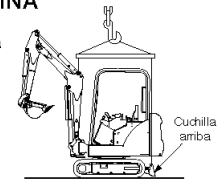

SW 01 6808185 AF

⚠ AVERTISSEMENT

Le non respect des procédures de chargement, de transport et de levage peut causer des blessures graves, voire mortelles.

TRANSPORT DE LA MACHINE

- Utilisez des rampes en acier avec rebords et revêtements anti-dérapants.
- Attachez les rampes au plancher de la remorque.
- Serrez le frein de stationnement et bloquez les roues du camion.
- L'inclinaison de la rampe ne doit pas dépasser 15°.
- L'extrémité de la rampe doit se trouver dans l'alignement du plancher de la remorque.
- Engagez l'axe de verrouillage de l'orientation.
- Attachez la machine avec des chaînes et bloquez les chenilles.

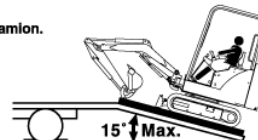



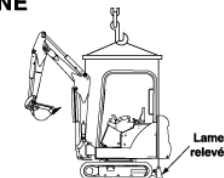

41742

LEVAGE DE LA MACHINE

- Le dispositif de levage doit être capable de supporter le poids de la machine.
- Maintenez le centre de gravité et l'équilibre pendant l'opération.
- Positionnez la machine comme indiqué.
- Engagez l'axe de verrouillage de l'orientation.
- Ne levez jamais la pelle quand l'opérateur s'y trouve.

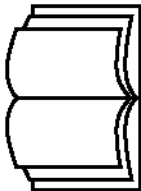
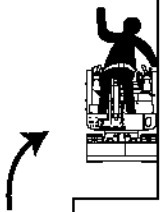

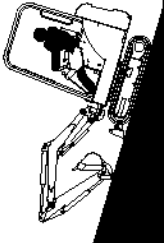
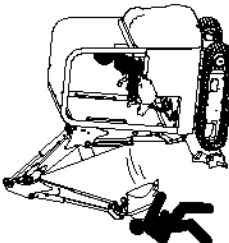
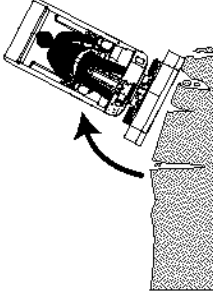
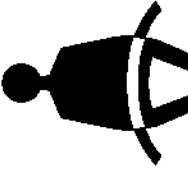
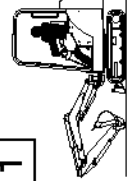
DV-00-6808185-FR

 <h1 style="margin: 0;">WARNING</h1>	
<h2 style="margin: 0;">AVOID INJURY OR DEATH</h2>	
	<p>Never use Excavator without instructions.</p> <p>Read Operation and Maintenance Manual and Handbook.</p>
	<p>Always use cab/canopy.</p> <p>Never modify equipment or use attachments not approved by Bobcat Company.</p>
	<p>Check for overhead or underground lines before operating.</p>
	<p>On slopes, keep heavy end uphill.</p> <p>Do not travel or turn with attachment extended.</p>
	<p>Keep bystanders away.</p> <p>No riders.</p> <p>Check location of blade for direction of travel before moving steering controls.</p>
	<p>Keep away from drop-offs.</p> <p>Avoid steep areas or banks that could break away.</p>
	<p>Fasten seat belt securely.</p> <p>Keep feet and hands on controls.</p> <p>Operate controls only from operator's position.</p> <p>42088</p>
<p>1</p> 	<p>TO LEAVE THE EXCAVATOR:</p> <p>Lower attachment.</p> <p>Never park with tracks pointed down hill.</p>
<p>2</p> 	<p>Stop the engine.</p> <p>Raise control console.</p>
<p>Weitere instruktionen finden sie in der Bedienungsanleitung.</p> <p>Consulte el Manual del Operador por mas instrucciones.</p> <p>Se reporter au manual de l'opérateur pour plus de renseignements.</p> <p style="text-align: right;">SW 01 6807776</p>	

SYSTEME X-CHANGE® A GOUPILLE		SYSTEME X-CHANGE® BOULONNE	
<p>DEPOSE DE L'ACCESSOIRE</p> <ol style="list-style-type: none"> 1. Placez le BRAS EN POSITION VERTICALE, abaissez l'accessoire sur le sol et arrêtez le moteur. 2. Tournez la clé en position ON (MARCHE) (pas en position Start (Démarrage)) et déplacez les deux manipulateurs pour libérer la pression hydraulique. 3. Déposez la goupille de retenue. 4. Déposez la goupille. 5. Démarrez le moteur. Relevez la flèche pour permettre à l'accessoire de tomber sur les crochets. 6. Rétractez complètement le vérin du godet. 7. Abaissez la flèche jusqu'à ce que les axes se désengagent des crochets. 8. Déplacez le bras en direction de l'opérateur. 		<p>DEPOSE DE L'ACCESSOIRE</p> <ol style="list-style-type: none"> 1. Abaissez l'accessoire sur le sol et arrêtez le moteur. 2. Déposez les deux boulons et la plaque. 3. Démarrez le moteur. Relevez la flèche pour permettre à l'accessoire de tomber sur les crochets. 4. Rétractez complètement le vérin du godet. 5. Abaissez la flèche jusqu'à ce que les axes se désengagent des crochets. 6. Déplacez le bras en direction de l'opérateur. 	
<p>INSTALLATION DE L'ACCESSOIRE</p> <ol style="list-style-type: none"> 1. Rétractez complètement le vérin du godet. 2. Engagez les axes dans les crochets. 3. Relevez la flèche et étendez le vérin du godet jusqu'à ce que le X-change entre en contact avec l'arrière de l'accessoire. 4. Abaissez la flèche et l'accessoire sur le sol AVEC LE BRAS VERTICAL jusqu'à ce que le X-change s'engage complètement. 5. Arrêtez le moteur, tournez la clé en position ON (MARCHE) (pas en position Start (Démarrage)) et déplacez les deux manipulateurs pour libérer la pression hydraulique. 6. Installez la goupille. 7. Installez la goupille de retenue. 8. Vérifiez que le montage est correct. Levez l'accessoire et étendez et rétractez complètement le vérin du godet. 		<p>INSTALLATION DE L'ACCESSOIRE</p> <ol style="list-style-type: none"> 1. Rétractez complètement le vérin du godet. 2. Engagez les axes dans les crochets. 3. Relevez la flèche et étendez le vérin du godet jusqu'à ce que le X-change entre en contact avec l'arrière de l'accessoire. 4. Abaissez la flèche et l'accessoire sur le sol AVEC LE BRAS VERTICAL jusqu'à ce que le X-change s'engage complètement. 5. Arrêtez le moteur. 6. Insérez les deux boulons à travers la plaque et serrez-les à un couple de 190 Nm. 7. Vérifiez que le montage est correct. Levez l'accessoire et étendez et rétractez complètement le vérin du godet. 	

59327

SW 04 7102651

VOIR LE MANUEL DE L'OPERATEUR ET D'ENTRETIEN POUR PLUS D'INSTRUCTIONS ET POUR TOUTE UTILISATION AVEC D'AUTRES ACCESSOIRES

SPECIFICATIONS (CONT'D)

Hydraulic System

Pump - Hydraulic	Engine driven, dual outlet variable displacement piston/gear pump
Pump Capacity Gear Pump (One) Piston Pump (Two)	7.03 GPM (26.6 L/min.) 5.23 GPM (19.8 L/min.)
Auxiliary Flow	12.3 GPM (46.6 L/min)
Control Valve	10 spool open center parallel/series
Fluid Type	Bobcat Fluid, Hydraulic/Hydrostatic 6903117 - (2.5 Gal.) 6903118 - (5 Gal.) 6903119 - (55 Gal.)
System Relief Pressure Boom, Boom Swing Bucket, Arm, Auxiliary Blade	2500 PSI (172 bar) 2500 PSI (172 bar) 3820 PSI (263 bar)
Slew Relief Pressure	1700 PSI (117 bar)
Joystick Pressure	428 PSI (30 bar)
Arm Port Relief Base And Rod End	2900 PSI (200 bar)
Boom Port Relief Base End And Rod End	3335 PSI (230 bar)
Bucket Port Relief Base End Rod End	2900 PSI (200 bar) 3335 PSI (230 bar)
Main Hydraulic Filter Bypass	50 PSI (3.5 bar)
Case Drain Filter Bypass	20 PSI (1.4 bar)

Hydraulic Cylinders

Cylinder	Bore	Rod	Stroke
Boom (cushion up)	3.00 in. (76.2 mm)	1.62 in. (41.3 mm)	18.68 in. (423.7 mm)
Arm (cushion retract)	3.00 in. (76.2 mm)	1.5 in. (38.1 mm)	19.11 in. (485.4 mm)
Bucket	2.5 in. (63.5 mm)	1.5 in. (38.1 mm)	18.34 in. (465.8 mm)
Boom Swing (cushion left/right)	2.38 in. (60.3 mm)	1.38 in. (34.9 mm)	15.75 in. (400 mm)
Blade	2.75 in. (69.9 mm)	1.50 in. (38.1 mm)	7.68 in. (195 mm)



Bobcat®

Operation & Maintenance Manual 325 / 328 Compact Excavator

325 - S/N AAC511001 & Above
325 - S/N A9K011001 & Above
328 - S/N A9K111001 & Above

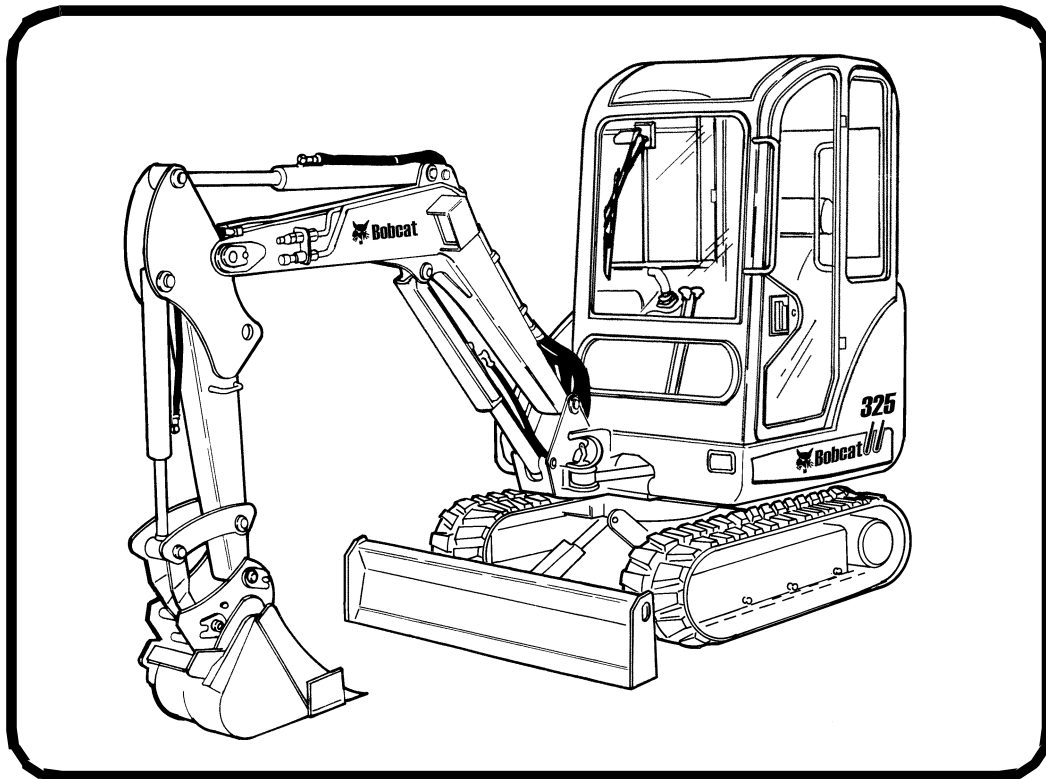

SERIAL NUMBER LOCATIONS

Always use the serial number of the excavator when requesting service information or when ordering parts. Early or later models (identification made by serial number) may use different parts, or it may be necessary to use a different procedure in doing a specific service operation.

Excavator Serial Number

Figure 1

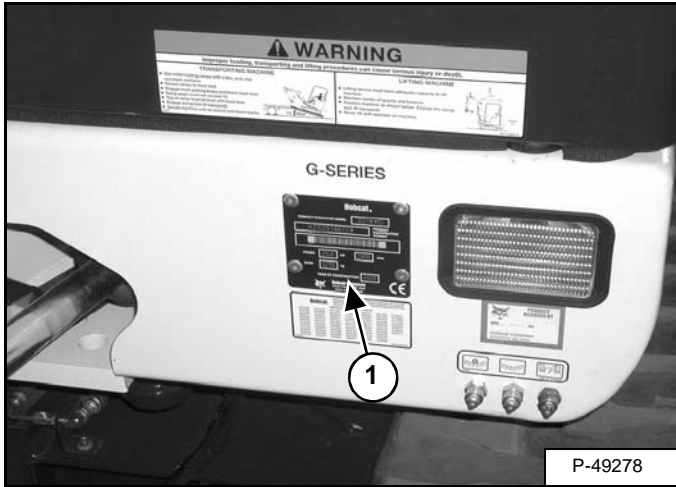

The excavator serial number plate (Item 1) is located on the frame of the machine in the location shown [Figure 1].

Explanation of excavator Serial Number:

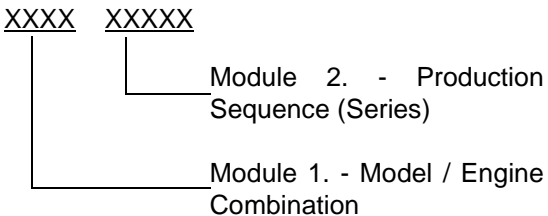

1. The four digit Model / Engine Combination Module number identifies the model number and engine combination.
2. The five digit Production Sequence Number identifies the order which the excavator is produced.

Engine Serial Number

Figure 2

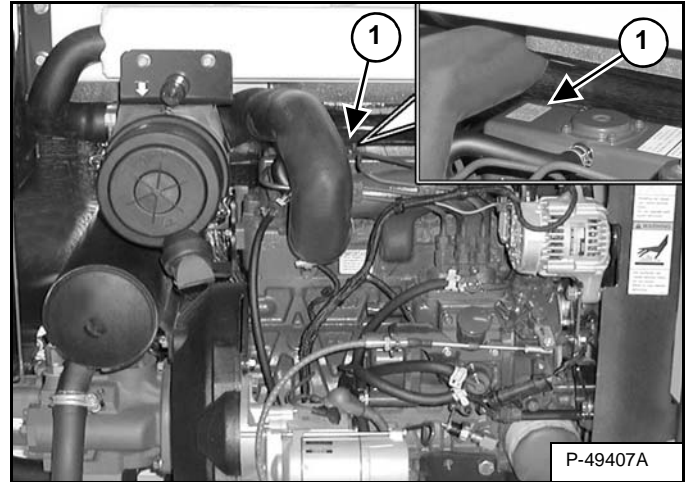

The engine serial number (Item 1) [Figure 2] is located on the engine in the locations shown.

DELIVERY REPORT

Figure 3

The delivery report must be filled out by the dealer and signed by the owner or operator when the Bobcat Excavator is delivered. An explanation of the form must be given to the owner. Make sure it is filled out completely [Figure 3].

MACHINE SIGNS (DECALS)

Follow the instructions on all the Machine Signs (Decals) that are on the excavator. Replace any damaged machine signs and be sure they are in the correct locations. Machine signs are available from your Bobcat Excavator dealer.

6808481

JOYSTICK CONTROL PATTERN SELECTOR LEVER

CONTROL PATTERN A (STD)		CONTROL PATTERN B (ISO)	
LH	RH	LH	RH

6815957

6815945

AUX HYD

6808261

7126509

6808261

OPERATOR'S HANDBOOK

6903819

WARNING

AVOID INJURY OR DEATH

- Know the Control Pattern Before Operating.
- See Operation and Maintenance Manual or Handbook for more information.

B ISO	A STD
-------	-------

6808474

6808433

LEFT CONSOLE AREA

WARNING

AVOID INJURY OR DEATH

Never stand on or near the attachment extended. Lock in the direction of travel.

6809829

X-CHANGE®

P/N 6803193
WEIGHT: 40 kg (89.0 lbs)
MFG BY BOBCAT CO. USA

6803604

UNDERCARRIAGE COMPONENTS

This undercarriage is equipped with rollers and idlers for use with rubber tracks only. Refer to parts manual for components required for use with steel tracks.

6589129(2)

WARNING

HIGH PRESSURE GREASE CAN CAUSE SERIOUS INJURY

- Do not loosen grease fitting.
- Do not loosen bleed fitting more than 1-1/2 turns.

6804114(2)

WARNING

Improper loading, transporting and lifting procedures can cause serious injury or death.

TRANSPORTING MACHINE	LIFTING MACHINE
<ul style="list-style-type: none"> Use metal loading ramps with sides and slip resistant surfaces. Secure machine to truck bed. Engage track parking brake and block truck tires. Tray angle must not exceed 12°. Tip of ramp must be level with truck bed. Engage safety lock (if equipped). Secure machine with the chains and block tracks. 	<ul style="list-style-type: none"> Lifting device must have adequate capacity to lift machine. Maintain center of gravity and balance. Position machine as shown before engaging the swing lock (if equipped). Never lift with operator on machine.

6808185

6808480

6808480

6808872(2)

6808872(2)

6533899 (2)

6533899 (2)

INSTRUMENTS AND CONSOLES (CONT'D)

Raising And Lowering The Console

Raise the console before exiting the cab.

Figure OI-7



Pull up on the release handle [Figure OI-7]. The lift spring will assist in raising the console.

Lower the console before operating the excavator.

Push down on the console [Figure OI-7] until the latch is engaged.

NOTE: When the console is raised, the hydraulic and traction system functions are locked and will not operate.

If the engine stops, the boom / bucket (attachments) can be lowered to the ground using hydraulic pressure in the accumulator.

The control console must be in the locked down position, and the key switch in the ON position.

Two-Speed Travel

Figure OI-8

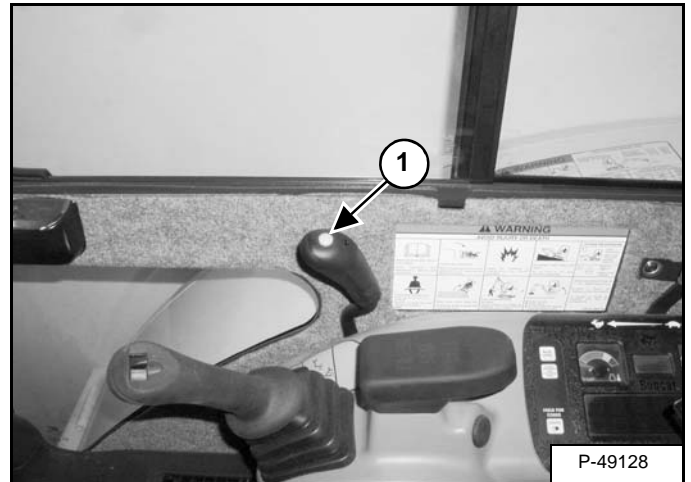
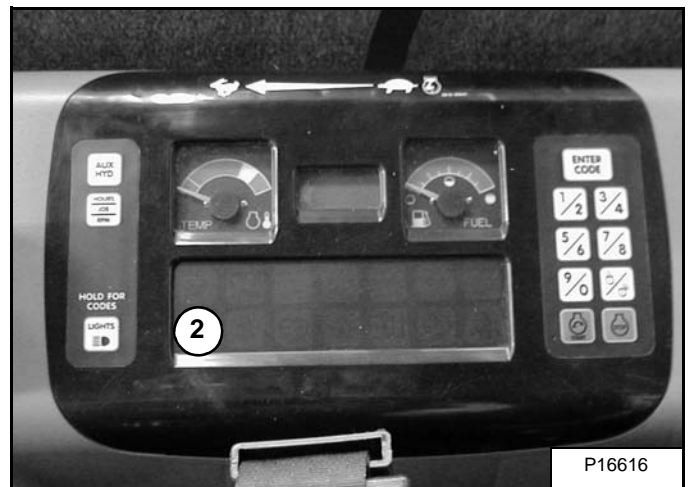

Figure OI-9



Push the button (Item 1) [Figure OI-8] to engage the High Range.

When High Range is engaged, the two speed travel icon (Item 2) [Figure OI-9] will illuminate.

Press the button again to disengage.

HYDRAULIC CONTROLS

Description

The work equipment (boom, arm, bucket, and upperstructure slew) is operated by using the left and right control levers (joysticks). These joysticks can be used in either a STANDARD Control Pattern [Figure OI-33] & [Figure OI-34] or in the ISO Control Pattern [Figure OI-35] & [Figure OI-36].

STANDARD Control Pattern

Left Control Lever (Joystick)

Figure OI-33

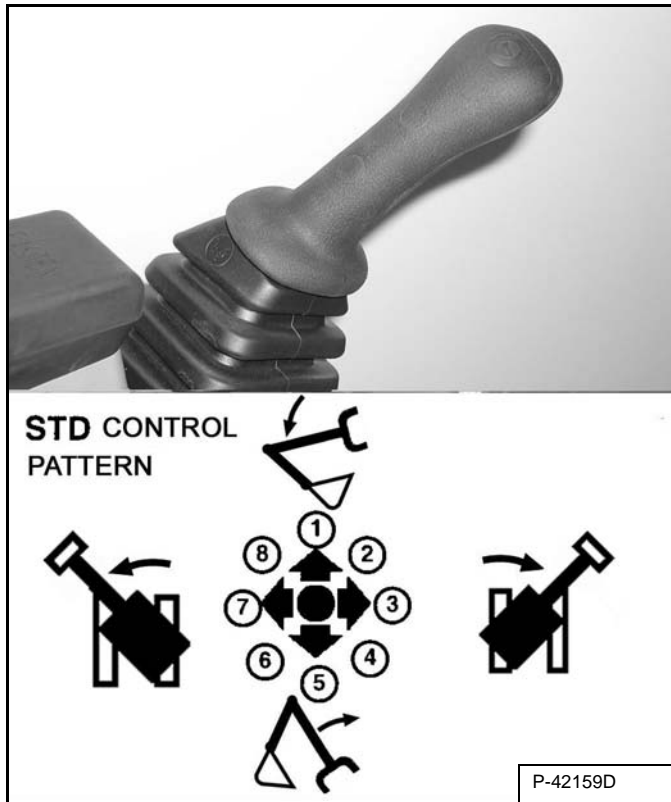

The left lever (joystick) is used to operate the arm and slew the upperstructure [Figure OI-33].

1. Boom lower.
2. Boom lower and slew right.
3. Slew right.
4. Boom raise and slew right.
5. Boom raise.
6. Boom raise and slew left.
7. Slew left.
8. Boom lower and slew left.

IMPORTANT

Before slewing the upperstructure, make sure the slew lock is disengaged.

I-2051-0905

Right Control Lever (Joystick)

Figure OI-34

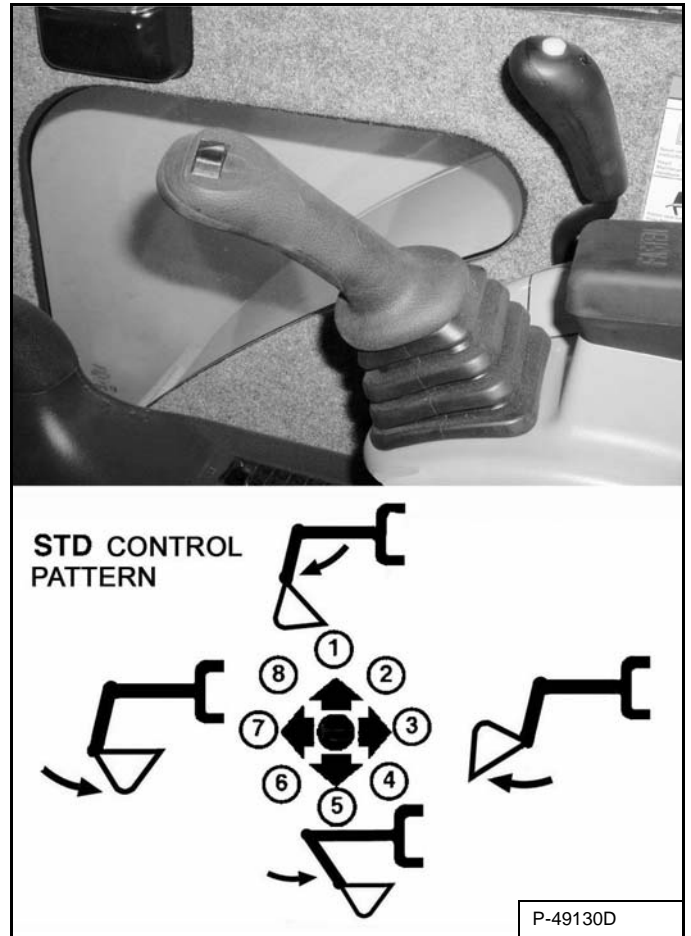

The right lever (joystick) is used to operate the boom and bucket [Figure OI-34].

1. Arm out.
2. Arm out and bucket dump.
3. Bucket dump.
4. Arm in and bucket dump.
5. Arm in.
6. Arm in and bucket curl.
7. Bucket curl.
8. Arm out and bucket curl.

! WARNING

AVOID INJURY OR DEATH

Before leaving the machine:

- Lower the work equipment to the ground.
- Lower the blade to the ground.
- Stop the engine & remove the key.

W-2196-0595

STARTING THE ENGINE (CONT'D)

Keyless



AVOID INJURY OR DEATH

- Fasten seat belt, start and operate only from the operator's seat.
- Never wear loose clothing when working near machine.

W-2135-1108

Perform the PRE-STARTING PROCEDURE. (See PRE-STARTING PROCEDURE on Page OI-24.)

Figure OI-56



Move the engine speed control (Item 1) [Figure OI-56] to low idle.

Figure OI-57

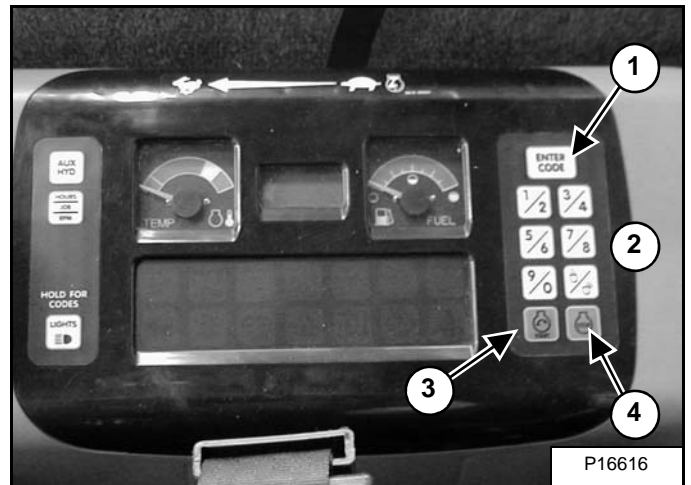

Press ENTER CODE Button (Item 1) [Figure OI-57]. The display will become lighted and there will be two short beeps, CodE will appear on the LCD.

Use the keypad (Item 2) [Figure OI-57] to enter the password. For each digit that you enter, a dash will appear on the LCD. (You have 40 seconds to enter the password or the process will abort and you will need to start over.) If the password was entered correctly, there will be one long beep.

NOTE: If the password was incorrect there will be three short beeps and "Error" will appear on the LCD. Press the ENTER CODE Button again and start over. After three failed attempts, you must wait three minutes to try again.

Press the START Button (Item 3) [Figure OI-57] and hold it until the engine starts.



Do not engage the starter for longer than 15 seconds at a time. Longer use can damage the starter by overheating. Allow starter to cool for one minute before using starter again.

I-2034-0700

Press the STOP button (Item 4) [Figure OI-57] to stop the engine.

Stop the engine if the warning lights and alarm do not go OFF.

Check for the cause before starting the engine again.

Password Lockout Feature

See Password Lockout Feature. (See Password Lockout Feature on Page SA-5.)

ATTACHMENTS (CONT'D)

Installing And Removing The Attachment (Pin-On X-Change) (Cont'd)

Removal (Cont'd)

Figure OI-78

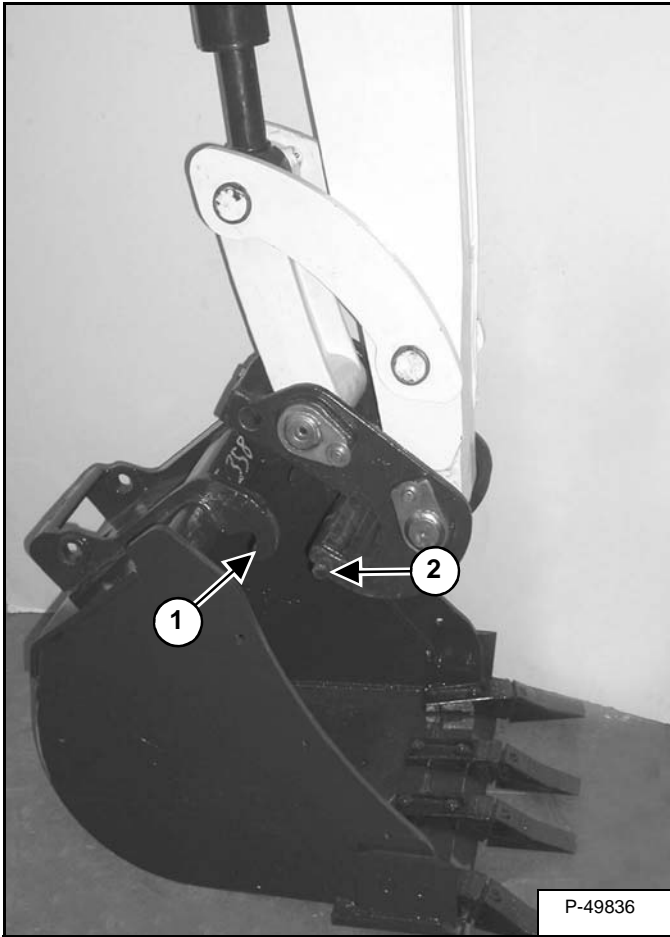

Fully retract the bucket cylinder and lower the boom and arm until the bucket is on the ground, and the X-Change pins (Item 1) are disengaged from the hooks (Item 2) **[Figure OI-78]**.

Move the arm toward the excavator until the X-Change pins are clear of the bucket.

OPERATING PROCEDURE (CONT'D)

Excavating

Lower the blade to provide stability.

Figure OI-97

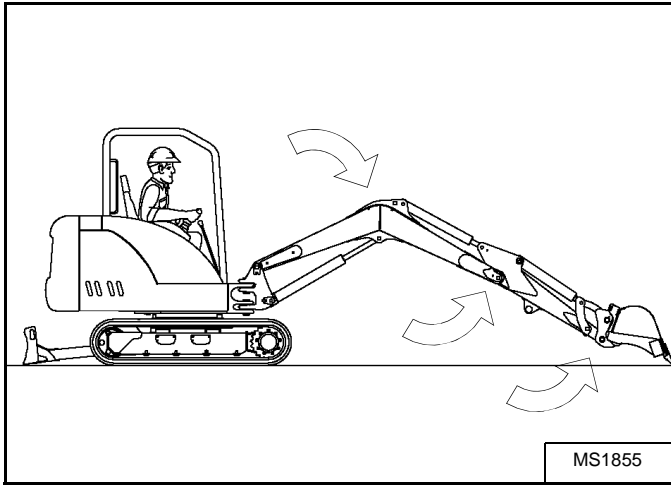

Extend the arm, lower the boom, and open the bucket [Figure OI-97].

Figure OI-98

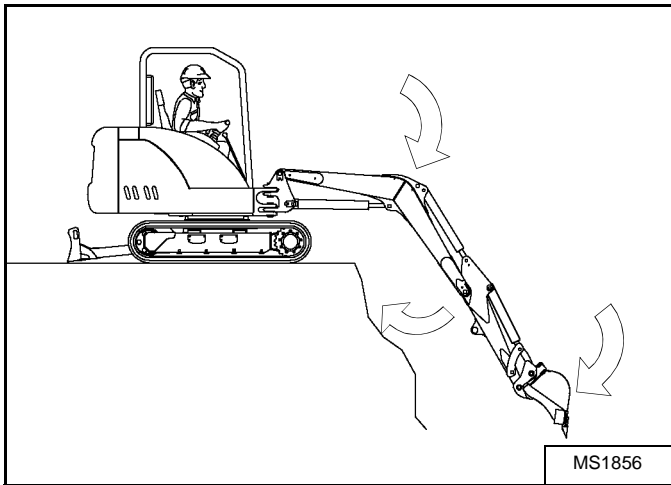

Retract the arm, while lowering boom and curling the bucket [Figure OI-98].

Figure OI-99

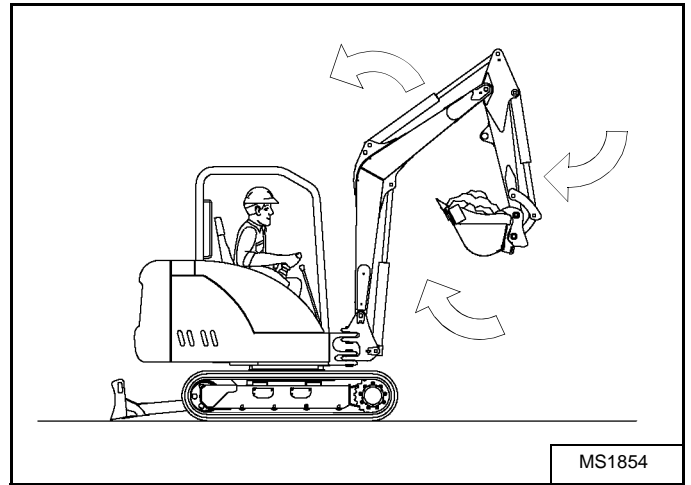

Raise the boom, retract the arm and curl the bucket [Figure OI-99].

Rotate the upperstructure.

NOTE: Do not allow the bucket teeth to contact the ground when swinging the upperstructure.

! WARNING

Keep all bystanders 20 feet (6 m) away from equipment when operating. Contact with moving parts, a trench cave-in or flying objects can cause injury or death.

W-2119-0788

! WARNING

AVOID INJURY OR DEATH

Check area to be excavated for overhead or underground electrical power lines. Keep a safe distance from electrical power lines.

LINE VOLTAGE	MINIMUM APPROACH DISTANCE
50 kV	At least 10 ft. (3m)
230 kV	At least 16 ft. (5m)
740 kV	At least 33 ft. (10m)

W-2757-0908

TRANSPORTING THE EXCAVATOR ON A TRAILER

Loading And Unloading

When transporting the machine, observe the rules, motor vehicle laws, and vehicle limit ordinances. Use a transport and towing vehicle of adequate length and capacity.

Secure the parking brakes and block the wheels of the transport vehicle.

Align the ramps with the center of the transport vehicle. Secure the ramps to the truck bed and be sure ramp angle does not exceed 15 degrees.

Use metal loading ramps with a slip resistant surface.

Use ramps that are the correct length and width and can support the weight of the machine.

The rear of the trailer must be blocked or supported when loading or unloading the excavator to prevent the front of the transport vehicle from raising.

Determine the direction of the track movement before moving the machine (blade forward).

Engage the slew lock.

Figure OI-122



Move the machine forward onto the transport vehicle [Figure OI-122].

Do not change direction of the machine while it is on the ramps.

Lower the boom, arm, bucket, and blade to the transport vehicle.

Stop the engine and remove the key (if equipped).

Put blocks at the front and rear of the tracks.

Fastening

Figure OI-123

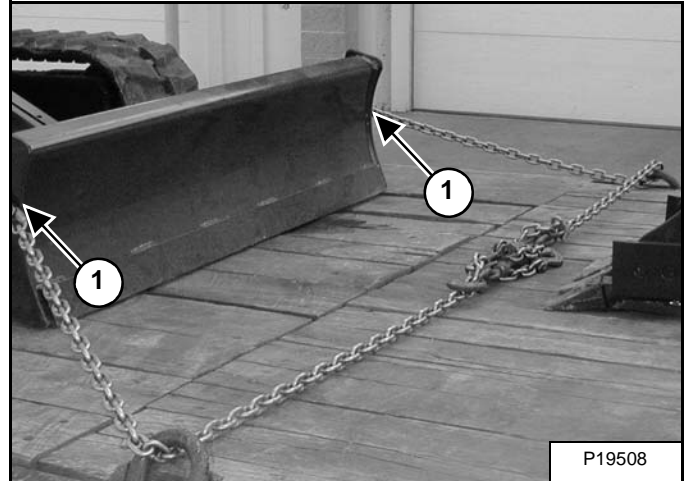
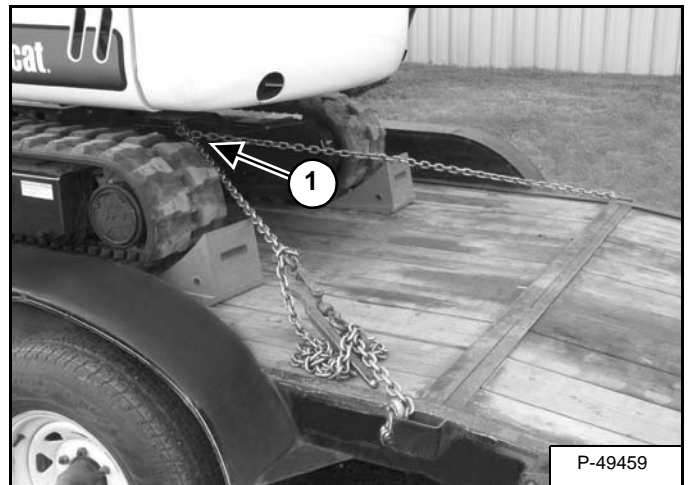

Figure OI-124



Fasten chains to the front corners of the blade (Item 1) [Figure OI-123] and to the tie down loop at the rear of the track frame (Item 1) [Figure OI-124] to prevent it from moving when going up or down slopes or during sudden stops.

Use chain binders to tighten the chains and then safely tie the chain binder levers to prevent loosening.

! WARNING

AVOID SERIOUS INJURY OR DEATH
Adequately designed ramps of sufficient strength are needed to support the weight of the machine when loading onto a transport vehicle. Wood ramps can break and cause personal injury.

W-2058-0807

TAILGATE

Opening And Closing



AVOID INJURY OR DEATH

Never service or adjust the machine when the engine is running unless instructed to do so in the manual.

W-2012-0497



Keep the rear door closed when operating the machine. Failure to do so could seriously injure a bystander.

W-2020-1285

Figure PM-7

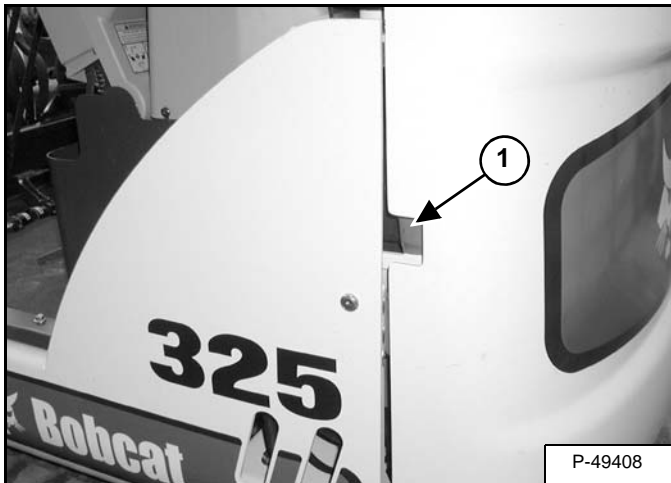

Pull the latch (Item 1) [Figure PM-7] and pull the tailgate open.

Push firmly to close the tailgate.

NOTE: The tailgate can be locked using the start key.

Adjusting The Bumper

Figure PM-8

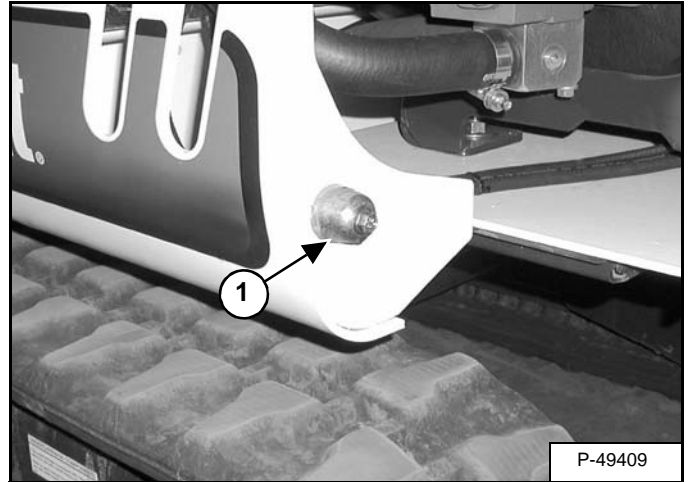

The door bumper (Item 1) [Figure PM-8] can be adjusted for alignment with the tailgate.

Close the tailgate before operating the excavator.

Adjusting The Latch

Figure PM-9

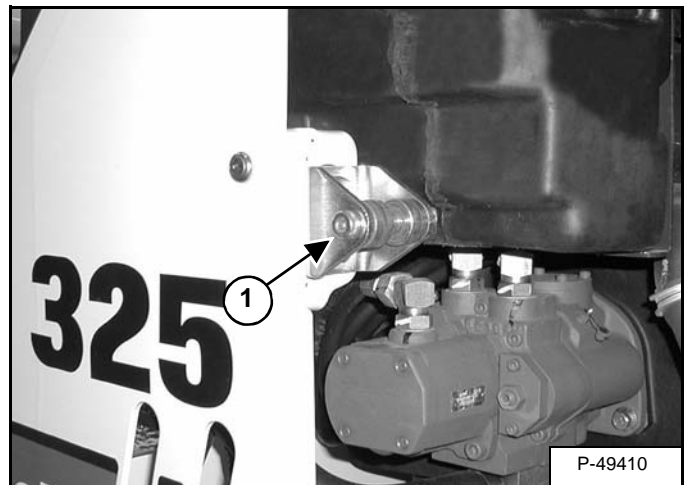

The door catch (Item 1) [Figure PM-9] can be adjusted for alignment.

Close the tailgate before operating the excavator.

ENGINE LUBRICATION SYSTEM (CONT'D)

Removing And Replacing Oil And Filter

See the SERVICE SCHEDULE for the service interval for replacing the engine oil and filter. (See SERVICE SCHEDULE on Page PM-5.)

Run the engine until it is at operating temperature. Stop the engine.

Open the tailgate.

Figure PM-25

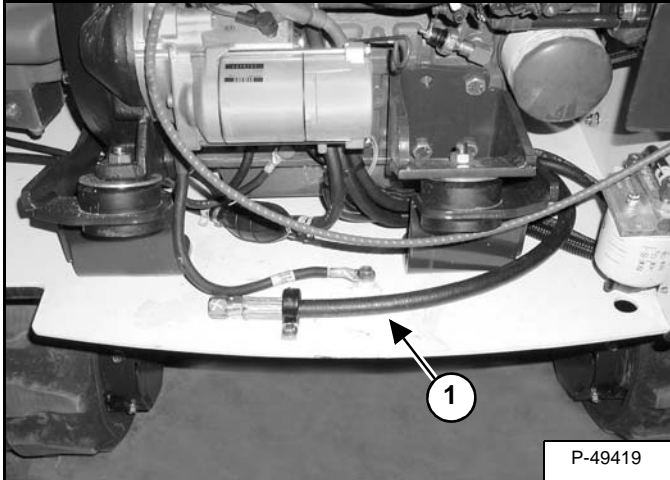

Route the drain hose (Item 1) [Figure PM-25] out the tailgate.

Figure PM-26

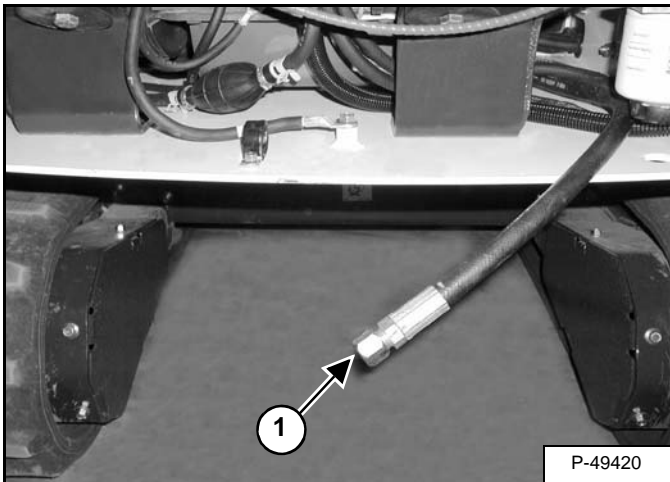

Remove the cap (Item 1) [Figure PM-26]. Drain the oil into a container.

Recycle or dispose of used oil in an environmentally safe manner.

Figure PM-27

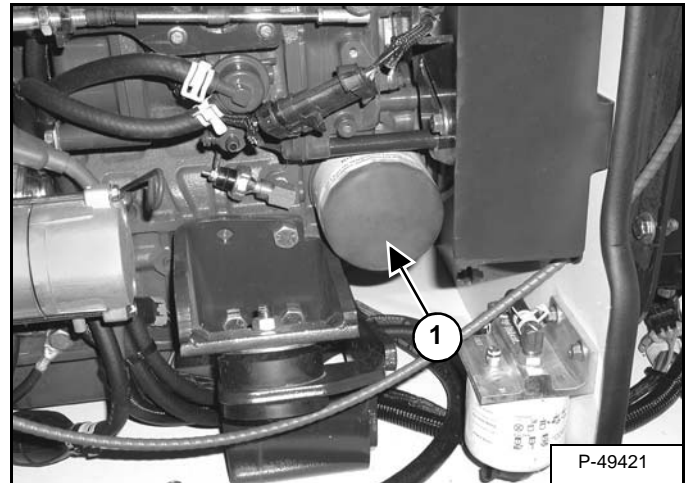

Remove the oil filter (Item 1) [Figure PM-27] and clean the filter housing surface.

Use a genuine Bobcat replacement filter. Put clean oil on the filter gasket. Install the filter and hand tighten.

Install and tighten the oil cap.

HYDRAULIC SYSTEM (CONT'D)

Removing And Replacing The Hydraulic Fluid

See the SERVICE SCHEDULE for the correct service interval. (See SERVICE SCHEDULE on Page PM-5.)

WARNING

AVOID INJURY OR DEATH

Diesel fuel or hydraulic fluid under pressure can penetrate skin or eyes, causing serious injury or death. Fluid leaks under pressure may not be visible. Use a piece of cardboard or wood to find leaks. Do not use your bare hand. Wear safety goggles. If fluid enters skin or eyes, get immediate medical attention from a physician familiar with this injury.

W-2072-0807

Retract the arm and bucket cylinders, lower the bucket to the ground. Stop the engine.

Open the tailgate.

Figure PM-45

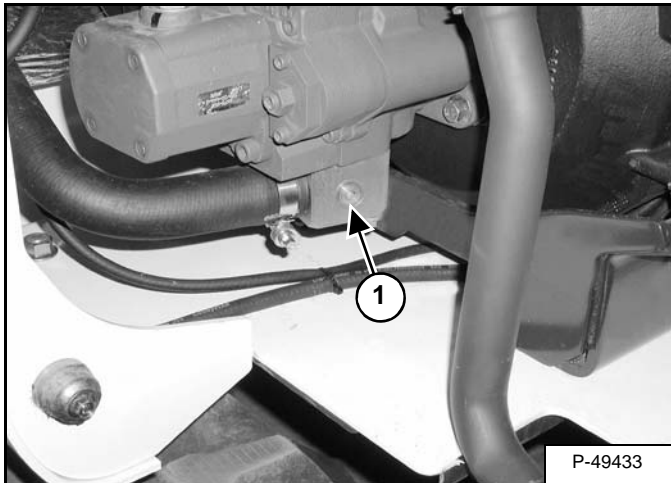

Remove the drain plug (Item 1) [Figure PM-45].

Drain the fluid into a container.

Recycle or dispose of the fluid in an environmentally safe manner.

Install the drain plug (Item 1) [Figure PM-45].

Add the correct fluid to the reservoir until it is visible in the sight gauge. (See Capacities on Page SPEC-9.)

Always replace the filters when changing the hydraulic oil.

Figure PM-46

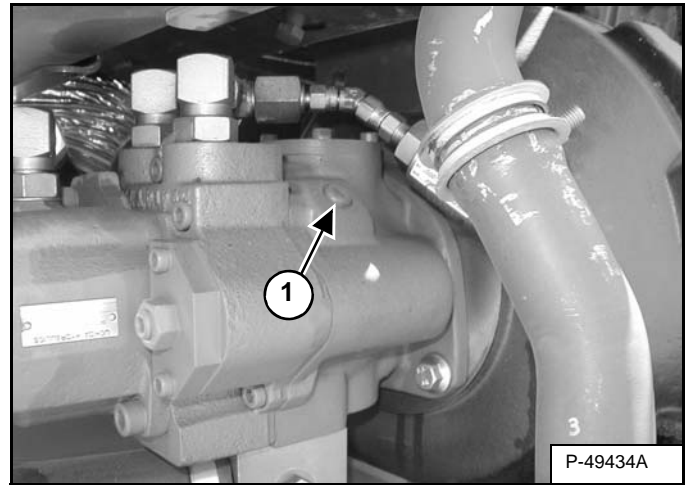

After the hydraulic fluid has been drained from the excavator or after the hydraulic pump has been serviced, air must be bled and the hydraulic pump flooded with hydraulic oil. Loosen the plug (Item 1) [Figure PM-46] on the hydraulic pump. Tighten the plug after a steady stream of hydraulic fluid free of any air bubbles drains from the valve.

DO NOT RUN THE MACHINE WITH THE BLEED VALVE OR PLUG OPEN.

Recycle or dispose of the fluid in an environmentally safe manner.

Start the engine and operate the machine through the hydraulic functions. Stop the engine. Check the fluid level and add as needed.

LUBRICATION OF THE HYDRAULIC EXCAVATOR (CONT'D)

Lubrication Locations (Cont'd)

Figure PM-67

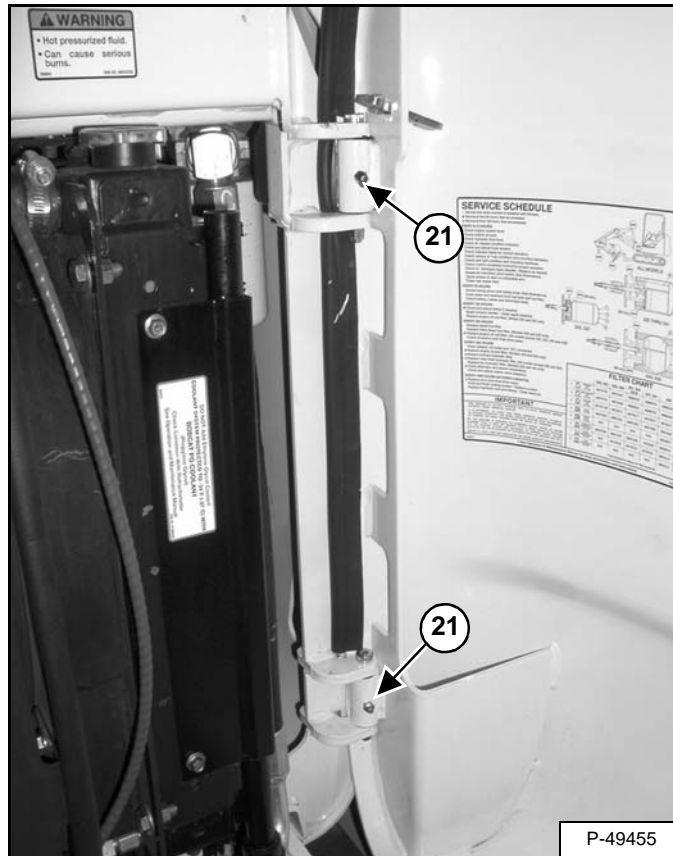

21. Tailgate Hinge (2) [Figure PM-67].

PIVOT PINS

Inspection And Maintenance

Figure PM-68

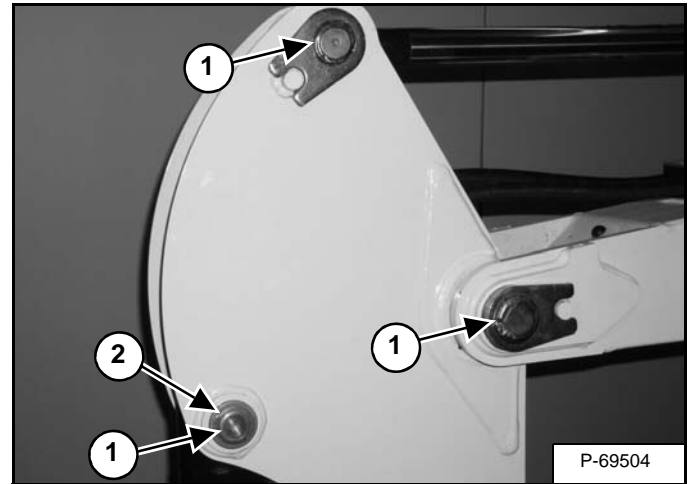

The boom, arm and cylinders pivots (Item 1) have a large pin held in position with a snap ring (Item 2) [Figure PM-68].

Check that the snap rings are securely inserted into the grooves on the pins and that the snap rings are not damaged. See your Bobcat dealer for replacement parts.

MACHINE SIGN TRANSLATIONS

JOYSTICK CONTROL PATTERN SELECTOR LEVER (6815957)	MST-23
LIFT CHART	MST-4
325 (6809677)	MST-4
325 W/ Long Arm And 328 (6809678)	MST-7
SERVICE SCHEDULE (7158257)	MST-10
USING THE X-CHANGE SYSTEM (7102651)	MST-19
WARNING(6804114)	MST-16
WARNING (6807776)	MST-13
WARNING (6808185)	MST-3
WARNING (6809829)	MST-22
WARNING (6815915)	MST-18
WARNING (6817815)	MST-17
WARNING (6804232)	MST-16
WARNING (6577754)	MST-16
WARNING (6804233)	MST-16
WARNING 6808474)	MST-17

**MACHINE SIGN
TRANSLATIONS
(MST)**

PERIODICITE DES ENTRETIENS

- * Seulement si la machine est équipée de cet élément.
- Après 50 heures d'utilisation puis selon périodicité.
- ▲ Après 100 heures d'utilisation puis selon périodicité.

TOUTES LES 8-10 HEURES

- Contrôler le niveau du réfrigérant moteur.
- Contrôler le niveau d'huile moteur.
- Contrôler le niveau d'huile hydraulique.
- Contrôler l'indicateur d'état du filtre à air.
- Contrôler et régler la tension des chenilles.
- Contrôler le fonctionnement d'après les témoins indicateurs.
- Contrôler l'état du déflecteur ou de la cabine et de leurs fixations.
- Contrôler l'état de la ceinture de sécurité et de ses fixations.
- Contrôler le fonctionnement du verrouillage des pupitres de commande.
- Contrôler l'état des autocollants - Remplacer si nécessaire.
- Lubrifier tous les points pivots de la machine (voir illustrations).
- * Appliquer de la graisse sur la glissière du bras extensible.
- * Nettoyer le filtre du chauffage de la cabine.

TOUTES LES 50 HEURES

- Lubrifier le pignon et la couronne d'oscillation (voir illustrations).
- Purger l'eau et les dépôts du réservoir de carburant et du filtre d'alimentation.
- Contrôler la batterie, ses câbles et son niveau d'électrolyte.

TOUTES LES 100 HEURES

- Contrôler les courroies et les régler si nécessaire (modèles 320, 322, 325 et 328).
- Silencieux pare-étincelles - Nettoyer la chambre à étincelles.
- Remplacer l'huile moteur et le filtre à huile (modèles 320 et 322).

TOUTES LES 250 HEURES

- Remplacer le filtre à carburant diesel.
- Remplacer le filtre de l'alimentation en carburant diesel (modèles 430 et 435 uniquement).
- Remplacer l'huile moteur et le filtre (modèles 325 et 328 uniquement).
- Contrôler le niveau d'huile dans les deux carters de chaînes finaux.

TOUTES LES 500 HEURES

- Remplacer l'huile moteur et le filtre (modèles 331, 334, 331E, 337, 341, 430 et 435).
- Nettoyer le radiateur, le refroidisseur d'huile et le condensateur de climatisation.
- ▲ Contrôler et régler les courroies et les galets d'entraînement.
- Remplacer si nécessaire (modèles 331, 331E, 334, 337, 341, 430 et 435).
- ▲ Remplacer le filtre du circuit hydraulique primaire.
- ▲ Remplacer le filtre hydraulique du retour de carter (tous modèles sauf 320 et 322).
- Remplacer le filtre hydraulique du ventilateur (modèles 430 et 435).
- ▲ Contrôler les connexions de l'alternateur et du démarreur.
- Contrôler et régler le jeu des soupapes du moteur.

TOUTES LES 1000 HEURES OU TOUTS LES 6 MOIS

- ▲ Remplacer l'huile dans les deux carters de chaînes finaux.
- Vidanger et purger le circuit de refroidissement - Remplacer le réfrigérant.
- Remplacer l'huile et les filtres hydrauliques - Nettoyer le réservoir.

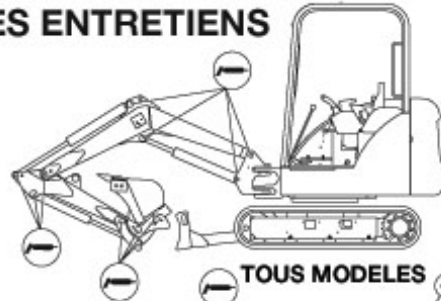

TOUTS MODELES

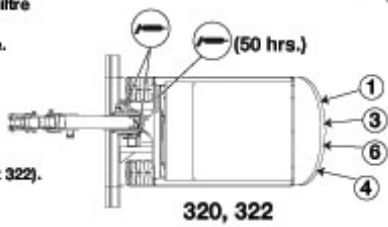

320, 322

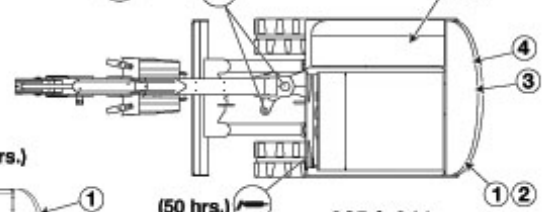

325 à 341

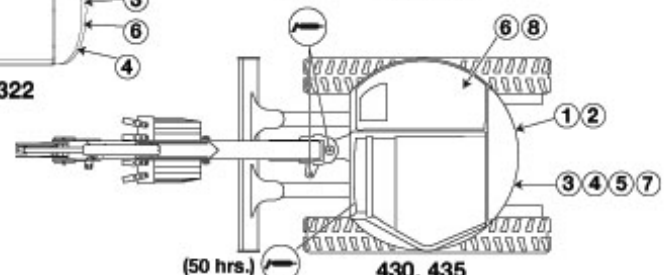

430, 435

IMPORTANT

CETTE MACHINE EST EQUIPEE EN USINE D'UN SILENCIEUX PARE-ETINCELLES APPROUVE PAR LE DEPARTEMENT AMERICAIN DES EAUX ET FORETS.

CE SILENCIEUX PARE-ETINCELLES DOIT ETRE NETTOYE POUR EN MAINTENIR LE BON FONCTIONNEMENT. L'ENTRETIEN DU SILENCIEUX PARE-ETINCELLES CONSISTE A JETER LA CHAMBRE A ETINCELLES TOUTES LES 100 HEURES D'UTILISATION.

SI CETTE MACHINE EST UTILISEE SUR DES TERRAINS COUVERTS DE FORETS, BROUSSAILLES OU HERBES INFLAMMABLES, SON CIRCUIT D'ECHAPPEMENT DOIT ETRE EQUIPE D'UN SILENCIEUX PARE-ETINCELLES MAINTENU EN SON ETAT DE FONCTIONNEMENT. LE NON RESPECT DE CETTE OBLIGATION SERAIT CONTRAIRE A LA LOI DE L'ETAT DE CALIFORNIE, SECTION 4442, PRC.

VEUILLEZ VOUS REFERER AUX LOIS ET REGLEMENTATIONS LOCALES POUR LES EXIGENCES CONCERNANT LES DISPOSITIFS PARE-ETINCELLES.

TABLEAU DES FILTRES

	320, 322	325, 328	331, 334 331E	337, 341	430	435
1. FILTRE A AIR PRIMAIRE	6673752	6672467	6666333	6666375	6666333	6666375
2. FILTRE A AIR SECONDAIRE	6673753	6672468	6666334	6666376	6666334	6666376
3. FILTRE A HUILE MOTEUR	3974113B	6675517	6675517	6675517	6675517	6675517
4. FILTRE D'ALIMENTATION	6667352	6667352	6667352	6667352	6667362	6667362
5. FILTRE	N/A	N/A	N/A	N/A	6633977	6633977
6. FILTRE HYDRAULIQUE PRELIMINAIRE	6653336	6661248	6661248	6670207	6668819	6668819
7. FILTRE HYDRAULIQUE RETOUR CARTER	N/A	6516722	6516722	6516722	6681012	6681012
8. FILTRE HYDRAULIQUE VENTILATEUR	N/A	N/A	N/A	N/A	6681012	6681012

* Voir illustrations ci-dessus pour les emplacements des filtres.

SISTEMA X-CHANGE FIJADO CON PASADOR		SISTEMA X-CHANGE FUADO CON PERNOS	
<p>DESINSTALACIÓN DE IMPLEMENTO</p> <ol style="list-style-type: none"> 1. Coloque el BRAZO en posición VERTICAL, descienda el implemento hasta el suelo y detenga el motor. 2. Gire la llave a ON (no encienda el motor) y mueva ambos joysticks para liberar la presión hidráulica. 3. Retire el pin de retención. 4. Retire el pasador. 5. Encienda el motor. Eleve el "boom" para desenganchar el implemento. 6. Retraiga del todo el cilindro del cucharón. 7. Baje el "boom" hasta que los pines se liberen de los ganchos. 8. Mueva el brazo hacia el operador. 		<p>DESINSTALACIÓN DE IMPLEMENTO</p> <ol style="list-style-type: none"> 1. Descienda el implemento hasta el suelo y detenga el motor. 2. Retire los dos pernos y la placa. 3. Encienda el motor. Eleve el "boom" para liberar el implemento. 4. Retraiga del todo el cilindro del cucharón. 5. Baje el "boom" hasta que los pines se liberen de los ganchos. 6. Mueva el brazo hacia adentro. 	
<p>INSTALACIÓN DE IMPLEMENTO</p> <ol style="list-style-type: none"> 1. Retraiga del todo el cilindro del cucharón. 2. Coloque los pines en los ganchos. 3. Eleve el "boom" y extienda el cilindro del cucharón hasta que el X-Change haga contacto con el espaldar del implemento. 4. Descienda el "boom" e implemento hasta el suelo CON EL BRAZO VERTICAL hasta que el X-Change esté enganchado del todo. 5. Detenga el motor; gire la llave a ON (no encienda el motor) y mueva ambos joysticks para liberar la presión hidráulica. 6. Instale el pasador. 7. Instale el pin de retención. 8. Revise que la instalación sea correcta. Eleve el implemento, y extienda y retraiga del todo el cilindro del cucharón. <p>59327</p>		<p>INSTALACIÓN DE IMPLEMENTO</p> <ol style="list-style-type: none"> 1. Retraiga del todo el cilindro del cucharón. 2. Coloque los pines en los ganchos. 3. Eleve el "boom" y extienda el cilindro del cucharón hasta que el X-Change haga contacto con el espaldar del implemento. 4. Baje el "boom" e implemento hasta el suelo CON EL BRAZO VERTICAL hasta que el X-Change se enganche del todo. 5. Detenga el motor. 6. Inserte dos pernos a través de la placa y apriete a un torque de 140 lbs-pies (190 N-m). 7. Revise que la instalación sea correcta. Eleve el implemento, y extienda y retraiga del todo el cilindro del cucharón. 	
<p>VER EL MANUAL DE OPERACIÓN Y MANTENIMIENTO PARA MAYORES INSTRUCCIONES Y USOS CON OTROS IMPLEMENTOS.</p>			

SW 04 7102651 AR

CLICK HERE TO **DOWNLOAD** THE COMPLETE MANUAL

- Thank you very much for reading the preview of the manual.
- You can download the complete manual from: www.heydownloads.com by clicking the link below



- Please note: If there is no response to CLICKING the link, please download this PDF first and then click on it.

CLICK HERE TO **DOWNLOAD** THE COMPLETE MANUAL