

X 320

Excavator

Operation & Maintenance Manual

(S/N 511720001–511721115)

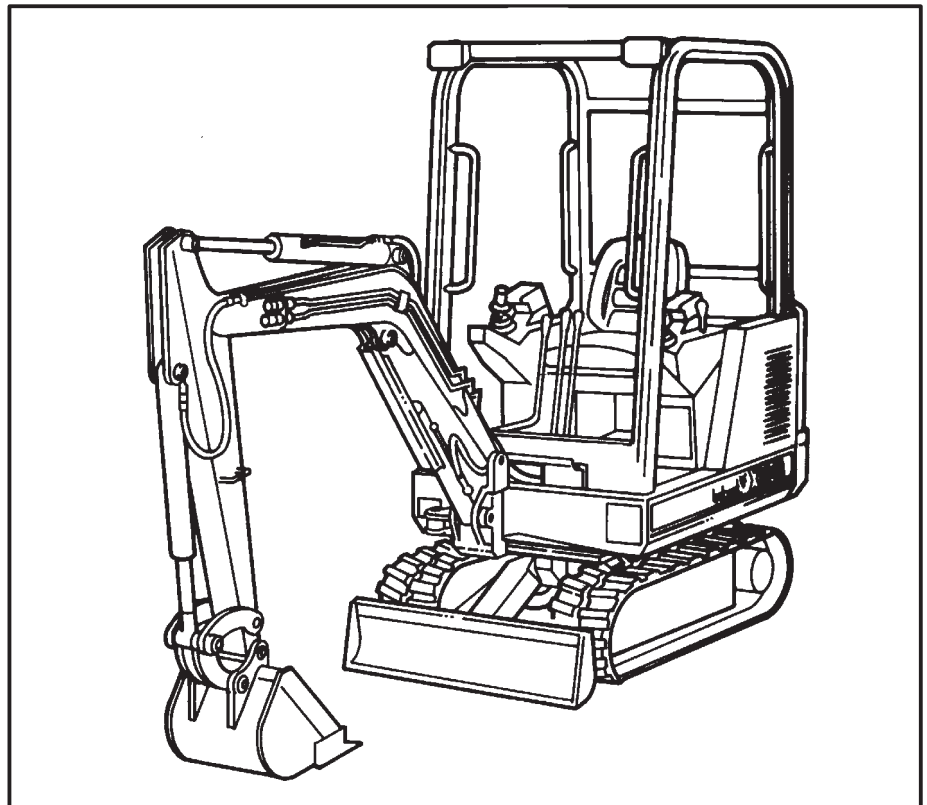

Doosan purchased Bobcat Company from Ingersoll-Rand Company in 2007. Any reference to Ingersoll-Rand Company or use of trademarks, service marks, logos, or other proprietary identifying marks belonging to Ingersoll-Rand Company in this manual is historical or nominative in nature, and is not meant to suggest a current affiliation between Ingersoll-Rand Company and Bobcat Company or the products of either.

MELROE
INGERSOLL-RAND

6722640(2-97) Revised (5-12)

Printed in U.S.A.

 **bobcat**[®]

© Melroe Company 1997

CLICK HERE TO **DOWNLOAD** THE COMPLETE MANUAL

- Thank you very much for reading the preview of the manual.
- You can download the complete manual from: www.heydownloads.com by clicking the link below



- Please note: If there is no response to CLICKING the link, please download this PDF first and then click on it.

CLICK HERE TO **DOWNLOAD** THE COMPLETE MANUAL

SAFETY

SAFETY INSTRUCTIONS	ix, x
FIRE PREVENTION	xi
MACHINE SIGNS (DECALS)	xii, xiii

SAFETY

GETTING ON AND OFF THE MACHINE

Use the grab handles, the tracks and the safety treads to get on and off the machine [A].



Fasten the seat belt snugly Adjust the seat belt so that the buckle is centered between your hips [B].



Lower the control console(s) before starting the engine [C]. (See *STARTING THE ENGINE*, Page 14).



Pull the lever (Item 1) [D] to the rear to release and raise the control console.

NOTE: On Excavators equipped with ROPS canopy, both the left and right control consoles can be raised for operator access. On Excavators with enclosed cab, only the left control console can be raised.

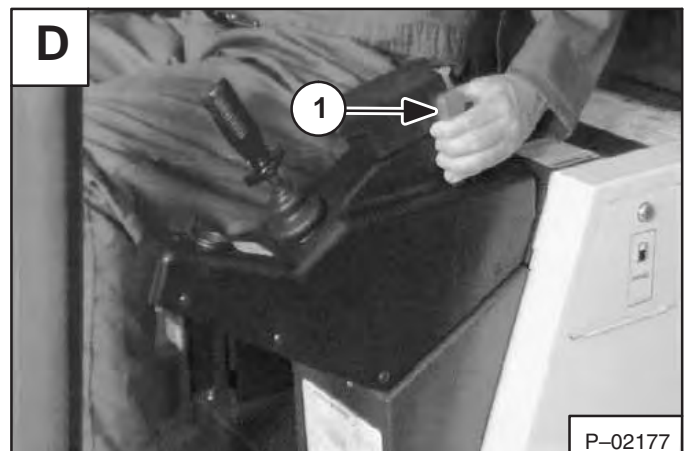

BOOM SWING PEDAL (AND LOCK/FOOT REST)

Raise the pedal lock/foot rest (Item 1) [A] to operate the boom swing pedal.

Push the pedal (Item 2) [A] on the right side to swing the boom to the right and push the pedal on the left side to swing the boom to the left.

NOTE: The purpose of the boom swing pedal is to offset the boom with respect to the upperstructure for digging close to a structure.

BLADE CONTROL LEVER

The lever (Item 1)[B] is used to raise and lower the blade.

Position A – Pushed Forward – Lowers the blade.

Position B – Neutral – Blade is stopped and held in position.

Position C – Pulled Backward – Raises the blade.

NOTE: Keep the blade lowered when digging to help stabilize the machine.

AUXILIARY HYDRAULIC PEDAL

WARNING

AVOID BURNS

Hydraulic fluid, tubes, fittings and quick couplers can get hot when running machine and attachments. Be careful when connecting and disconnecting quick couplers.

W-2220-0396

Raise the pedal lock/foot rest (Item 1) [C] to operate the auxiliary operation pedal.

The pedal (Item 2) [C] controls optional equipment when mounted on the arm.

The excavator is equipped with 2-way flow auxiliary lines. Push pedal (Item 2) [C] to activate hydraulic function. Right side of pedal is hydraulic pressure to the female coupler and left is hydraulic pressure to the male coupler.

The female coupler (Item 1) [D] is pressurized, the male coupler (Item 2) [D] is returned when pedal is pushed to the right.

WARNING

Instructions are necessary before operating or servicing machine. Read Operation & Maintenance Manual, and signs (decals) on machine. Follow warnings and instructions in the manuals when making repairs, adjustments or servicing. Check for correct function after adjustments, repairs or service. Failure to follow instructions can cause injury or death.

W-2144-0189

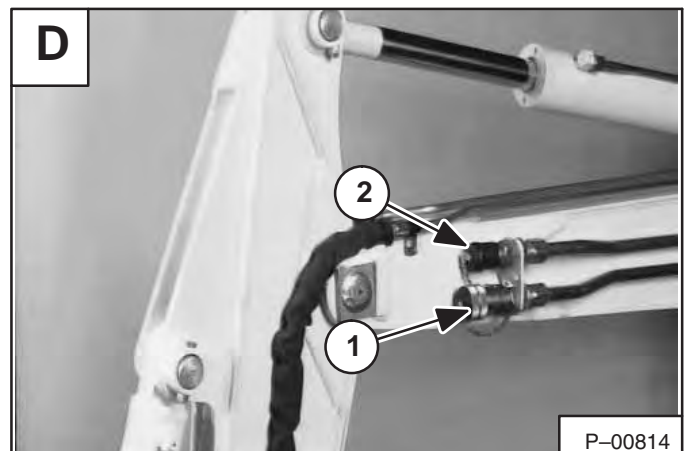
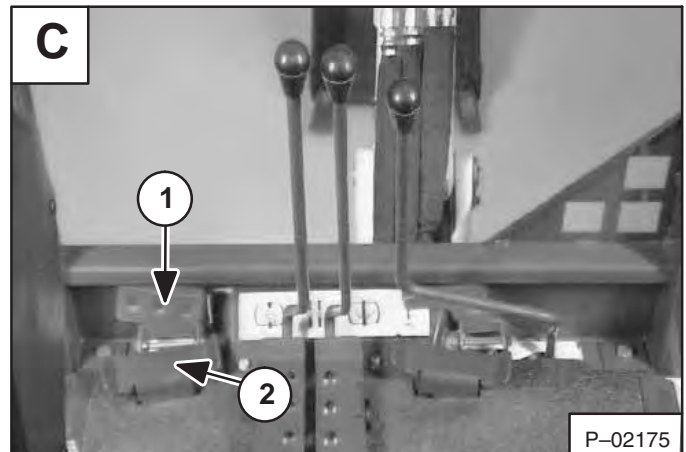
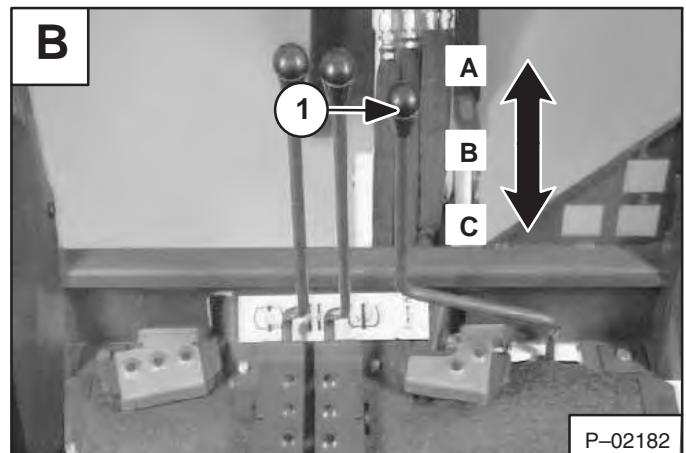
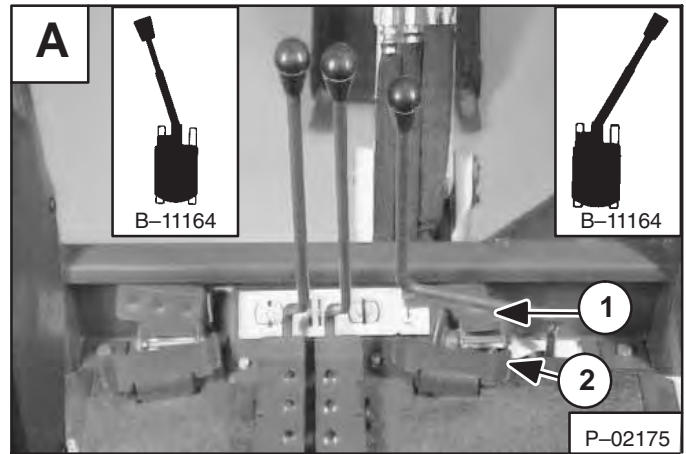

CAB OPTION (Cont'd)

Front Window

The front window (on the optional cab) provides protection from the elements for the operator. The front window is equipped with a wiper and washer [A].

NOTE: A special application frontal guard is available for the cab (Kit number 6666533) and canopy (Kit number 6666863) and must be used when using the hydraulic breaker on the excavator.

Emergency Exit

The left door and right rear window provide exits.

To exit through the right rear side window:

Slide the window to the front of the excavator and exit through the side window [B].

CAB/CANOPY

The excavator has an operator canopy (ROPS) as standard equipment. An enclosed cab (ROPS) is provided as an option. Both the canopy and cab provide operator protection from a rollover.

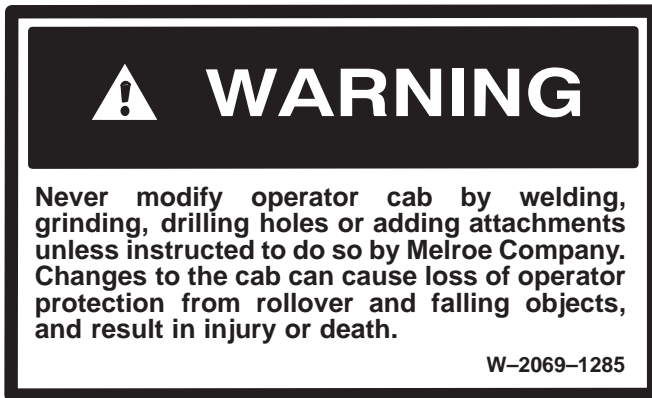

CAB/CANOPY FOPS (Falling Object Protective Structure)

A cab/canopy FOPS (Falling Object Protective Structure) (Item 1) [C] is available as a field installed accessory.

A plastic canopy enclosure kit is available as a field installed accessory (Item 2) [C].

These kits are available through Melroe Parts Sales. See your excavator dealer to order this part.

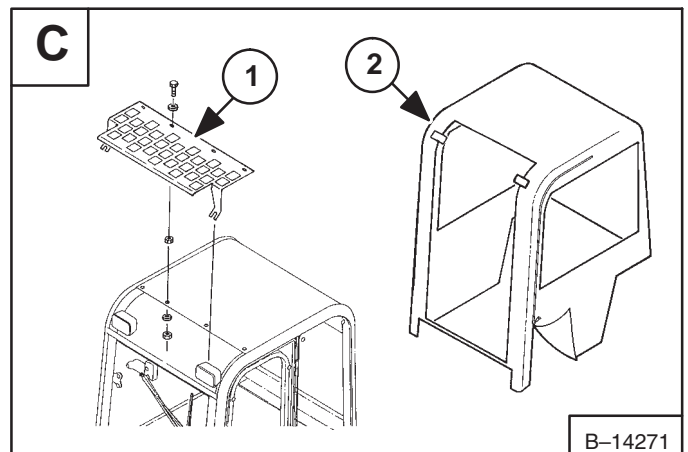

ALTERNATOR BELT ADJUSTMENT

To adjust the belt tension, use the following procedure:

Stop the engine. Open the engine cover.

The belt should deflect about 5/8 inch (16 mm) when pressed between the water pump pulley and crankshaft pulley with approximately 22 lbs. (10 kg) pressure **[A]**.

If the tension is not correct, loosen the alternator mounting bolt.

Loosen the adjustment bolt **[B]**.

Move the alternator until the belt tension is correct.

Tighten the adjustment bolt and mounting bolt.

Replace the belt if it has stretched or there are cracks in the belt. Check the pulley grooves, make sure the belt is not in contact with the bottom of the grooves in the pulleys.

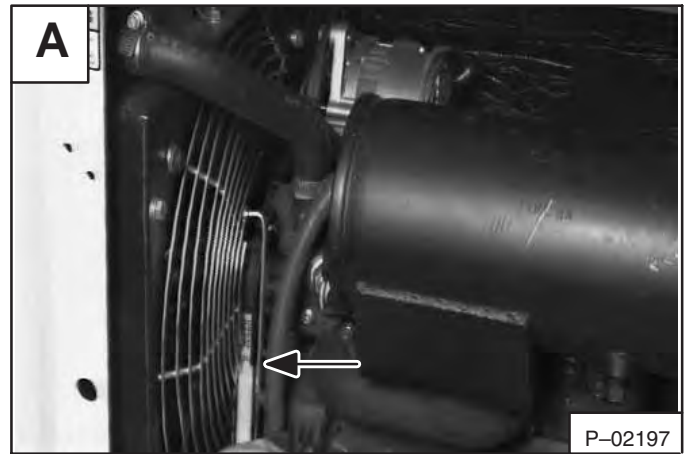

TRACK TENSION

NOTE: The wear of the parts on the undercarriage vary with the working conditions and the different types of soil conditions. It is necessary to inspect track tension to maintain the correct tension. (See *SERVICE SCHEDULE* Page 27 for the correct service interval.)

Adjustment

Raise one side of the machine (approximately 4 inches) using the boom and arm as shown in [A].

Raise the blade fully and install jackstands under the blade and the track frame [A].

Stop the engine.

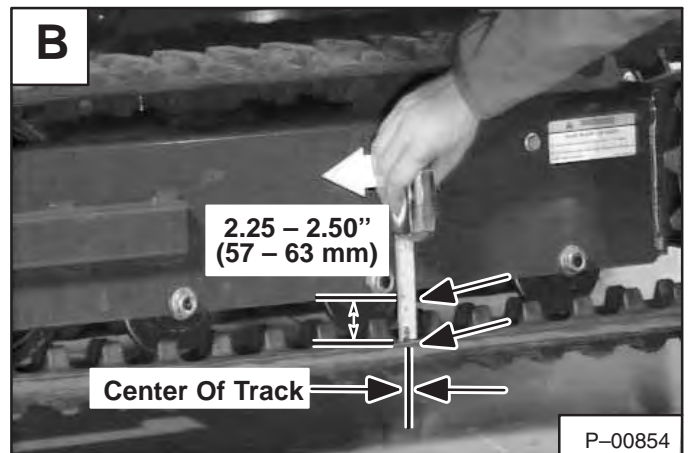

Measure the distance between the frame and the top of the track. If the distance is between 2.25–2.50 inches (57–63 mm), the track tension is correct [B].

If not, loosen one bolt and remove the other bolt from the cover [C].

Add grease to the fitting (Item 1) [D] until the track tension is correct.

If track tension is too tight, decrease the track tension pressure by loosening the bleed screw (Item 2) [D] (maximum of 1 turn) and allow grease to flow out of the bleed screw. When the tension is correct, tighten the bleed screw.

Repeat the procedure for the other side.

If the track tension is still loose after adjusting to the above mentioned limit, it indicates the track is worn. See your dealer for repairs.

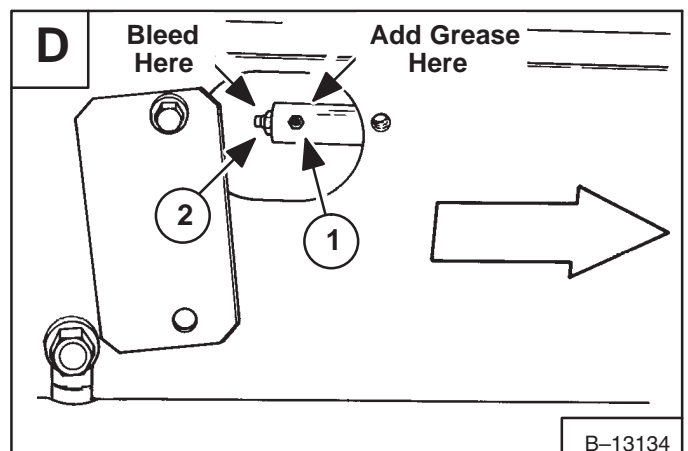
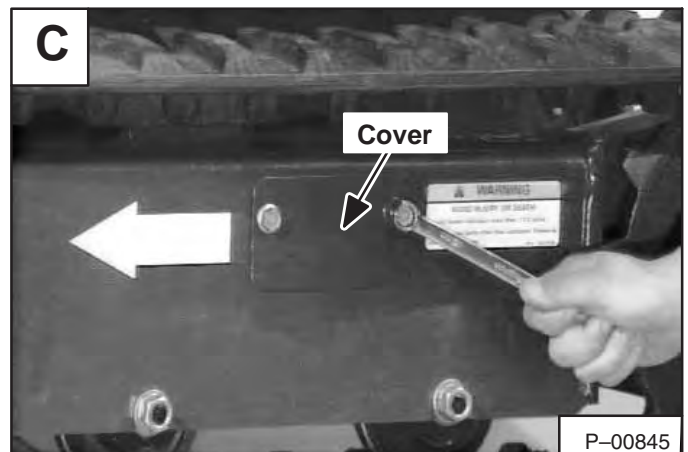

SPECIFICATIONS

BUCKET SPECIFICATIONS	59 .
COOLANT MIXTURE	58 .
ENGINE OIL SPECIFICATIONS	58 .
FUEL, COOLANT AND LUBRICANT CHART	58
HYDRAULIC EXCAVATOR SPECIFICATIONS	54
Brakes	57 .
Capacities	57 .
Controls	56 .
Digging Force	57 .
Drive System	57 .
Engine	56 .
Hydraulic Cylinders	57 .
Hydraulic System	57 .
Lifting Capacity	56 .
Machine Dimensions	55 .
Swing System	57 .
Track	57 .
Travel Speed	56 .
Undercarriage	57 .
Weights	56 .

SPECIFICATIONS

CLICK HERE TO **DOWNLOAD** THE COMPLETE MANUAL

- Thank you very much for reading the preview of the manual.
- You can download the complete manual from: www.heydownloads.com by clicking the link below



- Please note: If there is no response to CLICKING the link, please download this PDF first and then click on it.

CLICK HERE TO **DOWNLOAD** THE COMPLETE MANUAL