



# Bobcat®

---

## Operation & Maintenance Manual T250 Compact Track Loader

---

S/N A5GS11001 - A5GS19999  
S/N A5GT11001 - A5GT19999

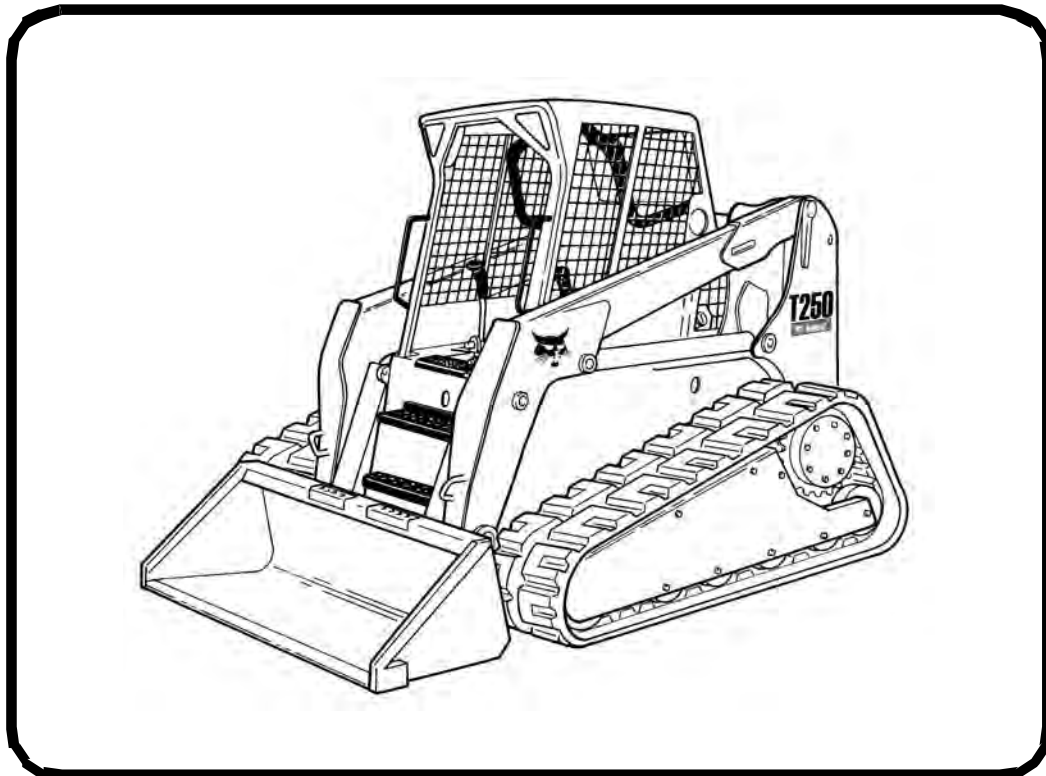

EQUIPPED WITH  
BOBCAT INTERLOCK  
CONTROL SYSTEM (BICS)



CLICK HERE TO **DOWNLOAD** THE COMPLETE MANUAL

- Thank you very much for reading the preview of the manual.
- You can download the complete manual from: [www.heydownloads.com](http://www.heydownloads.com) by clicking the link below



- Please note: If there is no response to CLICKING the link, please download this PDF first and then click on it.

CLICK HERE TO **DOWNLOAD** THE COMPLETE MANUAL

# LOADER IDENTIFICATION

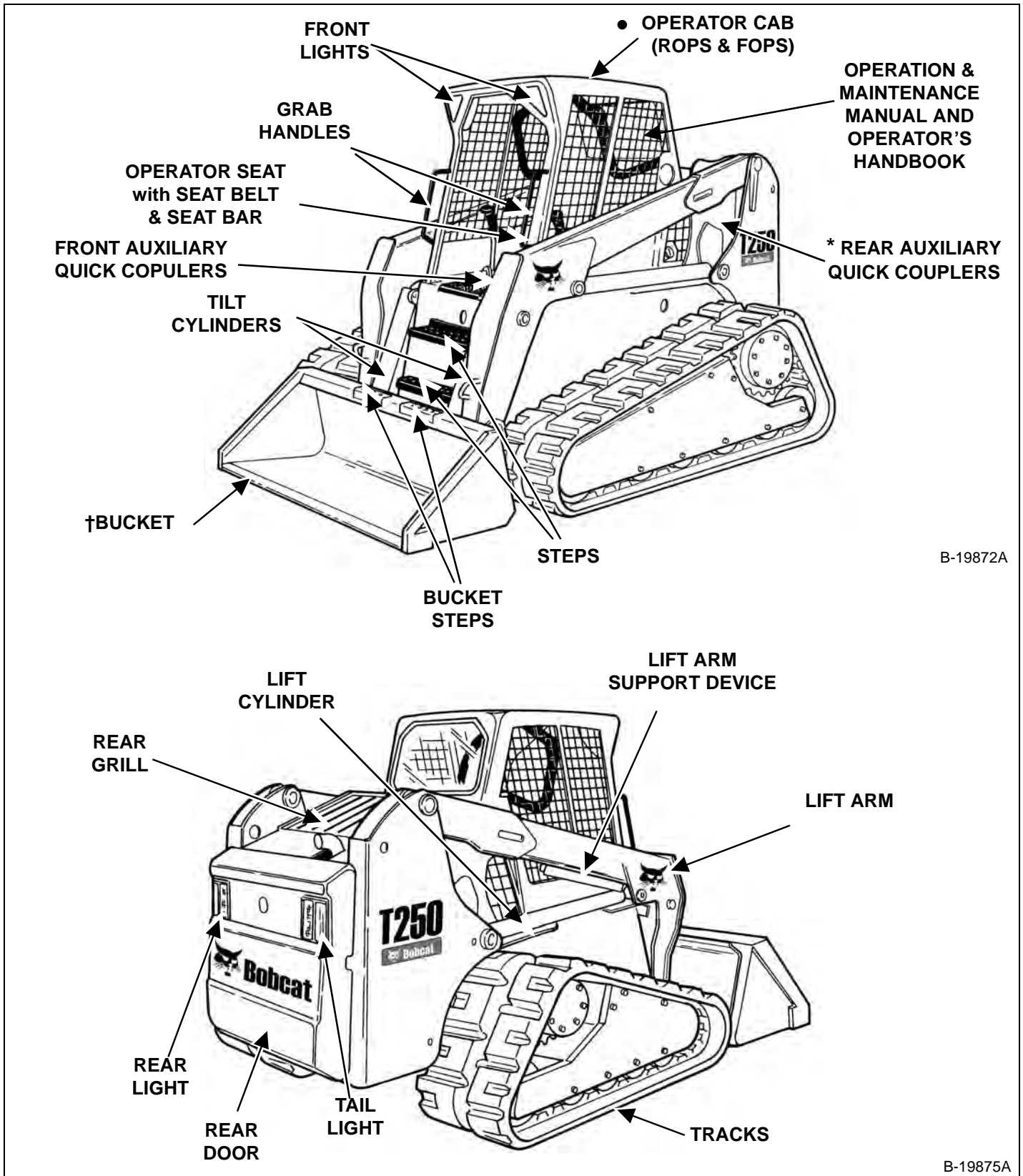

B-19872A

B-19875A

- \* Option or Field Accessory
- † Many buckets and other attachments are available.
- ROPS, FOPS - Roll Over Protective Structure per ISO 3471, and Falling Object Protective Structure ISO 3449, Level I. Level II is available.



**Bobcat®**

## INSTRUMENT PANEL IDENTIFICATION (CONT'D)

### Right Panel (Keyless)

Figure OI-3

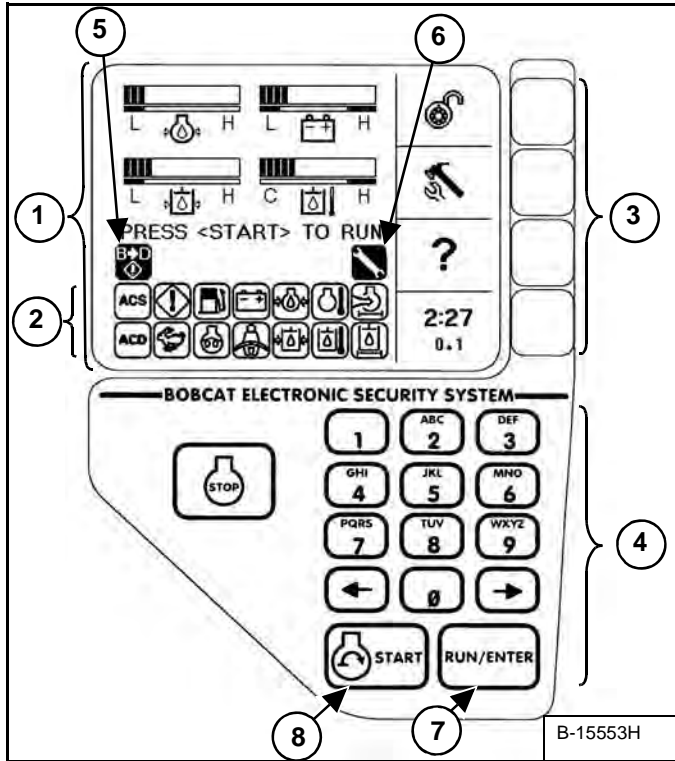

The right instrument panel shown [Figure OI-3] is the Keyless Panel.

1. **Display Screen:** The Display Screen is where all system setup, monitoring, troubleshooting, and error conditions are displayed.
2. **Function Icons:** The lower left area of the Display Screen contains the same icons as the Key Switch Panel. These icons are only visible when the monitoring system has detected the associated condition.
3. **Selection Buttons:** The four Selection Buttons allow you to select items from the Display Screen and scroll through screens.
4. **Keypad:** The numeric keypad has two functions:
  - To enter a number code (password) to allow starting the engine (Keyless Start).
  - To enter a number as directed for further use of the Display Screen.
5. **Bobcat Controller / Display Icon:** Indicates communication error between Bobcat controller and instrument panel. (See DIAGNOSTIC SERVICE CODES on Page SA-4.)
6. **BobCARE PM<sup>SM</sup> Icon:** Indicates planned maintenance is due. (See MAINTENANCE CLOCK on Page SA-14.)

Figure OI-4

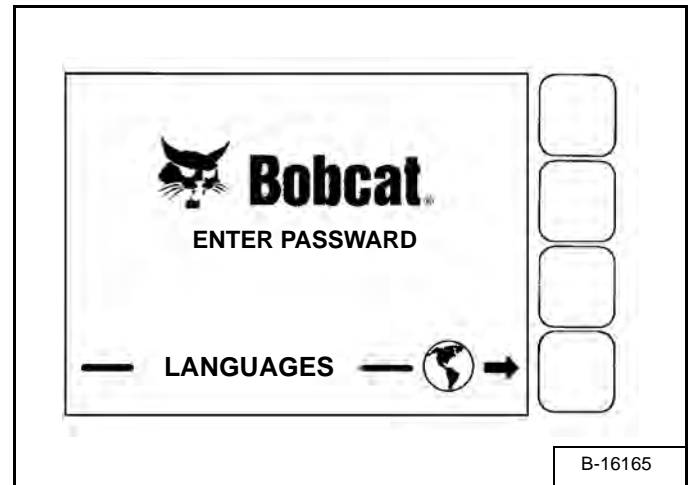

The first screen you will see on your new loader will be as shown in [Figure OI-4].

When this screen is on the display you can enter the password and start the engine or change the Display Panel setup features.

**NOTE:** Your new loader (with Keyless Instrument Panel) will have an Owner Password. Your dealer will provide you with this password. Change the password to one that you will easily remember to prevent unauthorized use of your loader. (See Changing The Owner Password on Page SA-12.) Keep your password in a safe place for future needs.

**Start Engine:** Use the Keypad to enter the numbers (letters) of your password and press the RUN / ENTER key (Item 7) [Figure OI-3].

Press and hold the START button (Item 8) [Figure OI-3] until the engine starts.

**Change Language:** Press the Selection button at the end of the arrow [Figure OI-4] to go to the next screen.

## SPEED MANAGEMENT

Speed Management is available on SJC equipped machines.

### Operation

Speed Management allows the loader to be maneuvered at slow travel speed for installing attachments, loading or unloading, and work applications such as trenching, tilling and landscaping.

Figure OI-26

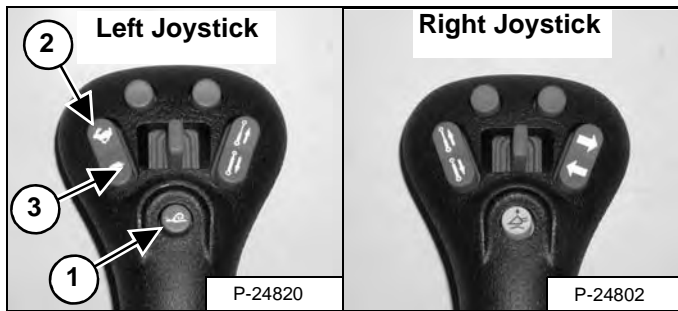

Press the button (Item 1) [Figure OI-26] on the left joystick once to engage Speed Management.

Figure OI-27

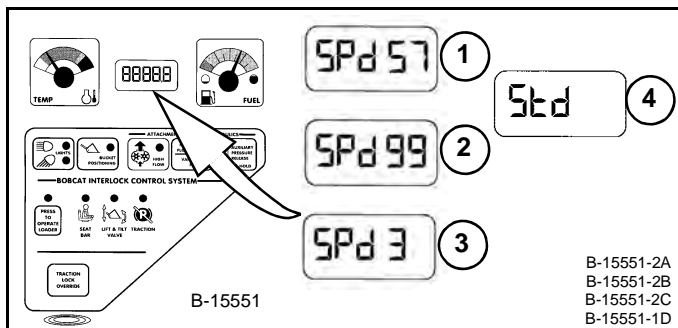

When Speed Management is engaged, the machine will travel at 57% of Standard travel speed and the percentage [SPd 57] will appear in the display (Item 1) [Figure OI-27].

While Speed Management is engaged, press the top of the Speed Control switch (Item 2) [Figure OI-26] to increase the speed up to 99% [SPd 99] or the bottom of the switch (Item 3) [Figure OI-26] to decrease the speed down to 3% [SPd 3]. The percentages will appear in the display (Items 1, 2 and 3) [Figure OI-27].

Press button (Item 1) [Figure OI-26] again to disengage Speed Management and return to Standard Travel Speed ([Std] (Item 4) [Figure OI-27] will appear in display.)

**NOTE:** Early model loaders will show Snl in the display [Figure OI-27] instead of SPd.

The system will retain the speed percentage as long as the key remains ON (Key Switch Panel) or the STOP button has not been pressed (Keyless Panel).

**EXAMPLE:** You can be using the machine at 40% and then disengage Speed Management to reposition the loader, then re-engage Speed Management. The speed percentage will still be at 40%.

**EXAMPLE:** If you turn the key OFF or press the STOP button, the next time you start the engine and engage Speed Management, the speed will be at 57% of Standard Travel Speed. Press button (Item 1) [Figure OI-26] to resume Speed Management Operation.

## HYDRAULIC CONTROLS (CONT'D)

### Secondary Front Auxiliary Hydraulics

This machine may be equipped with Secondary Front Auxiliary Hydraulics.

Figure OI-51

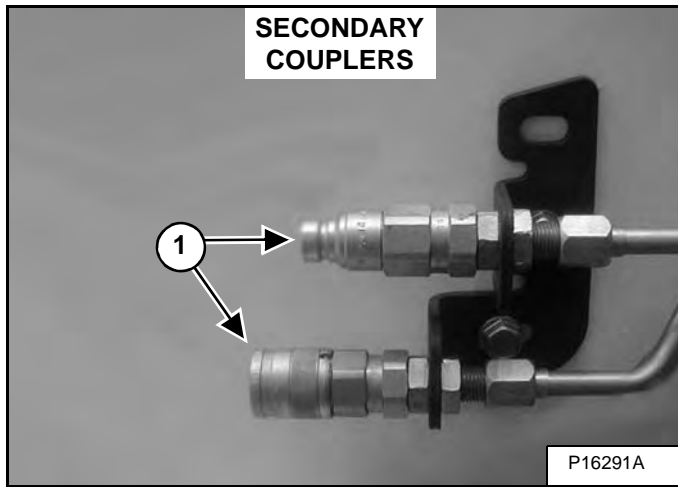

The secondary front auxiliary quick couplers (Item 1) [Figure OI-51] are available as a Field Installed Accessory. These are used when there is a need for additional auxiliary hydraulics. (EXAMPLE: Side shift on the Planer.)

Connect the attachment to the secondary front auxiliary hydraulics (Item 1) [Figure OI-51].

Figure OI-52

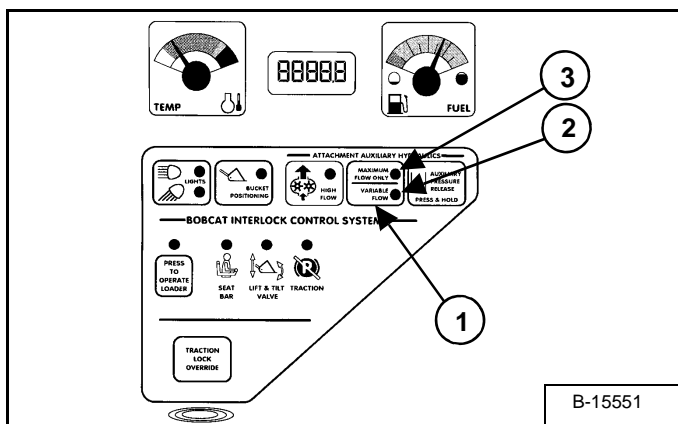

Set the Auxiliary Hydraulics button for *Variable Flow* or *Maximum Flow Only*.

Press the auxiliary hydraulics button (Item 1) [Figure OI-52] once for *VARIABLE FLOW* or twice for *MAXIMUM FLOW ONLY*.

*Standard and ACS (If Equipped)*

Figure OI-53

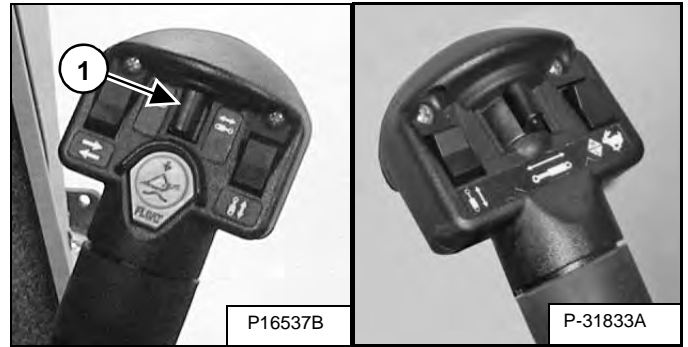

*SJC (If Equipped)*

Figure OI-54

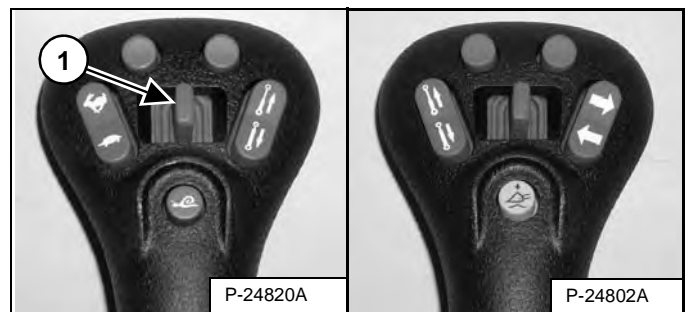

Push switch (Item 1) [Figure OI-53] or [Figure OI-54] to the right or left to change fluid flow direction. (EXAMPLE: Side shift on the Planer.)

**NOTE:** The secondary front auxiliary hydraulics and the rear auxiliary hydraulics operate from the same auxiliary section of the control valve. To operate an attachment with secondary front auxiliary hydraulics, you must disconnect any attachment connected to the rear auxiliary hydraulic quick couplers.

To disengage, press the auxiliary hydraulics button (Item 1) until both lights (Items 2 and 3) [Figure OI-52] are off.

**NOTE:** When the operator is seated and raises the seat bar, the Auxiliary Hydraulic System (Front and Rear) will deactivate.

## STARTING THE ENGINE (CONT'D)

### Keyless (Cont'd)

Figure OI-72

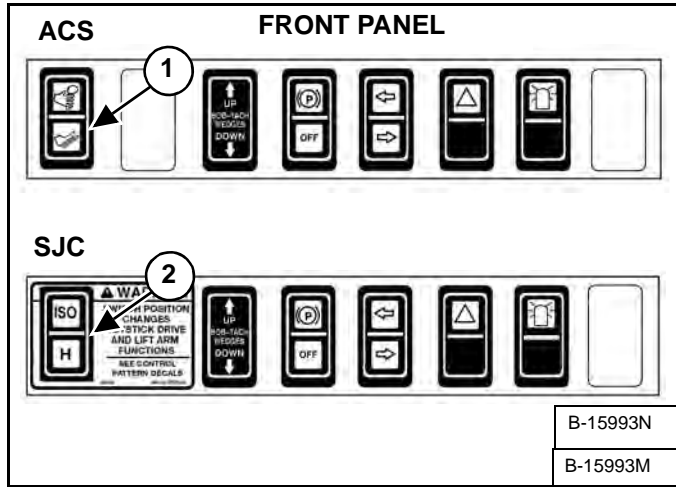

(ACS) Select hand control or foot pedal operation (Item 1) [Figure OI-72].

OR

(SJC) Select 'ISO' or 'H' Control Pattern (Item 2) [Figure OI-72].

Figure OI-73

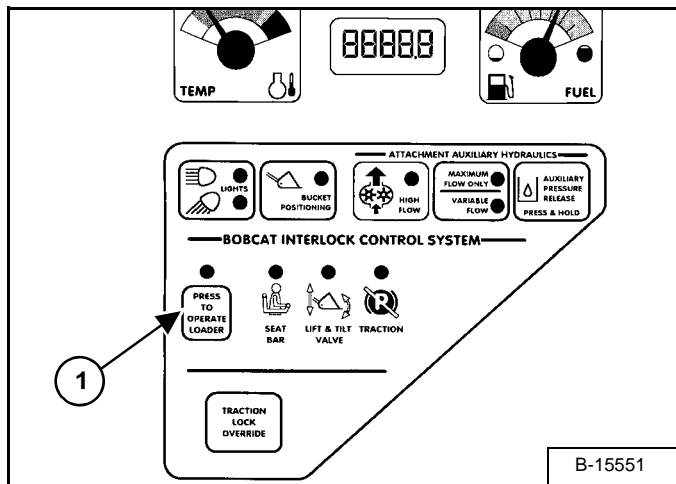

Press the PRESS TO OPERATE LOADER button (Item 1) [Figure OI-73] to activate the BICS system and to perform hydraulic and loader functions. (See Cold Temperature Starting on Page OI-37.)

**NOTE:** (SJC) The pending mode will flash which will indicate PRESS TO OPERATE LOADER is required. The light will flash when key is ON and continue to flash until the PRESS TO OPERATE LOADER button is pressed and thereafter it will light solid. If the mode (ISO/H) is changed while driving, the active mode will be solid and the pending mode will flash. When operation of the machine is returned to neutral, the active mode will then turn off and the pending mode will continue to flash until the PRESS TO OPERATE LOADER button is pressed.

**! WARNING**

### AVOID INJURY OR DEATH

When an engine is running in an enclosed area, fresh air must be added to avoid concentration of exhaust fumes. If the engine is stationary, vent the exhaust outside. Exhaust fumes contain odorless, invisible gases which can kill without warning.

W-2050-0807

### Cold Temperature Starting

**! WARNING**

### AVOID INJURY OR DEATH

Do not use ether with glow plug (preheat) systems. Explosion can result which can cause injury, death, or severe engine damage.

W-2071-0907

If the temperature is below freezing, perform the following to make starting the engine easier:

- Replace the engine oil with the correct type and viscosity for the anticipated starting temperature. (See ENGINE LUBRICATION SYSTEM on Page PM-23.)
- Make sure the battery is fully charged.
- Install an engine heater, available from your Bobcat Loader dealer.
- Move engine speed control lever halfway before starting. Return to idle position after the engine starts.

**NOTE:** The LCD of the Keyless Panel may not be immediately visible when the temperature is below -15°F (-26°C). It may take 30 seconds to several minutes for the Display Panel to warm up. All systems remain monitored even when the display is off.

## ATTACHMENTS (CONT'D)

### Installing And Removing The Attachment (Power Bob-Tach) (Cont'd)

#### Removing

Lower the lift arms and put the attachment flat on the ground. Lower or close any hydraulic equipment, if applicable.

If the attachment has electrical, water or hydraulic connections to the loader:

1. Stop the engine and exit the loader. (See also STOPPING THE ENGINE AND LEAVING THE LOADER.



Before you leave the operator's seat:

- Lower the lift arms, put the attachment flat on the ground.
- Stop the engine.
- Engage the parking brake.
- Raise seat bar.
- (Foot Pedal Controls) Move pedals until both lock.
- (Advanced Control System-ACS) Move the hydraulic controls to the NEUTRAL POSITION to make sure that both lift and tilt functions are deactivated.  
The seat bar system must deactivate the lift and tilt control functions when the seat bar is up. Service the system if hand controls do not deactivate.
- (Selectable Joystick Controls-SJC) Move the joysticks to the NEUTRAL POSITION to make sure that travel and hydraulic functions are deactivated.  
The seat bar system must deactivate these functions when the seat bar is up. Service the system if controls do not deactivate.

W-2463-0603

2. Disconnect attachment electrical harness and water or hydraulic lines, if applicable, from the loader. (See Relieve Hydraulic Pressure (Loader And Attachment) on Page OI-25.)
3. Perform the PRE-STARTING PROCEDURE. (See PRE-STARTING PROCEDURE on Page OI-31.)
4. Start the engine, press the PRESS TO OPERATE LOADER button and release the parking brake.

Figure OI-97

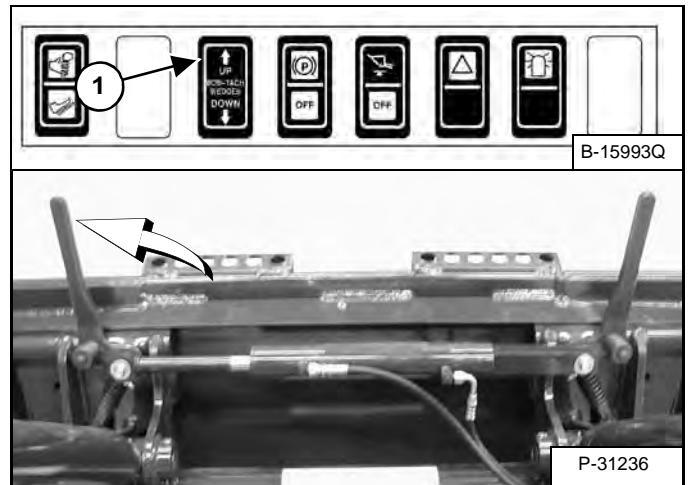

Push and hold the BOB-TACH "WEDGES UP" switch (Front Panel) (Item 1) [Figure OI-97] until the wedges are fully raised.

Figure OI-98

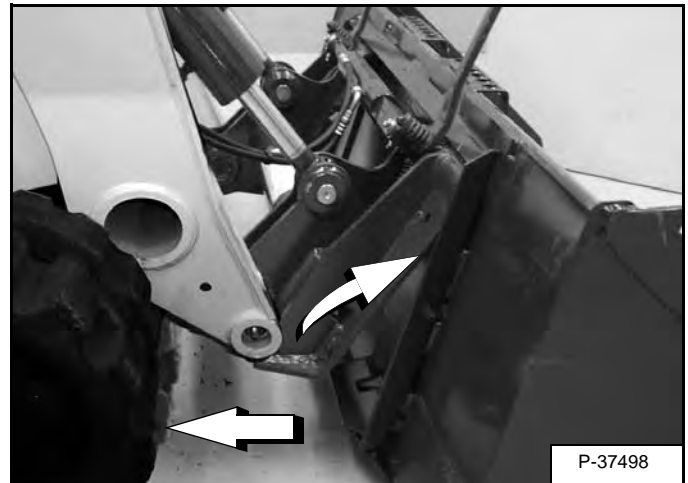

Tilt the Bob-Tach forward and move the loader backward, away from the bucket or attachment [Figure OI-98].

**NOTE:** The Power Bob-Tach system has continuous pressurized hydraulic oil to keep the wedges in the engaged position and prevent attachment disengagement. Because the wedges can slowly lower, the operator may need to reactivate the switch (WEDGES UP) when removing an attachment to be sure both wedges are fully raised.

## OPERATING PROCEDURE (CONT'D)

### Digging And Filling A Hole (ACS - Handles, SJC - 'H' Pattern)

#### Digging

Figure OI-119

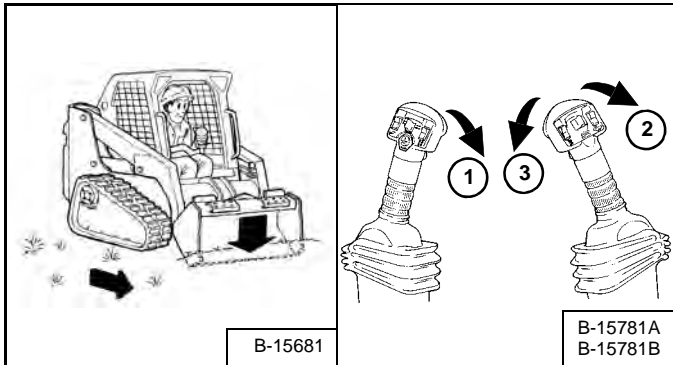

Lower the lift arms all the way (Item 1) [Figure OI-119]. Tilt the bucket forward (Item 2) [Figure OI-119] until the cutting edge of the bucket is on the ground.

Drive forward slowly and continue to tilt the bucket down (Item 2) [Figure OI-119] until it enters the ground.

Tilt the bucket backward a small amount (Item 3) [Figure OI-119] to increase traction and keep an even digging depth. Continue to drive forward until the bucket is full. When the ground is hard, raise and lower the cutting edge (Items 1 & 2) [Figure OI-119] while driving forward.

Figure OI-120

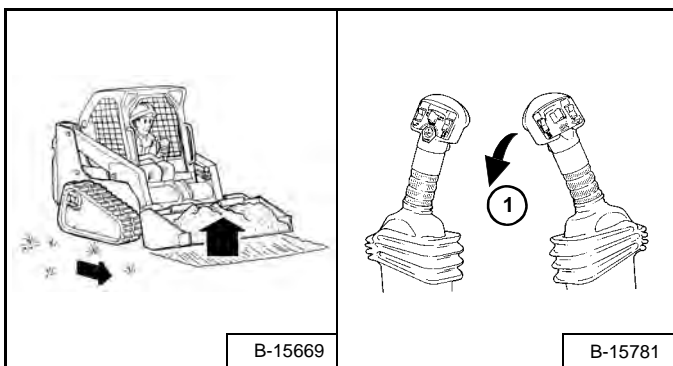

Tilt the bucket backward (Item 1) [Figure OI-120] as far as it will go when the bucket is full.

#### Filling

Figure OI-121

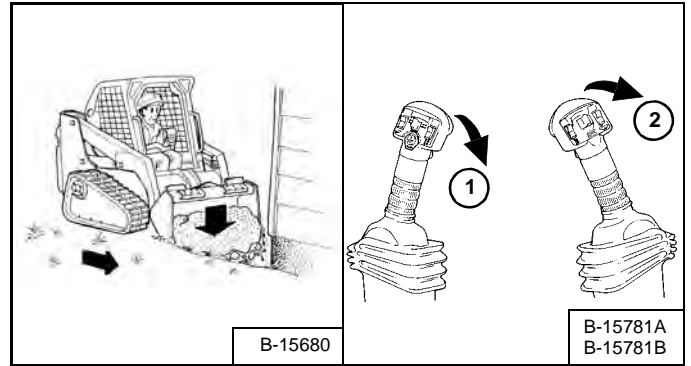

Lower the lift arms (Item 1) [Figure OI-121] and put the cutting edge of the bucket on the ground (Item 2) [Figure OI-121]. Drive forward to the edge of the hole to push the material into the hole.

Tilt the bucket forward (Item 2) [Figure OI-121] as soon as it is past the edge of the hole.

If necessary, raise the lift arms to empty the bucket.

CLICK HERE TO **DOWNLOAD** THE COMPLETE MANUAL

- Thank you very much for reading the preview of the manual.
- You can download the complete manual from: [www.heydownloads.com](http://www.heydownloads.com) by clicking the link below



- Please note: If there is no response to CLICKING the link, please download this PDF first and then click on it.

CLICK HERE TO **DOWNLOAD** THE COMPLETE MANUAL

## PREVENTIVE MAINTENANCE (CONT'D)

OPERATOR CAB .....	PM-12
Cab Door Sensor .....	PM-14
Description .....	PM-12
Lowering .....	PM-13
Raising .....	PM-12
PIVOT PINS .....	PM-46
Inspection And Maintenance .....	PM-46
REAR DOOR .....	PM-15
Adjusting .....	PM-15
Opening And Closing .....	PM-15
REAR GRILL .....	PM-16
Installing .....	PM-16
Removing .....	PM-16
SEAT BAR RESTRAINT SYSTEM .....	PM-7
Description .....	PM-7
Inspecting .....	PM-7
Maintaining .....	PM-7
SEAT BELT .....	PM-8
Inspection and Maintenance .....	PM-8
SERVICE SCHEDULE .....	PM-5
Chart .....	PM-5
TRACK ROLLER AND IDLER LUBRICATION .....	PM-46
Procedure .....	PM-46
TRACK TENSION .....	PM-37
Adjusting .....	PM-37

## BACK-UP ALARM SYSTEM

### Description

This machine may be equipped with a back-up alarm system. The back-up alarm will sound when the operator moves both steering levers or joystick(s) in the reverse position. Slight movement of the steering levers in the reverse position is required with hydrostatic transmissions, before the back-up alarm will sound.

### Inspecting

Figure PM-9



Inspect for damaged or missing back-up alarm decal (Item 1) [Figure PM-9]. Replace if required.

Sit in the seat and fasten the seat belt. Engage the parking brake. Pull the seat bar all the way down. Start the engine. Press the PRESS TO OPERATE LOADER button. Disengage the parking brake.

Move both steering levers or joystick(s) in the reverse position. The back-up alarm must sound when all wheels or both tracks are moving in reverse.

The back-up alarm is located on the inside of the rear door.

Figure PM-10

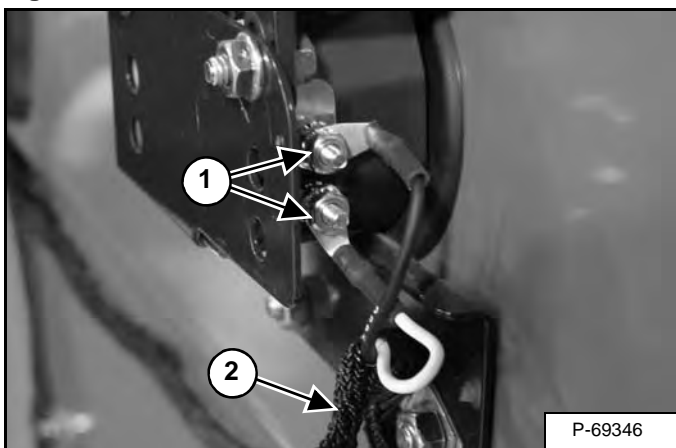

Inspect the back-up alarm electrical connections (Item 1) [Figure PM-10], wire harness (Item 2) [Figure PM-10] and back-up alarm switches (if equipped) (Item 2) [Figure PM-11] for tightness and damage. Repair or replace any damaged components.

If the back-up alarm switches require adjustment, (See Adjusting Switch Position on Page PM-11.)

### Adjusting Switch Position

**NOTE: Joystick equipped machines do not have back-up alarm switches and can not be adjusted. See your Bobcat dealer for service if your back-up alarm does not sound.**

### Standard Controls and ACS (If Equipped)

Stop the engine and raise the operator cab. (See Raising on Page PM-12.)

Figure PM-11

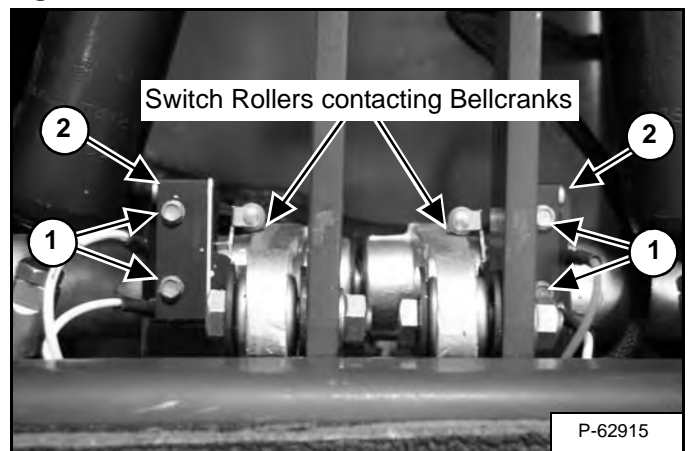

Place the steering levers in the neutral position.

Loosen the screws (Item 1) [Figure PM-11] securing the back-up alarm switches.

Position the back-up alarm switch rollers so that they just make contact with bellcranks without compressing the switch springs [Figure PM-11]. Torque the screws (Item 1) [Figure PM-11] securing the switches to the bracket to 14-19 in.-lb. (1,6-2,1 N•m).

Lower the operator cab. (See Lowering on Page PM-13.) Inspect back-up alarm system for proper function. (See Inspecting on Page PM-11.)

## FUEL SYSTEM (CONT'D)

### Filling The Fuel Tank

# ! WARNING

## AVOID INJURY OR DEATH

Stop and cool the engine before adding fuel. **NO SMOKING!** Failure to obey warnings can cause an explosion or fire.

W-2063-0807

Install and tighten the fuel cap (Item 1) [Figure PM-32].

# ! WARNING

## AVOID INJURY OR DEATH

Always clean up spilled fuel or oil. Keep heat, flames, sparks or lighted tobacco away from fuel and oil. Failure to use care around combustibles can cause explosion or fire which can result in injury or death.

W-2103-0807

Figure PM-32

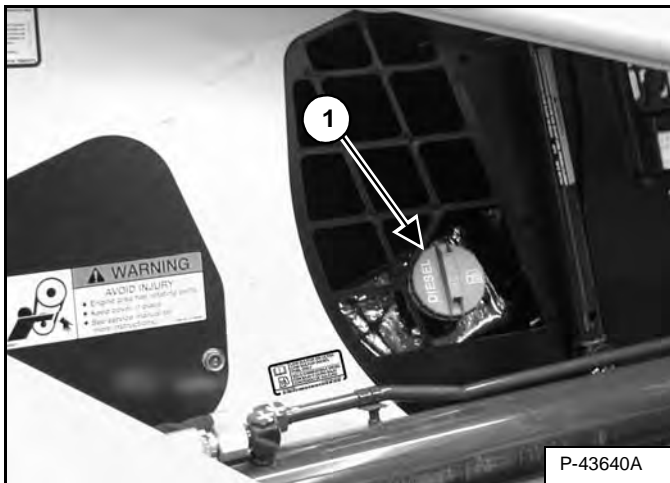

Remove the fill cap (Item 1) [Figure PM-32].

Figure PM-33

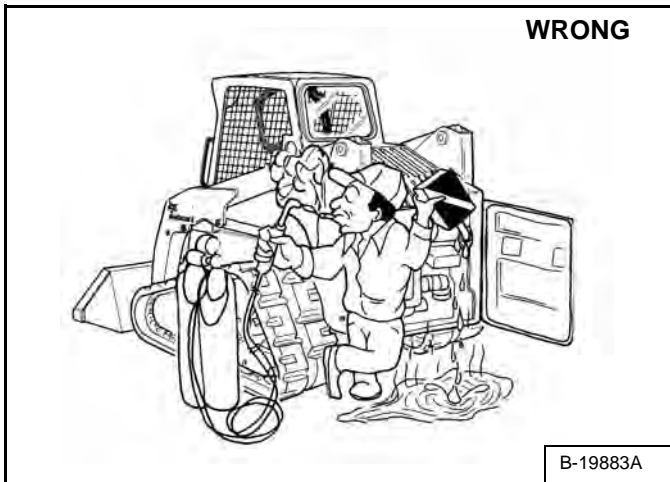

Use a clean, approved safety container to add fuel of the correct specification. Add fuel only in an area that has free movement of air and no open flames or sparks **NO SMOKING** [Figure PM-33].

## HYDRAULIC / HYDROSTATIC SYSTEM (CONT'D)

### Removing And Replacing Hydraulic Fluid

For the correct service interval (See SERVICE SCHEDULE on Page PM-5.)

Replace the fluid if it becomes contaminated or after major repair.

Always replace the hydraulic / hydrostatic filter, the case drain filters and the hydraulic charge filter whenever the hydraulic fluid is replaced. (See Removing And Replacing Hydraulic / Hydrostatic Filter on Page PM-32.)

Remove the fill cap and raise the operator cab. (See Raising on Page PM-12.)

#### Hydraulic Fill Screen

Figure PM-54

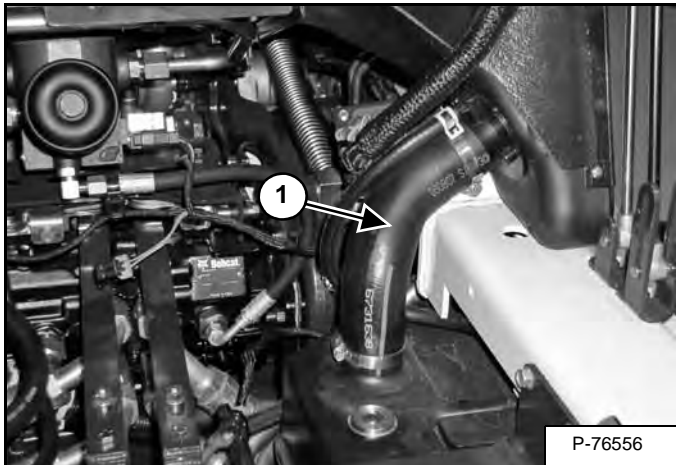

Remove the two hose clamps and remove the hose (Item 1) [Figure PM-54].

Figure PM-55

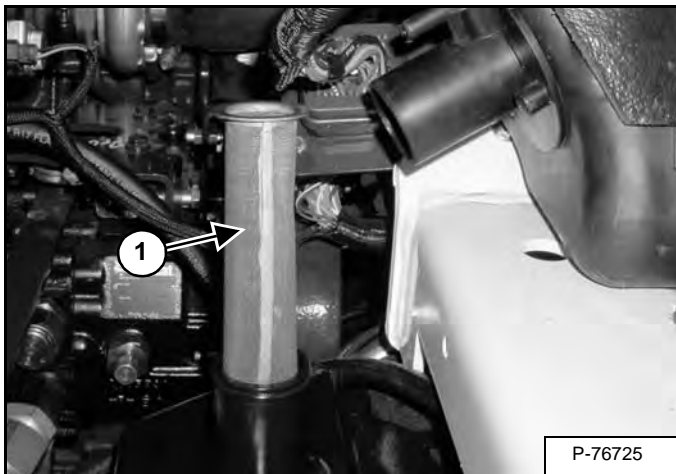

Remove and clean the hydraulic fill screen (Item 1) [Figure PM-55]. Use low air pressure to dry the screen.

Install screen, hose and hose clamps.

Figure PM-56

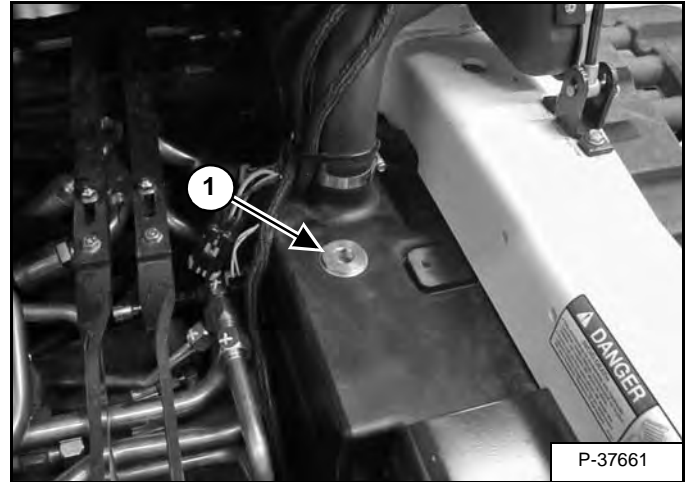

Remove the plug from the top of the reservoir (Item 1) [Figure PM-56]. Use a suction device to remove the fluid.

Recycle or dispose of used fluid in an environmentally safe manner.

**! WARNING**

#### AVOID INJURY OR DEATH

Always clean up spilled fuel or oil. Keep heat, flames, sparks or lighted tobacco away from fuel and oil. Failure to use care around combustibles can cause explosion or fire which can result in injury or death.

W-2103-0807

Install the plug (Item 1) [Figure PM-56].

Lower the operator cab. (See Lowering on Page PM-13.)

Add the correct fluid to the reservoir until the fluid level is at the center of the sight gauge. (See Checking And Adding Fluid on Page PM-30.)

## AIR CONDITIONING BELT

### Belt Adjustment

Stop the engine.

Figure PM-73

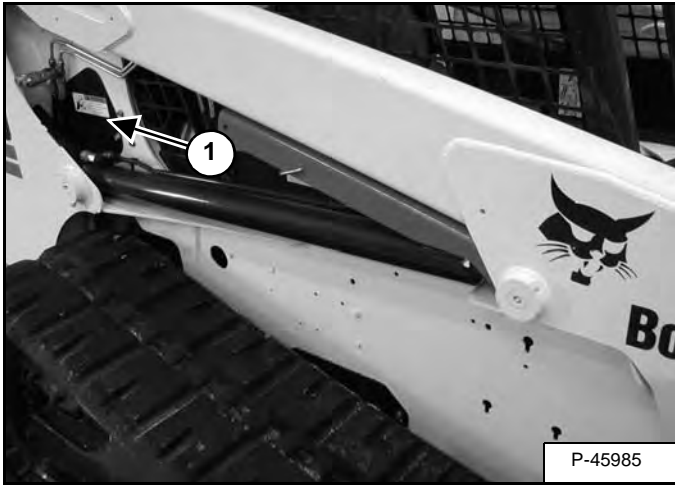

Remove the right side access cover (Item 1) [Figure PM-73].

Figure PM-74

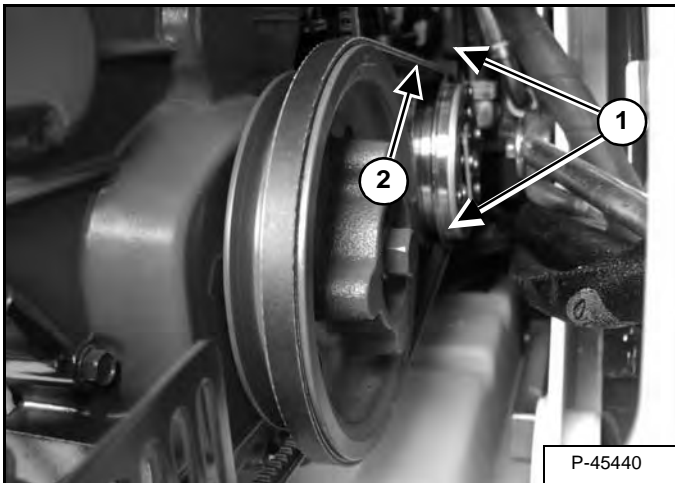

Loosen the mounting and adjustment bolts (Item 1) [Figure PM-74].

Move the air conditioner pump toward the front of machine to tighten the belt. The tension is correct when there is 5/16 in. (8,0 mm) movement at the middle of the belt span (Item 2) [Figure PM-74] with 15 lb. (66 N) of force.

Install the right side access cover.

### Belt Replacement

Remove the right side access cover (Item 1) [Figure PM-73].

Loosen the mounting and adjustment bolts (Item 1) [Figure PM-74].

Move the air conditioner pump toward the rear of machine to loosen the belt.

Remove the belt from the pulleys and inspect the pulleys for wear. Replace as needed.

Install new air conditioning belt.

Adjust the belt.

Install the right side access cover.

## SYSTEM SETUP & ANALYSIS

BOBCAT INTERLOCK CONTROL SYSTEM (BICS) .....	SA-3
Troubleshooting Chart .....	SA-3
CONTROL PANEL SETUP .....	SA-10
Attachment Control Information (Keyless) .....	SA-11
Right Panel Setup (Keyless) .....	SA-10
DIAGNOSTIC SERVICE CODES .....	SA-4
Service Codes List .....	SA-5
Viewing Service Codes (Key Switch) .....	SA-4
Viewing Service Codes (Keyless) .....	SA-4
MAINTENANCE CLOCK .....	SA-14
Description .....	SA-14
Reset .....	SA-14
Setup .....	SA-14
PASSWORD SETUP .....	SA-12
Changing The Owner Password .....	SA-12
Changing The User Passwords .....	SA-13
Password Description .....	SA-12
Password Lockout Feature .....	SA-13

**SYSTEM SETUP  
& ANALYSIS  
(SA)**

## CONTROL PANEL SETUP (CONT'D)

### Right Panel Setup (Keyless) (Cont'd)

More Examples

#### Clocks

Press . . .  
**TOOL/SETUP**  
**LOADER FEATURES**  
**DISPLAY OPTIONS**  
**CLOCKS**

#### **SET CLOCK**

Use the keypad to set time.  
 Press **RUN/ENTER** to set clock.  
 Press **EXIT** to return to previous level menu.

#### **RESET JOB CLOCK** (Password required)

(Job Clock keeps a running total for job hours)  
 Press **CLEAR** to reset Job Clock to zero.  
 Press **LOCK/UNLOCK** to unlock.  
 Enter Password and press **RUN/ENTER**.

#### Languages

Press . . .  
**TOOL/SETUP**  
**LOADER FEATURES**  
**DISPLAY OPTIONS**

#### **LANGUAGES**

Select the language, press **RUN/ENTER**.  
 Press **EXIT** to return to previous level menu.

Vitals (Monitor the engine, hydraulic/hydrostatic, electrical functions when engine is running.)

Press . . .  
**TOOL/SETUP**  
**LOADER FEATURES.**

#### **VITALS**

Press **SELECTION ARROW** to select METRIC or ENGLISH (M/E) readouts

You can monitor real-time readouts of:

- Engine Oil Pressure**
- Engine Coolant Temperature**
- Hydraulic Charge Pressure**
- Hydraulic Oil Temperature**
- System Voltage**
- Engine Speed**

The Keyless Right Panel is easy to use. Continue to set your own preferences for running / monitoring your Bobcat Loader.

## Attachment Control Information (Keyless)

The Keyless Right Panel allows the user to view information concerning the operation of Bobcat attachments.

Figure SA-5

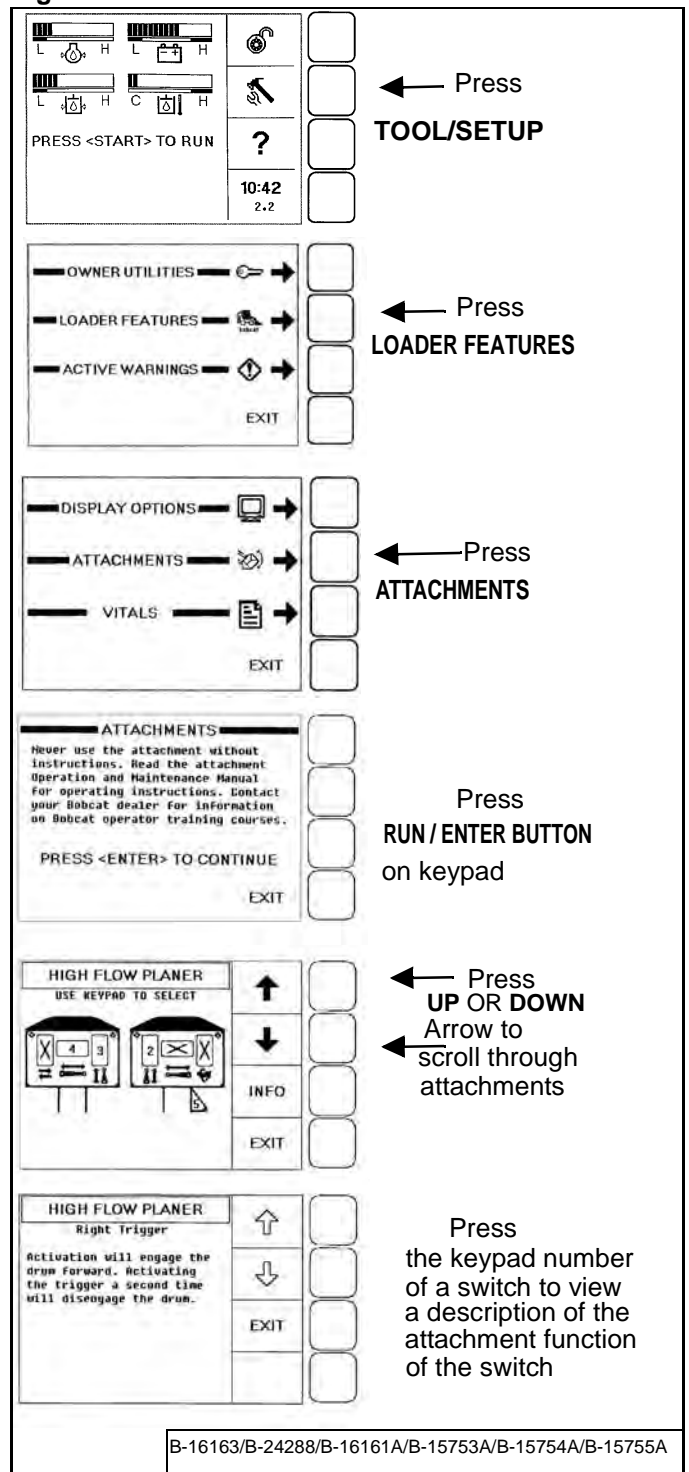

Attachments are listed alphabetically. Press the exit button to return one screen or press the "0" (zero) key to return to the home screen immediately [Figure SA-5].

**WARNING (6718396)**

**WARNING**

**AVOID INJURY OR DEATH**

- Never carry riders.
- Never use loader as a man lift or work platform.

62702 SW 6718396B enUS

**ADVERTENCIA**

**PELIGRO DE LESIONES O DE MUERTE**

- No transporte nunca a nadie.
- No utilice la cargadora como plataforma de trabajo o de elevación para operarios.

62702 SW 6718396B ar

**AVERTISSEMENT**

**RISQUE DE BLESSURES GRAVES, VOIRE MORTELLES**

- Ne transportez jamais de passagers.
- N'utilisez jamais la chargeuse comme élévateur de personnel ni comme plateforme de travail.

62702 SW 6718396B fr

**DANGER (6809511)**

<p><b>DANGER</b></p> <p><b>AVOID DEATH</b></p> <ul style="list-style-type: none"> <li>• Disconnecting hydraulic lines can cause the lift arms or attachment to drop.</li> <li>• Always use an approved lift arm support when lift arms are in a raised position.</li> </ul>		<p>70485 SW 6809511C enUS <b>DANGER</b> NE TOQUEZ PAS LES LIGNES HYDRAULIQUES NI LES BRAS DE LEVAGE EN POSITIONNANT L'ACCESSOIRE. NE TOQUEZ PAS LES LIGNES HYDRAULIQUES NI LES BRAS DE LEVAGE EN POSITIONNANT L'ACCESSOIRE.</p>	<p>70485 SW 6809511C enUS <b>DANGER</b> NE TOQUEZ PAS LES LIGNES HYDRAULIQUES NI LES BRAS DE LEVAGE EN POSITIONNANT L'ACCESSOIRE. NE TOQUEZ PAS LES LIGNES HYDRAULIQUES NI LES BRAS DE LEVAGE EN POSITIONNANT L'ACCESSOIRE.</p>	<p><b>DANGER</b></p> <p><b>AVOID DEATH</b></p> <ul style="list-style-type: none"> <li>• Disconnecting hydraulic lines can cause the lift arms or attachment to drop.</li> <li>• Always use an approved lift arm support when lift arms are in a raised position.</li> </ul>	
---	--	---	---	---	--

<p><b>PELIGRO</b></p> <p><b>EVITE LESIONES FATALES</b></p> <ul style="list-style-type: none"> <li>• Desconectar las líneas hidráulicas puede provocar que los brazos de elevación o el implemento se caigan.</li> <li>• Utilice siempre un soporte aprobado cuando los brazos de elevación están levantados.</li> </ul>		<p>70485 SW 6809511C ar <b>PELIGRO</b> NE TOQUEZ PAS LAS LINEAS HIDRAULICAS NI LOS BRAZOS DE ELEVACION O EL IMPLEMENTO CUANDO SE CALGAN. NE TOQUEZ PAS LAS LINEAS HIDRAULICAS NI LOS BRAZOS DE ELEVACION O EL IMPLEMENTO CUANDO SE CALGAN.</p>	<p>70485 SW 6809511C ar <b>PELIGRO</b> NE TOQUEZ PAS LAS LINEAS HIDRAULICAS NI LOS BRAZOS DE ELEVACION O EL IMPLEMENTO CUANDO SE CALGAN. NE TOQUEZ PAS LAS LINEAS HIDRAULICAS NI LOS BRAZOS DE ELEVACION O EL IMPLEMENTO CUANDO SE CALGAN.</p>	<p><b>PELIGRO</b></p> <p><b>EVITE LESIONES FATALES</b></p> <ul style="list-style-type: none"> <li>• Desconectar las líneas hidráulicas puede provocar que los brazos de elevación o el implemento se caigan.</li> <li>• Utilice siempre un soporte aprobado cuando los brazos de elevación están levantados.</li> </ul>	
---	--	--	--	---	--

<p><b>DANGER</b></p> <p><b>DANGER DE MORT</b></p> <ul style="list-style-type: none"> <li>• Le débranchement des conduites hydrauliques peut provoquer la chute des bras de levage ou de l'accessoire.</li> <li>• Utilisez toujours un arrêt de bras de levage approuvé quand les bras de levage sont relevés.</li> </ul>		<p>70485 SW 6809511C fr <b>DANGER</b> NE TOQUEZ PAS LES LIGNES HYDRAULIQUES NI LES BRAS DE LEVAGE EN POSITIONNANT L'ACCESSOIRE. NE TOQUEZ PAS LES LIGNES HYDRAULIQUES NI LES BRAS DE LEVAGE EN POSITIONNANT L'ACCESSOIRE.</p>	<p>70485 SW 6809511C fr <b>DANGER</b> NE TOQUEZ PAS LES LIGNES HYDRAULIQUES NI LES BRAS DE LEVAGE EN POSITIONNANT L'ACCESSOIRE. NE TOQUEZ PAS LES LIGNES HYDRAULIQUES NI LES BRAS DE LEVAGE EN POSITIONNANT L'ACCESSOIRE.</p>	<p><b>DANGER</b></p> <p><b>DANGER DE MORT</b></p> <ul style="list-style-type: none"> <li>• Le débranchement des conduites hydrauliques peut provoquer la chute des bras de levage ou de l'accessoire.</li> <li>• Utilisez toujours un arrêt de bras de levage approuvé quand les bras de levage sont relevés.</li> </ul>	
--	--	---	---	--	--

## SPECIFICATIONS

(T250) LOADER SPECIFICATIONS .....	SPEC-3
Capacities .....	SPEC-6
Controls .....	SPEC-4
Drive System .....	SPEC-6
Electrical .....	SPEC-6
Engine .....	SPEC-4
Ground Pressure .....	SPEC-6
Hydraulic System .....	SPEC-5
Machine Dimensions .....	SPEC-3
Performance .....	SPEC-4
Tracks .....	SPEC-6

**SPECIFICATIONS**

CLICK HERE TO **DOWNLOAD** THE COMPLETE MANUAL

- Thank you very much for reading the preview of the manual.
- You can download the complete manual from: [www.heydownloads.com](http://www.heydownloads.com) by clicking the link below



- Please note: If there is no response to CLICKING the link, please download this PDF first and then click on it.

CLICK HERE TO **DOWNLOAD** THE COMPLETE MANUAL