

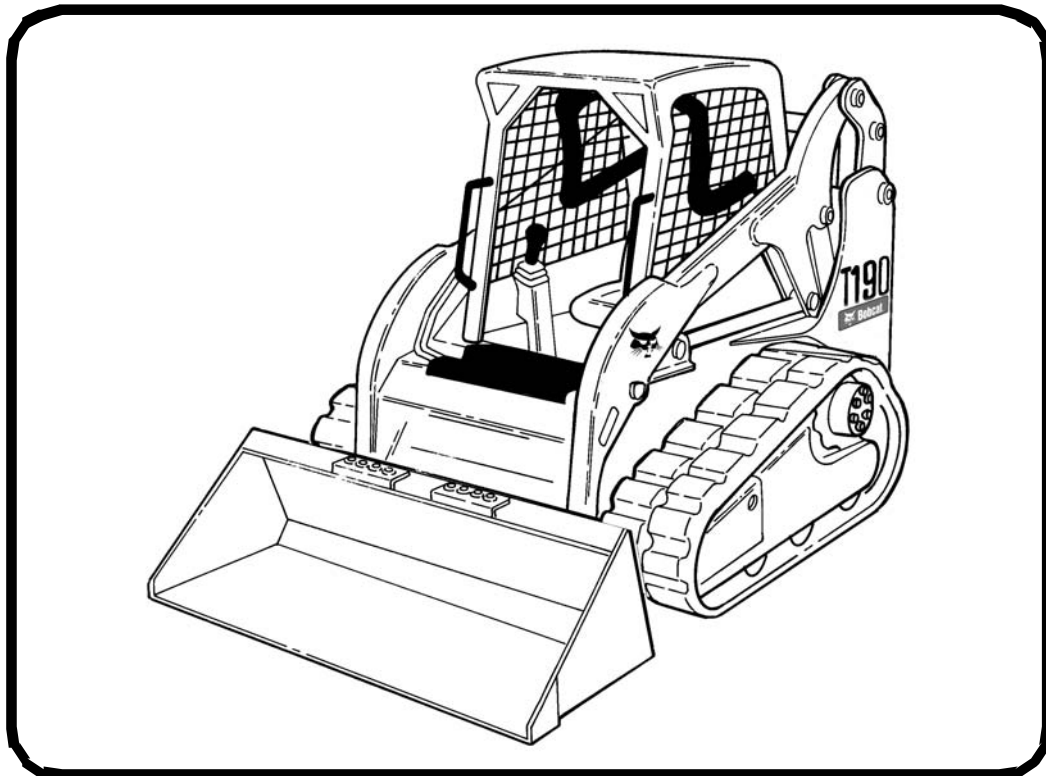

Bobcat®

Operation & Maintenance Manual T190 Compact Track Loader

S/N A3LN36500 & Above



EQUIPPED WITH
BOBCAT INTERLOCK
CONTROL SYSTEM (BICS™)



CLICK HERE TO **DOWNLOAD** THE COMPLETE MANUAL

- Thank you very much for reading the preview of the manual.
- You can download the complete manual from: www.heydownloads.com by clicking the link below



- Please note: If there is no response to CLICKING the link, please download this PDF first and then click on it.

CLICK HERE TO **DOWNLOAD** THE COMPLETE MANUAL

LOADER IDENTIFICATION

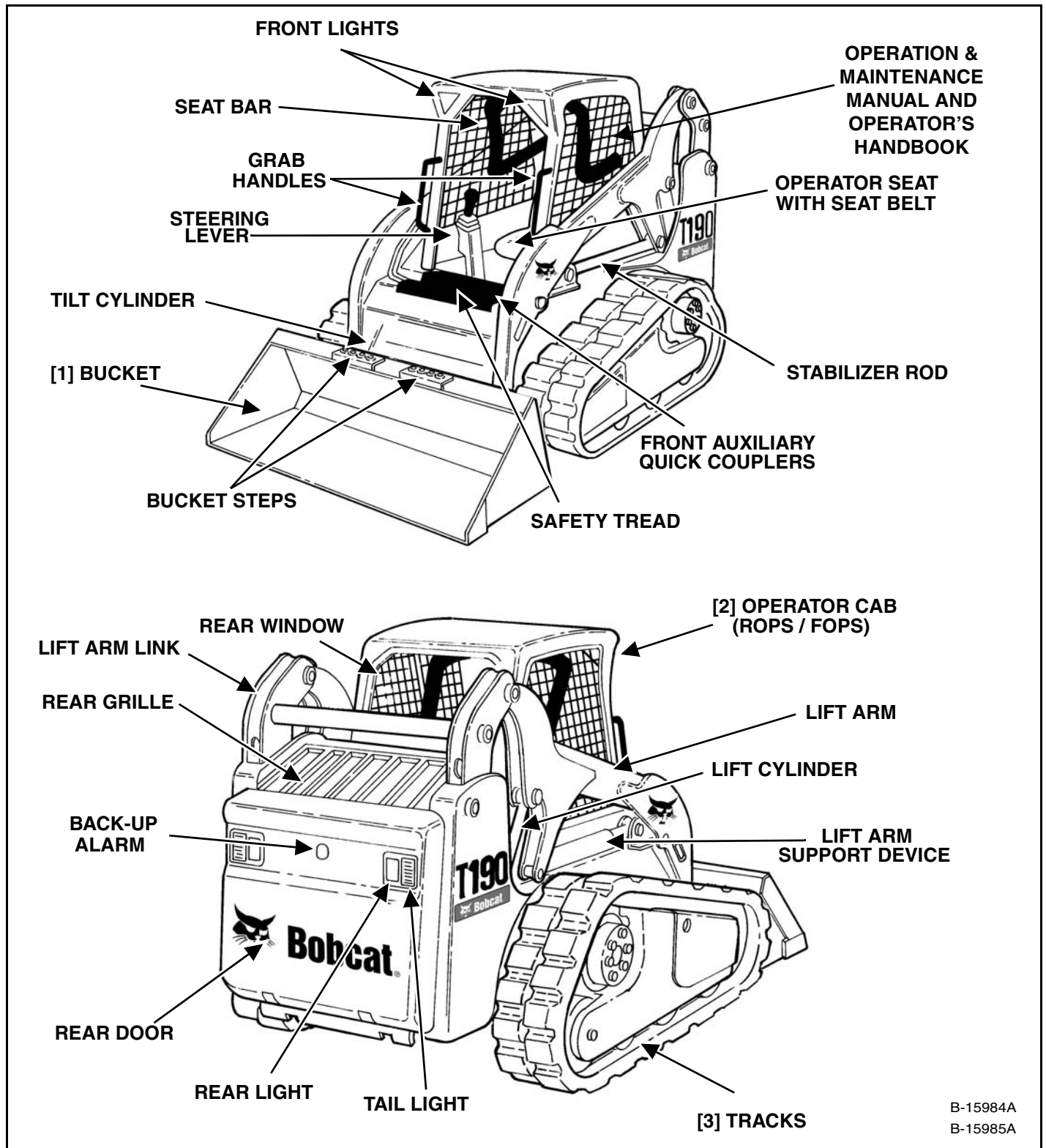

B-15984A
B-15985A

- [1] BUCKETS - Several different buckets and other attachments are available for the Bobcat loader.
- [2] ROPS - Roll-Over Protective Structure per ISO 3471 and FOPS - Falling- Object Protective Structure per ISO 3449, Level I. Level II is available.
- [3] TRACKS - Optional tracks are available.



Bobcat®

INSTRUMENT PANEL IDENTIFICATION (CONT'D)

Left Panel (Cont'd)

REF. NO.	DESCRIPTION	FUNCTION / OPERATION
1	ENGINE TEMPERATURE GAUGE	Shows the engine coolant temperature.
2	LEFT TURN SIGNAL (Option)	Indicates left turn signals are ON.
3	GENERAL WARNING	Malfunction with one or more machine functions. (See Service Codes*)
4	TWO-SPEED	Not used.
5	ENGINE MALFUNCTION	Engine malfunction or failure. (See Service Codes*)
6	ENGINE COOLANT TEMPERATURE	Engine coolant temperature high or sensor error.
7	DISPLAY SCREEN	Displays information. (See Display Screen in this manual.)
8	SEAT BELT	Instructs operator to fasten seat belt. Remains lit for 45 seconds.
9	SEAT BAR	The light comes on when the seat bar is UP.
10	LIFT & TILT VALVE	The light comes on when the lift and tilt functions cannot be operated.
11	PARKING BRAKE	The light comes on when the loader cannot be driven.
12	RIGHT TURN SIGNAL (Option)	Indicates right turn signals are ON.
13	SHOULDER BELT	Not used.
14	HYDRAULIC SYSTEM MALFUNCTION	Hydraulic system malfunction or failure. (See Service Codes*)
15	FUEL	Fuel level low or sensor error.
16	FUEL GAUGE	Shows the amount of fuel in the tank.
17	LIGHTS	Press once for FRONT work lights and REAR taillights. (Left green LED will light.) Press a second time to add REAR work lights. (Left and right green LEDs will light.) Press a third time to turn all lights off. (Left and right green LEDs will be off.) Press and hold five seconds to display software version in display screen.
18	HIGH-FLOW (Option)	Press once to engage the HIGH-FLOW auxiliary hydraulics. (Left green LED will light.) Press a second time to disengage.
19	AUXILIARY HYDRAULICS	Press once to engage the auxiliary hydraulics. (Left green LED will light.) Press a second time to disengage.
20	INFORMATION	Cycles through (after each button press): <ul style="list-style-type: none"> • Hourmeter (On start up) • Engine rpm • Battery voltage • Maintenance clock (Press and hold for seven seconds when displayed to reset the maintenance clock.) • Service codes*
21	TRACTION LOCK OVERRIDE	Functions only when the seat bar is raised and the engine is running. Press once to unlock the brakes. Allows you to use the steering levers or joystick(s) to move the loader forward or backward when using the backhoe attachment. (See TRACTION LOCK OVERRIDE in this manual.) Press a second time to lock the brakes.
22	PRESS TO OPERATE LOADER	Press to activate the BICS™ when the seat bar is down and operator is seated in operating position. Button will light. Press and hold three seconds to engage Drive Response and Steering Drift Compensation. (See DRIVE RESPONSE and STEERING DRIFT COMPENSATION in this manual.)
23	ALARM	The alarm beeps when Error, Warning or Shutdown conditions exist.

* See SYSTEM SETUP & ANALYSIS for Service Code description. (See DIAGNOSTIC SERVICE CODES on Page 157.)

LIFT ARM BYPASS CONTROL

Operation

Figure 24

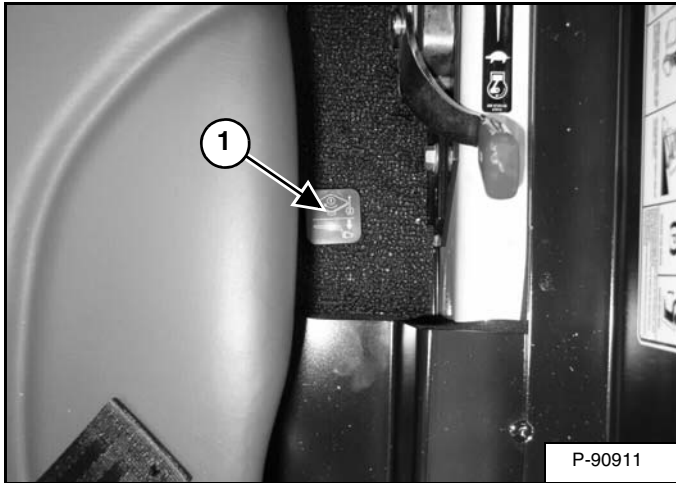

The lift arm bypass control (Item 1) [Figure 24] is used to lower the lift arms if the lift arms cannot be lowered during normal operations.

1. Sit in the operator's seat.
2. Fasten the seat belt and lower the seat bar.
3. Turn the knob (Item 1) [Figure 24] clockwise 1/4 turn.
4. Pull up and hold the knob until the lift arms lower.

PARKING BRAKE

Operation

Figure 25

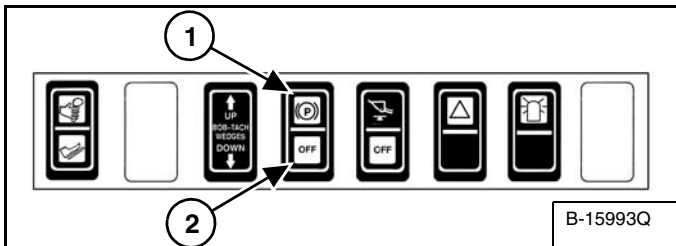

Press the top of the switch (Item 1) [Figure 25] to engage the parking brake. The red light in the switch will turn on. The traction drive system will be locked.

Press the bottom of the switch (Item 2) [Figure 25] to disengage the parking brake. The red light in the switch will turn off. The traction drive system will be unlocked.

NOTE: The PARKING BRAKE light on the left instrument panel will remain ON until the engine is started, the PRESS TO OPERATE LOADER button is pressed and the parking brake is disengaged.

TRACTION LOCK OVERRIDE

Operation

Figure 26

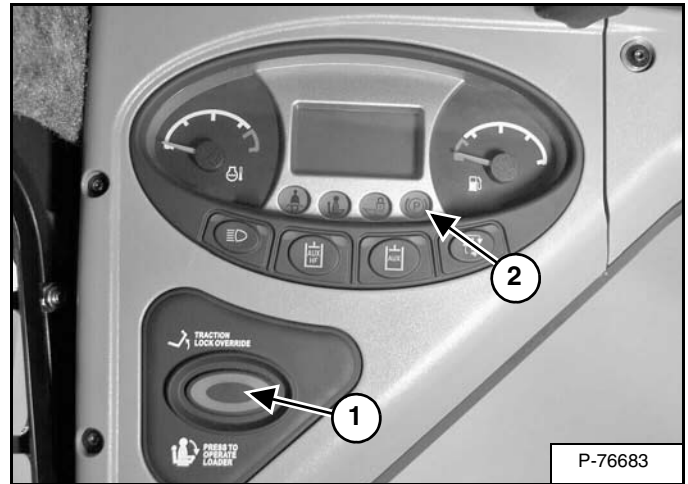

(Functions Only When The Seat Bar Is Raised And The Engine Is Running) There is a TRACTION LOCK OVERRIDE button (Item 1) [Figure 26] on the left instrument panel which will allow you to use the steering levers to move the loader forward and backward when using the backhoe attachment.

- Press the TRACTION LOCK OVERRIDE button once to unlock traction drive. The PARKING BRAKE light (Item 2) [Figure 26] will be OFF.
- Press the button a second time to lock the traction drive. The PARKING BRAKE light (Item 2) [Figure 26] will be ON.

NOTE: The TRACTION LOCK OVERRIDE button will unlock the traction drive when the seat bar is raised and the engine is running.

NOTE: The TRACTION LOCK OVERRIDE button will function if the parking brake is in the engaged or disengaged position and the engine is running. If the parking brake switch is turned ON, the red light in the parking brake switch will turn OFF when TRACTION LOCK OVERRIDE is engaged.

DRIVE RESPONSE (CONT'D)

Operation (Cont'd)

Figure 46

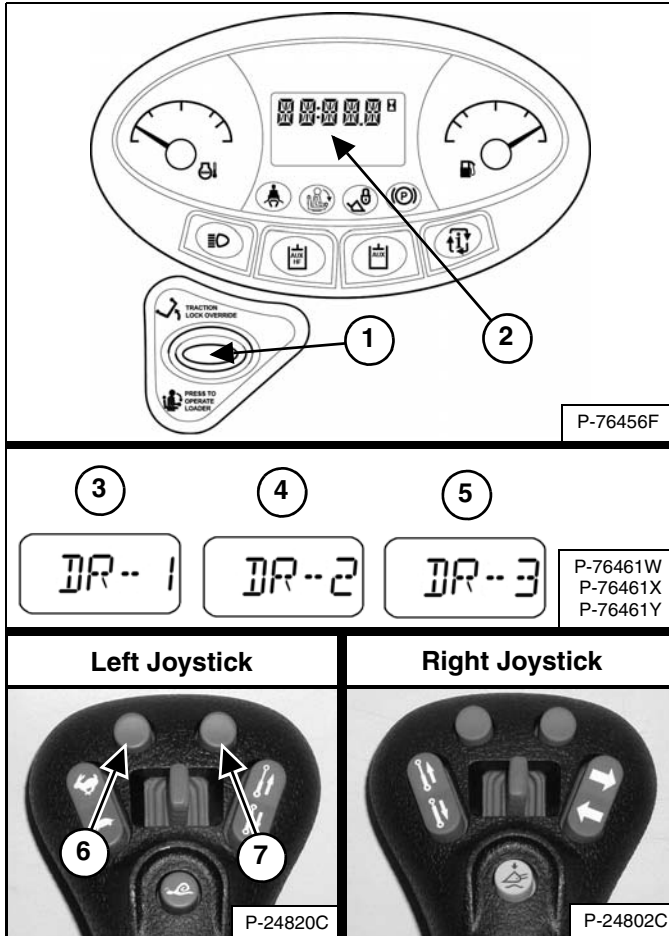

Press and hold the PRESS TO OPERATE LOADER button (Item 1) for **three seconds** to adjust the loader drive response setting. The current drive response setting will appear in the data display (Item 2) [Figure 46].

Press the upper left button (Item 6) on the left joystick to scroll down through the three settings. Press the upper right button (Item 7) on the left joystick to scroll up through the three drive response settings. The new drive response setting (Item 3, 4 or 5) will appear in the data display (Item 2) [Figure 46]. Adjustments to drive response will be effective immediately.

Figure 47

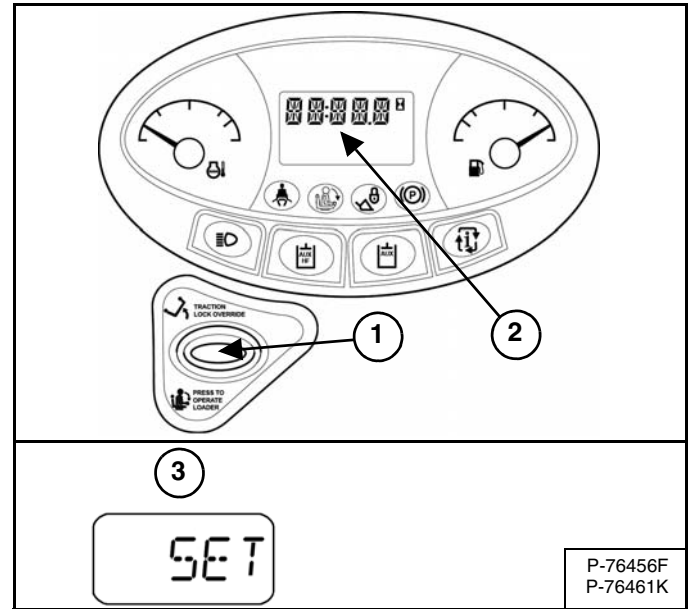

Saving The Drive Response Setting:

The current drive response setting can be saved by pressing and holding the PRESS TO OPERATE LOADER button (Item 1) for **three seconds**. [SET] (Item 3) will appear in the data display (Item 2) [Figure 47] and the machine will exit from the drive response adjustment menu.

OR

Press the PRESS TO OPERATE LOADER button to exit from the drive response adjustment menu without saving the current setting.

The current steering drift compensation setting (See STEERING DRIFT COMPENSATION on Page 50.) will appear in the data display (Item 2) [Figure 47] and the upper left and upper right buttons on the left joystick will no longer make changes to drive response.

NOTE: The last displayed drive response setting will remain in effect until the STOP button is pressed or the key is turned OFF. The machine will revert back to the last saved drive response setting the next time it is started.

Adjustments to steering drift compensation can now be made (See STEERING DRIFT COMPENSATION on Page 50.)

OR

Press the PRESS TO OPERATE LOADER button again to exit from the steering drift compensation menu.

HYDRAULIC CONTROLS (CONT'D)

**FRONT Auxiliary Hydraulics Operation
(CONTINUOUS FLOW)**

Standard And ACS (If Equipped)

Figure 65

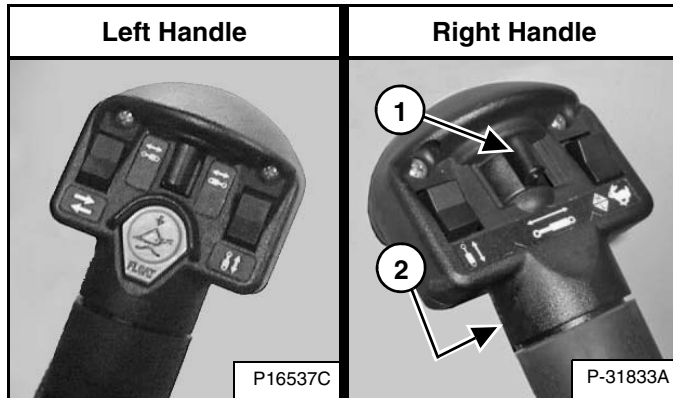

SJC (If Equipped)

Figure 66

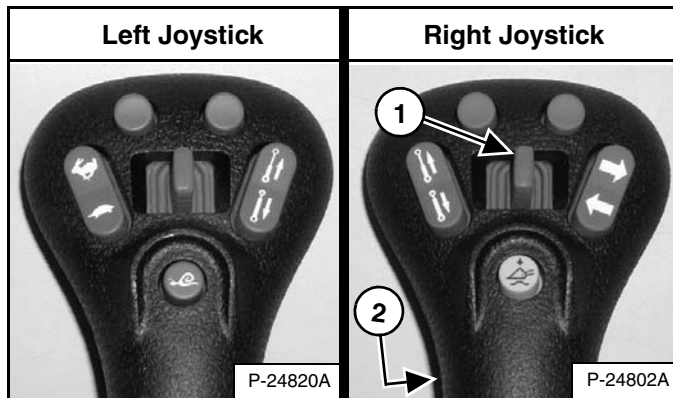

After engaging auxiliary hydraulics, press the front switch (Item 2) [Figure 65] or [Figure 66] to give the front quick couplers a constant flow of fluid with the female coupler being pressurized. (EXAMPLE: Operate a backhoe.)

REVERSE CONTINUOUS FLOW - To set reverse flow (male coupler pressurized), engage auxiliary hydraulics, then, while holding the auxiliary switch (Item 1) [Figure 65] or [Figure 66] to the left, press the front switch (Item 2) [Figure 65] or [Figure 66].

NOTE: Reverse flow can cause damage to some attachments. Use reverse flow with your attachment only if approved. See your attachment Operation & Maintenance Manual for detailed information.

To release from continuous operation, press the front switch (Item 2) [Figure 65] or [Figure 66] a second time.

NOTE: When the operator is seated and raises the seat bar, the Auxiliary Hydraulic System (Front and Rear) will deactivate.

PRE-STARTING PROCEDURE (CONT'D)

Seat Belt Adjustment

Figure 90

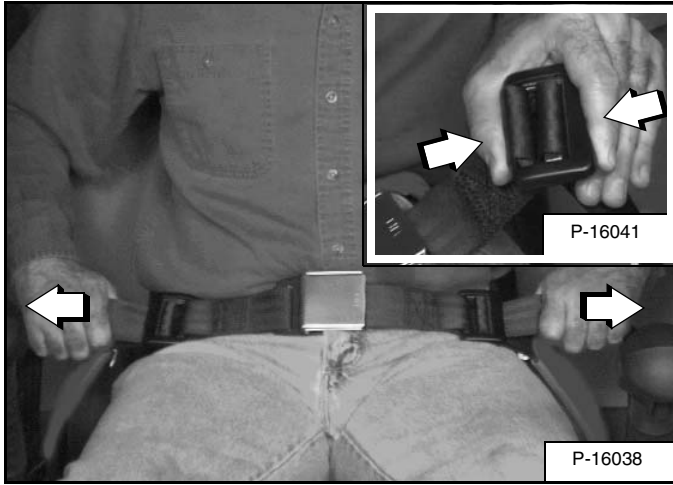

Squeeze both seat belt adjusters to release and lengthen each half of the seat belt [Figure 90].

Fasten the seat belt.

Pull the ends of the belt through the belt adjusters so that the seat belt is snug and the buckle is centered between your hips [Figure 90].

Figure 91

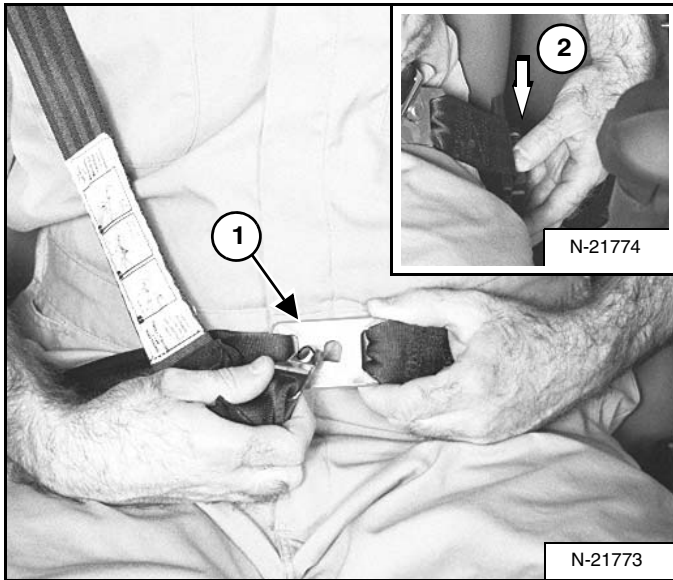

3-Point Restraint - (Option) Connect the shoulder belt to the lap belt (Item 1) [Figure 91]. Pull the lap belt across to the left side of the seat (Item 2) [Figure 91] and fasten.

The shoulder belt must be positioned over your right shoulder and lap belt over your lower hips [Figure 91].

IMPORTANT

Check the seat belt and shoulder belt retractors for correct operation.

Keep retractors clean and replace as necessary.

I-2199-0200

Seat Bar

Figure 92



Lower the seat bar and engage the parking brake [Figure 92].

Put the foot pedals or hand controls in neutral position.

NOTE: Keep your hands on the steering levers and your feet on the foot pedals (or footrests) while operating the loader.

! WARNING

AVOID INJURY OR DEATH

When operating the machine:

- Keep the seat belt fastened snugly.
- The seat bar must be lowered.
- Keep your feet on the pedal controls or footrests and hands on the controls.

W-2261-0909

COUNTERWEIGHTS

Description

Counterweights can be installed on the loader. See your Bobcat dealer for information about approved loader counterweights and configurations for your job application and attachment.

Effect On The Loader And Loader Operation

Proper operation of the loader and attachment does not change if counterweights are installed on this loader. Always follow the instructions provided in this manual when operating your loader with counterweights installed.

Counterweights installed on your loader can affect the loader and its operation in some applications. Some examples are:

- Increased machine weight.
- Increased Rated Operating Capacity (ROC).
- Harder steering.
- Accelerated or uneven track wear.
- Increased power consumption.

When To Consider Using Counterweights

Install counterweights to increase the loader Rated Operating Capacity (ROC) which could improve attachment performance in some applications. Some examples are:

- Using pallet forks with palletized loads.
- Using grapples or bale forks.
- Using buckets to handle loose material without digging.

When To Consider Removing Counterweights

Remove counterweights to increase the downward force of the attachment for better attachment performance in some applications. Some examples are:

- Digging with buckets.
- Using Hydraulic Breakers, Scrapers or Landplanes.

Accessories That Affect Machine Weight

If your loader is already equipped with accessories like Water Tanks or Rear Stabilizers, installing counterweights may not be necessary.

See your Bobcat dealer for more information about the proper use of counterweights with your attachments and accessories.

OPERATING PROCEDURE (CONT'D)

Operating With A Full Bucket

Figure 131

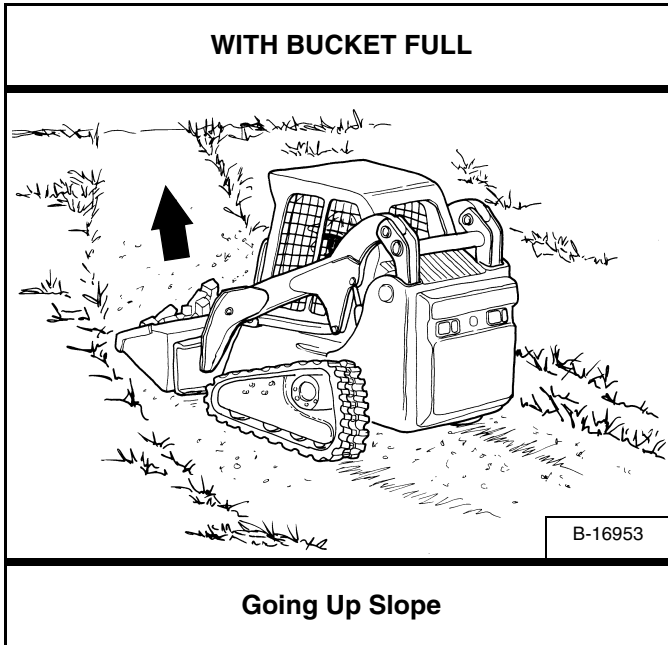
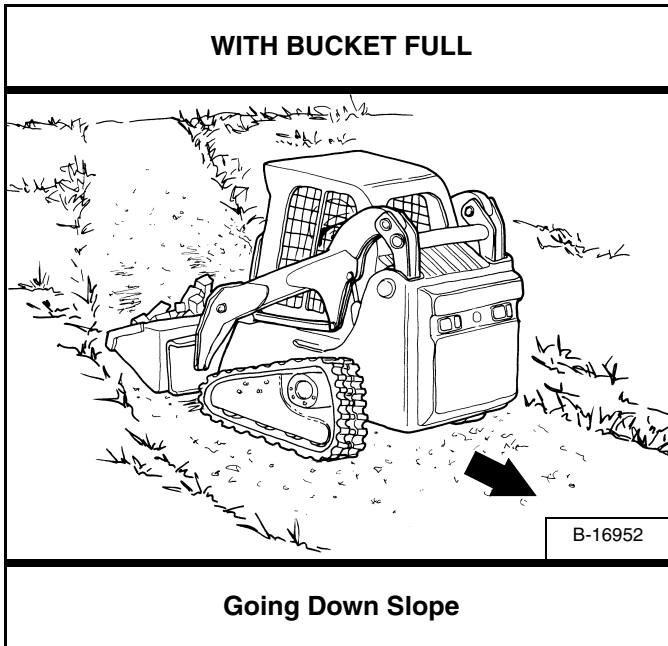

Figure 132



With a full bucket, go up or down the slope with the heavy end toward the top of the slope [Figure 131] and [Figure 132].

Operating With An Empty Bucket

Figure 133

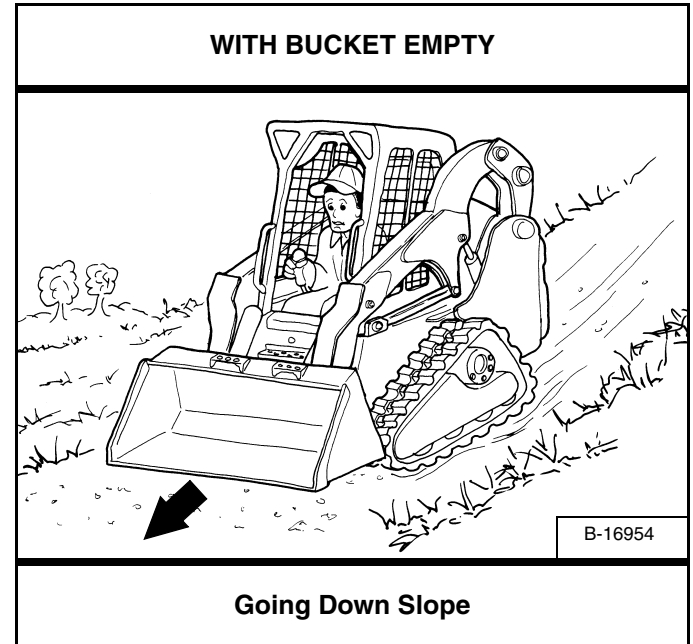
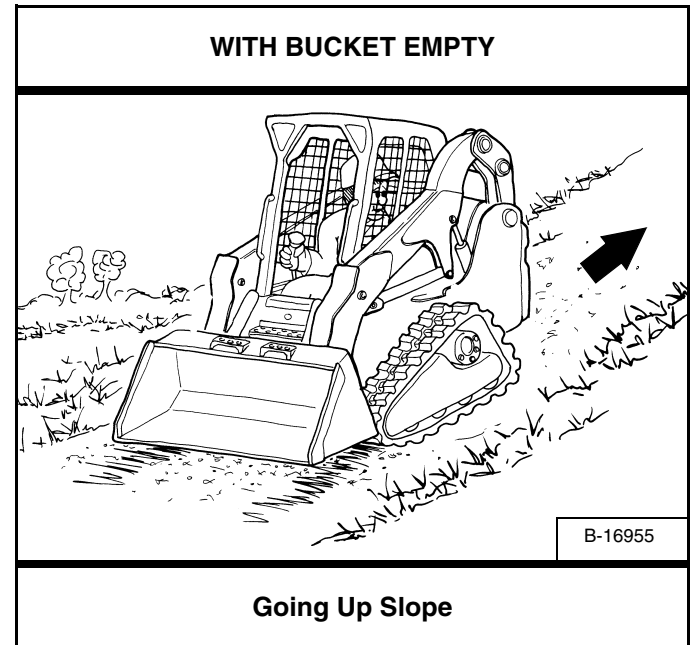

Figure 134



With an empty bucket, go down or up the slope with the heavy end toward the top of the slope [Figure 133] and [Figure 134].

Raise the bucket only high enough to avoid obstructions on rough ground.

CLICK HERE TO **DOWNLOAD** THE COMPLETE MANUAL

- Thank you very much for reading the preview of the manual.
- You can download the complete manual from: www.heydownloads.com by clicking the link below



- Please note: If there is no response to CLICKING the link, please download this PDF first and then click on it.

CLICK HERE TO **DOWNLOAD** THE COMPLETE MANUAL

TRANSPORTING THE LOADER ON A TRAILER

Loading And Unloading



AVOID SERIOUS INJURY OR DEATH

Adequately designed ramps of sufficient strength are needed to support the weight of the machine when loading onto a transport vehicle. Wood ramps can break and cause personal injury.

W-2058-0807

Be sure the transport and towing vehicles are of adequate size and capacity for weight of loader. (See Performance on Page 190.)

Figure 157

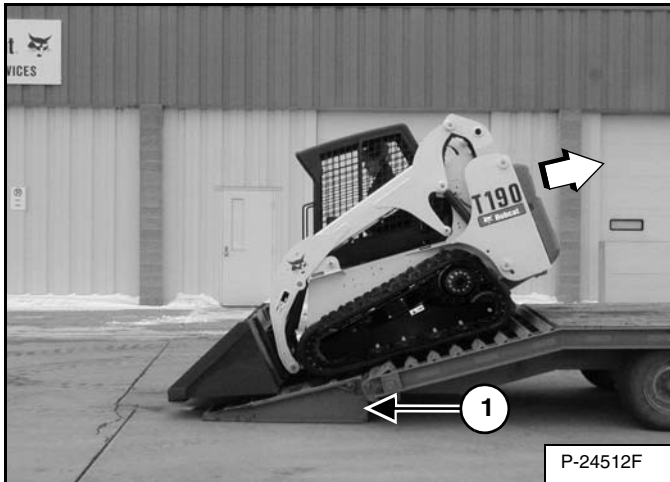

A loader with an empty bucket or no attachment must be loaded backward onto the transport vehicle [Figure 157].

The rear of the trailer must be blocked or supported (Item 1) [Figure 157] when loading or unloading the loader to prevent the front end of the trailer from raising up.

Fastening

Figure 158



Use the following procedure to fasten the Bobcat loader to the transport vehicle to prevent the loader from moving during sudden stops or when going up or down slopes [Figure 158].

- Lower the bucket or attachment to the floor.
- Stop the engine.
- Engage the parking brake.
- Install chains at the front and rear loader tie down positions [Figure 158].
- Fasten each end of the chain to the transport vehicle.

SEAT BAR RESTRAINT SYSTEM

Description

The seat bar restraint system has a pivoting seat bar with armrests.

The operator controls the use of the seat bar. The seat bar in the down position helps to keep the operator in the seat.

Models with Standard Controls have hydraulic valve spool interlocks for the lift and tilt functions. The spool interlocks require the operator to lower the seat bar in order to operate the foot pedal controls.

When the seat bar is down, the PRESS TO OPERATE LOADER button is activated and the engine is running, the lift, tilt and traction drive functions can be operated.

When the seat bar is up, the lift and tilt control pedals are locked when returned to the NEUTRAL position.

Models with Advanced Control System (ACS) have mechanical interlocks for the handles and pedals. The interlocks for the handles and pedals require the operator to lower the seat bar in order to operate the selected controls.

When the seat bar is down, the PRESS TO OPERATE LOADER button is activated and the engine is running, the lift, tilt and traction drive functions can be operated using the selected controls (handles or foot pedals).

When the seat bar is up, the handles and pedals are locked when returned to the NEUTRAL position.

Models with Selectable Joystick Controls (SJC) have electrical deactivation of joystick functions. Activation of functions require the operator to lower the seat bar.

When the seat bar is down, the PRESS TO OPERATE LOADER button is activated and the engine is running, the lift, tilt and traction drive functions can be operated.

When the seat bar is up, the joystick functions are deactivated even though the joystick does not mechanically lock.

Inspecting

Sit in the seat and fasten the seat belt. Engage the parking brake. Pull the seat bar all the way down. Start the engine. Press the PRESS TO OPERATE LOADER button.

Operate the hydraulic controls to check that both the lift and tilt functions operate correctly. Raise the lift arms until the attachment is about 600 mm (2 ft) off the ground.

Raise the seat bar. Move the hydraulic controls. Pedals and handles (if equipped) must be firmly locked in the NEUTRAL position (except joysticks). There must be no motion of the lift arms or tilt (attachment) when the controls are moved.

Lower the seat bar, press the PRESS TO OPERATE LOADER button and lower the lift arms. Operate the lift control. While the lift arms are going up, raise the seat bar. The lift arms must stop.

Lower the seat bar, press the PRESS TO OPERATE LOADER button, lower the lift arms and put the attachment flat on the ground. Stop the engine. Raise the seat bar. Operate the foot pedals and handles (if equipped) to be sure they are firmly locked in the NEUTRAL position (except joysticks).

Maintaining

See the SERVICE SCHEDULE for correct service interval. (See SERVICE SCHEDULE on Page 107.)

Figure 160

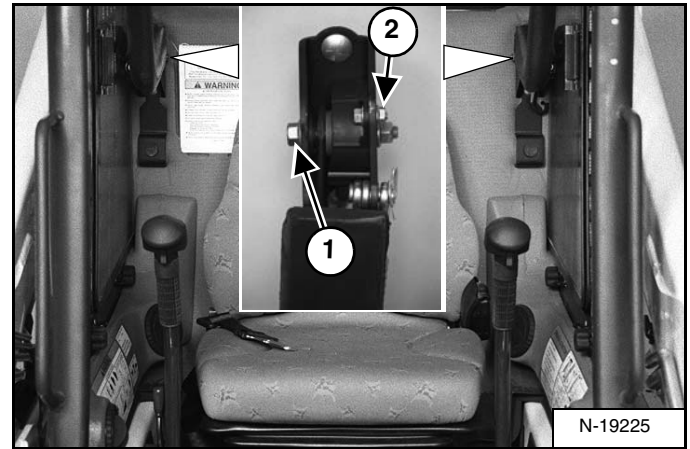

Use compressed air to clean any debris or dirt from the pivot parts. Do not lubricate. Inspect all mounting hardware. The correct hinge bolt (Item 1) torque is 34 - 38 N•m (25 - 28 ft-lb). The seat bar sensor nut (left side only) (Item 2) [Figure 160] torque is 6 - 8 N•m (50 - 70 in-lb).

If the seat bar system does not function correctly, replace parts that are worn or damaged. Use only genuine Bobcat replacement parts.



The seat bar system must deactivate the lift and tilt control functions when the seat bar is up. See your Bobcat dealer for service if hydraulic controls do not deactivate.

W-2465-111

AIR CLEANER SERVICE

Replacing Filter Elements

Figure 184



Figure 185

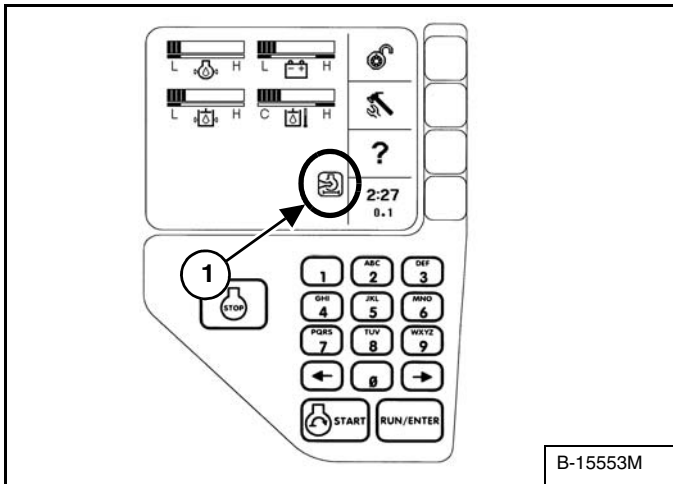

It is important to change the air filter element only when necessary. The Service indicator (Item 1) will FLASH and service code [M0117] (Air Filter Plugged) will show in the Data Display (Item 2) when the Information button (Item 3) [Figure 184] is held for two seconds.

The Air Cleaner icon on the Deluxe Instrumentation Panel, if equipped, will be ON (Item 1) [Figure 185].

Replace the inner filter every third time the outer filter is replaced or as indicated.

Outer Filter

Figure 186

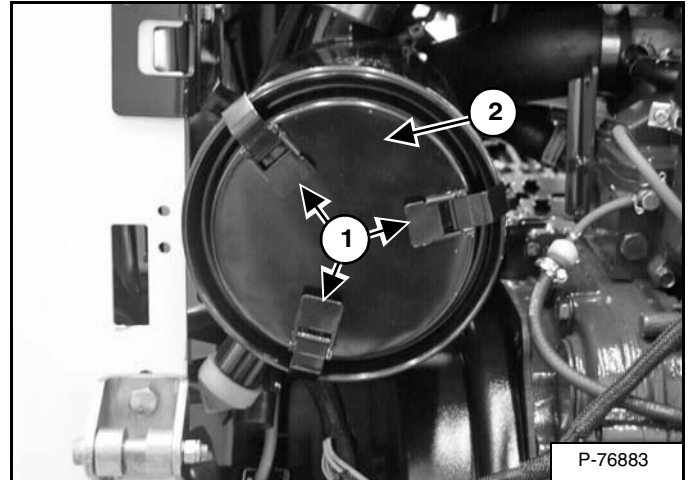

Open the latches (Item 1) and remove the dust cover (Item 2) [Figure 186].

Figure 187

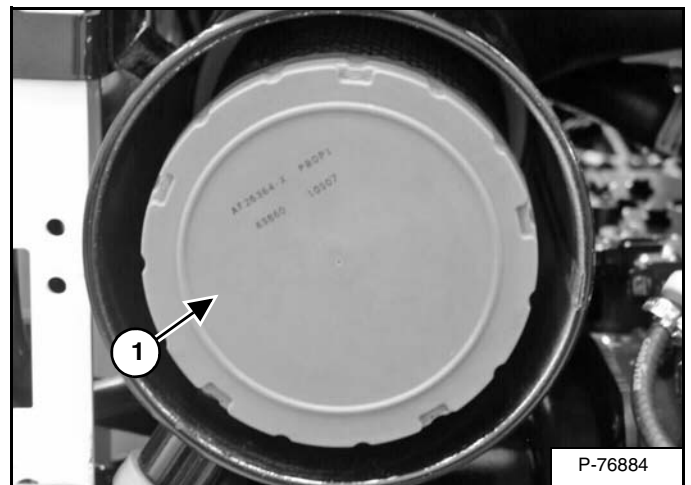

Pull the outer filter element (Item 1) [Figure 187] out and discard.

NOTE: Make sure all sealing surfaces are free of dirt and debris.

Install new filter element. Push all the way in until it contacts the base of the housing.

Install the dust cover and secure the latches [Figure 186].

ELECTRICAL SYSTEM (CONT'D)

Using A Booster Battery (Jump Starting)

If it is necessary to use a booster battery to start the engine, BE CAREFUL! There must be one person in the operator's seat and one person to connect and disconnect the battery cables.

The key switch must be OFF or the STOP button must be pressed. The booster battery must be 12 volt.

WARNING

BATTERY GAS CAN EXPLODE AND CAUSE SERIOUS INJURY OR DEATH

Keep arcs, sparks, flames and lighted tobacco away from batteries. When *jumping* from booster battery make final connection (negative) at machine frame.

Do not jump start or charge a frozen or damaged battery. Warm battery to 16°C (60°F) before connecting to a charger. Unplug charger before connecting or disconnecting cables to battery. Never lean over battery while boosting, testing or charging.

W-2066-0910

Figure 206

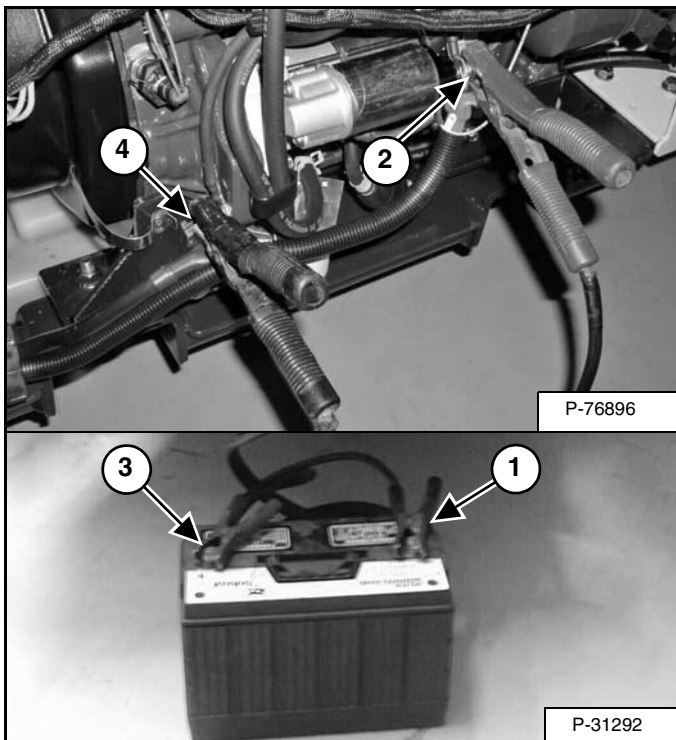

Connect the end of the first cable (Item 1) [Figure 206] to the positive (+) terminal of the booster battery. Connect the other end of the same cable (Item 2) [Figure 206] to the positive terminal on the loader starter.

Connect the end of the second cable (Item 3) [Figure 206] to the negative terminal of the booster battery. Connect the other end of the same cable (Item 4) [Figure 206] to the engine.

Keep cables away from moving parts. Start the engine. (See STARTING THE ENGINE on Page 70.)

After the engine has started, remove the negative (-) cable (Item 4) [Figure 206] first. Remove the cable from the positive terminal (Item 2) [Figure 206].

IMPORTANT

Damage to the alternator can occur if:

- Engine is operated with battery cables disconnected.
- Battery cables are connected when using a fast charger or when welding on the loader. (Remove both cables from the battery.)
- Extra battery cables (booster cables) are connected wrong.

I-2023-1285

TRACK TENSION (CONT'D)

Adjusting (Solid-Mounted Undercarriage)

Figure 226

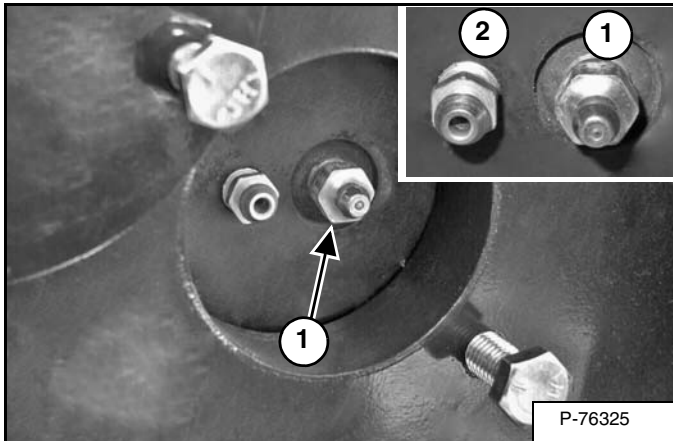

Loosen the access cover bolts and pivot the access cover open [Figure 226].

NOTE: Fittings may be oriented differently than shown. You **MUST** select the correct fitting for the task required. The grease fitting (Item 1) is used to add grease. The bleed fitting (Item 2) [Figure 226] is used to remove grease.

Increase Track Tension

Add grease to the grease fitting (Item 1) [Figure 226] until the track adjustment is correct [Figure 224] and [Figure 225].

NOTE: Do not remove grease fitting unless pressure is released using the bleed fitting. (See [Figure 227] on Page 139.)

NOTE: If replacement is necessary, always replace grease fitting (Item 1) [Figure 226] with genuine Bobcat Parts. The fitting is a special fitting designed for high pressure.

Decrease Track Tension



WARNING

HIGH PRESSURE GREASE CAN CAUSE SERIOUS INJURY

- Do not loosen grease fitting.
- Do not loosen bleed fitting more than 1 - 1/2 turns.

W-2781-0109

Figure 227

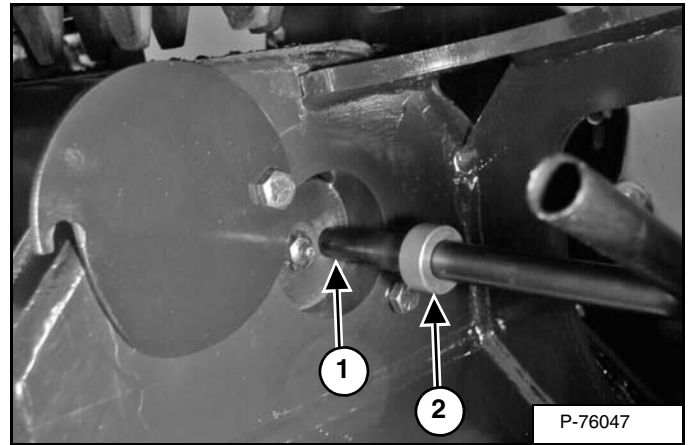

Pressure must be released from the grease cylinder to decrease track tension.

Install the bleed tool (MEL1560) on the bleed fitting (Item 1), adjust and tighten the collar (Item 2) [Figure 227] to fit behind the edge of the access cover.

Figure 228

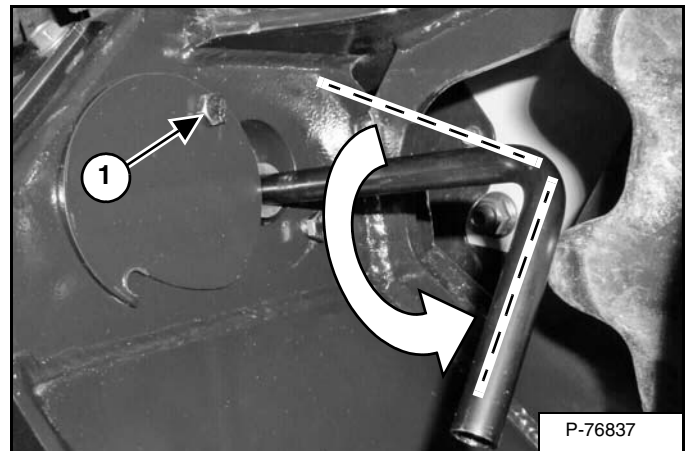

Tighten the access cover bolt (Item 1) [Figure 228] to secure the tool.

Turn the tool 1/4 turn counterclockwise and let the grease flow into a container. Release pressure [Figure 228] until the track adjustment is correct [Figure 224] and [Figure 225].

Tighten the bleed fitting. Pivot the access cover closed and tighten the access cover bolts.

Raise the loader. Remove the jackstands.

Repeat the procedure for the other track.

Dispose of grease in an environmentally safe manner.

LUBRICATING THE LOADER (CONT'D)

Lubrication Locations (Cont'd)

Figure 250

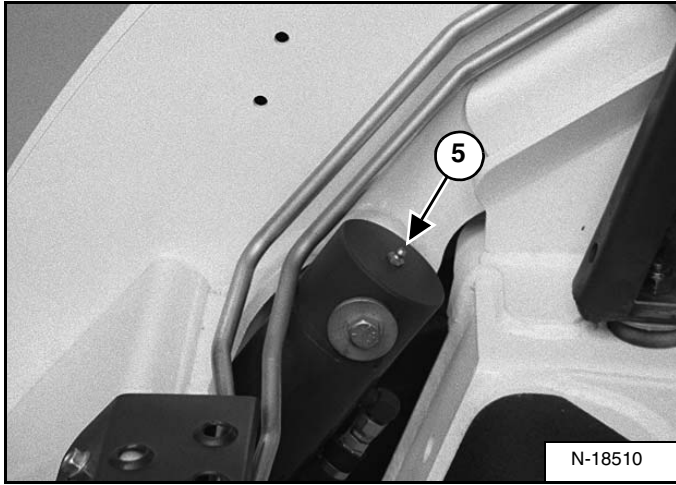

5. Tilt Cylinder Base End (Both Sides) (2) [Figure 250].

Figure 251

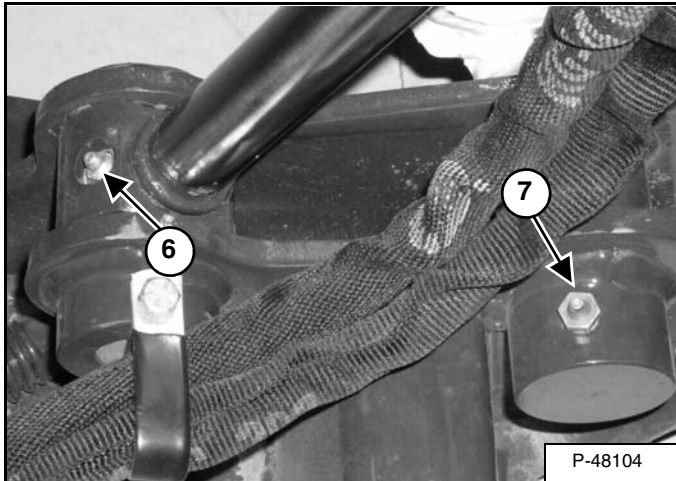

6. Tilt Cylinder Rod End (2) [Figure 251].
7. Bob-Tach Pivot Pin (Both Sides) (2) [Figure 251].

Figure 252

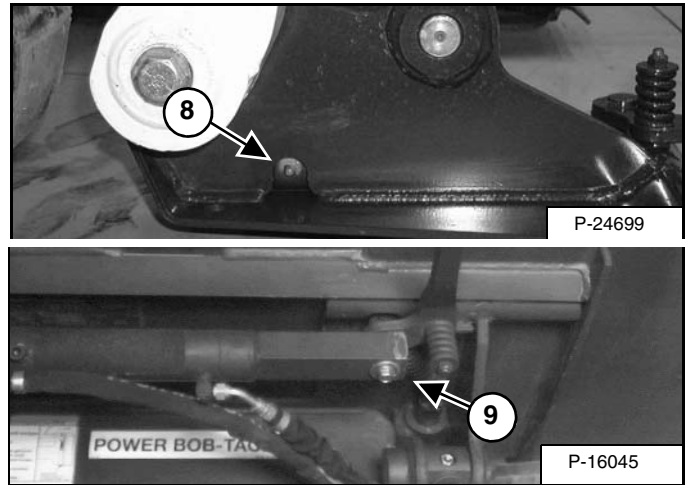

8. Bob-Tach Wedge (Both Sides) (2) [Figure 252].
9. Power Bob-Tach Cylinder (Both Sides) (2) [Figure 252]. (If Equipped)

Figure 253

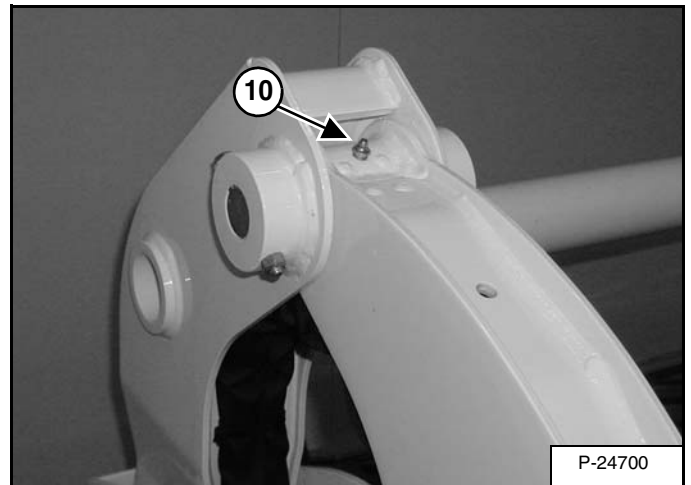

10. Lift Arm Pivot Pin (Both Sides) (2) [Figure 253].

DIAGNOSTIC SERVICE CODES (CONT'D)**Service Codes List (Cont'd)**

CODE	DESCRIPTION	CODE	DESCRIPTION
D7512	Right speed sensor not connected	D7564	Left rear steer retract short to ground
D7513	Right front wheel angle sensor stuck	D7565	Steer pressure short to ground
D7514	Left front wheel angle sensor stuck	D7566	Back-up alarm error OFF
D7515	Right rear wheel angle sensor stuck	D7567	No communication from Gateway controller
D7516	Left rear wheel angle sensor stuck	D7568	Angle sensors not calibrated
D7517	Left swash plate not in neutral	D7569	Battery voltage out of range high
D7518	Right swash plate not in neutral	D7570	Interrupted power (also occurs after software update)
D7519	Left joystick X-axis out of range high	D7571	Battery voltage out of range low
D7521	Left joystick Y-axis out of range high	D7572	Drive pump not calibrated
D7522	Right joystick Y-axis out of range high	D7573	Operating mode switch flipped while operating
D7523	Right front wheel angle sensor out of range high	D7574	Right wheel speed uncommanded motion
D7524	Left front wheel angle sensor out of range high	D7575	Left wheel speed uncommanded motion
D7525	Right rear wheel angle sensor out of range high	D7576	No communication from ACS controller
D7526	Left rear wheel angle sensor out of range high	D7577	Left speed sensor out of range high
D7527	Left swash plate out of position	D7578	Right speed sensor out of range high
D7528	Right swash plate out of position	D7579	Left speed sensor out of range low
D7529	Left joystick X-axis out of range low	D7580	Right speed sensor out of range low
D7531	Left joystick Y-axis out of range low	D7581	Right front steer retract short to battery
D7532	Right joystick Y-axis out of range low	D7582	Left front steer retract short to battery
D7533	Right front wheel angle sensor out of range low	D7583	Right rear steer retract short to battery
D7534	Left front wheel angle sensor out of range low	D7584	Left rear steer retract short to battery
D7535	Right rear wheel angle sensor out of range low	D7585	Sensor supply 1 out of range high
D7536	Left rear wheel angle sensor out of range low	D7586	Sensor supply 2 out of range high
D7537	Sensor supply 1 out of range low	D7587	Software update required
D7538	Sensor supply 2 out of range low	D7588	Switched power stuck ON
D7539	Left swash plate sensor out of range high	D7589	Switched power error OFF
D7540	Left swash plate sensor out of range low	D7590	Drive calibration performed
D7541	Right swash plate sensor out of range high	D7591	Left swash plate sensor reversed
D7542	Right swash plate sensor out of range low	D7592	Right swash plate sensor reversed
D7543	Left forward drive solenoid error ON	D7593	Right speed sensor unresponsive
D7544	Left reverse drive solenoid error ON	D7594	Left speed sensor unresponsive
D7545	Right forward drive solenoid error ON	D7595	Left speed sensor reversed
D7546	Right reverse drive solenoid error ON	D7596	Right speed sensor reversed
D7547	Right front steer extend short to battery	D7597	Controller programmed
D7548	Left front steer extend short to battery	D7598	In drive calibration mode
D7549	Right rear steer extend short to battery	D7599	In angle calibration mode
D7550	Left rear steer extend short to battery		
D7551	Steer pressure short to battery	H1121	Boost Sensor out of range high
D7552	Back-up alarm error ON	H1122	Boost Sensor out of range low
D7553	Left forward drive solenoid error OFF	H1221	Right Primary out of range high
D7554	Left reverse drive solenoid error OFF	H1222	Right Primary out of range low
D7555	Right forward drive solenoid error OFF	H1224	Right Primary not in neutral
D7556	Right reverse drive solenoid error OFF	H1321	Left Primary out of range high
D7557	Right front steer extend short to ground	H1322	Left Primary out of range low
D7558	Right front steer retract short to ground	H1324	Left Primary not in neutral
D7559	Left front steer extend short to ground	H2005	Boost solenoid short to battery
D7560	Left front steer retract short to ground	H2006	Boost solenoid short to ground
D7561	Right rear steer extend short to ground	H2007	Boost solenoid open circuit
D7562	Right rear steer retract short to ground	H2032	Boost solenoid overcurrent
D7563	Left rear steer extend short to ground	H2205	Pressure control solenoid short to battery

MACHINE SIGN TRANSLATIONS







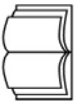

MACHINE SIGN TRANSLATIONS	171
Service Schedule (6734534)	171
Warning (6728540)	174
Warning (6718396)	175
Danger (6809511)	175
Warning (6718397)	175
Warning (6737189)	176
Warning (6725370)	176
Warning (6737248)	176
Lift Arm Support Device (6719018)	177
Warning (7131520)	178
Important (6560573)	179
Warning (7131521)	180
Warning (7160879)	181
Warning (6577754)	182
Danger (6718392)	183
Danger (6718393)	183
Warning (6718391)	183
Danger (6717343)	183
Warning (7168019)	184
Warning (7142141)	185

Warning (7131520) (Cont'd)

Important (6560573)

AVERTISSEMENT

RISQUE DE DE BLESSURES GRAVES, VOIRE MORTELLES

<p>UTILISEZ JAMAIS LA CHARGEUSE SANS DISPOSER DES INSTRUCTIONS. LISEZ LE MANUEL ET LE GUIDE DE L'OPÉRATEUR ET D'ENTRETIEN.</p> 	<p>UTILISEZ L'ARCEAU DE SIEGE. ATTACHEZ SOIGNÉMENT VOTRE CEINTURE DE SÉCURITÉ.</p> 	<p>GARDEZ LES PIEDS SUR LES REPOSE-PIEDS.</p> 	<p>ARRÊTEZ LE MOTEUR</p> 
<p>NE MARCHEZ PAS ET NE LANCEZ PAS LA CHARGEUSE QUAND LES BRAS SONT RELÈVÉS. DÉCHARGEZ ET VIREZ L'OPÉRATEUR SUR UN SOL PLAT NE DÉPASSEZ JAMAIS LA CAPACITÉ OPÉRATIONNELLE (VOIR AUTOCOLLANT SUR LA CHARGEUSE).</p> 	<p>NE MODIFIEZ JAMAIS L'ÉQUIPEMENT ET N'UTILISEZ JAMAIS D'ACCESSOIRES NON APPROUVÉS PAR BORGAT COMPANY.</p> 	<p>ENCLÉNCHEZ LE PIED</p> 	<p>RELEVEZ L'ARCEAU DE SIEGE</p> 

VERROUILLAGE DU FLOTTEMENT

Appuyer sur le bouton (1) de flottement du manipulateur droit pendant l'abaissement des bras de levage.



MANIPULATEUR DROIT - ISO

ABAISSÉMENT DES BRAS

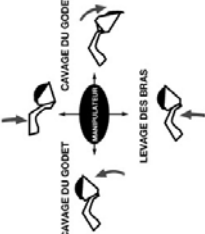

MANIPULATEUR DROIT - H

MARCHE AVANT CÔTÉ DROIT

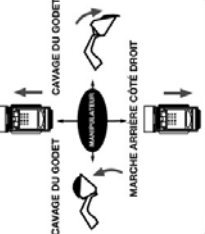

67472 0W

7131520 fr

IMPORTANT

THIS MACHINE IS FACTORY EQUIPPED WITH A U.S.D.A. FORESTRY SERVICE APPROVED SPARK ARRESTOR EXHAUST SYSTEM.

THE SPARK ARRESTOR MUFFLER, IF EQUIPPED, MUST BE CLEANED TO KEEP IT IN WORKING CONDITION. THE SPARK ARRESTOR MUFFLER MUST BE SERVICED BY DUMPING THE SPARK CHAMBER EVERY 100 HRS OF OPERATION.

ON SOME MODELS, THE TURBOCHARGER FUNCTIONS AS THE SPARK ARRESTOR AND MUST OPERATE CORRECTLY FOR PROPER SPARK ARRESTOR FUNCTION.

IF THIS MACHINE IS OPERATED ON FLAMMABLE FOREST, BRUSH, OR GRASS COVERED LAND, IT MUST BE EQUIPPED WITH A SPARK ARRESTOR ATTACHED TO THE EXHAUST SYSTEM AND MAINTAINED IN WORKING ORDER. FAILURE TO DO SO WILL BE IN VIOLATION OF CALIFORNIA STATE LAW, SECTION 4442. PRC. REFER TO LOCAL LAWS AND REGULATIONS FOR SPARK ARRESTOR REQUIREMENTS.

SEE THE OPERATION AND MAINTENANCE MANUAL FOR MORE INSTRUCTIONS.

62554 SW 6560573G enUS

IMPORTANTE

ESTA MÁQUINA ESTÁ EQUIPADA DE FÁBRICA CON UN SILENCIADOR DEL SISTEMA PARACHISPAS APROBADO POR EL SERVICIO DE SILVICULTURA DE LA U.S.D.A.

EL SILENCIADOR DEL SISTEMA PARACHISPAS, SI ESTÁ EQUIPADO, DEBE LIMPIARSE PARA MANTENERSE EN CONDICIONES DE TRABAJO. ASÍ MISMO, SE LE DEBE DAR SERVICIO VACIANDO LA CÁMARA DE CHISPAS CADA 100 HORAS DE OPERACIÓN.

EN ALGUNOS MODELOS, EL TURBOCARGADOR FUNCIONA COMO EL PARACHISPAS Y DEBE OPERAR CORRECTAMENTE COMO TAL.

SI VA A OPERAR ESTA MÁQUINA EN BOSQUES INFLAMABLES O EN TERRENOS CUBIERTOS DE RAMAS O CÉSPED, DEBE DISPONER DE UN SISTEMA PARACHISPAS EN EL SISTEMA DE ESCAPE Y MANTENERLO EN BUENAS CONDICIONES DE TRABAJO. NO CUMPLIR ESTA ADVERTENCIA INFRINGIRÁ LA SECCIÓN 442 DE LA LEY DEL ESTADO DE CALIFORNIA. CONSULTE LAS LEYES Y REGLAMENTOS LOCALES ACERCA DE LOS REQUERIMIENTOS PARA UTILIZAR SISTEMAS PARACHISPAS.

PARA MAYORES INSTRUCCIONES, CONSULTE EL MANUAL DE OPERACIÓN Y MANTENIMIENTO.

62554 SW 6560573G enUS

IMPORTANT

CETTE MACHINE EST ÉQUIPÉE EN USINE D'UN SYSTÈME D'ÉCHAPPEMENT PARE-ÉTINCELLES APPROUVÉ PAR LE SERVICE AMÉRICAIN DES EAUX ET FORÊTS (U.S.D.A. FORESTRY SERVICE).

LE CAS ÉCHÉANT, LE SILENCIEUX PARE-ÉTINCELLES DOIT ÊTRE ENTRETIENU POUR ASSURER SON BON FONCTIONNEMENT. CET ENTRETIEN CONSISTE À REMPLACER LA CHAMBRE À ÉTINCELLES TOUTES LES 100 HEURES D'EXPLOITATION.

SUR CERTAINS MODÈLES, LA FONCTION DE PARE-ÉTINCELLES EST ASSURÉE PAR LE TURBOCOMPRESSEUR QUI DOIT FONCTIONNER CORRECTEMENT POUR REMPLIR SA FONCTION.

SI VOUS UTILISEZ LA MACHINE EN FORÊT, SUR TERRAIN HERBEUX OU DANS DES TAILLIS, VOUS DEVEZ ÉQUIPER LE SYSTÈME D'ÉCHAPPEMENT D'UN PARE-ÉTINCELLES ET LE GARDER EN BON ÉTAT DE FONCTIONNEMENT. LE NON RESPECT DE CETTE OBLIGATION CONTREVIENT À LA LOI DE L'ÉTAT DE CALIFORNIE, SECTION 4442 PRC. VEUILLEZ VOUS RÉFÉRER AUX LOIS ET RÉGLEMENTS LOCAUX POUR CONNAÎTRE LES EXIGENCES EN MATIÈRE DE PARE-ÉTINCELLES.

VEUILLEZ CONSULTER LE MANUEL DE L'OPÉRATEUR ET D'ENTRETIEN POUR DES INSTRUCTIONS COMPLÉMENTAIRES.

62554 SW 6560573G enUS

(T190) LOADER SPECIFICATIONS

Machine Dimensions

- Dimensions are given for loader equipped with standard track and 68 in. Construction & Industrial bucket and may vary with other bucket types.
- Where applicable, specification conform to SAE or ISO standards and are subject to change without notice.

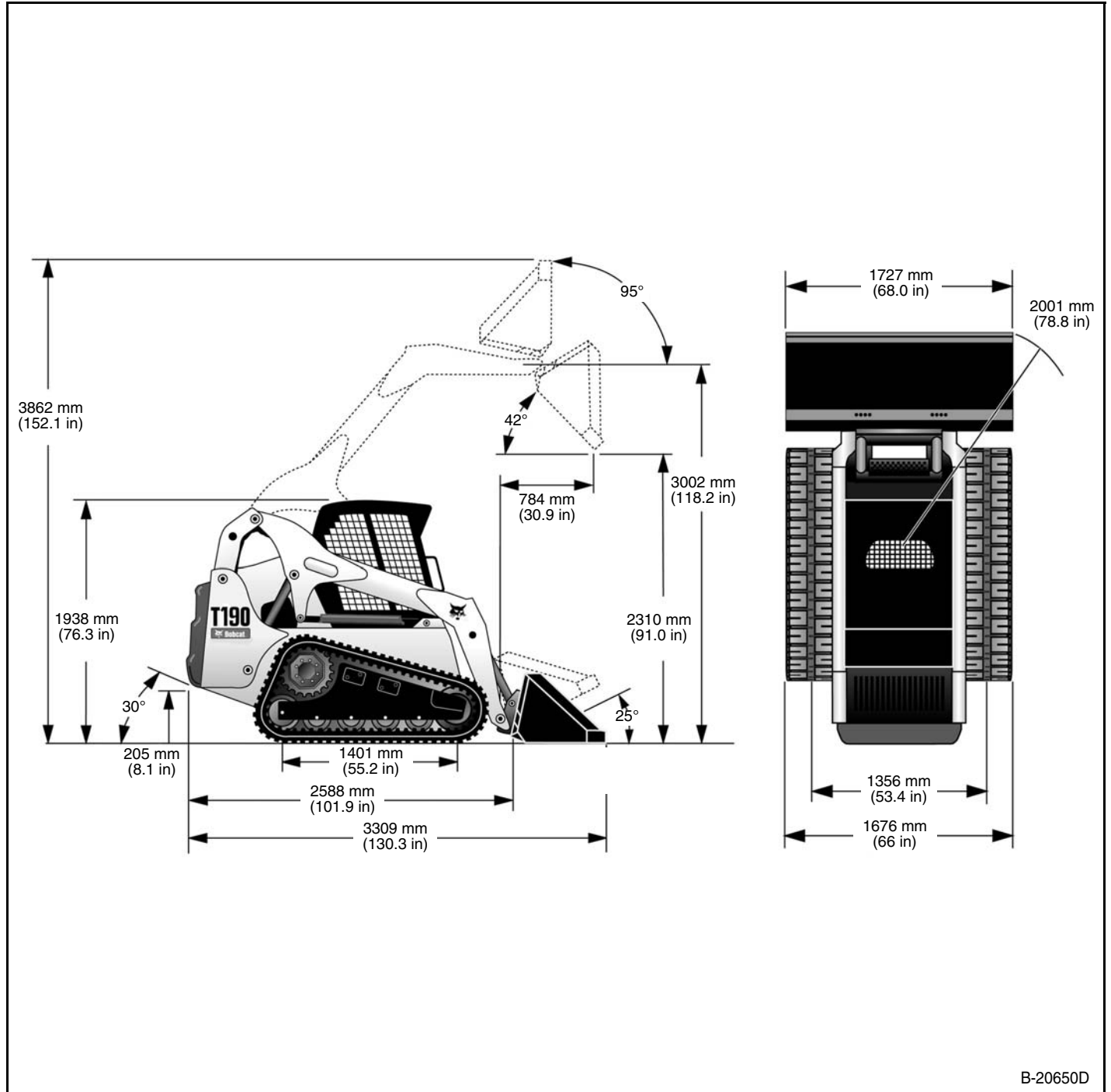

B-20650D

Changes of structure or weight distribution of the loader can cause changes in control and steering response and can cause failure of the loader parts.

CLICK HERE TO **DOWNLOAD** THE COMPLETE MANUAL

- Thank you very much for reading the preview of the manual.
- You can download the complete manual from: www.heydownloads.com by clicking the link below



- Please note: If there is no response to CLICKING the link, please download this PDF first and then click on it.

CLICK HERE TO **DOWNLOAD** THE COMPLETE MANUAL