



# Bobcat®

---

## Operation & Maintenance Manual S175 Skid-Steer Loader

---

S/N A3L520001 & Above

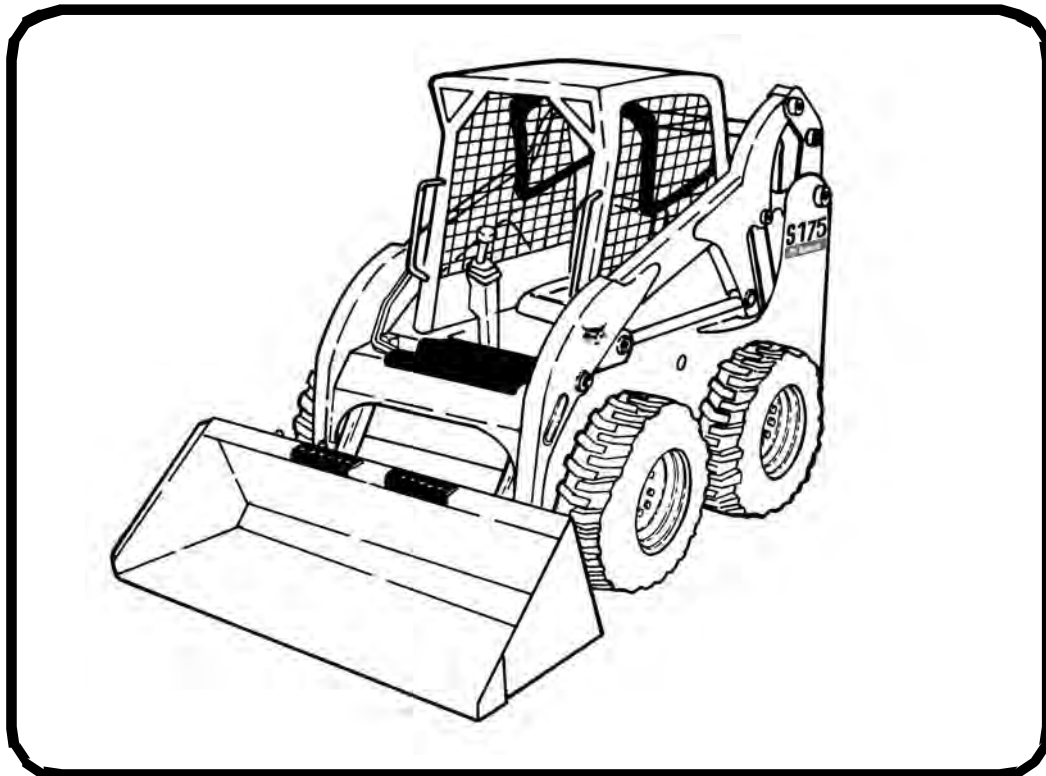

EQUIPPED WITH  
BOBCAT INTERLOCK  
CONTROL SYSTEM (BICS™)



Printed in U.S.A.



© Bobcat Company 2013

CLICK HERE TO **DOWNLOAD** THE COMPLETE MANUAL

- Thank you very much for reading the preview of the manual.
- You can download the complete manual from: [www.heydownloads.com](http://www.heydownloads.com) by clicking the link below



- Please note: If there is no response to CLICKING the link, please download this PDF first and then click on it.

CLICK HERE TO **DOWNLOAD** THE COMPLETE MANUAL

## LOADER IDENTIFICATION

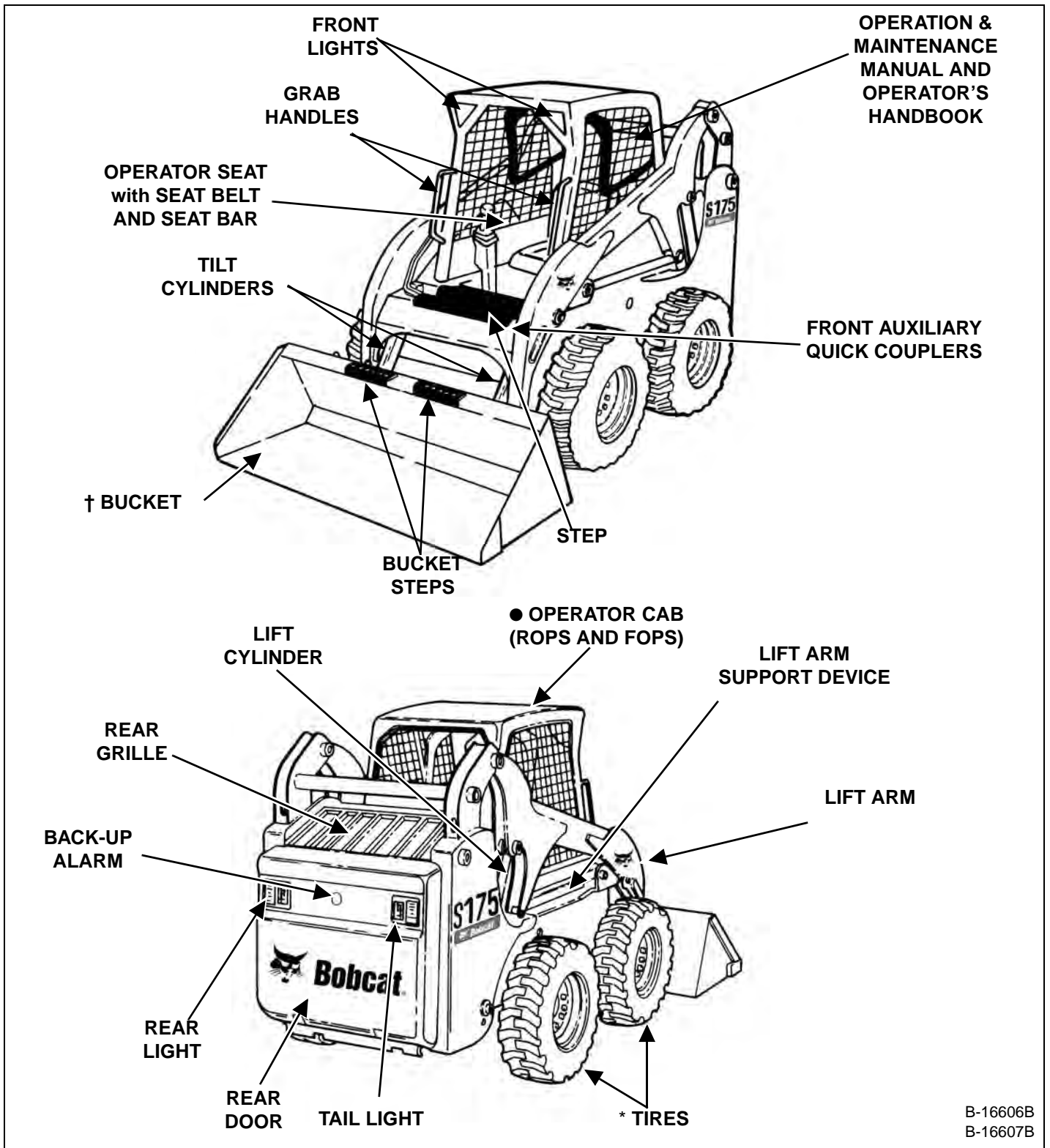

\* TIRES - The Bobcat loader is factory equipped with standard tires.

† BUCKETS - Several different buckets and other attachments are available for the Bobcat loader.

● ROPS - Roll-Over Protective Structure per ISO 3471 and FOPS - Falling Object Protective Structure per ISO 3449, Level I. Level II is available.

## PUBLICATIONS AND TRAINING RESOURCES

The following publications are also available for your Bobcat loader. You can order them from your Bobcat dealer.

For the latest information on Bobcat products and the Bobcat Company, visit our Web site at [www.training.bobcat.com](http://www.training.bobcat.com) or [www.bobcat.com](http://www.bobcat.com).

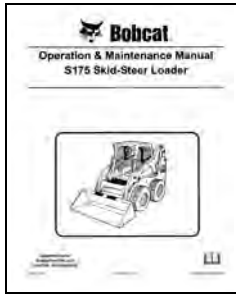

### OPERATION & MAINTENANCE MANUAL

6986983

Complete instructions on the correct operation and the routine maintenance of your Bobcat loader.

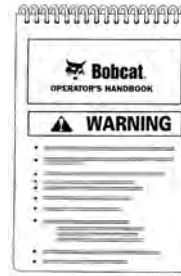

### OPERATOR'S HANDBOOK

6986651

Gives basic operation instructions and safety warnings.



### SAFETY MANUAL

6556500 (English and Spanish)

Gives basic safety procedures and warnings for your Bobcat loader.



### OPERATOR SAFETY DVD

6904762 (English and Spanish)

DVD gives basic safety instructions for many Bobcat products including loaders.



### SKID-STEER LOADER OPERATOR TRAINING COURSE

6901726 (English)

6902289 (Spanish)

Introduces operator to step-by-step basics of skid-steer loader operation.



### SKID-STEER LOADER SERVICE SAFETY TRAINING COURSE

6900641

Introduces service technicians to step-by-step basics of proper and safe skid-steer loader maintenance and servicing procedures.



### SERVICE MANUAL

6987035

Complete maintenance instructions for your Bobcat loader.



### LOADER SAFETY VIDEO

(Mobile device with quick response code application required)

Scan the code above to watch the loader safety video or view at [www.training.bobcat.com](http://www.training.bobcat.com).

## INSTRUMENT PANEL IDENTIFICATION (CONT'D)

### Left Panel (Cont'd)

REF. NO.	DESCRIPTION	FUNCTION / OPERATION
1	ENGINE TEMPERATURE GAUGE	Shows the engine coolant temperature.
2	LEFT TURN SIGNAL (Option)	Indicates left turn signals are ON.
3	GENERAL WARNING	Malfunction with one or more machine functions. (See Service Codes*)
4	TWO-SPEED (Option)	High range selected.
5	ENGINE MALFUNCTION	Engine malfunction or failure. (See Service Codes*)
6	ENGINE COOLANT TEMPERATURE	Engine coolant temperature high or sensor error.
7	DISPLAY SCREEN	Displays information. (See Display Screen in this manual.)
8	SEAT BELT	Instructs operator to fasten seat belt. Remains lit for 45 seconds.
9	SEAT BAR	The light comes on when the seat bar is UP.
10	LIFT & TILT VALVE	The light comes on when the lift and tilt functions cannot be operated.
11	PARKING BRAKE	The light comes on when the loader cannot be driven.
12	RIGHT TURN SIGNAL (Option)	Indicates right turn signals are ON.
13	SHOULDER BELT (Option)	Instructs operator to fasten shoulder belt when operating in high range. Remains lit while in high range.
14	HYDRAULIC SYSTEM MALFUNCTION	Hydraulic system malfunction or failure. (See Service Codes*)
15	FUEL	Fuel level low or sensor error.
16	FUEL GAUGE	Shows the amount of fuel in the tank.
17	LIGHTS	Press once for FRONT work lights and REAR taillights. (Left green LED will light.) Press a second time to add REAR work lights. (Left and right green LEDs will light.) Press a third time to turn all lights off. (Left and right green LEDs will be off.) Press and hold five seconds to display software version in display screen.
18	HIGH-FLOW (Option)	Press once to engage the HIGH-FLOW auxiliary hydraulics. (Left green LED will light.) Press a second time to disengage.
19	AUXILIARY HYDRAULICS	Press once to engage the auxiliary hydraulics. (Left green LED will light.) Press a second time to disengage.
20	INFORMATION	Cycles through (after each button press): <ul style="list-style-type: none"> <li>• Hourmeter (On start up)</li> <li>• Engine rpm</li> <li>• Battery voltage</li> <li>• Maintenance clock (Press and hold for seven seconds when displayed to reset the maintenance clock.)</li> <li>• Service codes*</li> </ul>
21	TRACTION LOCK OVERRIDE	Functions only when the seat bar is raised and the engine is running. Press once to unlock the brakes. Allows you to use the steering levers or joystick(s) to move the loader forward or backward when using the backhoe attachment. (See TRACTION LOCK OVERRIDE in this manual.) Press a second time to lock the brakes.
22	PRESS TO OPERATE LOADER	Press to activate the BICS™ when the seat bar is down and operator is seated in operating position. Button will light. Press and hold <b>three seconds</b> to engage Drive Response and Steering Drift Compensation. (See DRIVE RESPONSE and STEERING DRIFT COMPENSATION in this manual.)
23	ALARM	The alarm beeps when Error, Warning or Shutdown conditions exist.

\* See SYSTEM SETUP & ANALYSIS for Service Code description. (See DIAGNOSTIC SERVICE CODES on Page 149.)

## LIFT ARM BYPASS CONTROL

### Operation

Figure 23

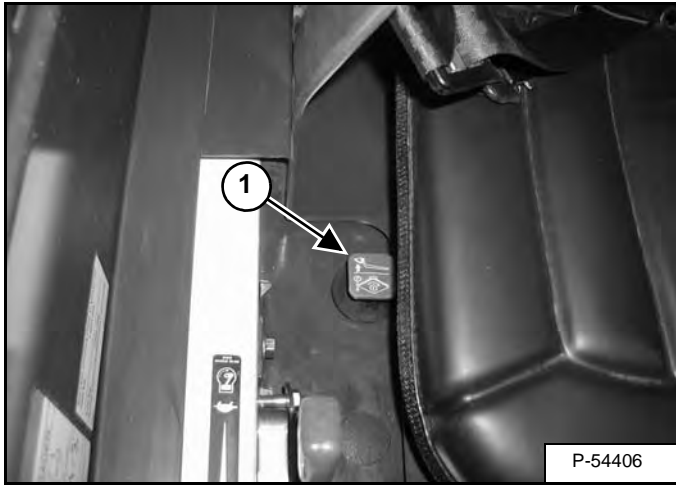

The lift arm bypass control (Item 1) [Figure 23] is used to lower the lift arms if the lift arms cannot be lowered during normal operations.

1. Sit in the operator's seat.
2. Fasten the seat belt and lower the seat bar.
3. Turn the knob (Item 1) [Figure 23] clockwise 1/4 turn.
4. Pull up and hold the knob until the lift arms lower.

## PARKING BRAKE

### Operation

Figure 24

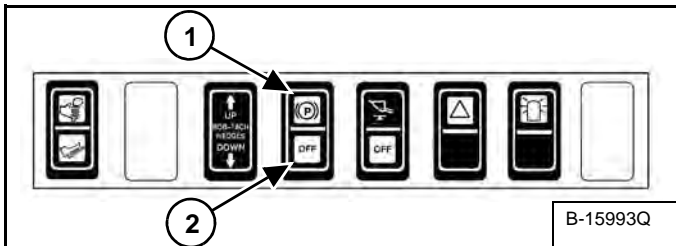

Press the top of the switch (Item 1) [Figure 24] to engage the parking brake. The red light in the switch will turn on. The traction drive system will be locked.

Press the bottom of the switch (Item 2) [Figure 24] to disengage the parking brake. The red light in the switch will turn off. The traction drive system will be unlocked.

**NOTE:** The **PARKING BRAKE** light on the left instrument panel will remain **ON** until the engine is started, the **PRESS TO OPERATE LOADER** button is pressed and the parking brake is disengaged.

## TRACTION LOCK OVERRIDE

### Operation

Figure 25

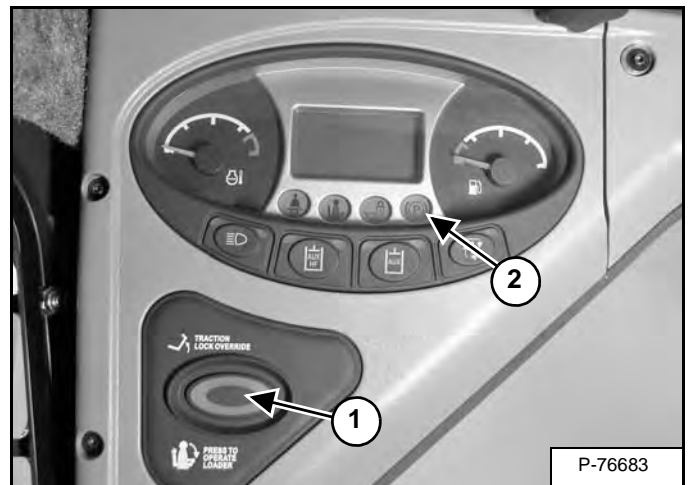

(Functions Only When The Seat Bar Is Raised And The Engine Is Running) There is a TRACTION LOCK OVERRIDE button (Item 1) [Figure 25] on the left instrument panel which will allow you to use the steering levers to move the loader forward and backward when using the backhoe attachment.

- Press the TRACTION LOCK OVERRIDE button once to unlock traction drive. The PARKING BRAKE light (Item 2) [Figure 25] will be OFF.
- Press the button a second time to lock the traction drive. The PARKING BRAKE light (Item 2) [Figure 25] will be ON.

**NOTE:** The TRACTION LOCK OVERRIDE button will unlock the traction drive when the seat bar is raised and the engine is running.

**NOTE:** The TRACTION LOCK OVERRIDE button will function if the parking brake is in the engaged or disengaged position and the engine is running. If the parking brake switch is turned ON, the red light in the parking brake switch will turn OFF when TRACTION LOCK OVERRIDE is engaged.

## DRIVE RESPONSE

Drive Response is available on SJC equipped machines.

**NOTE: An upgrade to the loader software may be required if this feature does not function as described in this manual. See your Bobcat dealer to update your machine software version if necessary.**

### Description

Drive Response changes how responsive (more or less) the loader drive and steering systems are when the operator moves the joystick(s).

Drive Response can be changed by the operator for different drive response preferences and various job conditions and attachment use.

**NOTE: Changes to drive response do not affect braking or stopping the loader.**

There are three drive response settings:

- **[DR-1]** provides a smooth responsive reaction to joystick movement. (Drive only)
- **[DR-2]** is the default setting and provides a normal responsive reaction to joystick movement. (Drive only)
- **[DR-3]** provides a quick responsive reaction to joystick movement. (Drive only)

## Operation

**NOTE: Changes CANNOT be performed until the seat bar is lowered, the engine is started and the PRESS TO OPERATE LOADER button is pressed to activate the BICS™.**

Perform pre-starting and starting procedures:

1. Fasten seat belt.
2. Lower seat bar.
3. Place joysticks in neutral position.
4. Start the engine.
5. Press the PRESS TO OPERATE LOADER button.
6. Current drive response setting will be displayed briefly in the data display.

**NOTE: Raising the seat bar or changing control mode (ISO / H) will cause the machine to disengage from drive response. The last displayed setting will remain in effect until the STOP button is pressed or the key is turned OFF.**

## HYDRAULIC CONTROLS (CONT'D)

### FRONT Auxiliary Hydraulics Operation

Figure 64

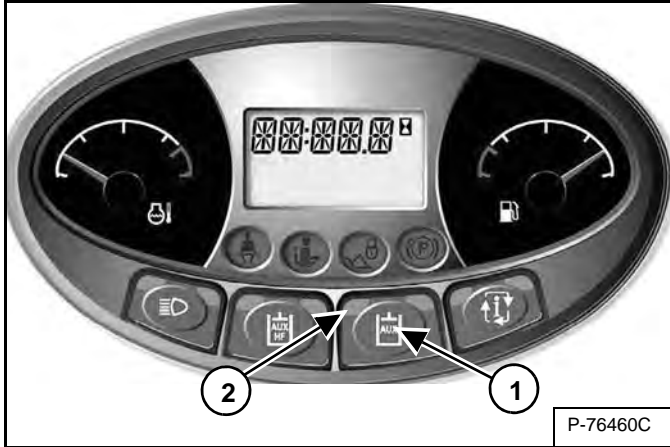

Press the auxiliary hydraulics button (Item 1) [Figure 64] once to engage auxiliary hydraulics.

The light (Item 2) [Figure 64] will be ON.

Standard And ACS (If Equipped)

Figure 65

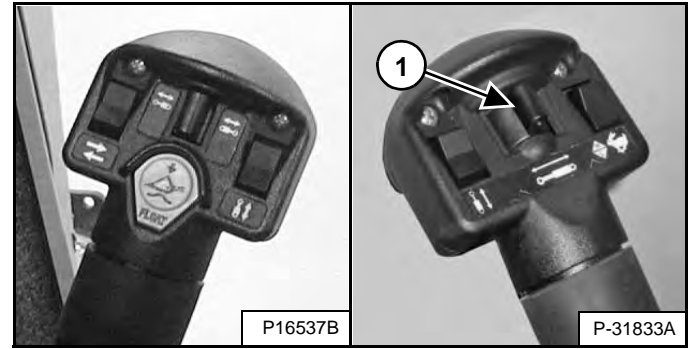

SJC (If Equipped)

Figure 66

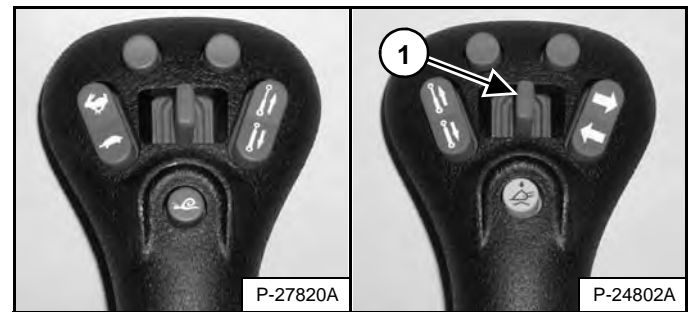

Move the front auxiliary hydraulic switch (Item 1) [Figure 65] or [Figure 66] to the right or left to change the fluid flow direction of the front quick couplers. If you move the switch half-way, the auxiliary functions move at approximately one-half speed; release the switch to stop auxiliary functions. (EXAMPLE: Open and close grapple teeth.)

To disengage, press the auxiliary hydraulics button (Item 1) [Figure 64] again.

The light (Item 2) [Figure 64] will be OFF.

**NOTE: When the operator is seated and raises the seat bar, the Auxiliary Hydraulic System (Front and Rear) will deactivate.**

## PRE-STARTING PROCEDURE (CONT'D)

### Seat Belt Adjustment

Figure 91

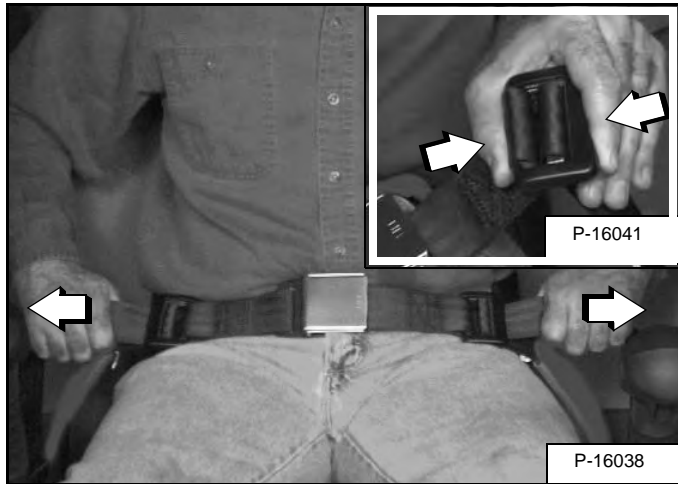

Squeeze both seat belt adjusters to release and lengthen each half of the seat belt [Figure 91].

Fasten the seat belt.

Pull the ends of the belt through the belt adjusters so that the seat belt is snug and the buckle is centered between your hips [Figure 91].

Figure 92

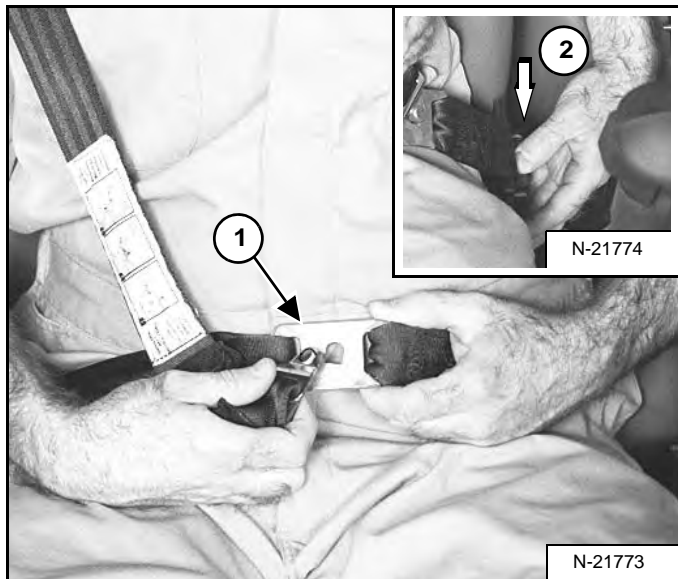

**3-Point Restraint** - (Option and Loaders with Two-Speed)  
Connect the shoulder belt to the lap belt (Item 1) [Figure 92]. Pull the lap belt across to the left side of the seat (Item 2) [Figure 92] and fasten.

The shoulder belt must be positioned over your right shoulder and lap belt over your lower hips [Figure 92].

# IMPORTANT

Check the seat belt and shoulder belt retractors for correct operation.

Keep retractors clean and replace as necessary.

I-2199-0200

### Seat Bar

Figure 93



Lower the seat bar and engage the parking brake [Figure 93].

Put the foot pedals or hand controls in neutral position.

**NOTE:** Keep your hands on the steering levers and your feet on the foot pedals (or footrests) while operating the loader.

# ! WARNING

## AVOID INJURY OR DEATH

When operating the machine:

- Keep the seat belt fastened snugly.
- The seat bar must be lowered.
- Keep your feet on the pedal controls or footrests and hands on the controls.

W-2261-0909

## STOPPING THE ENGINE AND LEAVING THE LOADER

### Procedure

Stop the loader on level ground.

Fully lower the lift arms and put the attachment flat on the ground.

Figure 113



Pull the engine speed control fully backward [Figure 113] to decrease the engine speed.

Engage the parking brake.

Figure 114

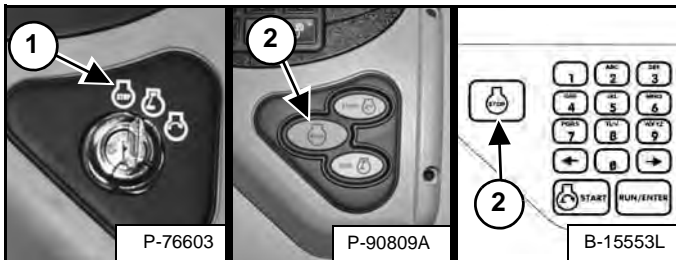

Turn the key switch to the STOP position (Item 1) or press the STOP button (Item 2) [Figure 114].

**NOTE: If the loader lights are ON, they will remain ON for approximately 90 seconds after turning the loader OFF.**

Raise the seat bar and make sure the lift and tilt functions are deactivated.

Unbuckle the seat belt.

Remove the key from the switch (Standard Key Panel) to prevent operation of the loader by unauthorized personnel.

**NOTE: Activating the Password Lockout Feature on machines with the Keyless Start Panel or the Deluxe Instrumentation Panel allows operation of the loader without using a password. (See Password Lockout Feature on Page 157.) or (See Password Lockout Feature on Page 159.)**

Figure 115



Exit the loader using grab handles, safety tread and steps (maintaining a 3-point contact) [Figure 115].

**! WARNING**

**AVOID INJURY OR DEATH**

Before you leave the operator's seat:

- Lower the lift arms and put the attachment flat on the ground.
- Stop the engine.
- Engage the parking brake.
- Raise the seat bar.
- Move all controls to the NEUTRAL / LOCKED position to make sure the lift, tilt and traction drive functions are deactivated.

The seat bar system must deactivate these functions when the seat bar is up. See your Bobcat dealer for service if controls do not deactivate.

W-2463-1110

CLICK HERE TO **DOWNLOAD** THE COMPLETE MANUAL

- Thank you very much for reading the preview of the manual.
- You can download the complete manual from: [www.heydownloads.com](http://www.heydownloads.com) by clicking the link below



- Please note: If there is no response to CLICKING the link, please download this PDF first and then click on it.

CLICK HERE TO **DOWNLOAD** THE COMPLETE MANUAL

## OPERATING PROCEDURE (CONT'D)

### Filling And Emptying The Bucket (Foot Pedals)

#### Filling

Figure 134

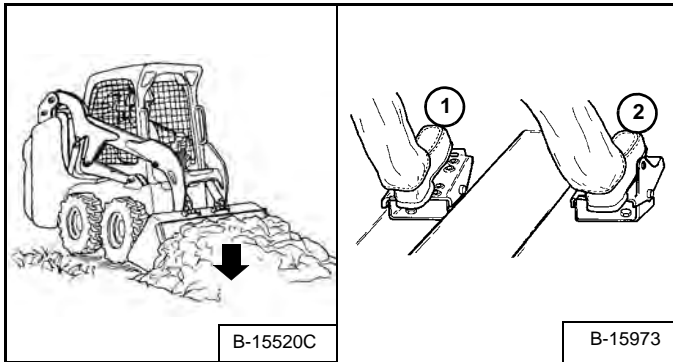
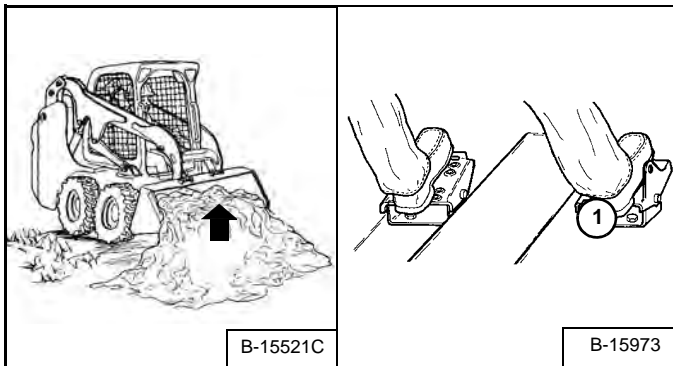

Figure 135



Lower the lift arms all the way (Item 1) [Figure 134].

Tilt the bucket forward (Item 2) [Figure 134] until the cutting edge of the bucket is on the ground.

Drive slowly forward into the material. Tilt the bucket backward (Item 1) [Figure 135] all the way when the bucket is full.

Drive backward away from the material.

## ! WARNING

Load, unload and turn on flat level ground. Do not exceed Rated Operating Capacity (ROC) shown on sign (decal) in cab. Failure to obey warnings can cause the machine to tip or rollover and cause injury or death.

W-2056-1112

#### Emptying

Figure 136

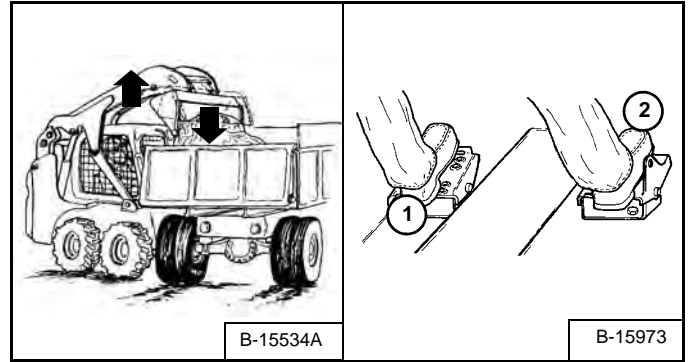

Keep the bucket low when moving to the area where you want to empty the bucket.

Raise the lift arms (Item 1) [Figure 136]. Level the bucket (Item 2) [Figure 136] while raising the lift arms to help prevent material from falling off the back of the bucket.

Drive forward slowly until the bucket is over the top of the truck box or bin.

Empty the bucket (Item 2) [Figure 136]. If all the material is near the side of the truck or bin, use the bucket tilt to move it to the other side.

## ! WARNING

Never dump over an obstruction, such as a post, that can enter the operator cab. The machine could tip forward and cause injury or death.

W-2057-0694

## PREVENTIVE MAINTENANCE

MAINTENANCE SAFETY .....	103
SERVICE SCHEDULE .....	105
Chart .....	105
BOBCAT INTERLOCK CONTROL SYSTEM (BICS™) .....	106
Inspecting The BICS™ (Engine STOPPED - Key ON) .....	106
Inspecting Deactivation Of The Auxiliary Hydraulics System (Engine STOPPED - Key ON) .....	106
Inspecting The Seat Bar Sensor (Engine RUNNING) .....	106
Inspecting The Traction Lock (Engine RUNNING) .....	106
Inspecting The Lift Arm Bypass Control .....	106
Inspecting Deactivation Of Lift And Tilt Functions (ACS And SJC) .....	106
SEAT BAR RESTRAINT SYSTEM .....	107
Description .....	107
Inspecting .....	107
Maintaining .....	107
SEAT BELT .....	108
Inspection And Maintenance .....	108
LIFT ARM SUPPORT DEVICE .....	109
Installing .....	109
Removing .....	110
BACK-UP ALARM SYSTEM .....	111
Description .....	111
Inspecting .....	111
Adjusting Switch Position .....	111
OPERATOR CAB .....	112
Description .....	112
Raising .....	112
Lowering .....	113
Cab Door Sensor .....	114
REAR DOOR (TAILGATE) .....	115
Opening And Closing .....	115
Adjusting .....	115
REAR GRILLE .....	115
Removing .....	115
Installing .....	115

## LIFT ARM SUPPORT DEVICE

### Installing

# ! WARNING

Never work on a machine with the lift arms up unless the lift arms are secured by an approved lift arm support device. Failure to use an approved lift arm support device can allow the lift arms or attachment to fall and cause injury or death.

Service lift arm support device if damaged or if parts are missing. Using a damaged lift arm support or with missing parts can cause lift arms to drop causing injury or death.

W-2572-0407

# ! DANGER



P-90328

### AVOID DEATH

- Disconnecting or loosening any hydraulic tubeline, hose, fitting, component or a part failure can cause lift arms to drop.
- Keep out of this area when lift arms are raised unless supported by an approved lift arm support. Replace if damaged.

D-1009-0409

Remove attachment from the loader. (See Installing And Removing The Attachment (Hand Lever Bob-Tach) on Page 82.) **OR** (See Installing And Removing The Attachment (Power Bob-Tach) on Page 84.)

Figure 161

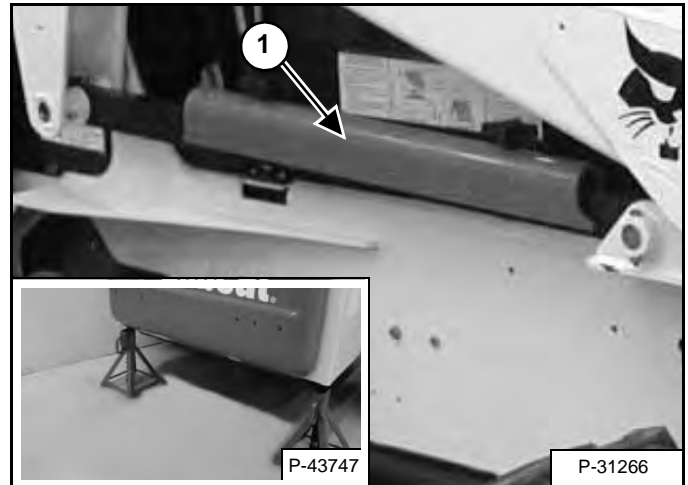

Put jackstands under the rear corners of the loader frame (Inset) [Figure 161].

Remove the lift arm support device (Item 1) [Figure 161] from the storage position.

The operator must stay in the operator seat with the seat belt fastened and the seat bar lowered until the lift arm support device is installed.

Start the engine and raise the lift arms all the way up.

Figure 162



Have a second person install the lift arm support device over the rod of one of the lift cylinders [Figure 162].

The lift arm support device must be tight against the cylinder rod.

## FUEL SYSTEM

### Fuel Specifications

Use only clean, high quality diesel fuel, Grade No. 2 or Grade No. 1.

The following is one suggested blending guideline which should prevent fuel gelling during cold temperatures:

TEMPERATURE C° (F°)	NO. 2	NO. 1
-9° (+15°)	100%	0%
Down to -29° (-20°)	50%	50%
Below -29° (-20°)	0%	100%

At a minimum, low sulfur diesel fuel must be used in this machine. Low sulfur is defined as 500 mg/kg (500 ppm) sulfur maximum.

The following fuels may also be used in this machine:

- Ultra low sulfur diesel fuel. Ultra low sulfur is defined as 15 mg/kg (15 ppm) sulfur maximum.
- Biodiesel blend fuel - Must contain no more than five percent biodiesel mixed with low sulfur or ultra low sulfur petroleum based diesel. This is commonly marketed as B5 blended diesel fuel. B5 blended diesel fuel must meet ASTM D975 (US Standard) or EN590 (EU Standard) specifications.

### Biodiesel Blend Fuel

Biodiesel blend fuel has unique qualities that should be considered before using in this machine:

- Cold weather conditions can lead to plugged fuel system components and hard starting.
- Biodiesel blend fuel is an excellent medium for microbial growth and contamination which can cause corrosion and plugging of fuel system components.
- Use of biodiesel blend fuel may result in premature failure of fuel system components, such as plugged fuel filters and deteriorated fuel lines.
- Shorter maintenance intervals may be required, such as cleaning the fuel system and replacing fuel filters and fuel lines.
- Using biodiesel blended fuels containing more than five percent biodiesel can affect engine life and cause deterioration of hoses, tubelines, injectors, injector pump and seals.

Apply the following guidelines if biodiesel blend fuel is used:

- Ensure the fuel tank is as full as possible at all times to prevent moisture from collecting in the fuel tank.
- Ensure that the fuel tank cap is securely tightened.
- Biodiesel blend fuel can damage painted surfaces, remove all spilled fuel from painted surfaces immediately.
- Drain all water from the fuel filter daily before operating the machine.
- Do not exceed engine oil change interval. Extended oil change intervals can cause engine damage.
- Before vehicle storage; drain the fuel tank, refill with 100% petroleum diesel fuel, add fuel stabilizer and run the engine for at least 30 minutes.

**NOTE: Biodiesel blend fuel does not have long term stability and should not be stored for more than three months.**

## HYDRAULIC / HYDROSTATIC SYSTEM

### Checking And Adding Fluid

Check the hydraulic / hydrostatic fluid level every day before starting the work shift.

Put the loader on a level surface, lower the lift arms and tilt the Bob-Tach fully back.

Stop the engine.

Figure 207

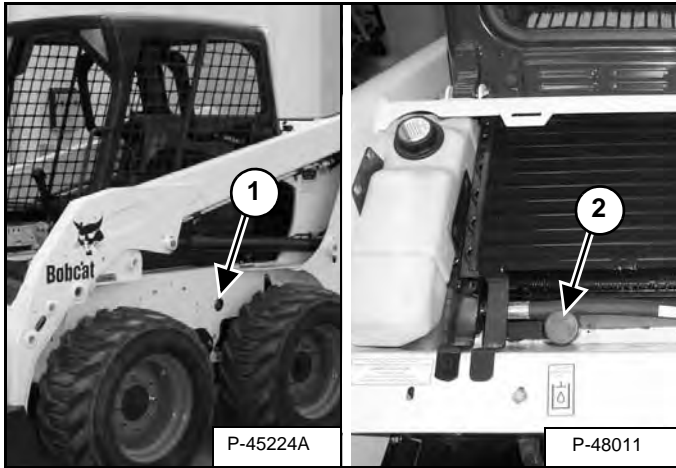

Check the fluid level in the sight gauge (Item 1) [Figure 207].

Open the rear door and remove the rear grille. Remove the fill cap (Item 2) [Figure 207].

Add fluid as needed to bring the level to the center of the sight gauge. Install the fill cap (Item 2) [Figure 207].

Install the rear grille and close the rear door.

## Hydraulic / Hydrostatic Fluid Chart

Figure 208

### HYDRAULIC / HYDROSTATIC FLUID RECOMMENDED ISO VISCOSITY GRADE (VG) AND VISCOSITY INDEX (VI)

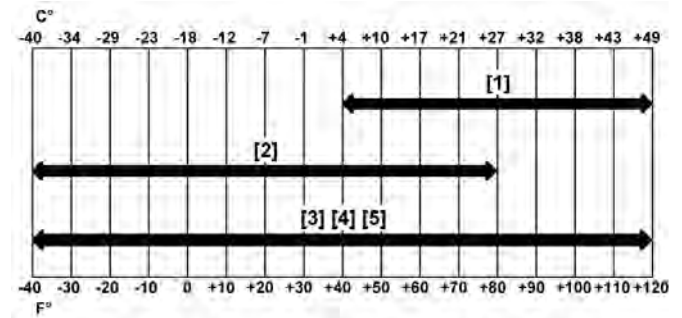

### TEMPERATURE RANGE ANTICIPATED DURING MACHINE USE

- [1] VG 100; Minimum VI 130
- [2] VG 46; Minimum VI 150
- [3] BOBCAT All-Season Fluid
- [4] BOBCAT Synthetic Fluid
- [5] BOBCAT Biodegradable Hydraulic / Hydrostatic Fluid (Unlike biodegradable fluids that are vegetable based, Bobcat biodegradable fluid is formulated to prevent oxidation and thermal breakdown at operating temperatures.)

Use only recommended fluid in the hydraulic system [Figure 208]. (See Hydraulic System on Page 183.)

## ALTERNATOR BELT

### Belt Adjustment

Stop the engine.

Raise the operator cab. (See Raising on Page 112.)

**Figure 227**

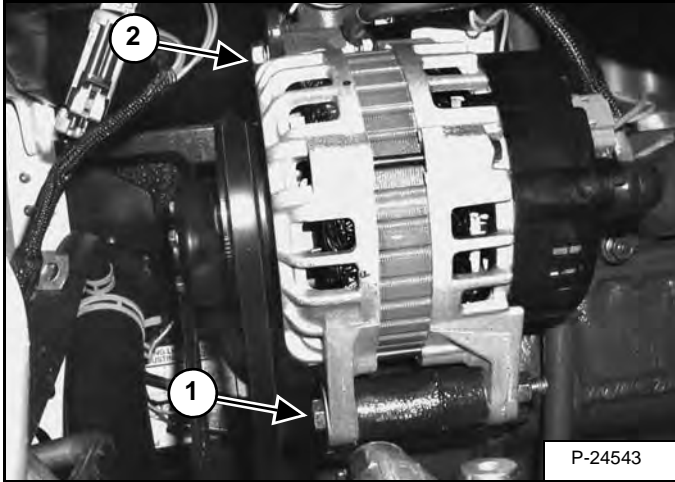

Loosen the alternator mounting bolt (Item 1) **[Figure 227]**.

Loosen the adjustment bolt (Item 2) **[Figure 227]**.

Move the alternator until the belt has 8,0 mm (5/16 in) movement at the middle of the belt span with 66 N (15 lb) of force.

Tighten the adjustment bolt and mounting bolt.

Lower the operator cab. (See Lowering on Page 113.)

### Belt Replacement

Loosen the alternator mounting and adjustment bolts (Item 1 and 2) **[Figure 227]** and loosen the belt all the way.

Remove the belt and install a new belt.

Adjust the belt as shown above.

## DIAGNOSTIC SERVICE CODES

### Viewing Service Codes

The Service Codes will aid your dealer in diagnosing conditions which can damage your machine.

Figure 245

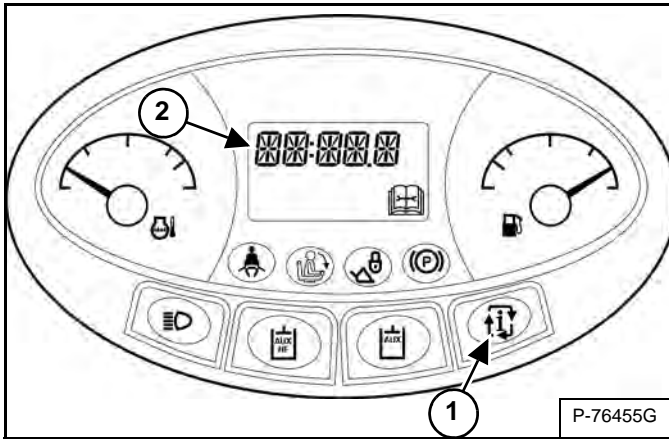

Press the INFORMATION button (Item 1) to cycle the DATA DISPLAY (Item 2) [Figure 245] until the service code screen is displayed. If more than one SERVICE CODE is present, the codes will scroll on the DATA DISPLAY.

**NOTE: Corroded or loose grounds can cause multiple service codes and / or abnormal symptoms. All instrument panel lights flashing, alarm sounding, headlights and taillights flashing, could indicate a bad ground. The same symptoms could apply if the voltage is low, such as loose or corroded battery cables. If you observe these symptoms, check grounds and positive leads first.**

### Deluxe Instrumentation Panel

The optional Deluxe Instrumentation Panel offers an additional view of service codes.

Figure 246

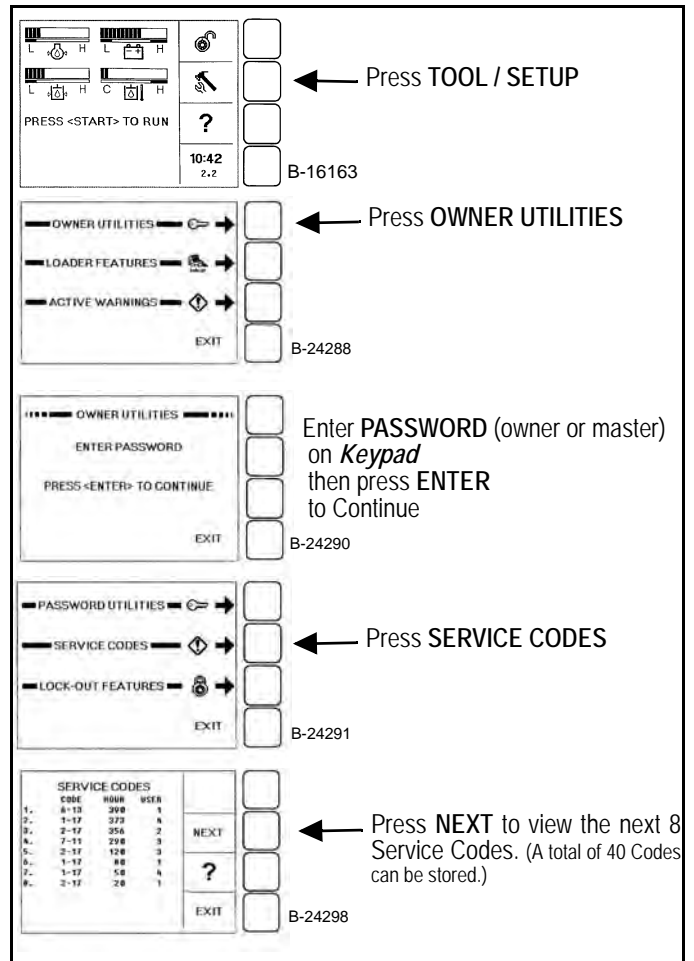

The Display Panel will list the Code Number, (CODE) hourmeter reading when the error occurred (HOUR), and the User (USER) who was logged in to operate the machine when the error occurred [Figure 246].

A total of 40 Codes can be stored. When more than 40 codes occur, the oldest code will disappear and the newest code will be in the number 1 position.

# PASSWORD SETUP (DELUXE INSTRUMENTATION PANEL) (CONT'D)

## Changing The User Passwords

Figure 254

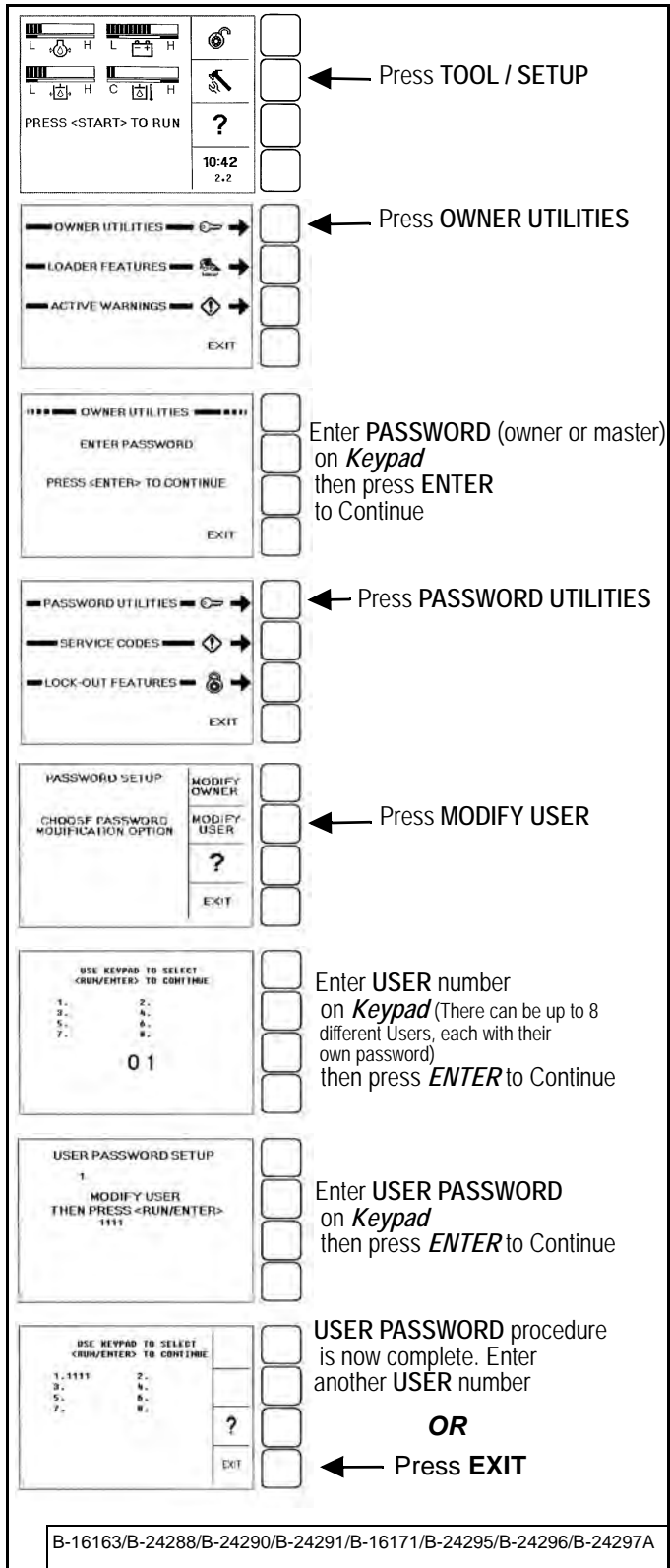

## Password Lockout Feature

This feature allows the owner to unlock the password feature so that a password does not need to be used every time the engine is started.

Figure 255

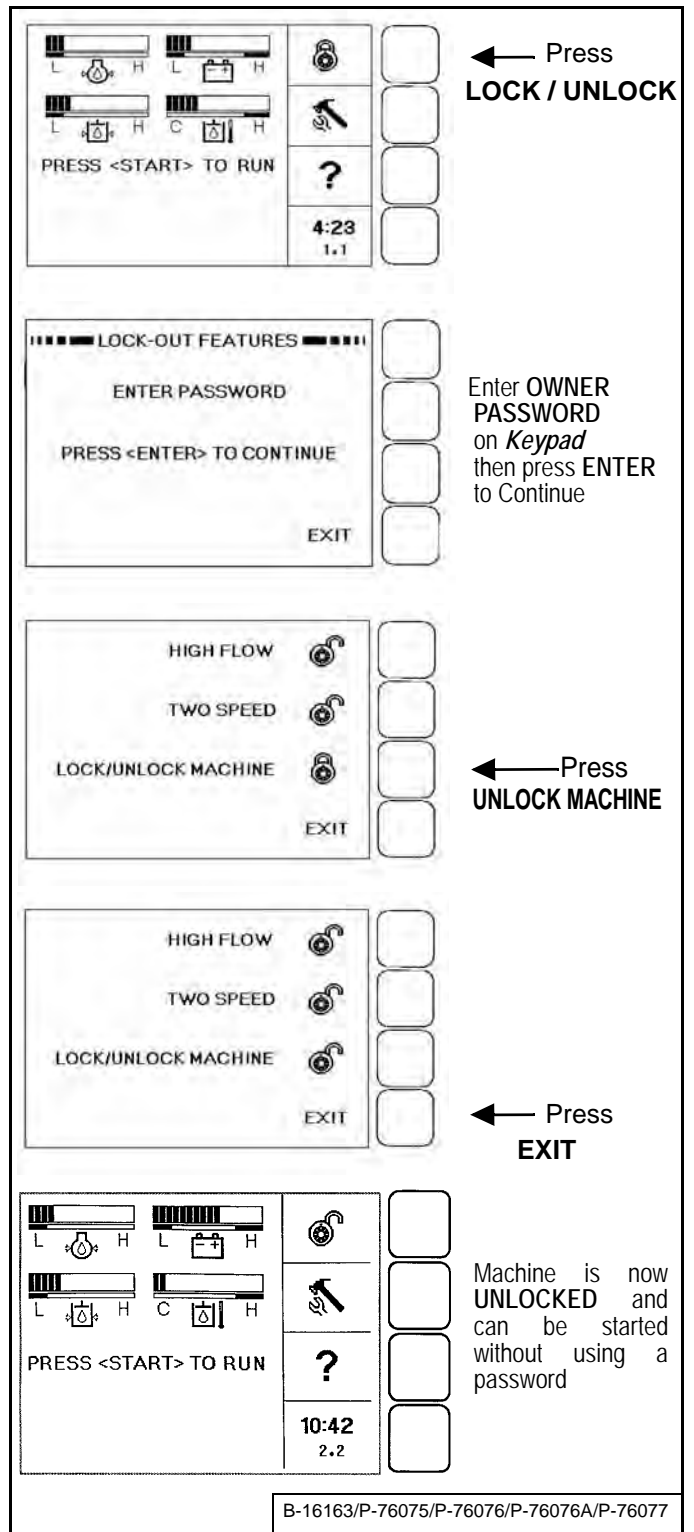

MACHINE SIGN TRANSLATIONS (CONT'D)

Warning (6718706)

**WARNING**



Unexpected loader, lift arm or attachment movement caused by cab contact with steering levers can cause serious injury or death.

BEFORE RAISING OR LOWERING CAB:

- Stop engine

70485 SW 6718706B enUS

**ADVERTÊNCIA**



El movimiento inesperado del cargador, brazo de elevación o implemento causado por el contacto de la cabina con las palancas de direccionamiento puede causar lesiones serias o accidentes fatales.

ANTES DE LEVANTAR O BAJAR LA CABINA:

- Apague el motor

70485 SW 6718706B enUS

**AVERTISSEMENT**



Un mouvement intempestif de la chargeuse, du bras de levage ou de l'accessoire dû au contact de la cabine avec les leviers de direction peut entraîner des blessures graves, voire mortelles.

AVANT DE RELEVER OU D'ABAISSER LA CABINE :

- Arrêtez le moteur

70485 SW 6718706B enUS

Warning (6710358)

**WARNING**



AVOID INJURY OR DEATH

- Never carry riders.
- Never use loader as a man lift or work platform.

62702 SW 6710358B enUS

**ADVERTENCIA**



EVITE LESIONES O LA MUERTE

- Nunca lleve ocupantes.
- Nunca utilice la cargadora para levantar personas o como plataforma de trabajo.

62702 SW 6710358B enAR

**AVERTISSEMENT**



RISQUE DE BLESSURE OU DE MORT

- Ne transportez jamais de passagers.
- N'utilisez jamais la chargeuse comme élévateur pour le personnel ou comme plateforme de travail.

62702 SW 6710358B frCA

Danger (6809511)

**DANGER**

AVOID DEATH

- Disconnecting hydraulic lines can cause the lift arms or attachment to drop.
- Always use an approved lift arm support when lift arms are in a raised position.



70485 SW 6809511C enUS

**DANGER**

70485 SW 6809511C enUS

**DANGER**

AVOID DEATH

- Disconnecting hydraulic lines can cause the lift arms or attachment to drop.
- Always use an approved lift arm support when lift arms are in a raised position.



70485 SW 6809511C enUS

**PELIGRO**

EVITE LESIONES FATALES

- Desconectar las líneas hidráulicas puede provocar que los brazos de elevación o el implemento se caigan.
- Utilice siempre un soporte aprobado cuando los brazos de elevación están levantados.



62245 SW 05 6809511 AR

**PELIGRO**

70485 SW 6809511C enUS

**PELIGRO**

EVITE LESIONES FATALES

- Desconectar las líneas hidráulicas puede provocar que los brazos de elevación o el implemento se caigan.
- Utilice siempre un soporte aprobado cuando los brazos de elevación están levantados.



62245 SW 05 6809511 AR

**DANGER**

DANGER DE MORT

- Le débranchement des conduites hydrauliques peut provoquer la chute des bras de levage ou de l'accessoire.
- Utilisez toujours un arrêt de bras de levage approuvé quand les bras de levage sont relevés.



70485 SW 6809511C enUS

**DANGER**

70485 SW 6809511C enUS

**DANGER**

DANGER DE MORT

- Le débranchement des conduites hydrauliques peut provoquer la chute des bras de levage ou de l'accessoire.
- Utilisez toujours un arrêt de bras de levage approuvé quand les bras de levage sont relevés.



70485 SW 6809511C enUS

## SPECIFICATIONS

(S175) LOADER SPECIFICATIONS .....	181
Machine Dimensions .....	181
Performance .....	182
Engine .....	182
Drive System .....	182
Controls .....	183
Hydraulic System .....	183
Electrical .....	184
Capacities .....	184
Tires .....	184

CLICK HERE TO **DOWNLOAD** THE COMPLETE MANUAL

- Thank you very much for reading the preview of the manual.
- You can download the complete manual from: [www.heydownloads.com](http://www.heydownloads.com) by clicking the link below



- Please note: If there is no response to CLICKING the link, please download this PDF first and then click on it.

CLICK HERE TO **DOWNLOAD** THE COMPLETE MANUAL