



Bobcat®

Operation & Maintenance Manual

S150 Skid-Steer Loader

S/N 529711001 & Above
S/N 529811001 & Above
S/N A8M011001 - A8M059999
S/N AC3011001 - AC3059999

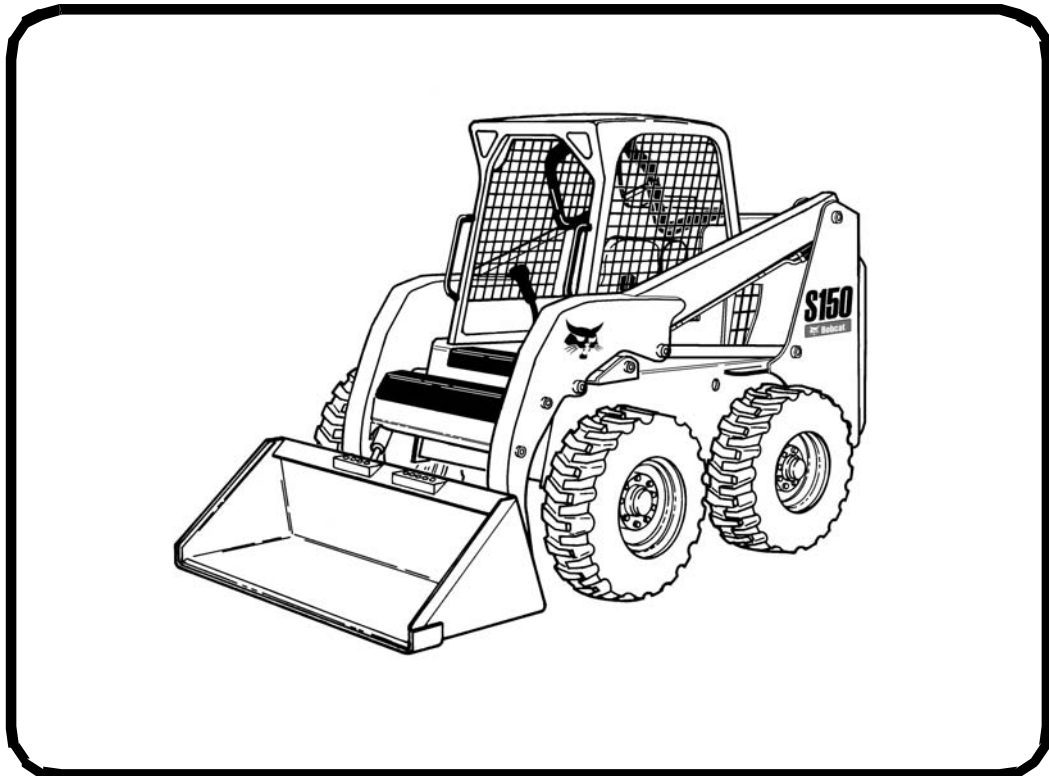

**EQUIPPED WITH
BOBCAT INTERLOCK
CONTROL SYSTEM (BICS)**



CLICK HERE TO **DOWNLOAD** THE COMPLETE MANUAL

- Thank you very much for reading the preview of the manual.
- You can download the complete manual from: www.heydownloads.com by clicking the link below



- Please note: If there is no response to CLICKING the link, please download this PDF first and then click on it.

CLICK HERE TO **DOWNLOAD** THE COMPLETE MANUAL

LOADER IDENTIFICATION

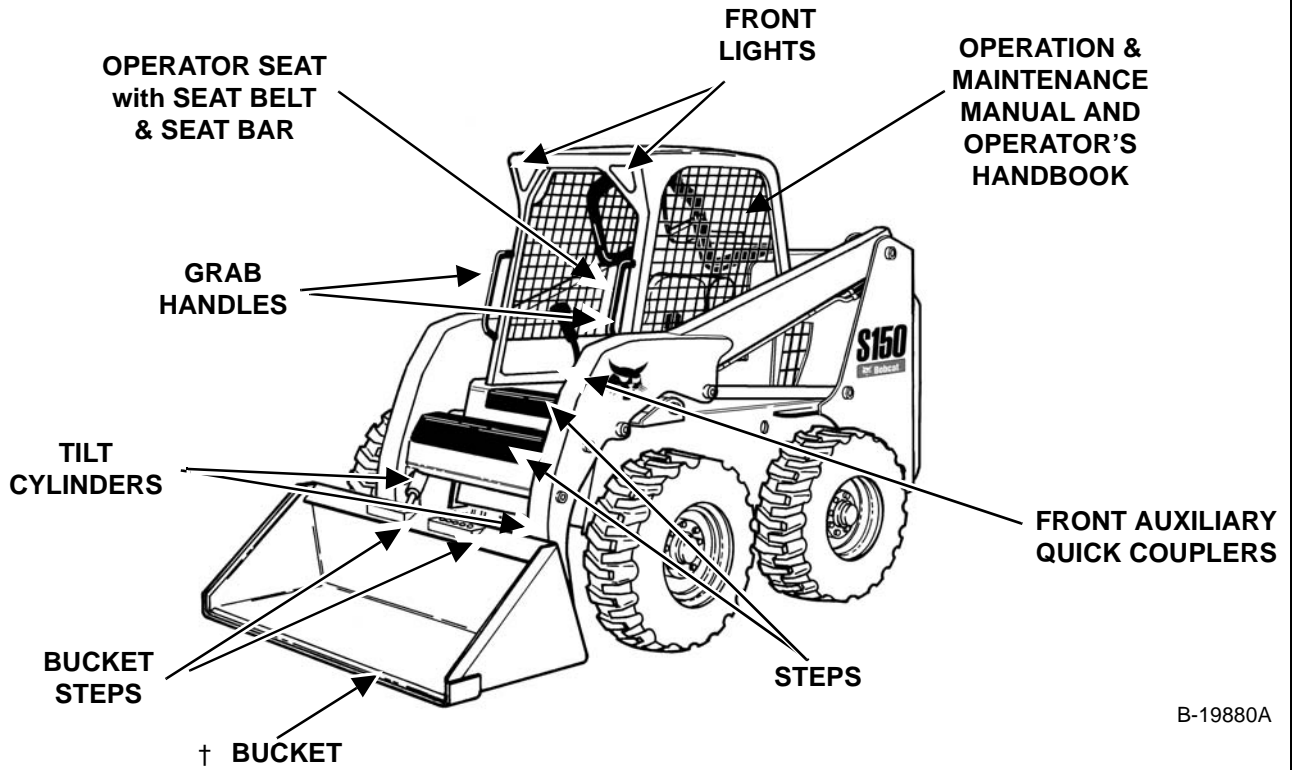

B-19880A

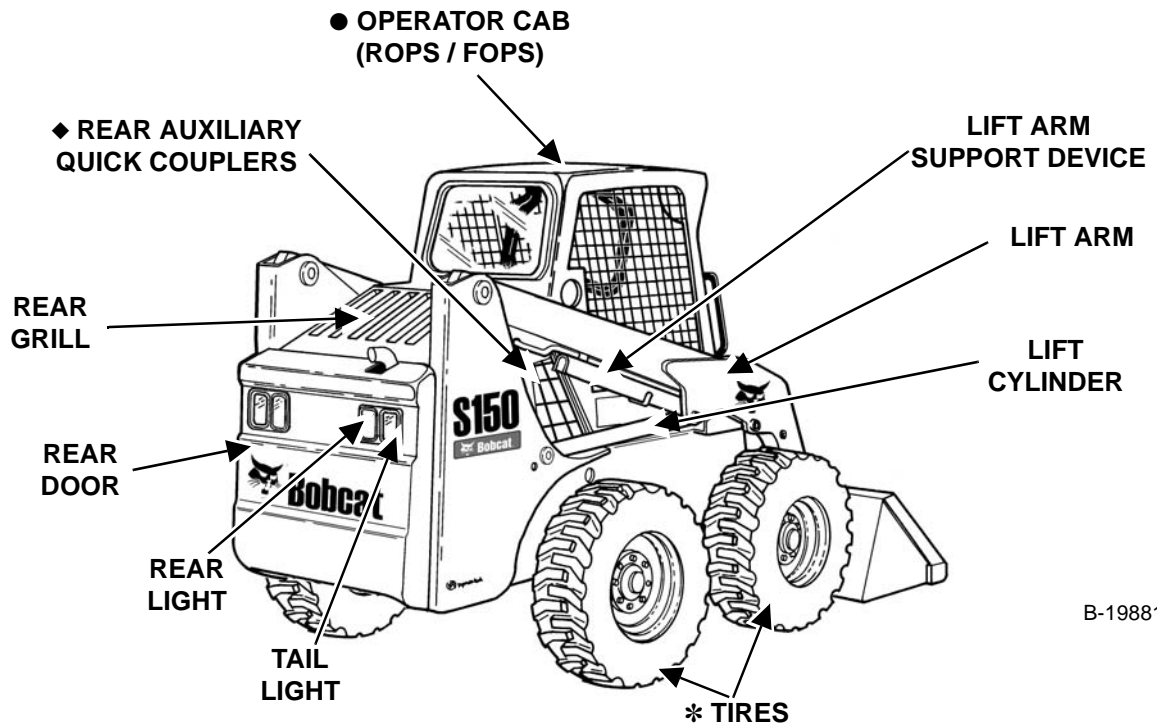

B-19881A

◆ Optional or Field Accessory (Not Standard Equipment)

* TIRES - Tires shown may not be standard. The machine is factory equipped with standard tires. Other tires are available.

† Bucket - Several different buckets and other attachments are available for this machine.

● ROPS, FOPS - Roll Over Protective Structure, per ISO 3471, and Falling Object Protective Structure per ISO 3449, Level I. Level II is available.



Bobcat®

INSTRUMENT PANEL IDENTIFICATION (CONT'D)

Right Panel (Keyless)

Figure OI-3

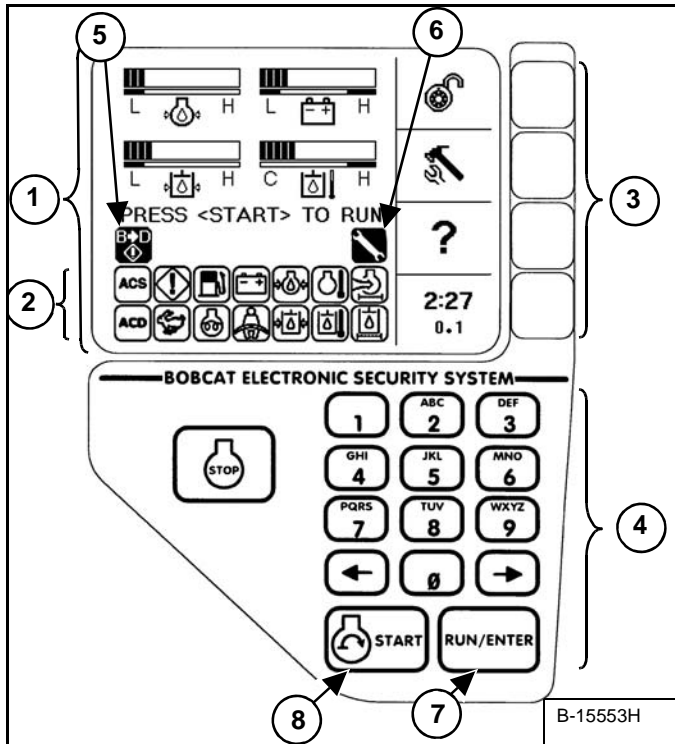

The right instrument panel shown [Figure OI-3] is the Keyless Panel.

1. **Display Screen:** The Display Screen is where all system setup, monitoring, troubleshooting, and error conditions are displayed.
2. **Function Icons:** The lower left area of the Display Screen contains the same icons as the Key Switch Panel. These icons are only visible when the monitoring system has detected the associated condition.
3. **Selection Buttons:** The four Selection Buttons allow you to select items from the Display Screen and scroll through screens.
4. **Keypad:** The numeric keypad has two functions:
 - To enter a number code (password) to allow starting the engine (Keyless Start).
 - To enter a number as directed for further use of the Display Screen.
5. **Bobcat Controller / Display Icon:** Indicates communication error between Bobcat controller and instrument panel. (See DIAGNOSTIC SERVICE CODES on Page SA-4.)
6. **BobCARE PMSM Icon:** Indicates planned maintenance is due. (See MAINTENANCE CLOCK on Page SA-14.)

Figure OI-4

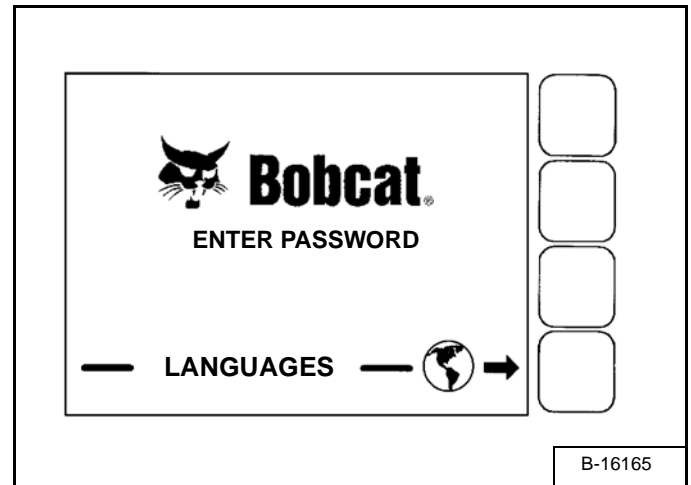

The first screen you will see on your new loader will be as shown in [Figure OI-4].

When this screen is on the display you can enter the password and start the engine or change the Display Panel setup features.

NOTE: Your new loader (with Keyless Instrument Panel) will have a Owner Password. Your dealer will provide you with this password. Change the password to one that you will easily remember to prevent unauthorized use of your loader. (See Changing The Owner Password on Page SA-12.) Keep your password in a safe place for future needs.

Start Engine: Use the Keypad to enter the numbers (letters) of your password and press the RUN / ENTER key (Item 5) [Figure OI-3].

Press and hold the START button (Item 6) [Figure OI-3] until the engine starts.

Change Language: Press the Selection button at the end of the arrow [Figure OI-4] to go to the next screen.

TWO-SPEED CONTROL

This machine may be equipped with Two-Speed.

Description

The two-speed allows you to reduce cycle times when there is a long travel distance between the dig site and the dump site. You can also use the two-speed when traveling from one job site to another at faster speeds.



Figure OI-27

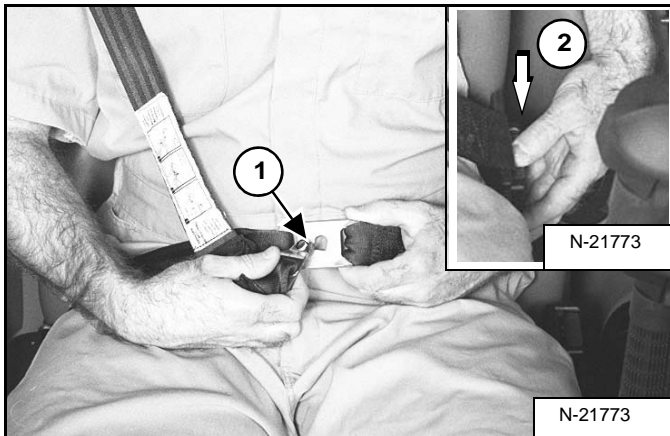

NOTE: The 3-point restraint must be used when selecting two-speed operation [Figure OI-27].

Connect the shoulder belt to the lap belt (Item 1). Pull the lap belt across to the left side of the seat (Item 2) [Figure OI-27] and fasten.

The shoulder belt must be positioned over your right shoulder and lap belt over your lower hips [Figure OI-27].

NOTE: The two-speed icon (Item 2) [Figure OI-28] or [Figure OI-29] will flash slowly if you attempt to engage two-speed operation before the hydraulic / hydrostatic fluid has been warmed up. (See Warming The Hydraulic / Hydrostatic System on Page OI-38.)

Operation

Standard and ACS (If Equipped)

Figure OI-28

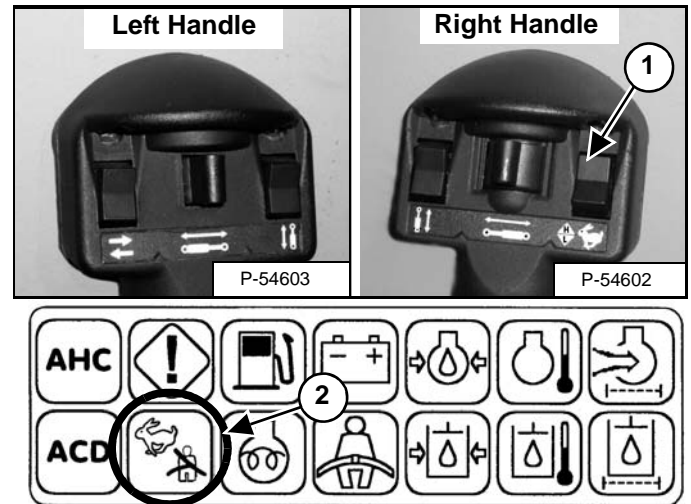

Press the top of the switch (Item 1) on the right handle for high range. The two-speed icon located on the right hand instrument panel (Item 2) [Figure OI-28] will come on.

NOTE: This toggle switch retains the selected range. The loader will be in high range speed at start-up if the switch is in the high range position.

Press the bottom of the switch for low range.

SJC (If Equipped)

Figure OI-29

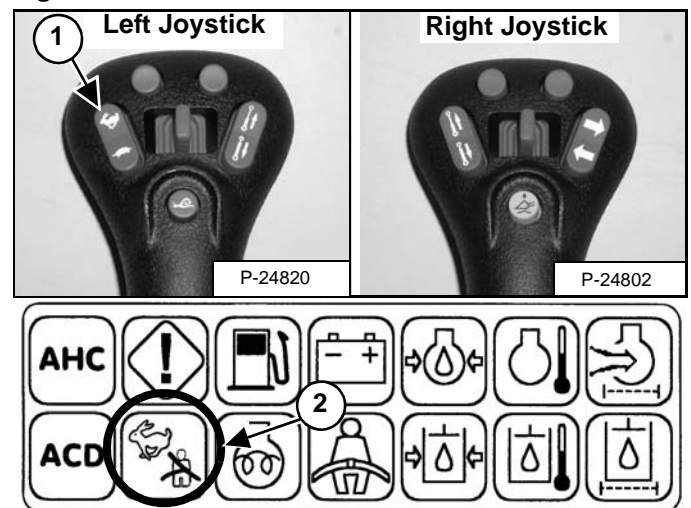

Press the top of the switch (Item 1) on the left joystick for high range. The two-speed icon located on the right hand instrument panel (Item 2) [Figure OI-29] will come on.

NOTE: This momentary contact switch does not retain the last range selected. The loader will default to low range speed at start-up.

Press the bottom of the switch for low range.

HYDRAULIC CONTROLS (CONT'D)

Secondary Front Auxiliary Hydraulics

This machine may be equipped with Secondary Front Auxiliary Hydraulics.

Figure OI-52

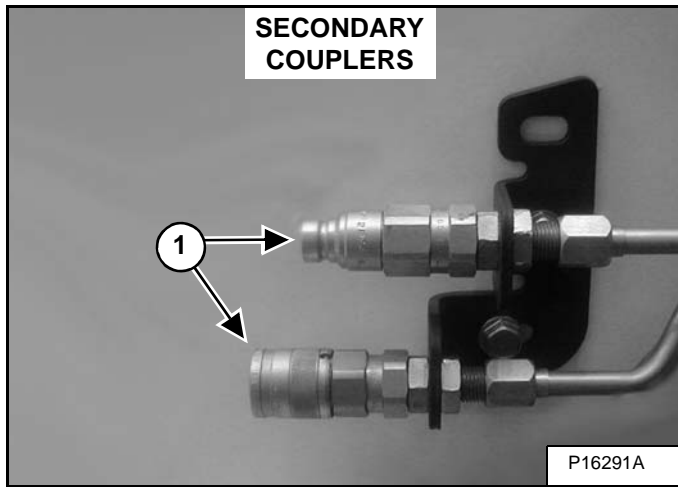

The secondary front auxiliary quick couplers (Item 1) [Figure OI-52] are available as a Field Installed Accessory. These are used when there is a need for additional auxiliary hydraulics. (EXAMPLE: Side shift on the Planer.)

Connect the attachment to the secondary front auxiliary hydraulics (Item 1) [Figure OI-52].

Figure OI-53

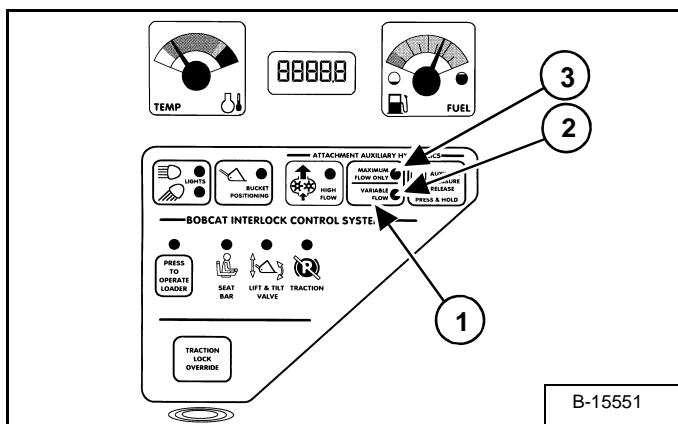

Set the Auxiliary Hydraulics button for *Variable Flow* or *Maximum Flow Only*.

Press the auxiliary hydraulics button (Item 1) [Figure OI-53] once for *VARIABLE FLOW* or twice for *MAXIMUM FLOW ONLY*.

Standard and ACS (If Equipped)

Figure OI-54

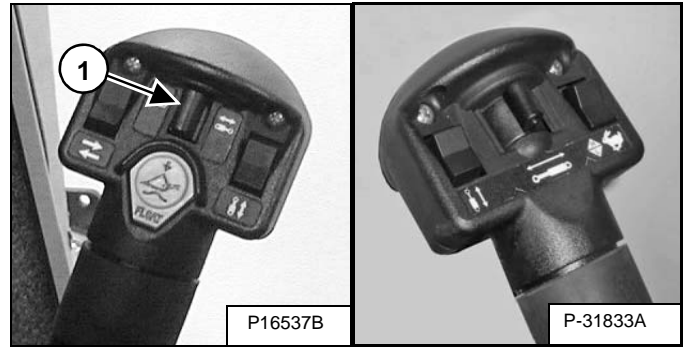

SJC (If Equipped)

Figure OI-55

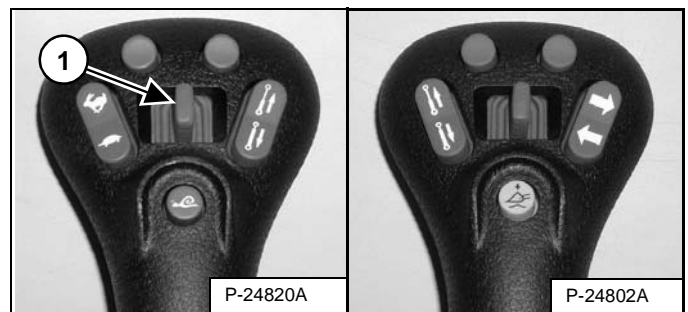

Push switch (Item 1) [Figure OI-54] or [Figure OI-55] to the right or left to change fluid flow direction. (EXAMPLE: Side shift on the Planer.)

NOTE: The secondary front auxiliary hydraulics and the rear auxiliary hydraulics operate from the same auxiliary section of the control valve. To operate an attachment with secondary front auxiliary hydraulics, you must disconnect any attachment connected to the rear auxiliary hydraulic quick couplers.

To disengage, press the auxiliary hydraulics button (Item 1) until both lights (Items 2 & 3) [Figure OI-53] are off.

NOTE: When the operator is seated and raises the seat bar, the Auxiliary Hydraulic System (Front and Rear) will deactivate.

STARTING THE ENGINE (CONT'D)

Keyless (Cont'd)

Figure OI-74

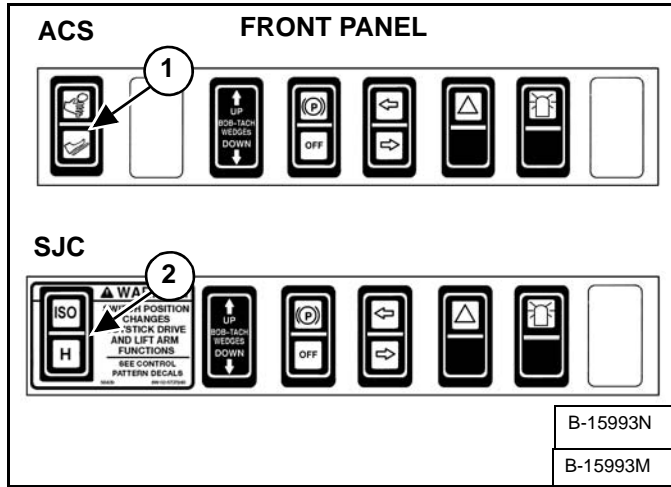

(ACS) Select hand control or foot pedal operation (Item 1) [Figure OI-74].

OR

(SJC) Select 'ISO' or 'H' Control Pattern (Item 2) [Figure OI-74].

Figure OI-75

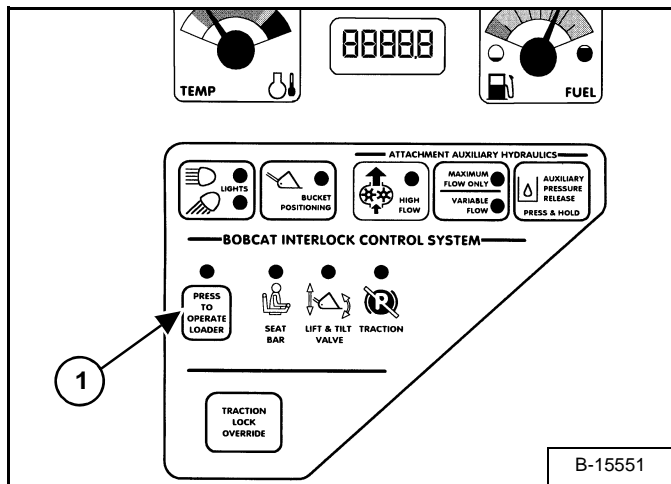

Press the PRESS TO OPERATE LOADER button (Item 1) [Figure OI-75] to activate the BICS system and to perform hydraulic and loader functions. (See Cold Temperature Starting on Page OI-37.)

NOTE: (SJC) The pending mode will flash which will indicate PRESS TO OPERATE LOADER is required. The light will flash when key is ON and continue to flash until the PRESS TO OPERATE LOADER button is pressed and thereafter it will light solid. If the mode (ISO/H) is changed while driving, the active mode will be solid and the pending mode will flash. When operation of the machine is returned to neutral, the active mode will then turn off and the pending mode will continue to flash until the PRESS TO OPERATE LOADER button is pressed.

! WARNING

AVOID INJURY OR DEATH

When an engine is running in an enclosed area, fresh air must be added to avoid concentration of exhaust fumes. If the engine is stationary, vent the exhaust outside. Exhaust fumes contain odorless, invisible gases which can kill without warning.

W-2050-0807

Cold Temperature Starting

! WARNING

AVOID INJURY OR DEATH

Do not use ether with glow plug (preheat) systems. Explosion can result which can cause injury, death, or severe engine damage.

W-2071-0907

If the temperature is below freezing, perform the following to make starting the engine easier:

- Replace the engine oil with the correct type and viscosity for the anticipated starting temperature. (See ENGINE LUBRICATION SYSTEM on Page PM-25.)
- Make sure the battery is fully charged.
- Install an engine heater, available from your Bobcat Loader dealer.
- Move engine speed control lever halfway before starting. Return to idle position after the engine starts.

NOTE: The LCD of the *Keyless Panel* may not be immediately visible when the temperature is below -15°F (-26°C). It may take 30 seconds to several minutes for the Display Panel to warm up. All systems remain monitored even when the display is off.

ATTACHMENTS (CONT'D)

Installing And Removing The Attachment (Power Bob-Tach) (Cont'd)

Removing

Lower the lift arms and put the attachment flat on the ground and lower or close the hydraulic equipment.

- If the attachment is hydraulically controlled (combination bucket, backhoe, etc.):

Stop the engine and relieve hydraulic pressure in the auxiliary circuit. (See Relieve Hydraulic Pressure (Loader and Attachment) on Page OI-26.)

Exit the loader and disconnect the hydraulic hoses from the attachment.

Enter the loader.

Perform the PRE-STARTING PROCEDURE. (See PRE-STARTING PROCEDURES on Page OI-31.)

Start the engine.

Release the parking brake.

Figure OI-101

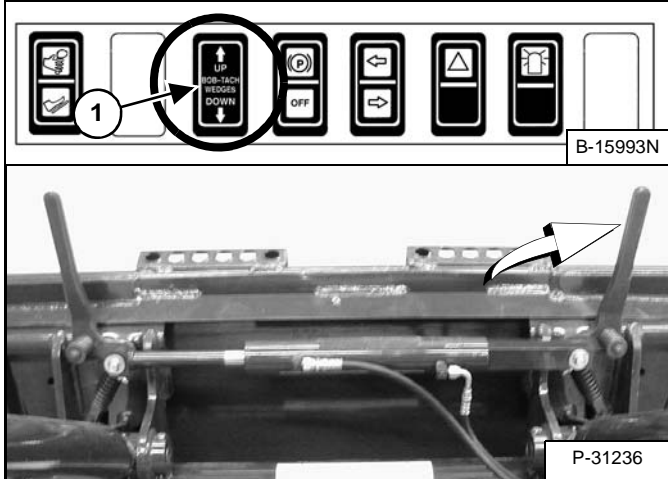

Push and hold the BOB-TACH “WEDGES UP” switch (Front Panel) (Item 1) [Figure OI-101] until the wedges are fully raised.

Tilt the Bob-Tach forward.

Figure OI-102

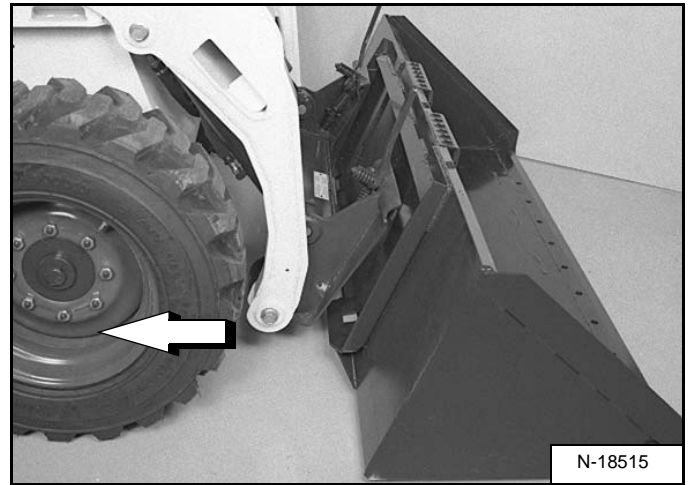

Move the loader backward, away from the bucket or attachment [Figure OI-102].

NOTE: The Power Bob-Tach system has continuous pressurized hydraulic oil to keep the wedges in the engaged position and prevent attachment disengagement. Because the wedges can slowly lower, the operator may need to reactivate the switch (WEDGES UP) when removing an attachment to be sure both wedges are fully raised.

CLICK HERE TO **DOWNLOAD** THE COMPLETE MANUAL

- Thank you very much for reading the preview of the manual.
- You can download the complete manual from: www.heydownloads.com by clicking the link below



- Please note: If there is no response to CLICKING the link, please download this PDF first and then click on it.

CLICK HERE TO **DOWNLOAD** THE COMPLETE MANUAL

TOWING THE LOADER

Procedure

Because of the design of the loader, there is not a recommended towing procedure.

- The loader can be lifted onto a transport vehicle.
- The loader can be skidded a short distance to move for service (EXAMPLE: Move onto a transport vehicle.) without damage to the hydrostatic system. (The tires/tracks will not turn.) There might be slight wear to the tires/tracks when the loader is skidded.

The towing chain (or cable) must be rated at 1 & 1/2 times the weight of the loader (See Performance on Page SPEC-4.)

SERVICE SCHEDULE

Chart

Maintenance work must be done at regular intervals. Failure to do so will result in excessive wear and early failures. The service schedule is a guide for correct maintenance of the Bobcat Loader.



WARNING

Instructions are necessary before operating or servicing machine. Read and understand the Operation & Maintenance Manual, Operator's Handbook and signs (decals) on machine. Follow warnings and instructions in the manuals when making repairs, adjustments or servicing. Check for correct function after adjustments, repairs or service. Untrained operators and failure to follow instructions can cause injury or death.

W-2003-0903

SERVICE SCHEDULE		HOURS					
ITEM	SERVICE REQUIRED	8-10	50	100	■ 250	■ 500	■ 1000
Engine Oil	Check the oil level and add as needed. Do not overfill.						
Engine Air Filter and Air System	Check display panel. Service only when required. Check for leaks and damaged components.						
Engine Cooling System	Clean debris from oil cooler, radiator and grill. Check coolant level COLD and add premixed coolant as needed.						
Fuel Filter	Remove the trapped water.						
Lift Arms, Cylinders, Bob-Tach Pivot Pins and Wedges	Lubricate with multi-purpose lithium based grease.						
Tires	Check for damaged tires and correct air pressure. Inflate to MAXIMUM pressure shown on the sidewall of the tire.						
Seat Bar, Control Interlocks, Seat Belt, Seat Belt Retractors	Check the condition of seat belt. Clean or replace seat belt retractors as needed. Check the seat bar and control interlocks for correct operation. Clean dirt and debris from moving parts.						
Bobcat Interlock Control Systems (BICS)	Check for correct function. Lift and Tilt functions MUST NOT operate with seat bar raised. See details in this Manual.						
Safety Signs and Safety Treads	Check for damaged signs (decals) and safety treads. Replace any signs or safety treads that are damaged or worn.						
Operator Cab	Check the fastening bolts, washers and nuts. Check the condition of the cab.						
Indicators and Lights	Check for correct operation of all indicators and lights.						
Heater and A/C Filters (If Equipped)	Clean or replace filters as needed.						
Hydraulic Fluid, Hoses and Tubelines	Check fluid level and add as needed. Check for damage and leaks. Repair or replace as needed.						
Final Drive Trans. (Chaincase),	Check fluid level and add as needed.						
Parking Brake, Foot Pedals, Hand Controls and Steering Levers or Joysticks	Check for correct operation. Repair or adjust as needed.						
Wheel Nuts	Check for loose wheel nuts and tighten to correct torque. (See TIRE MAINTENANCE in this manual.)	□					
Spark Arrestor Muffler	Clean the spark chamber.						
Battery	Check cables, connections and electrolyte level. Add distilled water as needed.						
Steering Lever Pivots	Grease fittings.						
Fuel Filter	Replace filter element.						
Engine / Hydro. Drive Belt	Check for wear or damage. Check idler arm stop.		▲				
Drive Belts (Alternator, air conditioner, water pump)	Check condition and tension. Adjust or replace as needed.						
Bobcat Interlock Control System (BICS)	Check the function of the lift arm bypass control.						
Hydraulic / Hydrostatic Filter, Charge Filter, Reservoir Breather	Replace the hydraulic / hydrostatic filter, charge filter, and the reservoir breather.		●				
Engine Oil and Filter	Replace oil and filter.		▲		*		
Final Drive Trans. (Chaincase)	Replace the fluid.						
Hydraulic Reservoir	Replace the fluid.						
Case Drain Filters	Replace the filters.		▲				
Engine Valves	Adjust the engine valves.						○
Coolant	Replace the coolant						Every 2 years

■ Or every 12 months.

▲ Perform at first 50 hours, then as scheduled.

□ Check every 8 - 10 hours for the first 24 hours, then at 50 hour intervals.

● Replace the hydraulic / hydrostatic filter element after the first 50 hours, then when the transmission warning light comes ON while operating or as scheduled.

* Change oil and filter every 250 hours when operating under severe conditions.

○ Perform at first 500 hours, then as scheduled.

REAR DOOR

Opening And Closing

! WARNING

AVOID INJURY OR DEATH

Never service or adjust the machine when the engine is running unless instructed to do so in the manual.

W-2012-0497

Figure PM-18

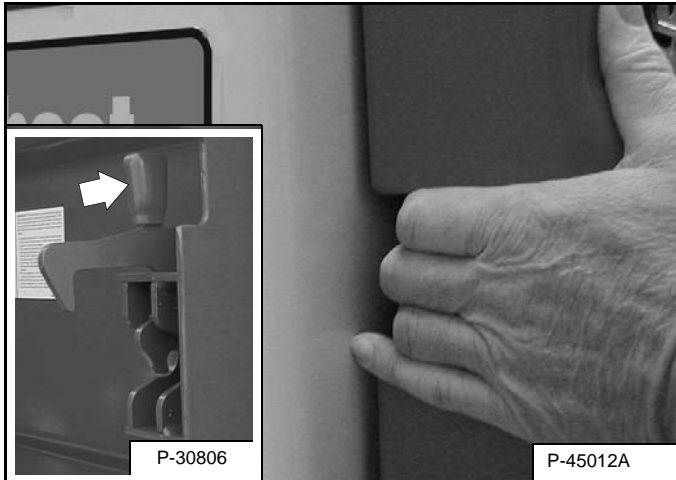

Reach into the slot in the rear door and pull the latch handle [Figure PM-18].

Pull the rear door open.

Figure PM-19

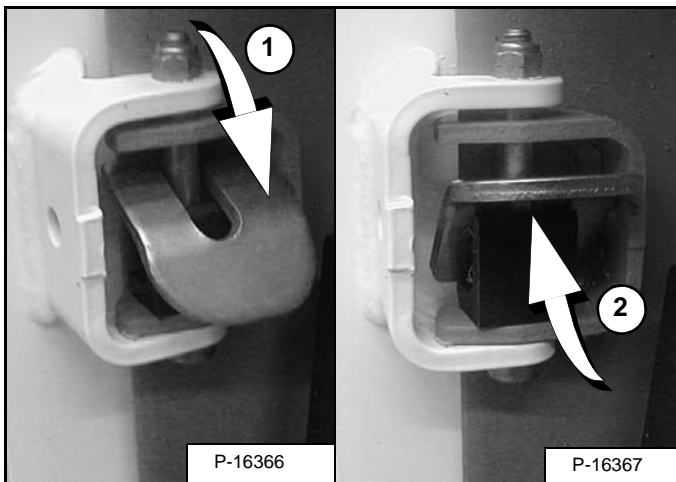

Move the door stop into the engaged position (Item 1) [Figure PM-19] to hold the door open.

Move the door stop up (Item 2) [Figure PM-19] to disengage the door stop and allow the door to close.

Close the door.

! WARNING

Keep the rear door closed when operating the machine. Failure to do so could seriously injure a bystander.

W-2020-1285

Adjusting

Figure PM-20

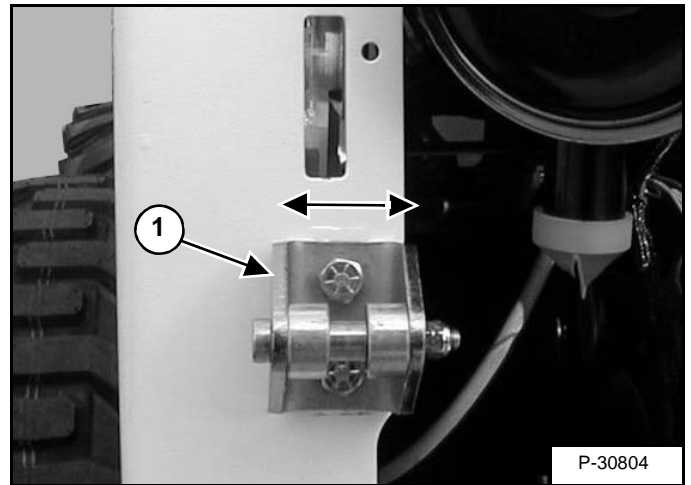

The door latch (Item 1) [Figure PM-20] can be adjusted side to side for alignment with the door latch mechanism.

Close the rear door before operating the loader.

ENGINE COOLING SYSTEM (CONT'D)

Removing And Replacing Coolant

Open the rear door and remove the rear grill.

Figure PM-41

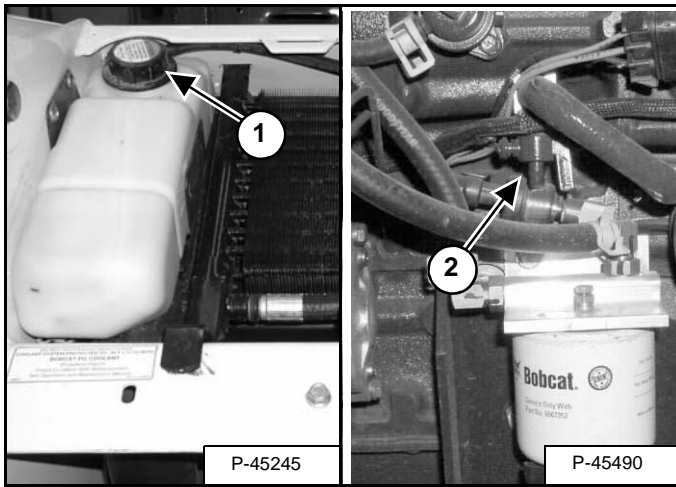

Remove the coolant fill cap (Item 1) [Figure PM-41].

Connect a hose to the engine block drain valve (Item 2) [Figure PM-41]. Open the drain valve and drain the coolant into a container. Close the drain valve.

Recycle or dispose of used coolant in an environmentally safe manner.

NOTE: The loader is factory filled with propylene glycol coolant (purple color). DO NOT mix propylene glycol with ethylene glycol.

Premix coolant (53% propylene glycol and 47% water) in a separate container. For correct capacity, (See Capacities on Page SPEC-6.)

One gallon and one pint of propylene glycol mixed with one gallon of water is the correct ratio (53% / 47%) to provide -34°F (-37°C) freeze protection.

Fill the tank until it is at the lower marker on the tank.

Use a refractometer to check the condition of propylene glycol in the cooling system and replace the coolant fill cap.

NOTE: When installing the coolant fill cap, the cap must be tightened until it clicks.

Run the engine until it is at operating temperature. Stop the engine. Check the coolant level in the recovery tank when cool. Add coolant as needed.

Install the rear grill and close the rear door.

HYDRAULIC / HYDROSTATIC SYSTEM (CONT'D)

Breather Cap

See the SERVICE SCHEDULE for the correct replacement interval. (See SERVICE SCHEDULE on Page PM-7.)

Raise the cab. (See Raising on Page PM-14.)

Figure PM-63

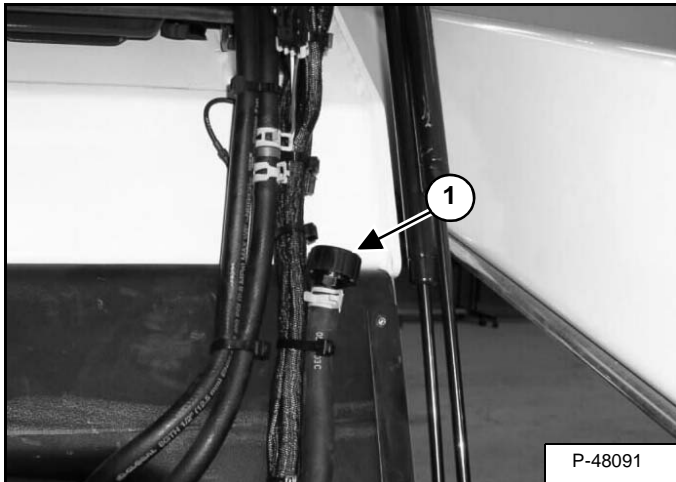

Remove and discard the hydraulic breather cap (Item 1) **[Figure PM-63]**.

Install new breather cap.

Lower the cab. (See Lowering on Page PM-15.)

BOB-TACH (POWER)

This machine may be equipped with a Power Bob-Tach.

Inspection And Maintenance

Figure PM-84

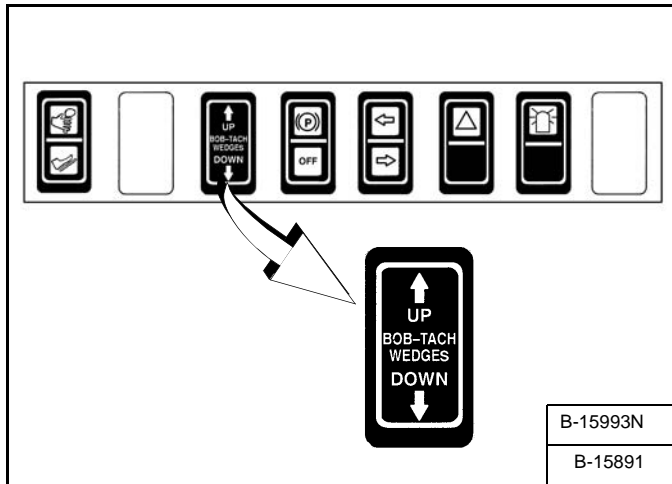

Push and hold the BOB-TACH “WEDGES UP” switch [Figure PM-84] until wedges are fully raised. Push and hold the BOB-TACH “WEDGES DOWN” switch [Figure PM-84] until the wedges are fully down.

The levers and wedges must move freely.



Bob-Tach wedges must extend through the holes in attachment. Lever(s) must be fully down and locked. Failure to secure wedges can allow attachment to come off and cause injury or death.

W-2102-0497

Figure PM-85

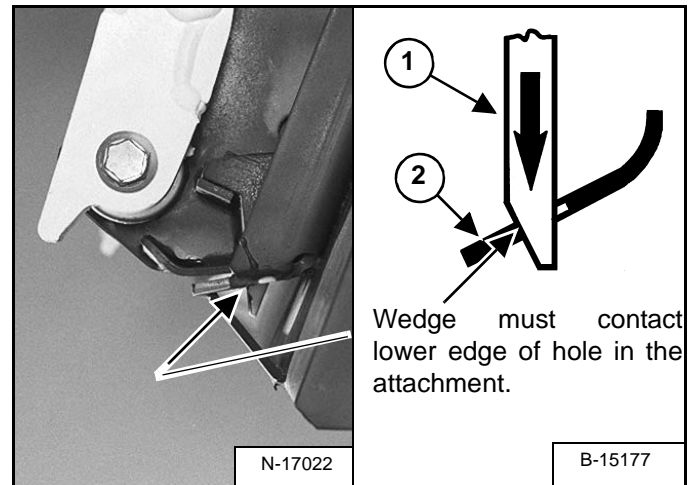

The wedges must extend through the holes in the attachment mounting frame (Item 1) [Figure PM-85].

The spring loaded wedge (Item 1) [Figure PM-85] must contact the lower edge of the hole in the attachment (Item 2) [Figure PM-85].

If the wedge does not contact the lower edge of the hole [Figure PM-85], the attachment will be loose and can come off the Bob-Tach.

Figure PM-86

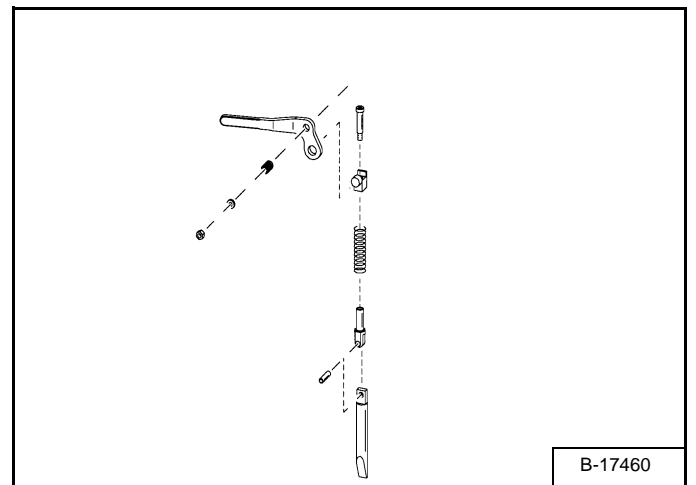

Inspect the mounting frame on the attachment and the Bob-Tach, linkages and wedges for excessive wear or damage [Figure PM-86]. Replace any parts that are damaged, bent, or missing. Keep all fasteners tight.

Look for cracked welds. Contact your Bobcat dealer for repair or replacement parts.

Lubricate the wedges. (See SERVICE SCHEDULE on Page PM-7.) (See LUBRICATING THE LOADER on Page PM-43.)

DIAGNOSTIC SERVICE CODES (CONT'D)

Service Codes List (Cont'd)

CODE		CODE	
75-68	Angle sensors not calibrated	80-03	ACD output 'A' error OFF
75-69	Battery voltage out of range high		
75-70	Interrupted power (Also occurs after software updates)	81-02	ACD output 'B' error ON
75-71	Battery voltage out of range low	81-03	ACD output 'B' error OFF
75-72	Drive pump not calibrated		
75-73	ISO/H pattern switch flipped while operating	82-02	ACD output 'C' error ON
75-74	Right wheel speed uncommanded motion	82-03	ACD output 'C' error OFF
75-75	Left wheel speed uncommanded motion		
75-76	No communication from ACS controller	83-02	ACD output 'D' error ON
75-77	Left speed sensor out of range high	83-03	ACD output 'D' error OFF
75-78	Right speed sensor out of range high		
75-79	Left speed sensor out of range low	84-02	ACD output 'E' error ON
75-80	Right speed sensor out of range low	84-03	ACD output 'E' error OFF
75-81	Right front steer retract short to battery		
75-82	Left front steer retract short to battery	85-02	ACD output 'F' error ON
75-83	Right rear steer retract short to battery	85-03	ACD output 'F' error OFF
75-84	Left rear steer retract short to battery		
75-85	5 volt sensor supply 1 out of range high	86-02	ACD output 'G' error ON
75-86	Sensor supply 2 out of range high	86-03	ACD output 'G' error OFF
75-88	Controller in programming mode		
75-91	Left swash plate sensor reversed	87-02	ACD output 'H' error ON
75-92	Right swash plate sensor reversed	87-03	ACD output 'H' error OFF
75-93	Unresponsive right speed sensor		
75-94	Unresponsive left speed sensor	90-02	Service tool output 'C' error ON
75-95	Left speed sensor reverse direction	90-03	Service tool output 'C' error OFF
75-96	Right speed sensor reverse direction		
75-98	Controller in calibration mode	91-02	Service tool output 'D' error ON
		91-03	Service tool output 'D' error OFF
76-73	Left hand panel system RX error		
		92-02	Service tool output 'E' error ON
77-48	Key switch multiple	92-03	Service tool output 'E' error OFF
78-74	Door/transport lock open/active	93-02	Service tool output 'F' error ON
		93-03	Service tool output 'F' error OFF
80-02	ACD output 'A' error ON		

AVERTISSEMENT

RISQUE DE BLESSURES GRAVES, VOIRE MORTELLES

- Maintenez la porte fermée, sauf pour les entretiens.
- Débarrassez le moteur de tous matériaux inflammables.
- Maintenez le corps, les objets et les vêtements à l'écart des contacts électriques, des pièces mobiles, des parties brillantes et de l'échappement.
- N'utilisez pas la chargeuse dans un environnement chargé de gaz ou de poussières explosifs, ou dans lequel l'échappement risque d'entrer en contact avec des matériaux inflammables.
- N'utilisez jamais de l'éther ou du liquide d'aide au démarrage avec un moteur diesel utilisant des bougies de préchauffage. Employez uniquement des aides au démarrage approuvées par le fabricant du moteur.
- En cas de fuite, les liquides sous pression peuvent traverser la peau et entraîner des blessures graves.
- L'acide des batteries cause de graves brûlures. Portez des lunettes de sécurité. Si l'acide entre en contact avec les yeux, la peau ou les vêtements, rincez abondamment avec de l'eau. En cas de contact avec les yeux, rincez abondamment et consultez un médecin.
- Les batteries dégagent des gaz inflammables et explosifs. N'approchez pas la batterie avec des sources d'arc, des étincelles, des flammes ou des cigarettes allumées.
- En cas de démarrage à l'aide d'une batterie d'appoint, branchez le câble négatif au moteur de la chargeuse en dernier lieu (jamais à la batterie). Dès que le moteur tourne, débranchez d'abord le câble négatif du moteur.
- Les gaz d'échappement peuvent être mortels. Travaillez toujours en atmosphère correctement ventilée.

TABLEAU D'ENTRETIEN

- ▲▲ TOUTES LES 10 HEURES (AVANT DE DEMARRER LA CHARGEUSE)
 - HUILE MOTEUR - Vérifiez le niveau d'huile et faites éventuellement l'appoint, sans excès. Remplacez l'huile et le filtre après les premières 50 heures, consultez ensuite votre Manuel de l'Opérateur et d'Entretien pour les intervalles.
 - FILTRE À AIR MOTEUR - Contrôlez le témoin d'état. Effectuez l'entretien si nécessaire. N'utilisez pas d'air comprimé pour nettoyer les éléments.
 - VENTILATEUR DU MOTEUR - Contrôlez l'étanchéité du système et l'état des composants.
 - CIRCUIT DU REFOUILLAGE DU MOTEUR - Éliminez les débris du refroidisseur d'huile et des grilles. Vérifiez le niveau de réfrigérant à froid ; faites éventuellement l'appoint avec un mélange.
 - FILTRE D'ALIMENTATION - Vidangez l'eau de condensation.
 - AXES PIVOT ET CALES DU BOB-TACH, VERINS, ARTICULATIONS ET BRAS DE LEVAGE, VERINS DE DIRECTION (machines AWS seulement). Lubrifiez avec une graisse tous usages à base de lithium.
 - CEINTURE DE SÉCURITÉ, ARCEAU DE SIÈGE ET VERROUILLAGE DES COMMANDES
 - Vérifiez le bon fonctionnement. Éliminez les débris et saletés des pièces mobiles. Réparez et remplacez le cas échéant.
 - BICS - Vérifiez le fonctionnement correct. Éliminez les débris et saletés des pièces mobiles. Les commandes de levage et de cavage NE DOIVENT PAS fonctionner avec l'arceau de siège relevé.
 - PNEUS - Vérifiez la pression de gonflage. Gonflez les pneus à la pression MAXIMUM indiquée sur le flanc.
 - GENERALITES - Recherchez les pièces détachées ou brisées, vérifiez l'état de la cabine, du tableau de bord, des écrous et des boulons, des autocollants, l'étanchéité des circuits.
- ▲ TOUTES LES 50 HEURES
 - HUILE HYDRAULIQUE, FLEXIBLES ET CONDUITES - Vérifiez le niveau d'huile et faites éventuellement l'appoint. Vérifiez l'état et l'étanchéité des canalisations. Réparez-les ou remplacez-les si nécessaire.
 - TRANSMISSION FINALE (CARTER DE CHAINES, machines sur roues seulement) - Vérifiez le niveau d'huile et faites éventuellement l'appoint.
 - COMMANDES HYDRAULIQUES (PEDALES OU LEVIERS) ET DIRECTION - Vérifiez si elles fonctionnent correctement et réglez-les si nécessaire.
 - ECROUS DE ROUE/BARBOTIN - Vérifiez s'ils ne sont pas desserrés et serrez-les correctement.
 - TENSION DES CHENILLES (machines sur chenilles seulement) - Vérifiez et réglez si nécessaire.
- ▲ TOUTES LES 100 HEURES
 - SILENCIEUX PARE-ÉTINCELLES - Nettoyez la cuve à étincelles (le cas échéant).
 - BATTERIE - Vérifiez l'état de la batterie, des fixations, des câbles, des connexions, et le niveau d'électrolyte. Ajouter de l'eau distillée si nécessaire.
- ▲ TOUTES LES 250 HEURES
 - PIVOTS DE LEVIERS DE DIRECTION - Lubrifiez avec une graisse tous usages à base de lithium (le cas échéant).
 - FILTRE D'ALIMENTATION - Remplacez le filtre.
 - AXES FUSÉES (machines AWS seulement) - Lubrifiez avec une graisse tous usages à base de lithium.
 - ▲ COURROIE D'ENTRAÎNEMENT MOTEUR/HYDRAULIQUE - Vérifiez l'état de la courroie, réglez et remplacez si nécessaire (le cas échéant).
 - ▲ RÉDUCTEUR DU VENTILATEUR - Vérifiez le niveau d'huile et faites l'appoint si nécessaire (le cas échéant).
 - ▲ AUTRES COURROIES D'ENTRAÎNEMENT (pompes hydrostatiques, pompe à eau, alternateur et climatiseur - le cas échéant) - Vérifiez l'état des courroies et leur tension. Réglez-les ou remplacez-les si nécessaire.
- ▲ TOUTES LES 500 HEURES
 - VENTILATEUR DU CIRCUIT HYDRAULIQUE/HYDROSTATIQUE - Remplacez le filtre. Remplacez le bouchon reniflard de réservoir.
 - ▲ FILTRE EN LIGNE DU CLAPET DE DIRECTION (AWS seulement) - Remplacez le filtre.
- ▲ TOUTES LES 1000 HEURES
 - RÉSERVOIR HYDRAULIQUE - Vidangez l'huile.
 - TRANSMISSION FINALE (carter de chaînes sur machines sur roues seulement) - Vidangez l'huile.
 - GALETS ET ROUES DE TENSION (machines sur chenilles seulement) - Vidangez l'huile (le cas échéant).
 - ▲ FILTRE DE RETOUR DE CARTER DU MOTEUR D'ENTRAÎNEMENT - Vidangez l'huile (le cas échéant).
 - ▲ ROULEMENTS DE ROUE ET CANNELURES EXTERIEURES (AWS seulement) - Réparez les roulements, lubrifiez les cannelures internes de l'étrier de moyeu (chez le concessionnaire uniquement).

N.B. :

- ★ Il faut remplacer l'élément de filtre plus tôt si le témoin de transmission reste allumé pendant plus de 5 minutes après que l'huile hydraulique ait atteint sa température de fonctionnement.
 - ▲ Remplacez aux premières 50 heures, ensuite consultez le tableau des entretiens.
 - ▲ Consultez le Manuel de l'Opérateur/Entretien pour le type d'huile à utiliser, le numéro de pièce et l'emplacement du filtre ainsi que pour les intervalles d'entretien correspondant à votre modèle.
- VOIR LE MANUEL DE L'OPÉRATEUR ET D'ENTRETIEN POUR PLUS D'INFORMATIONS.

PLAN DE GRAISSAGE GENERAL

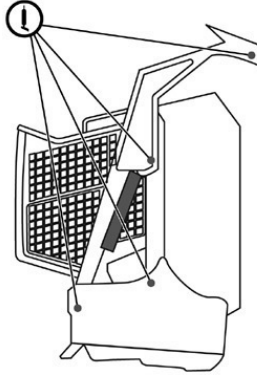

CINEMATIQUE DE LEVAGE RADIALE

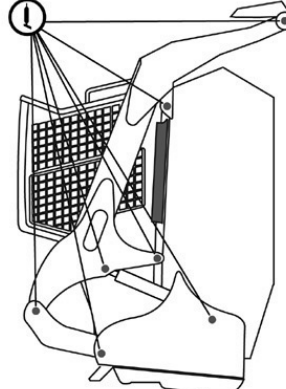

CINEMATIQUE DE LEVAGE VERTICALE



- POINTS DE GRAISSAGE COURANTS



Utilisez des pièces de rechange d'origine Bobcat

70382 SW

6734534D fr

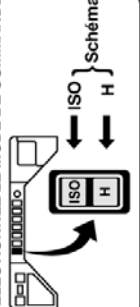
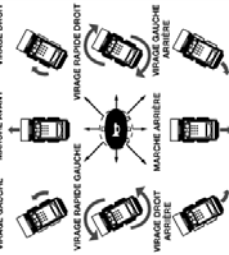
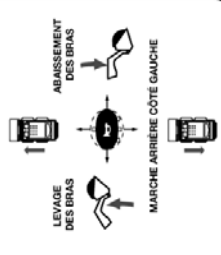
<p>ENTRÉE DANS LA CHARGEUSE</p> 	<p>UTILISATION DE LA CHARGEUSE</p> 	<p>SORTIE DE LA CHARGEUSE</p> 
<h3 style="text-align: center;">INSTRUCTIONS D'UTILISATION DES COMMANDES PAR MANIPULATEUR</h3> <p>POUR UTILISER LA CHARGEUSE :</p> <ol style="list-style-type: none"> 1. Attachez la ceinture de sécurité et abaissez l'arceau de siège. 2. Placez les commandes du manipulateur au point mort. 3. Démarrez le moteur. 4. Sélectionnez le mode de commande (ISO ou H) sur le tableau de bord central. 5. Appuyez sur le bouton "PRESS TO OPERATE LOADER" <ul style="list-style-type: none"> • Le témoin ACS ou d'avertissement général du tableau de bord droit devrait être éteint. • Si les opérations hydrauliques ou de traction ne fonctionnent pas, vérifiez que les deux manipulateurs sont bien au point mort. Redémarrez le moteur. <p>Remarque : actionnez de nouveau le bouton "PRESS TO OPERATE LOADER" si vous avez relevé puis abaissé l'arceau de siège ou si la clé est en position OFF.</p> <p style="text-align: center;">Voir le Manuel et le Guide de l'Opérateur et d'Entretien pour des instructions supplémentaires.</p>		
<p>⚠ AVERTISSEMENT</p> <p>UN MOUVEMENT ACCIDENTEL DE LA CHARGEUSE PEUT PROVOQUER DES BLESSURES GRAVES, VOIRE MORTELLES</p> <ul style="list-style-type: none"> • Les fonctions de traction et de levage se commandent sur un manipulateur différent selon le mode. • Vous devez connaître et comprendre le mode de commande sélectionné avant d'utiliser la chargeuse. <p>SÉLECTIONNEZ LE MODE DE COMMANDE</p> 		
<div style="display: flex; justify-content: space-between;"> <div data-bbox="162 136 446 420"> <p>MANIPULATEUR GAUCHE - ISO</p>  </div> <div data-bbox="446 136 730 420"> <p>MANIPULATEUR GAUCHE - H</p>  </div> </div> <p style="text-align: center;">7131519 fr 07472 SW</p>		

CLICK HERE TO **DOWNLOAD** THE COMPLETE MANUAL

- Thank you very much for reading the preview of the manual.
- You can download the complete manual from: www.heydownloads.com by clicking the link below



- Please note: If there is no response to CLICKING the link, please download this PDF first and then click on it.

CLICK HERE TO **DOWNLOAD** THE COMPLETE MANUAL