



# Bobcat®

---

## Operation & Maintenance Manual Heavy Duty Box Blade

---

(Blade 3HDBB72) S/N AF4N00101 & Above  
(Blade 3HDBB84) S/N AF4P00101 & Above

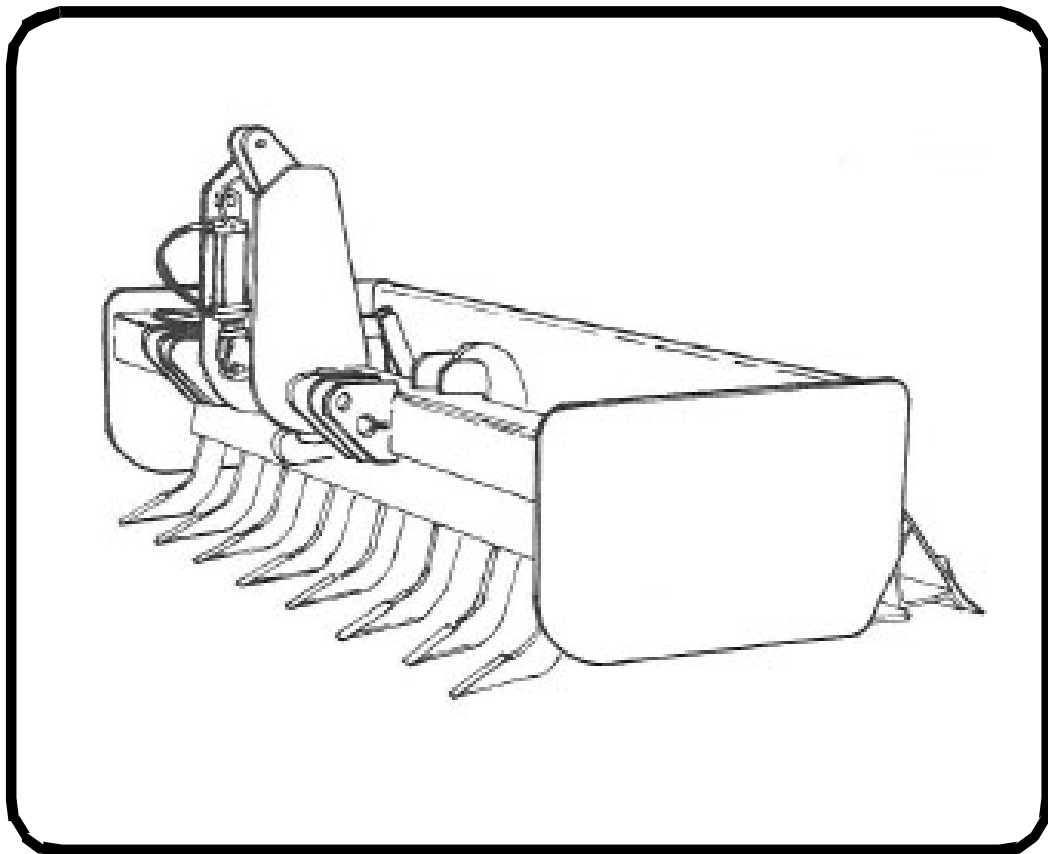

CLICK HERE TO **DOWNLOAD** THE COMPLETE MANUAL

- Thank you very much for reading the preview of the manual.
- You can download the complete manual from: [www.heydownloads.com](http://www.heydownloads.com) by clicking the link below



- Please note: If there is no response to CLICKING the link, please download this PDF first and then click on it.

CLICK HERE TO **DOWNLOAD** THE COMPLETE MANUAL

## **FEATURES AND ACCESSORIES**

### **Standard Items**

The heavy duty box blade is equipped with the following Standard Items:

- Category I and Category II hitch
- Hydraulic lift scarifier
- Two reversible / interchangeable blades
- Adjustable / replaceable scarifier shanks

## IMPLEMENT SIGNS (DECALS)

Follow the instructions on all the Implement Signs (Decals) that are on the implement. Replace any damaged implement signs and be sure they are in the correct locations. Implement signs are available from your Bobcat implement dealer.



02962765



999200

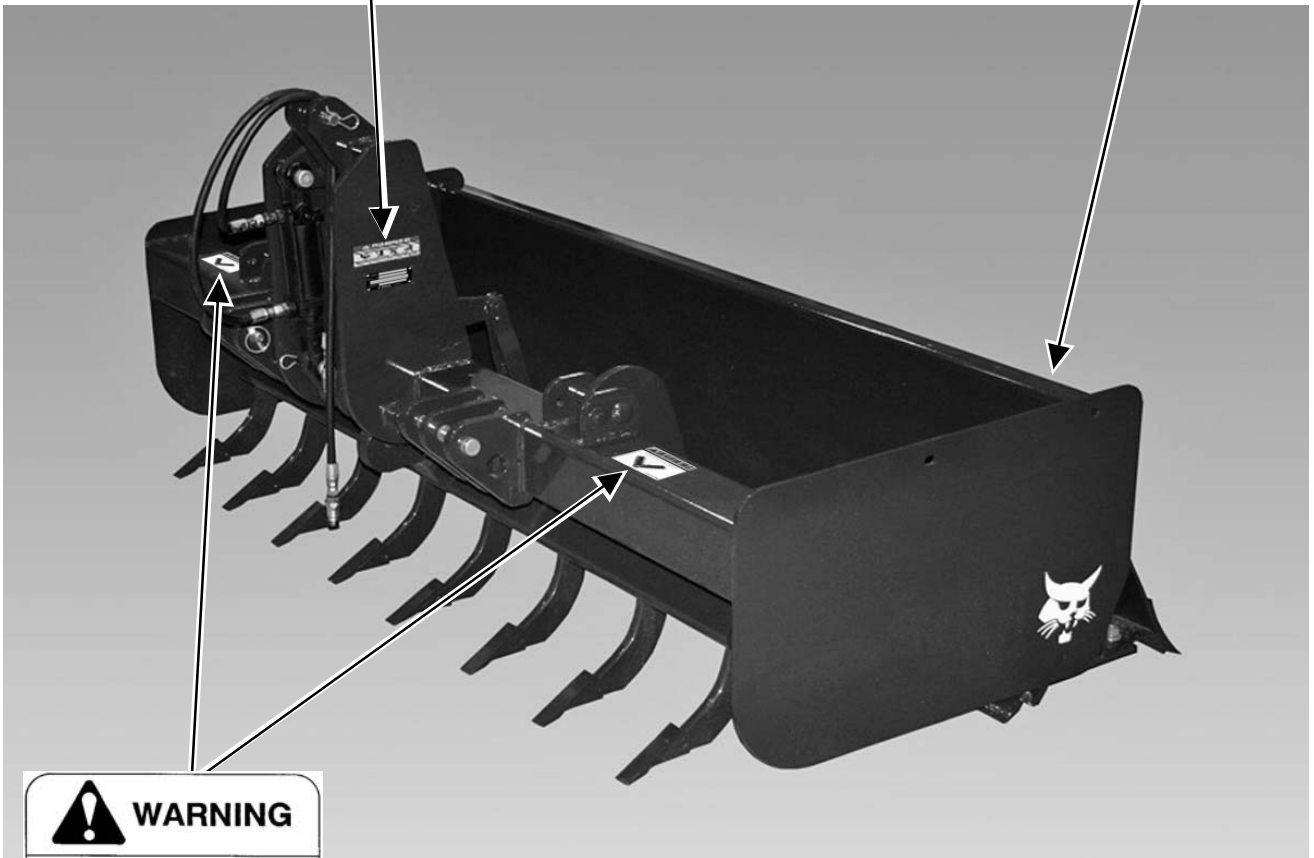

02962764 (2)

P-83586

## OPERATING PROCEDURE WITH UTILITY WORK MACHINE (CONT'D)

### Installation (Cont'd)

#### Three-Point Implement (Cont'd)



## WARNING

### AVOID INJURY OR DEATH

Keep fingers and hands out of pinch points when installing and removing implements.

W-2571-0807

Figure 15

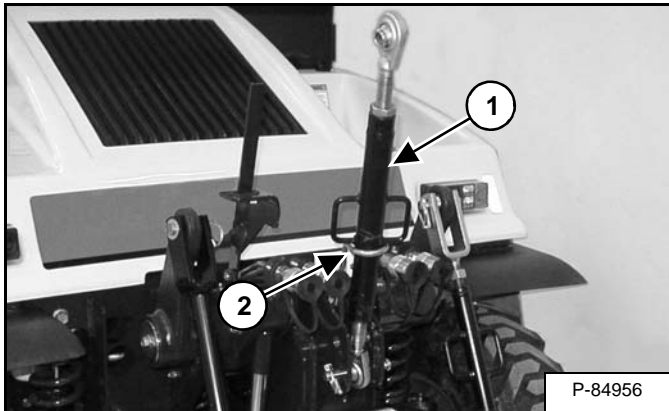

Remove the top link (Item 1) from the storage position bracket (Item 2) [Figure 15].

Figure 16

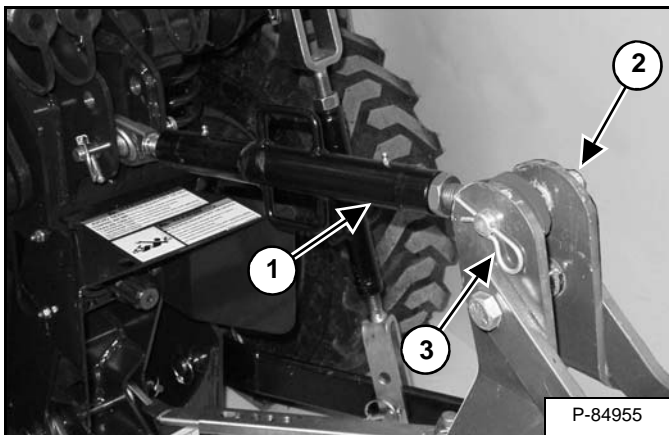

Lower the top link (Item 1) [Figure 16] until it aligns with the implement mounting hole.

Install the pin (Item 2) and retainer pin (Item 3) [Figure 16].

**NOTE:** It may be necessary to lengthen or shorten the top link (Item 1) for pin (Item 2) [Figure 16] alignment. (See Top Link on Page 30.)

Figure 17

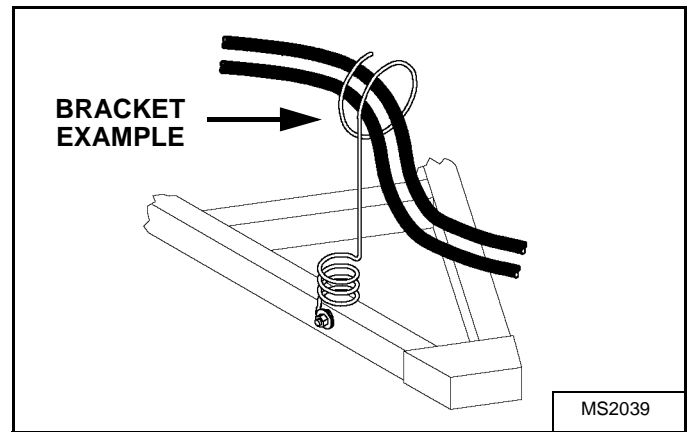

If the implement requires remote hydraulic operation or an electrical harness, connect the hoses to the remote hydraulic quick couplers or the harness to the rear electrical connector. (See Hydraulic Quick Couplers on Page 31.)

Secure hoses and wiring (if applicable) to prevent damage. The illustration in [Figure 17] shows an example of a hose guide bracket on an implement.

## IMPORTANT

To prevent hose damage caused by dragging on the ground, rubbing, pinching or PTO entanglement:

- Support attachment and implement hydraulic hoses using available hose guides or supports.
- Contact your implement or attachment dealer for available hose guides or supports.

I-2230-0907

## OPERATING PROCEDURE WITH COMPACT TRACTORS (CONT'D)

### Installation (Cont'd)

#### Three-Point Implement (Cont'd)

## ! WARNING

### AVOID INJURY OR DEATH

Before backing the compact tractor, look in all directions and make sure no bystanders are in the work area. Do not allow anyone between the compact tractor and the implement when backing up to the implement for installation.

W-2570-0807

Enter the compact tractor. (See Entering And Exiting The Compact Tractor on Page 37.) Start the engine and release the parking brake.

Figure 35

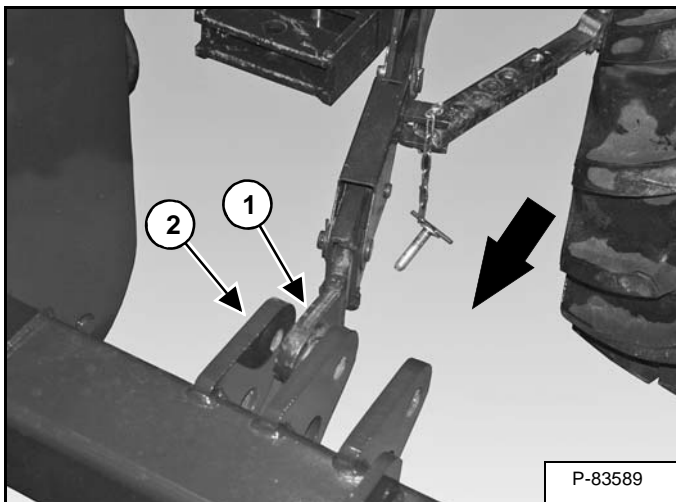

Drive the compact tractor to the implement and align the lower links (Item 1) with the implement lower mounts (Item 2) [Figure 35] (both sides).

Lower or raise the compact tractor's three-point hitch lower links (Item 1) until they are even with the lower mounts (Item 2) [Figure 35] (both sides) of the three-point implement. (See the compact tractor Operation & Maintenance Manual for detailed information on operating the compact tractor.)

Stop the engine and exit the compact tractor. (See Entering And Exiting The Compact Tractor on Page 37.)

## ! WARNING

### AVOID INJURY OR DEATH

Before you leave the operator's seat:

- Fully lower the loader arms, put the attachment flat on the ground (if equipped).
- Fully lower the implement(s) to the ground (if equipped).
- Lock brake pedals together and engage the parking brake.
- Place F-N-R lever in neutral (SST models only).
- Place all controls in neutral.
- Stop the engine, unfasten the seat belt and remove the key.

W-2569-0909

## ! WARNING

### AVOID INJURY OR DEATH

Keep fingers and hands out of pinch points when installing and removing implements.

W-2571-0807

Figure 36

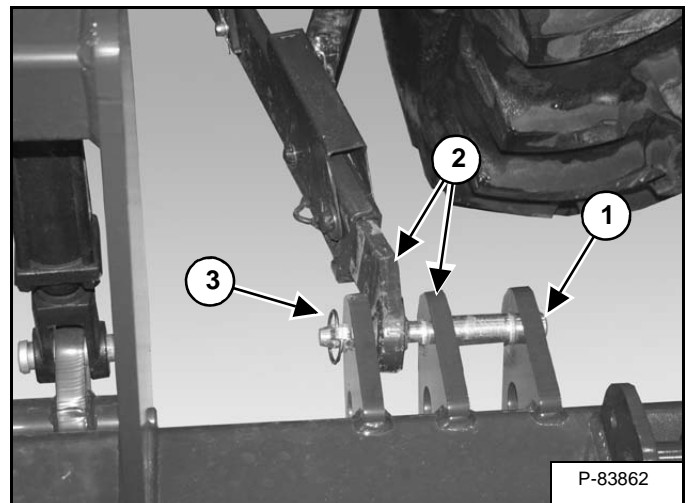

Install the lower implement pin (Item 1) through the lower mounts and lower link (Item 2). Install the retainer pin (Item 3) [Figure 36] (both sides).

The sway bar pins can be removed to help with the installation of the lower links to the implement pins.

**NOTE:** The pin (Item 1) [Figure 36] has two different diameters. A sizing bushing is not required to switch between a Category I and Category II three-point hitch.

## PREVENTIVE MAINTENANCE

TROUBLESHOOTING .....	.51
Chart .....	.51
SERVICE SCHEDULE .....	.52
Description .....	.52
REGULAR MAINTENANCE ITEMS .....	.53
Cutting Edge .....	.53
Scarifier Teeth .....	.53
LUBRICATING THE IMPLEMENT .....	.54
Lubrication Locations .....	.54
REMOVAL AND INSTALLATION OF CUTTING EDGE .....	.55
Procedure .....	.55
REMOVAL AND INSTALLATION OF SCARIFIER TEETH .....	.56
Procedure .....	.56
IMPLEMENT STORAGE AND RETURN TO SERVICE .....	.57
Storage .....	.57
Return To Service .....	.57

## SPECIFICATIONS

HEAVY DUTY BOX BLADE IMPLEMENT SPECIFICATIONS .....	61
Dimensions .....	61
Performance .....	61

CLICK HERE TO **DOWNLOAD** THE COMPLETE MANUAL

- Thank you very much for reading the preview of the manual.
- You can download the complete manual from: [www.heydownloads.com](http://www.heydownloads.com) by clicking the link below



- Please note: If there is no response to CLICKING the link, please download this PDF first and then click on it.

CLICK HERE TO **DOWNLOAD** THE COMPLETE MANUAL