



# Bobcat®

## Operation & Maintenance Manual



### Compact Excavator

S/N B53W11001 & Above



CLICK HERE TO **DOWNLOAD** THE COMPLETE MANUAL

- Thank you very much for reading the preview of the manual.
- You can download the complete manual from: [www.heydownloads.com](http://www.heydownloads.com) by clicking the link below



- Please note: If there is no response to CLICKING the link, please download this PDF first and then click on it.

CLICK HERE TO **DOWNLOAD** THE COMPLETE MANUAL

## Signal Words

The signal words "DANGER", "WARNING", "CAUTION" are used throughout safety messages and safety decals in this manual or on the machine. They indicate an existence of, and the relative seriousness of, a hazard. All three indicate that a safety risk is involved. Observe the precautions indicated whenever a Safety Alert Symbol is present, no matter which signal word appears next to it.

---

### **DANGER**

**DANGER** - This signal word is used on safety messages and safety labels and indicates an imminently hazardous situation which, if not avoided, will result in death or serious injury.

---

### **WARNING**

**WARNING** - This signal word is used on safety messages and safety labels and indicates a potentially hazardous situation which, if not avoided, could result in death or serious injury.

---

### **CAUTION**

**CAUTION** - This signal word is used on safety messages and safety labels and indicates a potentially hazardous situation which, if not avoided, could result in minor or moderate injury.

---

## Other Signal Words

In addition to safety signal words, the following signal words are used to indicate proper and effective use of machine.

---

### **IMPORTANT**

**This signal word identifies procedures which must be followed to avoid damage to machine.**

---

**NOTE:** *The word "NOTE" identifies information for effective use.*

2. Warning Tag - "Do Not Operate" (950205-03802)



AVOID DEATH OR SERIOUS INJURY

- Stop engine and remove key.
- Attach "DO NOT OPERATE" warning tag to the controls before servicing the machine.
- Do not operate when performing inspection or maintenance.

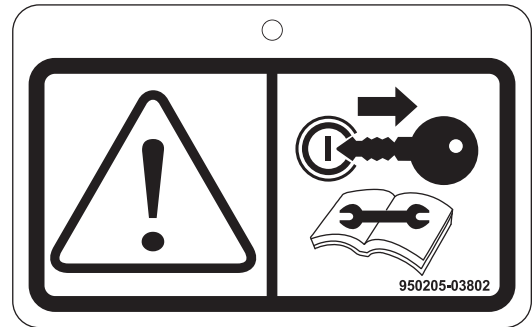

EX1301177

3. Keep Bystanders Away (950205-03803)



AVOID DEATH OR SERIOUS INJURY

- Keep out of swing area and travel path.
- Always look in the travel direction.
- Make sure swing area is clear of bystanders and objects.

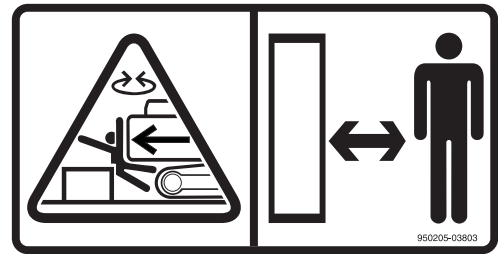

EX1301178

4. Hot Pressurized Fluid (950205-03781)



HOT PRESSURIZED FLUID CAN CAUSE  
SERIOUS BURNS

- Do not loosen or open cap when hot.
- Before opening:
  - 1) Turn engine off.
  - 2) Allow machine to cool.
  - 3) Tip cap and open slowly to relieve pressure.



EX1301180

5. Entanglement in Rotating Parts (950205-03791)



ROTATING PARTS CAN CAUSE DEATH OR  
SERIOUS INJURY

Keep away from belt and rotating parts. Stop engine before servicing.

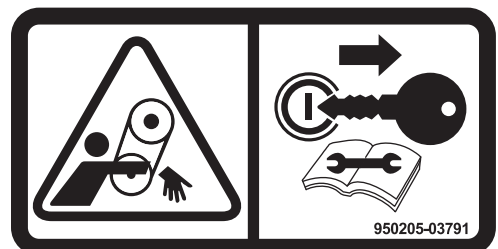

EX1301181

## Proper Work Tools and Attachments

Only use work tools and attachments that are recommended by Bobcat for use on Bobcat machines. When installing and using optional attachments, read instruction manual for attachment, and general information related to attachments in this manual. Because Bobcat cannot anticipate, identify or test all attachments that owners may want to install on their machines, contact Bobcat for written authorization and approval of attachments, and their compatibility with optional kits.

Attachments and attachment control systems that are compatible with the machine are required for safe and reliable machine operation. Do not exceed maximum operating weight (machine weight plus attachment) that is listed on ROPS certification plate.

Make sure that all guards and shields are in place on machine and on work tool. Depending on type or combination of work equipment, there is a potential that work equipment could interfere with the cabin or other parts of machine. Before using unfamiliar work equipment, check if there is any potential of interference, and operate with caution.

While you are performing any maintenance, testing, or adjustments to attachments, stay clear of the following areas: cutting edges, pinch points, and crushing surfaces.

Never use attachment as a work platform or manlift.

Contact your Bobcat dealer about auxiliary hydraulic kits for attachments installation. If you are in doubt about compatibility of a particular attachment with a machine, consult your Bobcat dealer.

## Pressurized Fluids

Pressurized air or fluids can cause debris and/or fluids to be blown out. This could result in death or serious injury.

Immediately after operations are stopped, coolant, engine oil, and hydraulic oil are at their highest temperatures and the radiator and hydraulic tank are still under pressure. Always wait for temperature to cool down. Follow specified procedures when attempting to remove caps, drain oil or coolant, or replacing filters. Always wait for temperature to cool down, and follow specified procedures when performing these operations. Failure to do so can result in death or serious injury.

When pressurized air and/or pressurized water is used for cleaning, wear protective clothing, protective shoes, and eye protection. Eye protection includes goggles or a protective face shield.

Pressure can be trapped in a hydraulic system and must be relieved before maintenance is started.

Releasing trapped pressure can cause sudden machine movement or attachment movement. Use caution if you disconnect hydraulic lines or fittings.

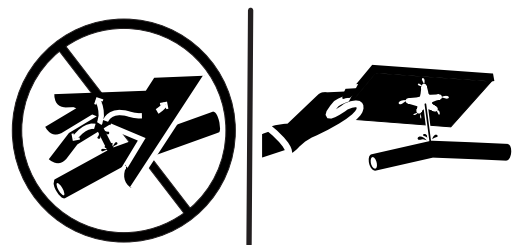

Figure 4

FG018457

### Protecting Cabin from Flying or Falling Objects (Optional)

In a work site where additional operator protection is necessary from falling or flying objects, install adequate protective guards on the cabin.

For breaker operation, install a front guard (1, Figure 20) and apply a laminated coating sheet to front glass. Contact your Bobcat dealer for recommendations.

When performing demolition or cutting operation, install a front guard and top guard.

Apply a protective laminated coating sheet to outside of front window. This will prevent glass from being scratched by dust when cleaning it or running wipers.

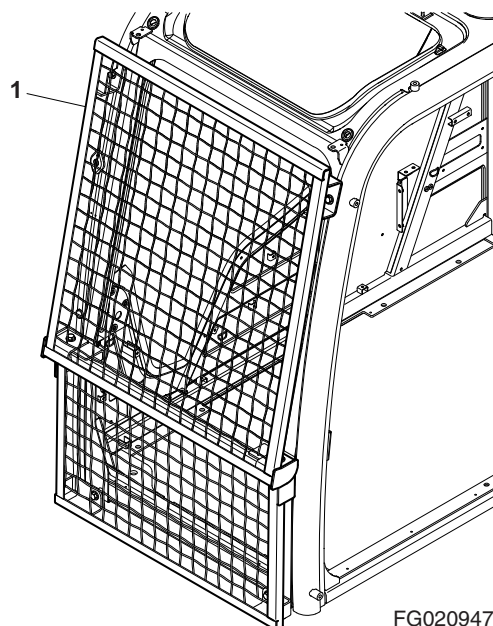

FG020947

Figure 20

When working in mines, quarries or other work sites where there is a hazard of falling rocks, install Operator Protection Guard (OPG) (2, Figure 21) and apply a laminated coating sheet to front glass.

When OPG is installed, and front window needs to be cleaned, loosen bolts marked with arrows (Figure 21). Be sure to tighten bolts when done.

Never attempt to alter or modify any protective structure reinforcement system, by drilling holes, welding, remounting or relocating fasteners. Any serious impact or damage to system requires a complete inspection of the structure. Reinstallation, recertification and/or replacement of system may be necessary.

If any glass on machine is broken, replace it with new glass immediately.

Contact your Bobcat dealer for available safety guards and/or recommendations to protect against objects that could strike operator's cabin. Make sure that all other work site crew members are kept away from excavator when operating.

The excavator must have the front guard kit installed to meet the front guard requirements is ISO 10262 - Level 2.

The excavator must have the top guard kit installed to meet the top guard requirements is ISO 10262 - Level 2.

**NOTE:** *The preceding instructions assume that conditions are for standard operations, but it may be necessary to add additional guards depending on operating conditions or local rules or regulations for the work site. Always contact your Bobcat dealer for advice.*

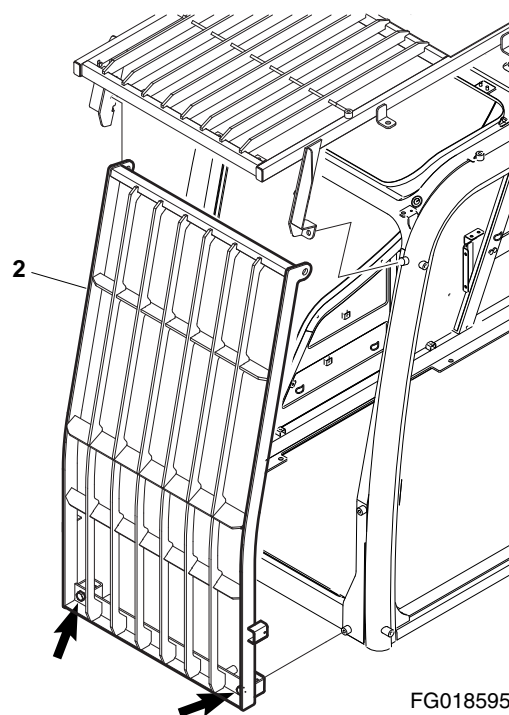

FG018595

Figure 21

## Mirror Adjustment

Frequently ensure the mirrors are directed properly.

- Park the machine on a level surface.
- Lower the attachment to the ground.
- Lower the safety lever to the LOCK position.
- Stop the engine.
- Use the machine access system.

**NOTE:** *You may need hand tools to adjust certain types of mirrors.*

1. Front mirror on the cabin (1, Figure 27).

If equipped, adjust the front mirror on the cabin (1, Figure 27) so the front of the right track can be seen from the operator seat.

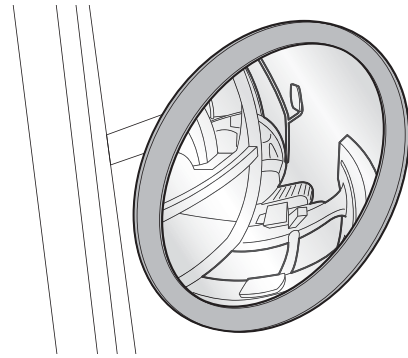

DS1801222

**Figure 28**

2. Front mirror on the cabin (2, Figure 27).

If equipped, adjust the front mirror on the cabin (2, Figure 27) so the front of the left side can be seen from the operator seat.

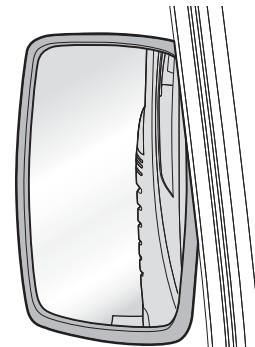

DS1801380

**Figure 29**

3. Additional mirrors other than Figure 27

If equipped, adjust the mirrors whenever you change operators and ensure the mirrors are in proper working conditions.

## Preservation/Storing Machine

Perform the following if storing excavator for more than one month.

Conditions	Maintenance Required
Cleaning	Pressure wash undercarriage and track assemblies. Inspect for damage or loose or missing parts.
Lubrication	Perform all daily lubrication procedures.
	Apply a coating of light oil to exposed plated metal surfaces, such as hydraulic cylinder rods, etc.
	Apply a coating of light oil to all control linkages and control cylinders (control valve spools, etc.)
Battery	Turn "OFF" the battery disconnect switch.
Cooling System	Inspect coolant recovery tank to make sure that antifreeze level in system is at correct level.
	Every 90 days, use a hydrometer to measure protection level of coolant. Refer to "Antifreeze Concentration Tables" on page 4-86, to determine amount of protection cooling system requires. Add coolant as required.
Hydraulic System	Once a month, start engine and follow procedures in "Hydraulic System Warm-up" on page 3-14, listed in this manual.

1. Complete the preceding steps.
2. Wash machine and touch up paint finish to avoid rusting.
3. Treat exposed parts with antirust agent, lubricate machine thoroughly and apply grease to unpainted surfaces like lifting and tilting cylinders etc.
4. Fill fuel tank and hydraulic oil tank to "FULL" marks.
5. Cover exhaust pipe (parking outside).
6. Make sure that coolant is at proper concentration for expected lowest temperatures.
7. Park machine on level, firm ground where there is no risk of freezing, landslide or flooding. Avoid parking machine on a slope.

Keep in mind that theft and burglary risk can be minimized by:

- Removing starter key when the machine is left unattended.
- Locking doors and covers after working hours.
- Turning off electrical current with battery disconnect switch.
- Park machine where risk of theft, burglary and damage is minimized.
- Removing valuables from cabin such as cellular phone, computer, radio and bags.

See "Long Term Storage" on page 3-70, for more information.

Since there is a potential hazard that sparks could be generated, always do the following:

- Do not let tools, rings or other metal objects make any contact between battery terminals. Do not leave tools or other metal objects lying near battery.
- When disconnecting battery terminals, wait for approximately one minute after turning engine starter switch key to "O" (OFF) position, and be sure to disconnect grounding terminal; negative (-) terminal first. Conversely, when connecting them, begin with positive (+) terminal and then grounding (-) terminal, Make sure that all terminals are connected securely.
- Flammable hydrogen gas is generated when battery is charged. Remove battery from machine, take it to a well ventilated place, and remove battery caps, before charging it.
- After charging, tighten battery caps securely.
- After charging, secure battery back in machine.

When repairing or welding electrical system, wait for approximately one minute after turning engine starter switch key "OFF". Then disconnect negative (-) terminal of battery to stop flow of electricity.

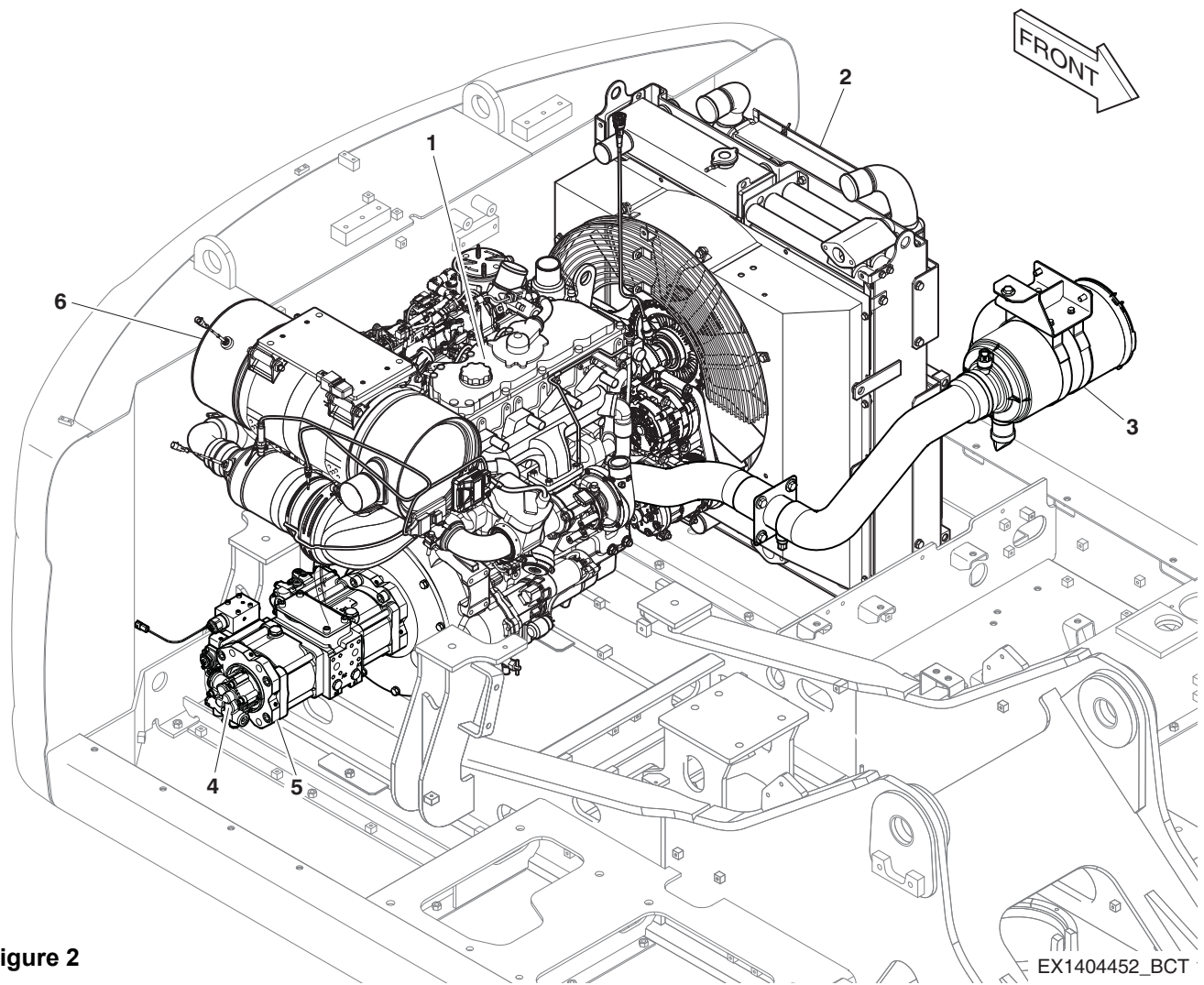

Figure 2

Reference Number	Description
1	Engine
2	Radiator
3	Air Cleaner

Reference Number	Description
4	Pilot Pump
5	Main Pump
6	SCR Muffler

## 8. Light Switch

This switch is used to turn "ON" the lights.

- O. In this position, all lights are "OFF".
- I. In this position, all illumination lights of the display monitor and the control switches are turned "ON".
- II. In this position, all illumination lights, Head light and front work lights are turned "ON".

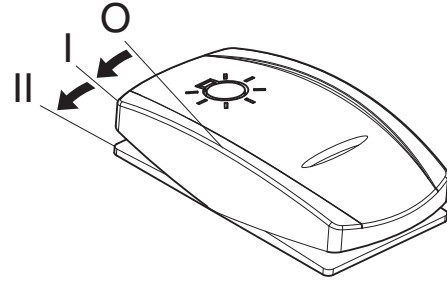

FG016017

Figure 14

## 9. Not Used

## 10. Cabin Work Light Switch (Optional)

This switch is used to control the cabin work lights, if unit is equipped with them.

- O. In this position, all cabin work lights are turned "OFF".
- I. In this position, the front cabin work lights on the front top of cabin will turn "ON".
- II. In this position, the front cabin work lights on the front top of cabin and rear cabin work lights on rear top of cabin will turn "ON".

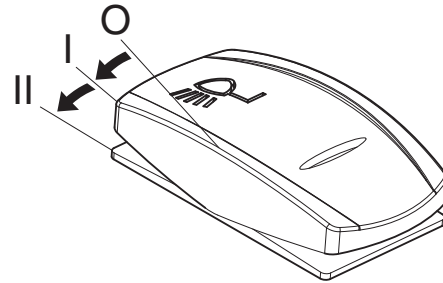

FG016019

Figure 15

## 11. Audio Control Panel

The audio system can be remotely controlled using this panel.

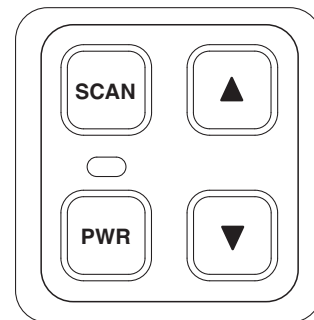

FG000018

Figure 16

## 6. Multimedia Button

Used to select window for video and music (MP3).

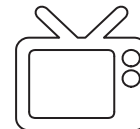

FG018108

Figure 45

## 32. Aux / USB Port

### 1. USB Port

Used for playing a video or MP3 file on the display monitor.

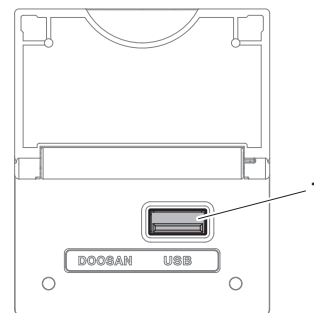

DS1800291

Figure 46

## 33. Not Used)

12. DEF (AdBlue®) Low Level Warning Symbol



FG019175

Figure 72

Reductant Level	Inducement Trigger	Notification	Inducement
Normal Operation	> 20% DEF Level		
Initial Indication	< 20% DEF Level	Low DEF Light	None
Level 1	< 14% DEF Level	Low DEF Light + Constant Symbol	None
Level 2	< 8% DEF Level	Low DEF Light + Flashing Every 2 sec.	None
Level 3	< 3.5% DEF Level	Low DEF Light + Flashing Rapidly Every 0.5 sec.	Idle Only

## Launch Menu

Items that are frequently used from the display monitor are configured into a launch menu to improve accessibility of features of the equipment.

### 1. User Menu

Use this to access the user menu from the display monitor.

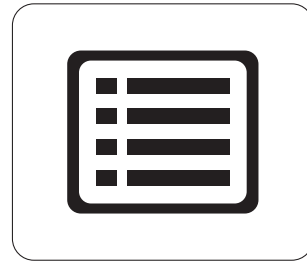

EX1301394

Figure 100

### 2. Entertainment Video

Use this launcher symbol to access the Video menu when using the video feature among the entertainment features.

**NOTE:** *This menu is activated when the USB device is connected to Aux / USB port.*

*Function only available when the safety lever is in the locked position.*

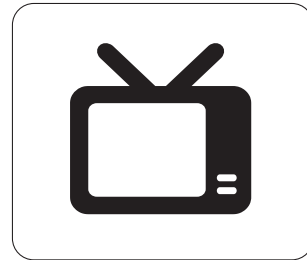

EX1301395

Figure 101

### 3. Entertainment MP3 Player

Use this launcher symbol to access the MP3 menu when using the MP3 feature among the entertainment features.

**NOTE:** *This menu is activated when the USB device is connected to Aux / USB port.*

*Function only available when the safety lever is in the locked position.*

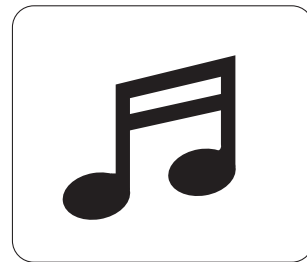

EX1301396

Figure 102

If the remaining time for filter/oil replacement is less than 10 hours, this pop-up window will be created. Press the ESC button or the jog switch to allow the pop-up window to disappear.

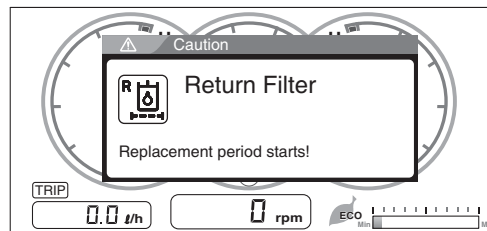

DS1601352

Figure 124

If the filter/oil replacement period is exceeded, this pop-up window will be created. Press the ESC button or the jog switch to allow the pop-up window to disappear.



**WARNING**

**AVOID DEATH OR SERIOUS INJURY**

**Do not use machine state menu when traveling or operating.**

C. Machine Information

This is used to check the machine name, engine type and attachment options.

At the machine state, if the cursor is placed on the machine information, click the jog switch to access the machine information screen.

Click the ESC button to return to the previous screen.

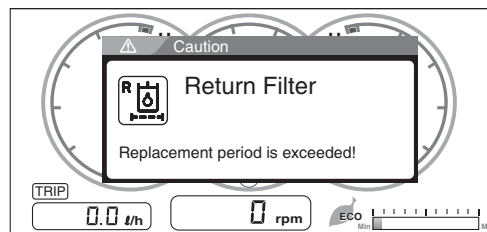

DS1601353

Figure 125

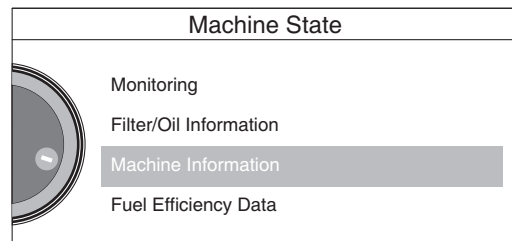

DS1601354

Figure 126

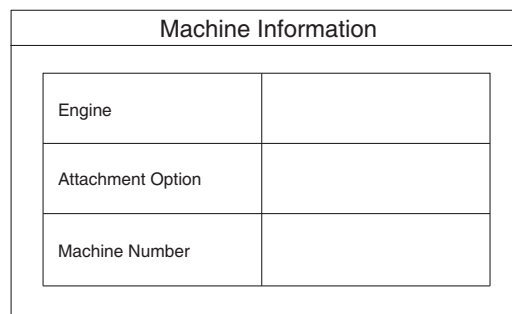

WE1500736

Figure 127

When the cursor is placed at the selector dial, if you click on the jog switch, a pop-up window will be created, saying "Do you want to use manual Dial Control for Engine rpm?".

Operate the jog switch and select "YES/NO" to determine whether to use jog shuttle for dial.

If you select "YES", then selector dial is enabled, causing the pop-up window to disappear.

If you select "NO", then selector dial remains disabled, causing the pop-up window to disappear.

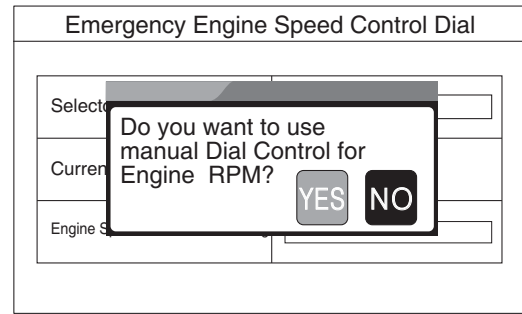

DS1601362

Figure 154

If the selector dial is shown as enable, operate the jog switch clockwise and move the cursor to the setting rpm dial. When the cursor is placed at the setting rpm dial, click on the jog switch to cause the cursor to flicker, changing into an editing mode to set up the rpm dial. When the cursor is placed at the editing mode, operate the jog switch clockwise/ counterclockwise, thus setting up the engine rpm.

When the cursor is at the editing mode, press the ESC button to disable the editing mode. When the cursor is not at the editing mode, press the ESC button to return to the previous screen.

Before keying off the gauge panel or disabling the selector dial, control the engine rpm only with the shuttle of the gauge panel's jog shuttle.

D. Auto Shut-off Setting

In the auto shut-off setting screen, the engine of the equipment can be set to shut off automatically when the equipment is not operated for a preset time.

Select auto shut-off setting in the machine settings and proceed to the setting screen.

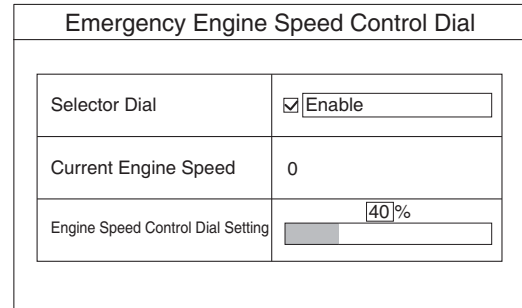

DS1601363

Figure 155

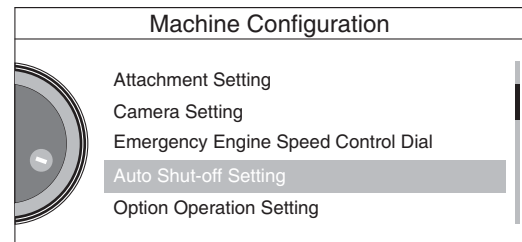

DS1601785

Figure 156

In the auto shut-off setting screen, the cursor will initially be over auto shut-off function in use.

To use the feature, place the cursor over auto shut-off function in use and click the jog switch to select the feature.

The engine can be set to shut off automatically after a maximum of 60 minutes to a minimum of 3 minutes.

In factory defaults, the time is set to 5 minutes. Further, this feature is off in factory defaults.

The following conditions must be met if this feature is to be used.

Auto Shut-off (ASD) Active Condition

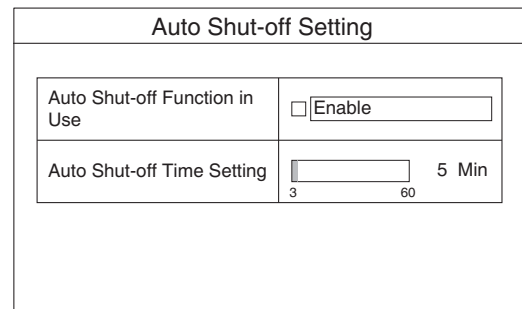

DS1601365

Figure 157

- a) Engine startup  
Setting of password input upon operation of equipment.
- b) Attachment setting  
Setting of password input for attachment setting.
- c) Entertainment use setting  
Setting of password input for entertainment (video/MP3) use setting.

**Engine start-up setting**

By selecting "Engine Start-up" among item settings the reentry time for password entry upon start-up of the equipment can be set.

**NOTE:** *No password for start-up of the equipment is set by default.*

- a) Always  
Password is entered with each start-up.
- b) 1 min  
If the system is started again within 1 minute from key-off after the password is input, the password is not requested again.
- c) 5 min  
If the system is started again within 5 minutes from key-off after the password is input, the password is not requested again.

**Operator password setting**

- a) Operator password use setting  
Sets use of the operator password.
- b) Operator password change  
After setting use privileges for the operator password, the owner can change the operator password.

Password Setting	
Owner	Password Change <input checked="" type="radio"/> Always <input type="radio"/> 1min <input type="radio"/> 5min
	Item Setting
	<input type="checkbox"/> Enable Operator Password
Operator	Password Change

DS1603037

**Figure 186**

Password Setting	
Owner	Password Change Engine Startup Lock has not been set!
	Item Setting
	<input checked="" type="checkbox"/> Enable Operator Password
Operator	Password Change

DS1603038

**Figure 187**

# Switch Operation Indication

## Enable

During the operation of switches for pressure increase, breaker, shear, travel, working light, parking and quick coupler, this function indicates a relevant switch symbol at the left top or bottom. It displays the operation state on the screen.

## Operation Indication Examples

1. Power Plus Mode Selection

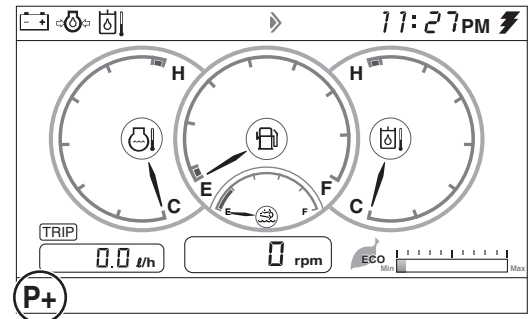

EX1301016

Figure 214

2. Power Mode Selection

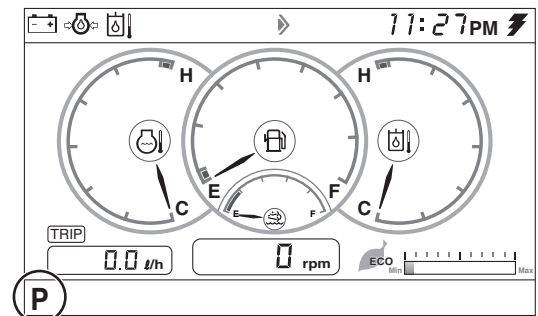

EX1301017

Figure 215

3. Standard Mode Selection

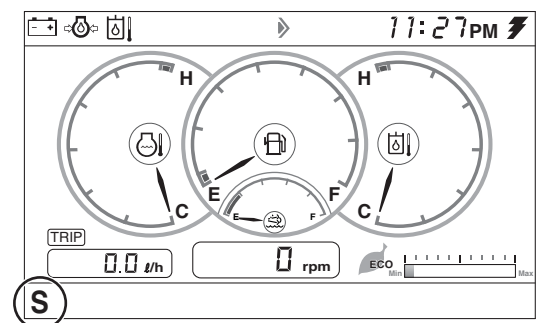

EX1301018

Figure 216

# MISCELLANEOUS ELECTRICAL DEVICES

## Cabin Light

A light is installed on the top of the operator's cabin.

The light will work despite starter switch position.

**NOTE:** *If light is left "ON" for a long time while the engine is not running, the battery will be discharged.*

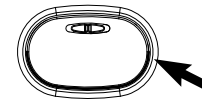
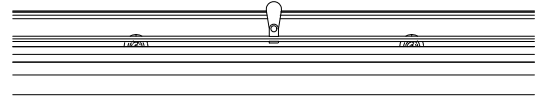

©

FG015827

Figure 241

## Safety Lever

When the safety lever is moved into "LOCK" position, the switch deactivates the work and travel levers. With the work and travel levers deactivated, no digging/operational work can be done.

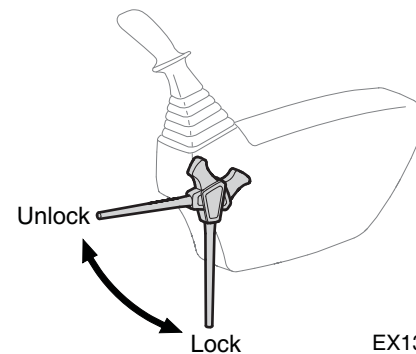

EX1300566

Figure 242

## Circuit Breaker (80 A)

A main circuit breaker is in the battery box. It will automatically cut off in case of an electrical short circuit or overload. This will prevent the electrical wiring and components from being burned or damaged.

If the circuit breaker is cut off, check all related circuits. This means something is wrong in the electrical circuit and it needs to be repaired.

After maintenance, press the red button for normal operation of circuit breaker.

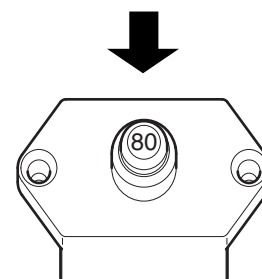

FG018291

Figure 243

## Closing Window

Reverse the removal procedure.

---

# IMPORTANT

---

**Make sure that bottom window is properly seated in bottom of the front cabin window opening. Closing upper window with bottom window unattached can damage bottom window.**

---

## Door Side Latch

1. The door side latch (1, Figure 262) is used to secure door to side of cabin when it is opened.

**NOTE:** *Keep door closed and locked when machine is not in use.*

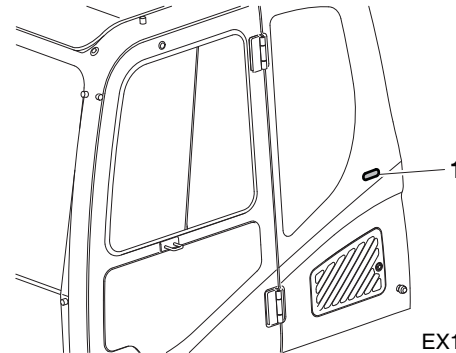

Figure 262

EX1300814

2. To release door from side of cabin, push latch lever (2, Figure 263) down. The latch lever is to the left of operator's seat.

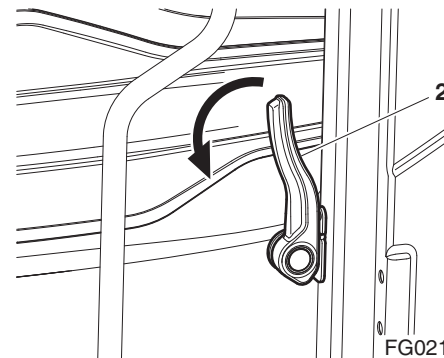

Figure 263

FG021421\_BCT

CLICK HERE TO **DOWNLOAD** THE COMPLETE MANUAL

- Thank you very much for reading the preview of the manual.
- You can download the complete manual from: [www.heydownloads.com](http://www.heydownloads.com) by clicking the link below



- Please note: If there is no response to CLICKING the link, please download this PDF first and then click on it.

CLICK HERE TO **DOWNLOAD** THE COMPLETE MANUAL

## Operational Checks Before Starting Engine

1. Turn battery disconnect switch to "ON" position (Figure 1).

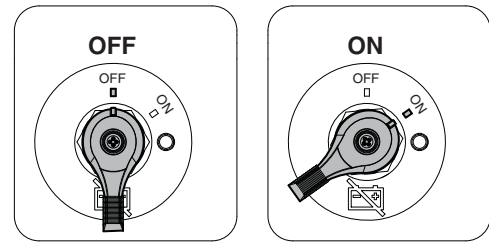

EX1500481

Figure 1

---

### **WARNING**

---

#### **AVOID DEATH OR SERIOUS INJURY**

When leaving operator's seat, move the safety lever to "LOCK" (Figure 2) position and stop engine to prevent accidental activation of the work levers and controls.

---

2. Move safety lever to "LOCK" position (Figure 2).
3. Fasten seat belt. Check for proper operation and condition.
4. Set all operation levers in "NEUTRAL".

**NOTE:** *Be careful not to move any switches when starting engine.*

5. Rotate the starter switch to "I" (ON) position (Figure 3). Check all indicator lights. Warning buzzers will sound for about two seconds. After two seconds, all lights except the following will turn "OFF".

**NOTE:** *Quick coupler release system has a different buzzer sound.*

- Charging warning light
- Engine oil pressure warning light
- Engine coolant temperature gauge
- Fuel gauge
- Hydraulic oil temperature gauge
- Engine rpm (0 rpm) digital readout

**NOTE:** *If all the indicator lights do not come "ON" when the key is first turned, there is a problem.*

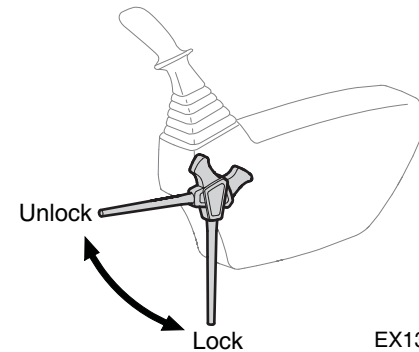

EX1300566

Figure 2

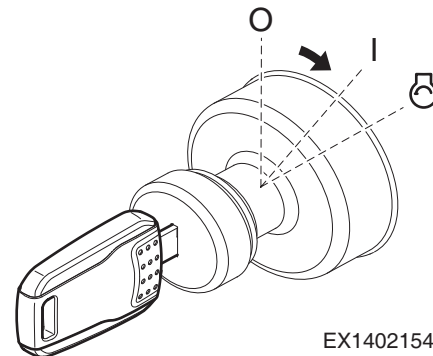

EX1402154\_BCT

Figure 3

2. Move safety lever (Figure 18) to "UNLOCK" position.

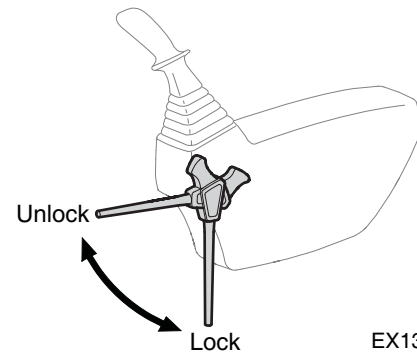

Figure 18

EX1300566

3. Slowly cycle boom, arm and bucket cylinders about five times without a load to circulate the oil through the system. Do this for five (5) minutes.
4. Check for clearance and fully raise the front attachment. Swing clockwise three (3) revolutions. Swing counterclockwise three (3) revolutions.
5. Travel forward and reverse at low speed for two (2) revolutions of the drive sprocket.

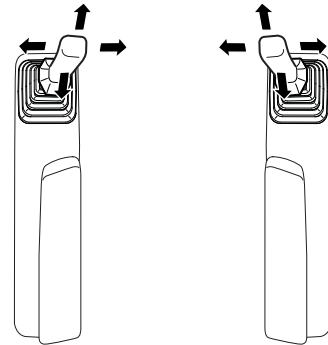

Figure 19

FG018384

## Hydraulic System Warm-up – Cold Weather

1. Run engine at "LOW IDLE" (no load) for five (5) minutes (Figure 20).

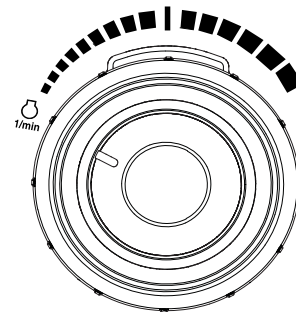

Figure 20

FG018152

2. Run engine for approximately five (5) minutes set at the middle of the speed range, without a load (Figure 21).

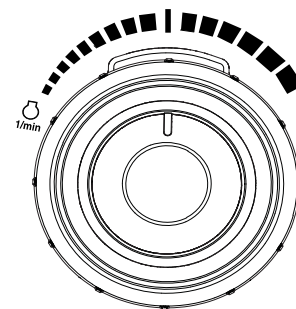

Figure 21

FG018151

# OPERATING INSTRUCTIONS

## Engine Speed Control

Engine speed can be manually adjusted using the engine speed control dial. Increase engine speed by rotating the control knob clockwise. Decrease engine speed by rotating the control knob counterclockwise.

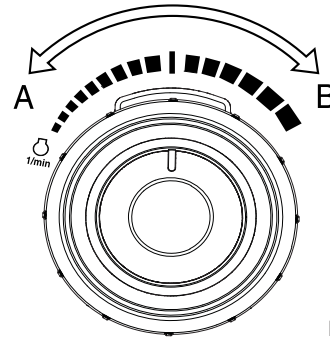

FG018094

Figure 45

## IMPORTANT

The engine speed control system has been set at the factory and should not require adjustment as part of routine maintenance.

## Emission Control System

This machine is equipped with an engine exhaust emission control system that meets applicable engine EPA/CARB/EU exhaust emission regulations. The owner/operator is responsible for proper operation and maintenance of the emission control system as provided in this manual and the emissions-related warranty provisions. The system provides a warning if there are faults in the Selective Catalytic Reduction System (SCR) system or if the level of DEF (AdBlue®) in the DEF (AdBlue®) tank is too low.

### Low DEF (AdBlue®) Level



FG019175

Figure 46

DEF (AdBlue®) Low Level Warning Symbol

Reductant Level	Inducement Trigger	Notification	Inducement
Normal Operation	> 20% DEF Level		
Initial Indication	< 20% DEF Level	Low DEF Light	None
Level 1	< 14% DEF Level	Low DEF Light + Constant Symbol	None
Level 2	< 8% DEF Level	Low DEF Light + Flashing Every 2 sec.	None
Level 3	< 3.5% DEF Level	Low DEF Light + Flashing Rapidly Every 0.5 sec.	Idle Only

- When working close to the excavated edge or drop-off, make sure that the machine is sitting on solid ground. Keep the travel motors (1, Figure 65) to the rear. See Figure 65.

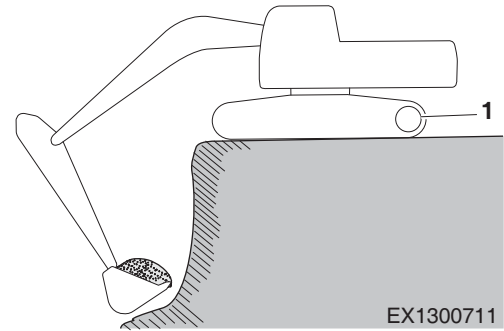

**Figure 65**

- Do not allow bottom side of the boom to interfere with or touch the ground or track when digging a deep hole. See Figure 66.

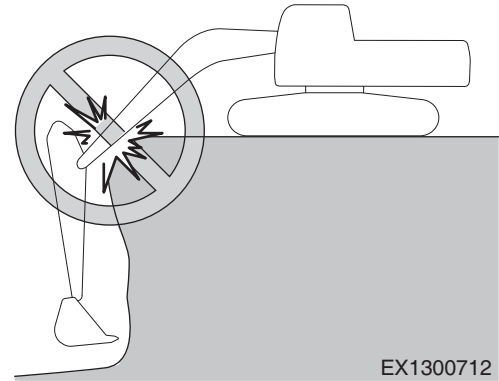

**Figure 66**

- Do not excavate underneath the machine. The ground under the machine can collapse and cause the machine to fall and roll-over. See Figure 67.

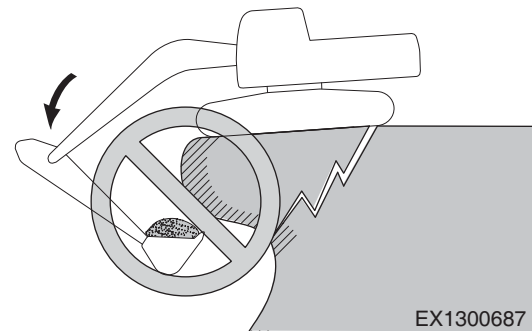

**Figure 67**

- Make sure there is adequate clearance from overhead electrical supply lines. Check for underground utility lines before excavating. Call before you dig. See Figure 68.

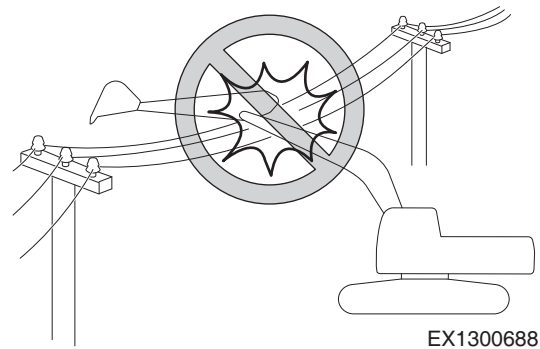

**Figure 68**

# HYDRAULIC ATTACHMENTS (OPTIONAL)

## Quick Coupler Operation (S/N 1011 & Below)

**NOTE:** *The quick coupler installed on your machine may be different than the one shown in this manual. Always read and follow the manufacturer's Quick Coupler Owner's Manual for more instructions.*

### To Engage Attachment

---



## WARNING

---

### AVOID DEATH OR SERIOUS INJURY

The following safety instructions are for your safety, the safety of bystanders, and to prevent property damage. Read the instructions before using the machine and make sure you are familiar with all safety messages and decals.

Hydraulic quick couplers must be installed, operated, inspected, serviced, maintained and repaired by properly trained and experienced people.

- Do not operate the machine if there are other workers or people in the work area. Also, never allow people to stand or walk under the work tool or attachment while operating.
  - Do not start or perform any work unless you are properly trained. You should understand how to use the quick coupler according to the instructions.
  - Make sure that quick coupler is "FULLY ENGAGED AND LOCKED" every time after you change work tools or attachments.
  - Perform the recommended daily inspection and maintenance for proper operation.
  - Attachments used with the machine should not exceed the rated capacity and load limits of the excavator.
  - Check for changes to load radius, maximum operating capacity and read and follow load rating charts before lifting loads or objects.
-

14. Visually check that quick coupler is fully engaged and locked before operating the machine and attachment.

---

**! WARNING**

---

**AVOID DEATH OR SERIOUS INJURY**

Failure to visually check that quick coupler is "FULLY ENGAGED AND LOCKED" before operating can allow the attachment to fall off causing death or serious injury.

---

---

**! WARNING**

---

**AVOID DEATH OR SERIOUS INJURY**

The attachment swing radius is increased when the quick coupler is installed.

Operate quick coupler and attachment through its full range of motion to check for interference between attachment and machine that could damage the cabin, boom, coupler or attachment.

---

---

**! WARNING**

---

**AVOID DEATH OR SERIOUS INJURY**

Never use quick coupler or attachment to transport or lift persons. Always use quick coupler and attachment according to the instructions provided by the manufacturer.

---

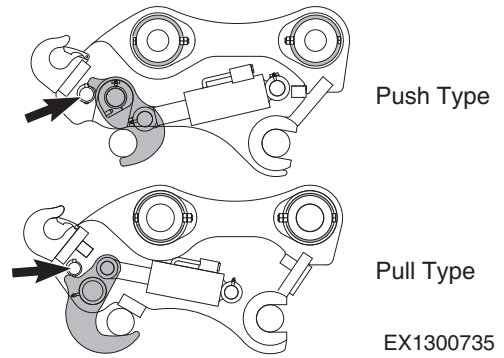

Figure 118

# LIFTING OBJECTS

---

## IMPORTANT

---

**There may be local or government laws or regulations governing the use of excavators for the lifting of heavy loads. Always contact local and government agencies and follow all applicable laws and regulations.**

---

When this machine is used in object handling applications, the machine must be properly configured and operated. Ensure the following safety working devices are equipped and operational.

- Lifting eye for load hooking.

To prevent injury, do not exceed the rated load capacity of the machine. If the machine is not on level ground, load capacities will vary.

Short slings will prevent excessive load swing.

Use the lifting eye on the bucket that is provided to lift objects.

Always try to maintain the lifting eye (Figure 139) straight below the centerline of the arm and bucket pin. In this manner the weight of the load is being primarily held only by the pin, and not by the bucket cylinder, link, and link pins.

When a lifting eye is used, the sling/lifting device must be fastened to the eye in a manner that will not allow it to come loose.

The highest lift capacity of the machine is over the front and rear of the machine.

If the machine is equipped with a dozer, the highest lift capacity is over the rear (Figure 139).

For best stability, carry a load as close to the ground and machine as possible.

Lift capacity decreases as the distance from the machine swing centerline is increased.

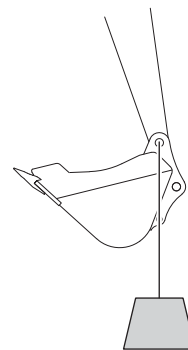

**Figure 139**

EX1300739

## **Safety Precautions**

1. Clean up any fluid spills, especially around engine.
2. Inspect all fuel lines to make sure that fittings, lines, filters, O-rings, etc. are tight and are not showing signs of leakage, wear or damage.
3. If inspection or test procedure requires that engine be running, make sure to keep all bystanders away from the machine.

# ELECTRICAL SYSTEM MAINTENANCE

- If electrical equipment becomes wet or covering of wiring is damaged, this will cause an electrical short circuit and result in improper machine operation. Do not wash inside of operator's cabin with water. When washing the machine, be careful not to let water get into electrical components.
- Service relating to the electrical system is: checking fan belt tension, checking damage or wear to the fan belt, and checking battery electrolyte level.
- Never install any electric components other than those specified by Bobcat.
- External electromagnetic interference can cause malfunction of the control system controller. Before installing a radio receiver or other wireless equipment, contact your Bobcat dealer to prevent electromagnetic interference.
- When working in saltwater areas or in or around snow, carefully clean the electrical system to prevent corrosion.
- When installing electrical equipment, connect it to the special power source connector.

Do not connect the optional power source to a fuse, starter switch, or battery relay.

<b>SERVICE ITEM</b>	<b>PAGE</b>
Check Fluid Levels in Batteries	4-45
Inspect for Any Loose or Missing Nuts and Bolts	4-45
Inspect Fuel System Hose Clamps	4-45
<b>500 Hour / 3 Month Service</b>	
Perform All Daily, 50 and 250 Hour Service Checks	4-46
Grease Swing Gear and Pinion	4-46
Change Engine Oil and Filter	4-47
Clean Air-conditioning Outer Filter	4-49
Check and Clean Air-conditioning Inner Filter	4-50
Clean Radiator, Oil Cooler, Intercooler, Fuel Cooler and Air Conditioner Condenser Cores	4-51
Clean Outer Filter of Air Cleaner	4-52
Replacement of Water Separator & Pre Fuel Filter (Fuel Prefilter)	4-54
Change Main Fuel Filter	4-55
Check Oil Level in Travel Motor (One on Each Side of Unit)	4-56
Change Oil in Travel Motor (One on Each Side of Unit) (After First 500 Hours)	4-56
Change Oil in Swing Motor (Drain and Refill After First 500 Hours)	4-56
<b>1,000 Hour / 6 Month Service</b>	
Perform All Daily, 50, 250 and 500 Hour Service Checks	4-57
Grease Swing Motor	4-57
Change Hydraulic Oil Tank Breather Filter	4-57
Replace Hydraulic Oil Return Filter	4-58
Change Pilot Filter	4-59
Change Oil in Travel Motor (One on Each Side of Unit)	4-60
Change Oil in Swing Motor	4-61
Change Air-conditioning Outer Filter	4-62
Change Air-conditioning Inner Filter	4-63
Check Engine Fan and Alternator Belts Tension	4-64
Change Fuel Cap Filter	4-65
Check and Adjust Engine**	4-66
<b>1,500 Hour / 9 Month Service</b>	
Perform All Daily, 50, 250, 500 and 1,000 Hour Service Checks	4-67
Change DEF (AdBlue®) Filter	4-67
Replace Engine Crankcase Breather Element	4-68
<b>2,000 Hour / Yearly Service</b>	
Perform All Daily, 50, 250, 500, 1,000 and 1,500 Hour Service Checks	4-69
Replace Outer and Inner Air Cleaner Filters	4-69
Change Radiator Coolant	4-71
Hydraulic Oil Exchange and Suction Strainer Cleaning	4-73
Check Alternator and Starter**	4-75
Check All Cab Mounts	4-75
Perform and Record Results of Cycle Time Tests	4-75
Inspect Machine to Check for Cracked or Broken Welds or other Structural Damage	4-75

## Check Cooling System and Refill As Required



### WARNING

#### AVOID DEATH OR SERIOUS INJURY

Allow the engine to cool before releasing the radiator cap. Loosen the cap slowly to release any remaining pressure.

Do not remove radiator cap unless it is required. Check the coolant level in the coolant recovery tank.

**NOTE:** Do not mix ethylene glycol and propylene glycol antifreeze together.

1. When the engine is cold, check the coolant level inside the surge tank. Refer to coolant concentration table. (See page 4-86)
2. Check to make sure that coolant transfer line from the surge tank to the radiator and the engine water pump are free and clear of obstructions, or is not pinched.
3. Check the level of coolant in the surge tank. The normal cold engine fluid level must be between "FULL" and "LOW" marks on tank.
4. If the coolant is below the "LOW" mark, add pre-mixed coolant to the tank.

**NOTE:** When refilling or replacing coolant, select "heater-full hot" mode to fully open the water valve. Coolant will then flow into the heater's core to prevent air from being trapped in it.

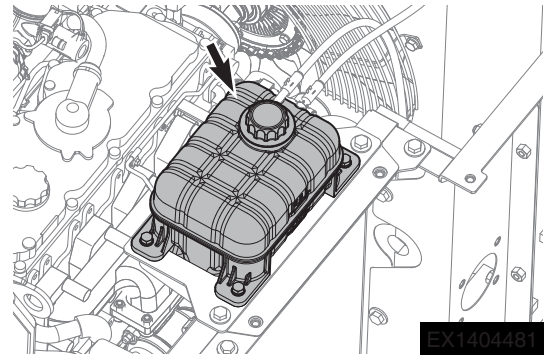
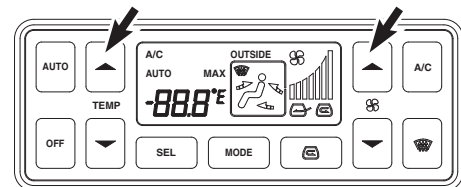

Figure 31



EX1502248

Figure 32

## Check Level of Window Washer Liquid

1. Open left front access door and check fluid level in windshield washer tank.
2. Open fill cap and add fluid.

**NOTE:** Use a washer liquid that is rated for all seasons. This will prevent freezing during cold weather operation.

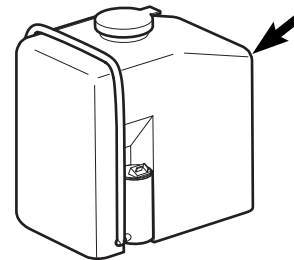

FG020184

Figure 33

A. Boom cylinder head pin (2 points)

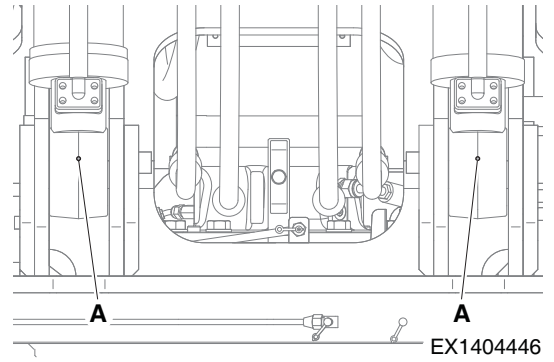

Figure 44

- B. Boom foot pin (2 points)
- C. Boom cylinder rod pin (2 points)
- D. Arm cylinder head pin (1 point)

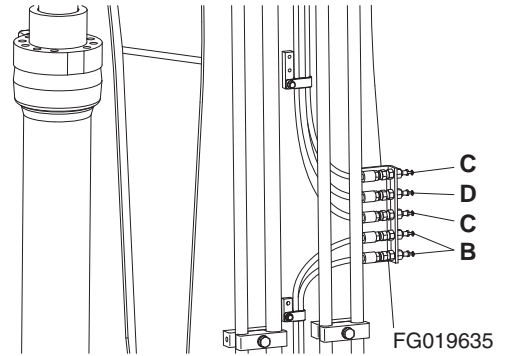

Figure 45

- E. Boom arm joint pin (2 points)
- F. Arm cylinder rod pin (1 point)
- G. Bucket cylinder head pin (1 point)

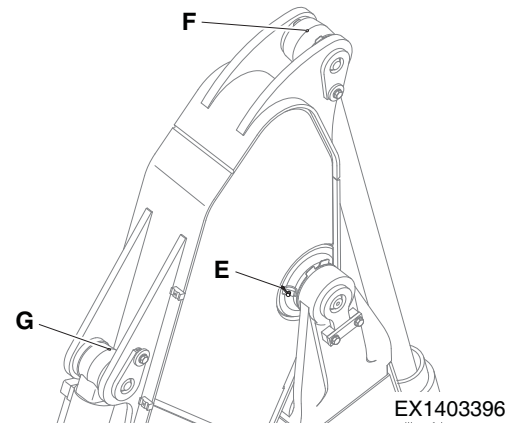
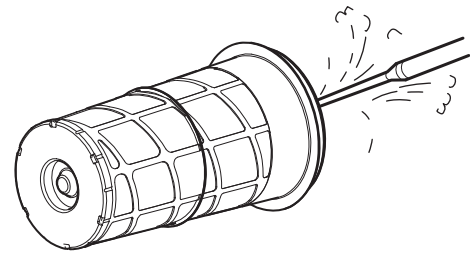

Figure 46

5. Clean the outer filter (4, Figure 64) by blowing compressed air from the inside of the filter towards the outside. Do not use more than 205 kPa (30 psi) air pressure.



EX1404489

**Figure 65**

6. Check outer filter by shining a light through it. If small holes or thinner parts are found on the element after cleaning it, replace the filter.
7. Clean the inside of the air cleaner body and the inside of the air cleaner cover. Do not use compressed air.
8. Properly install the air filter and cover.

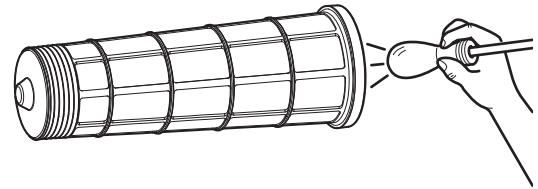

EX1404490

**Figure 66**

9. Install cover (2, Figure 67) as follows.
  - A. Align cover with the element.
  - B. Hook the tip of latches (3, Figure 67) to the protruding part of the air cleaner body and lock it in position.
  - C. When locking latches (3, Figure 67) in position, attach them in turn on opposite sides (top, bottom, left, right) in the same way as when tightening bolts.
  - D. Always install cover (2, Figure 67) so evacuator (1) is facing the ground (A).

**NOTE:** Make sure that lips of evacuator are parallel to cover.

- E. When cover (2, Figure 67) is installed, check that cover (2) is properly seated in air cleaner body. If it is seated, install again.

**NOTE:** If after cleaning the outer filter, the air cleaner clogged indicator remains "ON", replace the outer and inner filters. Do not clean inner filter.

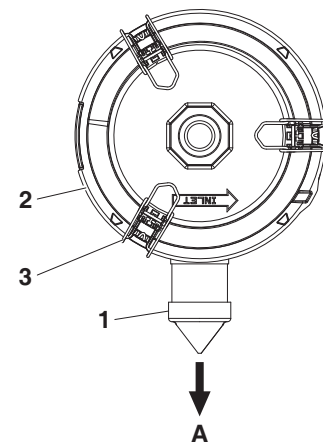

EX1404491

**Figure 67**

## Change Air-conditioning Inner Filter



**AVOID DEATH OR SERIOUS INJURY**

All service and inspection of air-conditioning system must be performed with the starter switch in the "O" (OFF) position.

1. Remove cover by pulling knob outward on top of the left and right of the filter which is inside the left rear part of the cabin.
2. Remove inner filter by pulling knob outward while pressing the upperpart and lower part of the filter handle.
3. Replace with new one.
4. Reassemble filter in reverse order.

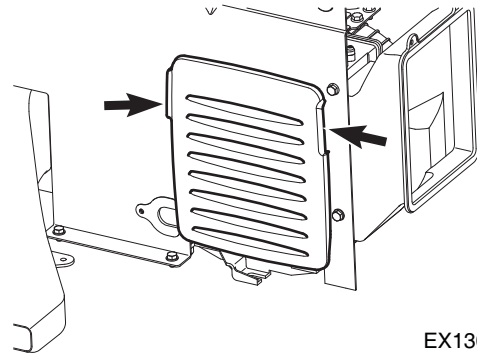

**Figure 88**

EX1300822

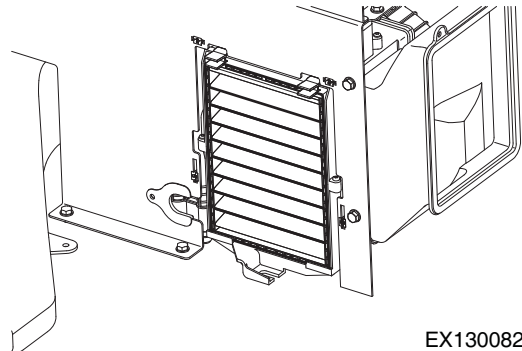

**Figure 89**

EX1300823

# Hydraulic Oil Exchange and Suction Strainer Cleaning

---

## WARNING

---

### AVOID DEATH OR SERIOUS INJURY

The hydraulic oil will be hot after machine operation. Allow the system to cool before attempting to service any of the hydraulic components.

The hydraulic tank is pressurized. Tip breather cap up to allow the pressurized air to vent. After the pressure has been released, remove service covers.

---

## IMPORTANT

---

Make sure to clean any dirt or water from the top of the hydraulic tank, especially around the fill port and filter ports.

Hydraulic oil change interval is 2,000 hours only when Bobcat Genuine Oil is used. If another brand of oil is used, a change interval of 1,000 hours is necessary.

---

**NOTE:** *Based on the type of excavating being completed, the working conditions (extremely hot or dusty) and the extra front end attachments being used (hydraulic breaker, etc.), the hydraulic fluid will need to be changed more frequently.*

1. Park machine on firm and level ground. Swing upper structure parallel to tracks. Lower boom and position bucket on ground as shown in Figure 113.
2. Move safety lever to "LOCK" position.
3. Stop engine.
4. Release pressurized air from hydraulic tank by tip breather cap up (1, Figure 116).



ARO1760L

Figure 112

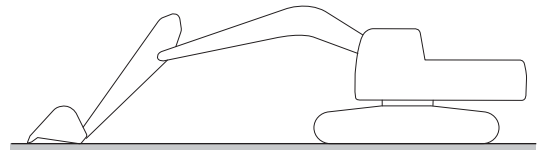

EX1300542

Figure 113

## Fuse Identification

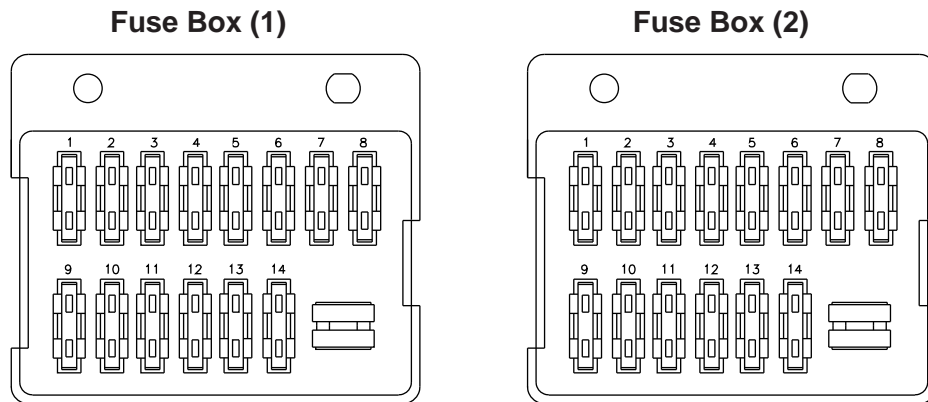

FG000542

Figure 128

No.	Fuse Box One	
	Name	Capacity
1	Cigarette Lighter	10A
2	Rotating Beacon (Optional)	10A
3	Lower Wiper (Optional)	10A
4	12V Power (Optional), Wiper Controller, Window Washer	20A
5	Air Compressor (Optional)	20A
6	Stereo, 12V Power	15A
7	Diesel Heater (Optional)	10A
8	Starter Switch, Hour Meter	30A
9	Air Conditioner, Heater	30A
10	Micro Phone (Optional)	20A
11	EPOS, TMS	15A
12	Seat Warmer, Air Suspension	15A
13	DCU	30A
14	ECU	30A

No.	Fuse Box Two	
	Name	Capacity
1	Horn, Alarm Buzzer (Optional)	15A
2	Glow Plug	30A
3	Auxiliary Mode, Diesel Heater Timer (Optional)	10A
4	Quick Coupler (Optional), Boom Float (Optional), Pedal Safety (Optional)	10A
5	Pilot Cut Off, Headlight, Rear Working Light	15A
6	Fuel Lift Pump	15A
7	Memory Back up	10A
8	Room Light	10A
9	Cabin Light (Optional)	15A
10	Working Light	15A
11	Fuel Heater 1 (Optional)	30A
12	Fuel Heater 2 (Optional)	30A
13	Gauge Panel, Pilot Buzzer, Pressure Sensor	10A
14	Wiper Motor, Fuel Pump (Optional)	15A

# MAINTENANCE IN SPECIAL CONDITIONS

Conditions	Maintenance Required
Operating in mud, water or rain.	Perform a walk around inspection to check for any loose fittings, obvious damage to the machine or any fluid leakage.
	After completing operations, clean mud, rocks or debris from the machine. Inspect for damage, cracked welds or loosened parts.
	Perform all daily lubrication and service.
	If the operations were in salt water or other corrosive materials, make sure to flush the affected equipment with fresh water and check that all control systems operate properly.
Operating in an extremely dusty or hot environment.	Clean the air intake filters on a more frequent basis.
	Clean the radiator and oil cooler fins to remove embedded dirt and dust.
	Clean the fuel system intake strainer and fuel filter more frequently.
	Inspect and clean as required the starter and alternator.
Operating in rocky terrain.	Check the undercarriage and track assemblies for damage or excessive wear.
	Inspect for loose or damaged fittings or bolts.
	Relax track tension.
	On a more frequent basis, inspect the front end attachments for damage or excessive wear.
	Install a top guard and front guard as required for protection against falling rock.
Operating in extreme cold.	Use the proper fuel for the temperature conditions.
	Using a hydrometer, check the antifreeze to make sure that it is providing the proper cold weather freeze protection.
	Verify the condition of the batteries. In extreme cold weather, remove batteries at night and store them in a warmer area.
	Remove mud buildup as soon as possible to prevent it from freezing to the undercarriage and causing damage.

# DISASSEMBLED PARTS, DIMENSION AND WEIGHT

## Components

### Boom

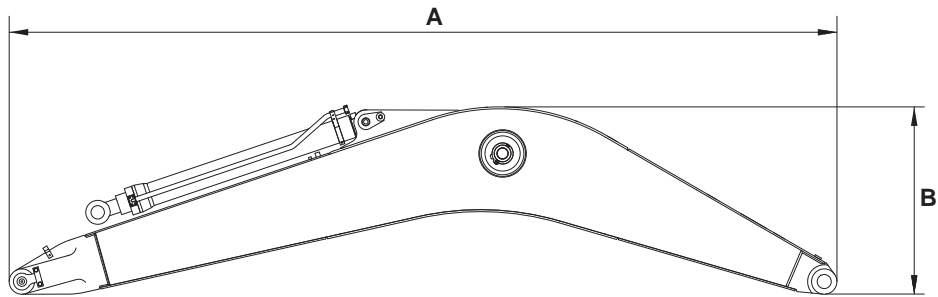

FG019640

Figure 2

Description		5.1 m (16' 9")
Length (A)	mm (ft in)	5,290 (17' 4")
Length (B)		1,300 (4' 3")
Width		675 (2' 3")
Weight	kg	930
	lb	2,050

# APPROXIMATE WEIGHT OF WORKLOAD MATERIALS

## IMPORTANT

Weights are approximations of estimated average volume and mass. Exposure to rain, snow or groundwater; settling or compaction because of overhead weight and chemical or industrial processing or changes because of thermal or chemical transformations could all increase value of weights listed in table.

Material	Density 1,200 kg/m <sup>3</sup> (2,000 lb/yd <sup>3</sup> ), or less	Density 1,500 kg/m <sup>3</sup> (2,500 lb/yd <sup>3</sup> ), or less	Density 1,800 kg/m <sup>3</sup> (3,000 lb/yd <sup>3</sup> ), or less	Density 2,100 kg/m <sup>3</sup> (3,500 lb/yd <sup>3</sup> ), or less
Charcoal	401 kg/m <sup>3</sup> (695 lb/yd <sup>3</sup> )	-	-	-
Coke, blast furnace size	433 kg/m <sup>3</sup> (729 lb/yd <sup>3</sup> )	-	-	-
Coke, foundry size	449 kg/m <sup>3</sup> (756 lb/yd <sup>3</sup> )	-	-	-
Coal, bituminous slack, piled	801 kg/m <sup>3</sup> (1,350 lb/yd <sup>3</sup> )	-	-	-
Coal, bituminous r. of m., piled	881 kg/m <sup>3</sup> (1,485 lb/yd <sup>3</sup> )	-	-	-
Coal, anthracite	897 kg/m <sup>3</sup> (1,512 lb/yd <sup>3</sup> )	-	-	-
Clay, DRY, in broken lumps	1,009 kg/m <sup>3</sup> (1,701 lb/yd <sup>3</sup> )	-	-	-
Clay, DAMP, natural bed	-	-	1,746 kg/m <sup>3</sup> (2,943 lb/yd <sup>3</sup> )	-
Cement, portland, DRY granular	-	-	1,506 kg/m <sup>3</sup> (2,583 lb/yd <sup>3</sup> )	-
Cement, portland, DRY clinkers	-	1,362 kg/m <sup>3</sup> (2,295 lb/yd <sup>3</sup> )	-	-
Dolomite, crushed	-	-	1,522 kg/m <sup>3</sup> (2,565 lb/yd <sup>3</sup> )	-
Earth, loamy, DRY, loose	-	1,202 kg/m <sup>3</sup> (2,025 lb/yd <sup>3</sup> )	-	-
Earth, DRY, packed	-	-	1,522 kg/m <sup>3</sup> (2,565 lb/yd <sup>3</sup> )	-
Earth, WET, muddy	-	-	1,762 kg/m <sup>3</sup> (2,970 lb/yd <sup>3</sup> )	-
Gypsum, calcined, (heated, powder)	961 kg/m <sup>3</sup> (1,620 lb/yd <sup>3</sup> )	-	-	-

CLICK HERE TO **DOWNLOAD** THE COMPLETE MANUAL

- Thank you very much for reading the preview of the manual.
- You can download the complete manual from: [www.heydownloads.com](http://www.heydownloads.com) by clicking the link below



- Please note: If there is no response to CLICKING the link, please download this PDF first and then click on it.

CLICK HERE TO **DOWNLOAD** THE COMPLETE MANUAL