



Bobcat®

AU

NZ

Operation & Maintenance Manual CT225 Compact Tractor

S/N ABFJ11001 & Above

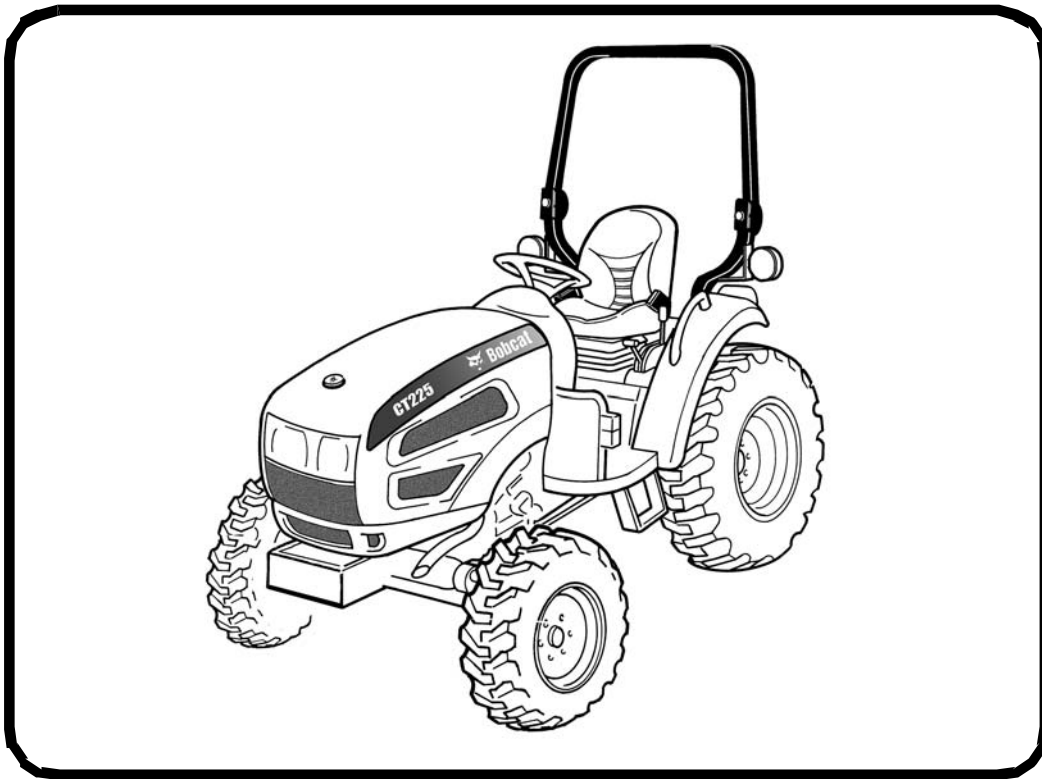

CLICK HERE TO **DOWNLOAD** THE COMPLETE MANUAL

- Thank you very much for reading the preview of the manual.
- You can download the complete manual from: www.heydownloads.com by clicking the link below



- Please note: If there is no response to CLICKING the link, please download this PDF first and then click on it.

CLICK HERE TO **DOWNLOAD** THE COMPLETE MANUAL

SERIAL NUMBER LOCATIONS (CONT'D)

Loader Serial Number (Optional)

Figure 4

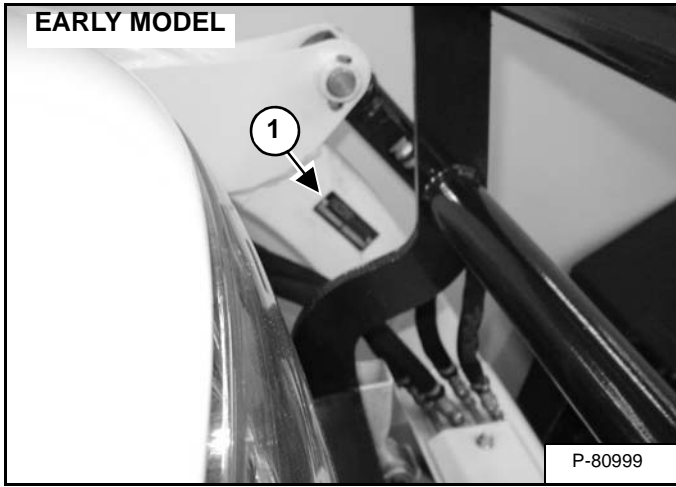
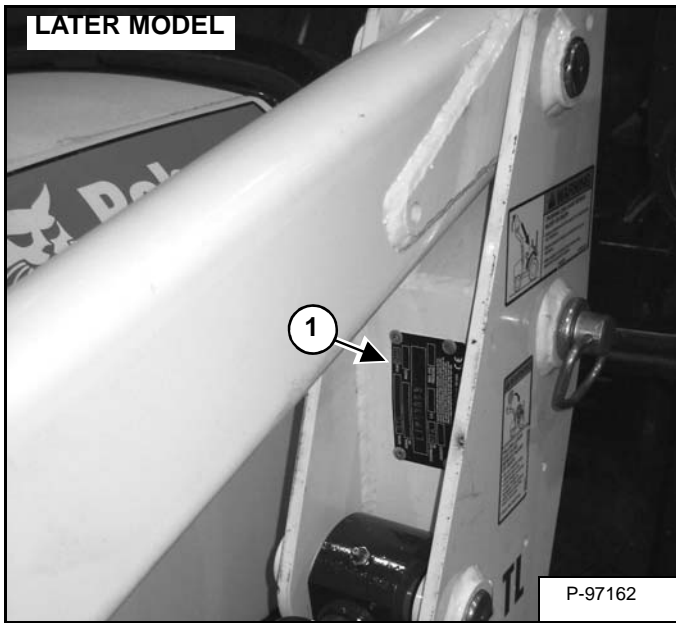

Figure 5



The loader serial number is located on the left loader arm (Item 1) [Figure 4] (early models) or on the left loader upright (Item 1) [Figure 5] (later models).

DELIVERY REPORT

Figure 6

DELIVERY REPORT

WARNING

B-16315

The image shows a form titled 'DELIVERY REPORT'. The form is divided into several sections. At the top right, there is a section labeled 'DELIVERY REPORT' with several lines of text. Below this, there is a section labeled 'WARNING' with a black background and white text. The rest of the form consists of multiple lines of text for recording information. In the bottom right corner, there is a small box containing the number 'B-16315'.

The delivery report [Figure 6] must be completed by the dealer and signed by the owner or operator when the Bobcat compact tractor and / or loader is delivered. An explanation of the form must be given to the owner.

SAFETY INSTRUCTIONS (CONT'D)

Use Safety Rules

- Read and follow instructions in the machine and the attachment's / implement's Operation & Maintenance Manual before operating.
- Check for underground lines before operating attachment / implement (if applicable).
- In addition to the design and configuration of equipment, hazard control and accident prevention are dependent upon the awareness, concern, prudence and proper training of personnel involved in the operation, transport, maintenance and storage of equipment.
- Check that the attachment mounting pins and hardware are installed correctly and securely fastened (if equipped).
- Check that the loader is securely installed to the compact tractor using the correct pins and hardware.
- Check that the Bob-Tach levers are in the locked position and the wedges are fully engaged into the mounting holes of the attachment (if applicable).
- Check that the implement is securely fastened to the machine.
- Depress brake pedals (or make sure parking brake is engaged) and make sure all the machine controls are in the NEUTRAL position before starting the machine.
- Always start the machine from the operator's seat.
- Operate the attachment / implement according to the Operation & Maintenance Manual.
- When learning to operate the attachment / implement, do it at a slow rate in an area clear of bystanders.
- DO NOT permit personnel to be in the work area when operating the machine and attachment / implement.
- The attachment / implement must be used ONLY on approved machines. See your Bobcat dealer for updated list of approved attachments / implements for each machine model.
- DO NOT modify equipment or add attachments / implements that exceed manufacturer's specifications.
- DO NOT make any adjustments or repairs on the machine or attachment / implement while the engine is running.
- Keep shields and guards in place. Replace if damaged.

Avoid Silica Dust



Cutting or drilling concrete containing sand or rock containing quartz may result in exposure to silica dust. Do not exceed Permissible Exposure Limits (PEL) to silica dust as determined by OSHA or other job site Rules and Regulations. Use a respirator, water spray or other means to control dust. Silica dust can cause lung disease and is known to the state of California to cause cancer.

MONITORING THE INSTRUMENT PANEL	60
Procedure	60
STOPPING THE COMPACT TRACTOR	61
Procedure	61
ATTACHMENTS	62
Choosing The Correct Bucket	62
Pallet Forks	62
Choosing The Correct Bucket	63
Installing And Removing The Attachment (Pin-On)	64
Ballast	65
Tires	65
Installing And Removing The Attachment (Bob-Tach)	67
Ballast	69
Tires	69
IMPLEMENT	71
Choosing The Correct Implement	71
Installing And Removing Pull Type Implements	72
Installing And Removing Three-Point Hitch Mounted Implements	76
Lifting Link Adjustment	81
Top Link Adjustment	81
Sway Bar Adjustment	82
Extendable Lower Link Adjustment	82
POWER TAKE-OFF (PTO)	83
Installing And Removing The Rear-PTO	83
Installing And Removing The Mid-PTO	86
BALLAST (OPTIONAL)	88
Front Ballast	88
Rear Ballast	89
TREAD WIDTH	90
Front	90
Rear	90
Tread Width Chart	90

BRAKE PEDALS

Operation

! WARNING

AVOID INJURY OR DEATH

Brake pedals must be locked together before activating the parking brake of the compact tractor. Using unlocked brake pedals to stop the machine at high travel speeds may cause accidental turning or tipping. Slow down before making a turn. Inspect and adjust brakes as needed.

W-2550-0608

Figure 19

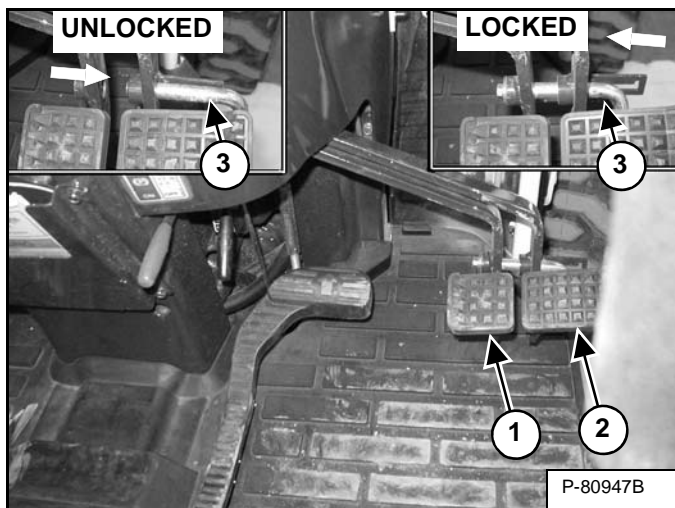

NOTE: It is recommended to keep the left and right brake pedals locked together during operation. Only unlock the brake pedals when adjusting the brakes

With the left and right brake pedals (Item 1 and 2) in the disengaged position, move the pedal lock (Item 3) [Figure 19] to the locked position with the retainer bolt installed. (Both pedals will now move together as one pedal.)

To stop compact tractor movement, press down fully on the brake pedals (Item 1 and 2) [Figure 19].

With brake pedals locked, the compact tractor should stop in a straight line. If compact tractor pulls to one side, brake adjustment is needed. (See BRAKE SYSTEM on Page 138.)

NOTE: Brakes must be adjusted if the brake pedals can be pressed down more than the allowable limit or when the compact tractor pulls to one side when stopping. (See BRAKE SYSTEM on Page 138.)

! WARNING

AVOID INJURY OR DEATH

- Steering and braking can be affected by the loader attachment, implements, front wheel assist and the rear differential lock. Always install the correct ballast. Do not exceed the Loader or Three-Point Hitch lift capacities.
- Always carry loads low. Slow down when turning.
- Always lock brake pedals together for road travel.
- Make sure that the brakes are adjusted correctly so the compact tractor does not pull to one side when braking.

W-2558-0908

REAR AUXILIARY HYDRAULICS (IF EQUIPPED)

Description

The rear (remote) auxiliary hydraulics are used for engaging various functions of rear mounted implements.

The CT225 compact tractor can be equipped with two pairs of rear auxiliary couplers.

IMPORTANT

Always move rear auxiliary hydraulic lever(s) out of detent position before stopping the engine or when no implement is connected.

- Lever(s) left in detent will make starting the engine difficult.
- Lever(s) left in detent with no implement connected will cause the hydraulic fluid to overheat and may damage the system.

I-2279-1008

Rear (Remote) Auxiliary Hydraulics Operation

! WARNING

AVOID BURNS

Hydraulic fluid, tubes, fittings and quick couplers can get hot when running machine and attachments. Be careful when connecting and disconnecting quick couplers.

W-2220-0396

Figure 35

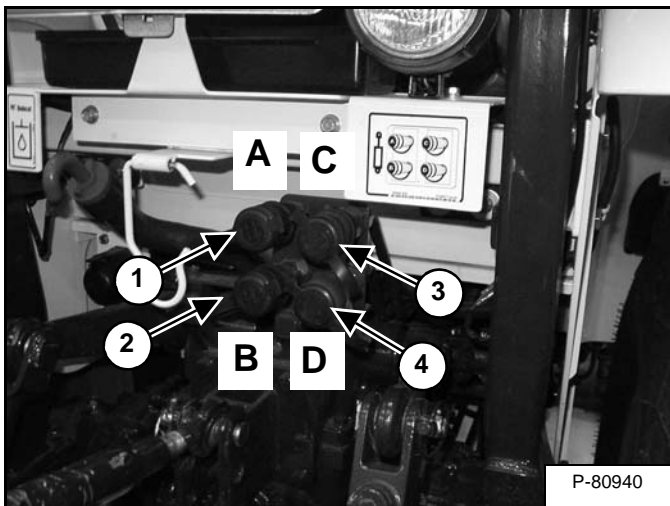

Rear auxiliary hydraulics couplers (Item 1, 2, 3 and 4) [Figure 35] are optional equipment.

Figure 36

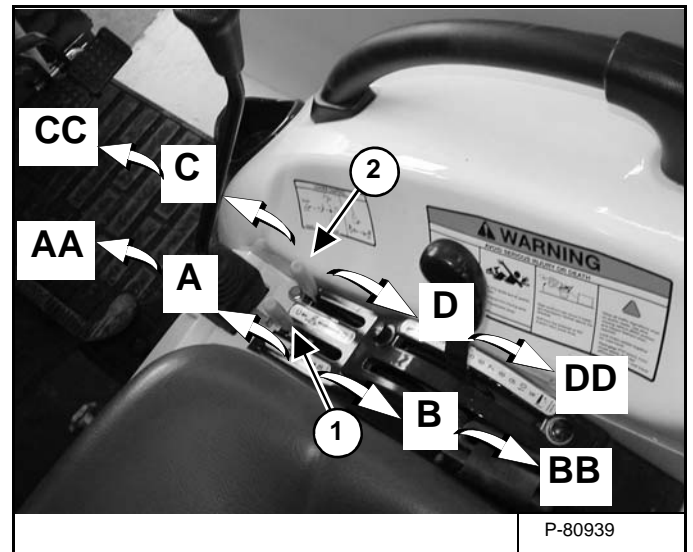

Move the lever (Item 1) [Figure 36] forward to supply hydraulic oil to coupler (A) [Figure 35]. Move the lever (Item 1) [Figure 36] completely forward into the detent position (AA) [Figure 36] to supply continuous hydraulic flow to coupler (A) [Figure 35].

Move the lever backward to remove from detent.

Move the lever (Item 1) [Figure 36] backward to supply hydraulic oil to coupler (B) [Figure 35]. Move the lever (Item 1) [Figure 36] completely backward into the detent position (BB) [Figure 36] to supply continuous hydraulic flow to coupler (B) [Figure 35]. Move the lever forward to remove from detent. (Detent is only available for couplers A and B [Figure 35].)

Move lever (Item 2) [Figure 36] forward to supply hydraulic flow to coupler (C) [Figure 35]. There is no detent function for the (C) [Figure 35] coupler.

Move lever (Item 2) [Figure 36] backward to supply hydraulic flow to coupler (D) [Figure 35]. There is no detent function for the (D) [Figure 35] coupler.

Function Chart

LEVER 1		PUSH FORWARD	PULL BACK
PORT	A	PRESSURE	RETURN
	B	RETURN	PRESSURE
	C	PRESSURE	RETURN
	D	RETURN	PRESSURE

STARTING THE ENGINE

Key Switch



AVOID DEATH

Do not attempt to start the engine by shorting across the starter terminals.

Always start the machine from the operator's seat only.

D-1001-0907



Figure 53



Set the engine speed control (Item 1) [Figure 53] to the 1/2 speed position.

Turn the key (Item 2) [Figure 53] to the ON position.

If the glow plug icon (Item 3) [Figure 53] is ON, wait for it to go OFF.

NOTE; The glow plugs can be manually activated by turning the key to the PRE-HEAT position. Pre-Heat for 60 seconds MAXIMUM.

(See Cold Temperature Starting on Page 60.)

Turn the key to START position [Figure 53] and release it when the engine starts. The key will return to the ON position [Figure 53]. (See Safety Interlock System (Neutral Start) on Page 34.)

(The glow plug light may illuminate after starting the engine.)

Move the engine speed control lever forward to increase the engine speed.

Stop the engine if the warning lights stay ON after the engine is running.

Pull the engine speed control fully backward and turn the key switch OFF [Figure 53] to stop the engine.



AVOID INJURY OR DEATH

When an engine is running in an enclosed area, fresh air must be added to avoid concentration of exhaust fumes. If the engine is stationary, vent the exhaust outside. Exhaust fumes contain odorless, invisible gases which can kill without warning.

W-2050-0807



AVOID INJURY OR DEATH

- Use ROPS and fasten seat belt.
- Start and operate only from the operator's seat.
- Never wear loose clothing when working near machine.

W-2673-0907

ATTACHMENTS (CONT'D)

Installing And Removing The Attachment (Bob-Tach) (Cont'd)

Installing (Cont'd)

! WARNING

AVOID INJURY OR DEATH

The Bob-Tach wedges must extend through the holes in the attachment mounting frame. Levers must be fully down and locked. Failure to secure wedges can allow attachment to come off.

W-2715-0208

Figure 69

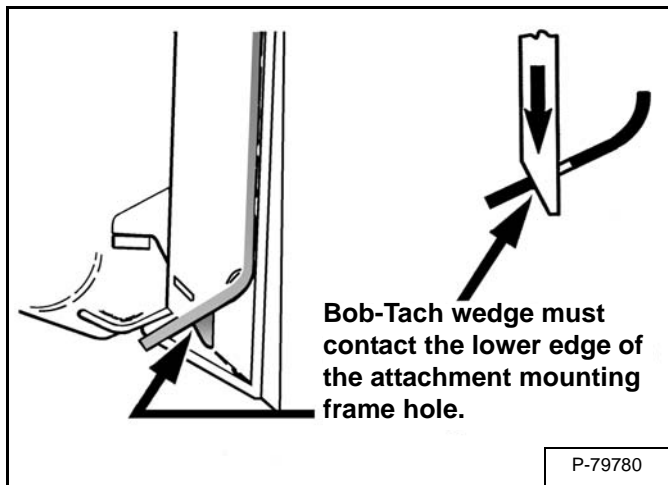

The wedges must extend through the holes in the mounting frame of the attachment, securely fastening the attachment to the Bob-Tach [Figure 69].

Connect the auxiliary hydraulic hoses (if applicable).

Figure 70

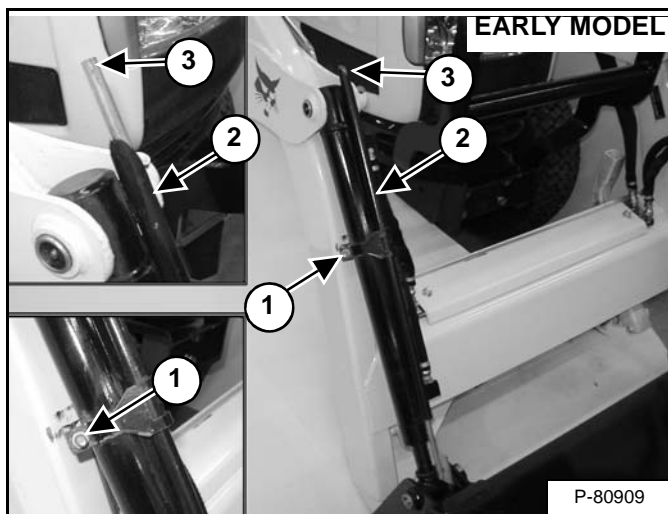

For Early Model: Loosen the level indicator slide bracket bolt (Item 1) located on the right tilt cylinder. Adjust level indicator slide bracket (Item 2) so that the end of the rod is flush (Item 3) with the end of the slide bracket. Tighten slide bracket bolt (Item 1) [Figure 70].

Figure 71

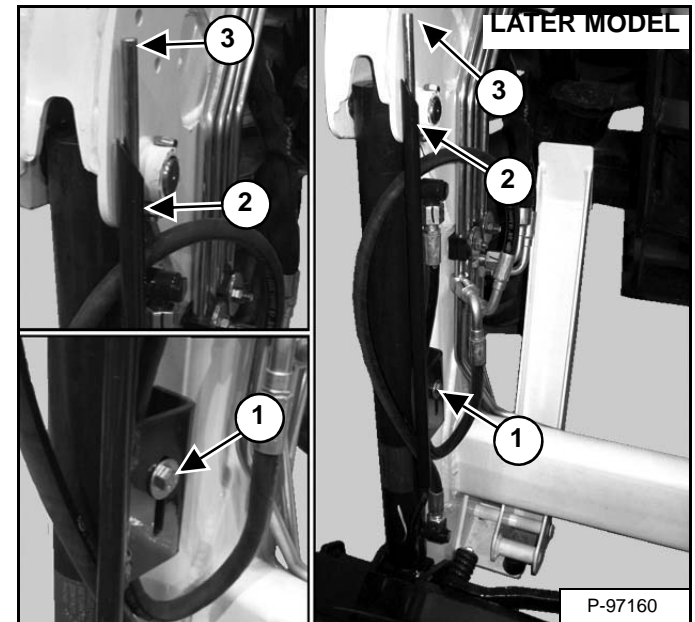

For Later Model: Loosen the level indicator clamp bolt (Item 1) located on the right tilt cylinder. Adjust level indicator slide bracket (Item 2) so that the end of the rod is flush (Item 3) with the end of the slide bracket. Tighten clamp bolt (Item 1) [Figure 71].

Ballast

Ballast will need to be added to the rear of the compact tractor for proper loader operation. (See Ballast (Rear) on Page 211.) and (See Compact Tractor Loader Lift Capacity on Page 211.)

Tires

Tires with the correct load rating will need to be installed on the compact tractor for proper loader operation. (See Tires on Page 219.)

IMPLEMENT (CONT'D)

Installing And Removing Three-Point Hitch Mounted Implements (Cont'd)

Removing

Stop the engine and exit the compact tractor. (See STOPPING THE COMPACT TRACTOR on Page 61.)

Make sure the PTO driveline and all rotating components have come to a complete stop before exiting the compact tractor (if applicable).

Block the wheels of the implement to keep it from rolling (if applicable).

WARNING

AVOID INJURY OR DEATH

Before you leave the operator's seat:

- Fully lower the loader arms, put the attachment flat on the ground (if equipped).
- Fully lower the implement(s) to the ground (if equipped).
- Lock brake pedals together and engage the parking brake.
- Place F-N-R lever in neutral (SST models only).
- Place all controls in neutral.
- Stop the engine, unfasten the seat belt and remove the key.

W-2569-0909

Figure 85

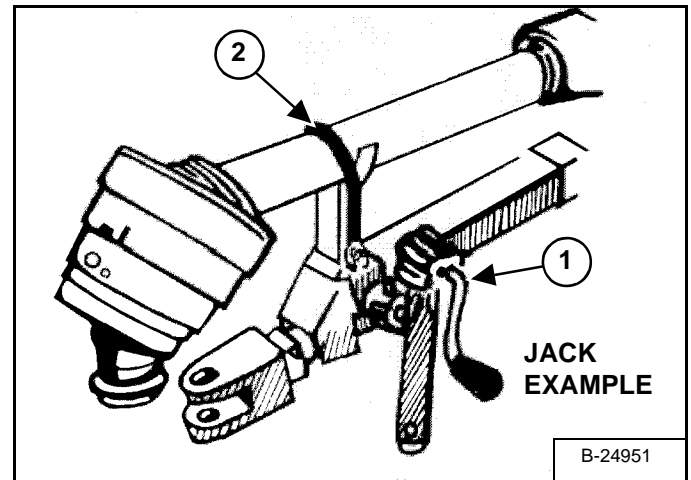

Lower the implement to the ground. Use an approved jack (Item 1) [Figure 85] to support the implement (if equipped) or block the implement. (In freezing conditions, place the implement on blocks or planks to keep the implement from freezing to the ground.)

Disconnect the hydraulic hoses or electrical connections (if applicable). (See REAR AUXILIARY HYDRAULICS (IF EQUIPPED) on Page 49.)

Disconnect the PTO driveline (if applicable) and install the PTO driveline into the storage area (Item 2) [Figure 85] (if equipped). (See Installing And Removing The Rear-PTO on Page 83.)

IMPORTANT

Always move rear auxiliary hydraulic lever(s) out of detent position before stopping the engine or when no implement is connected.

- Lever(s) left in detent will make starting the engine difficult.
- Lever(s) left in detent with no implement connected will cause the hydraulic fluid to overheat and may damage the system.

I-2279-1008

BALLAST (OPTIONAL) (CONT'D)

Rear Ballast

Rear Ballast Box

WARNING

AVOID INJURY OR DEATH

- Steering and braking can be affected by the loader attachment, implements, front wheel assist and the rear differential lock. Always install the correct ballast. Do not exceed the Loader or Three-Point Hitch lift capacities.
- Always carry loads low. Slow down when turning.
- Always lock brake pedals together for road travel.
- Make sure that the brakes are adjusted correctly so the compact tractor does not pull to one side when braking.

W-2558-0908

Figure 102

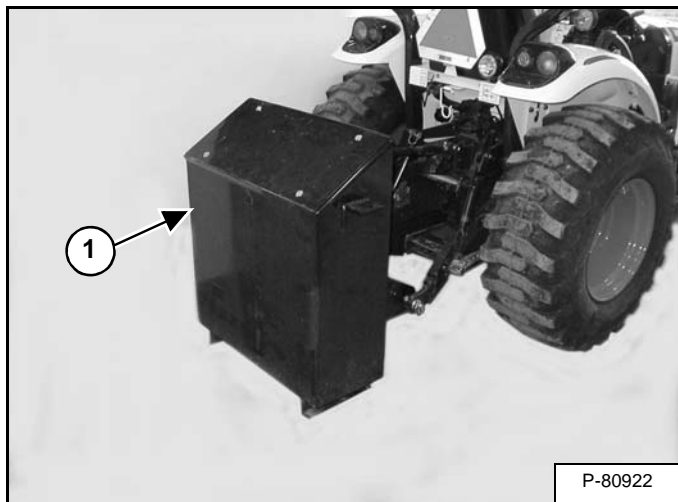

Install the ballast box (Item 1) [Figure 102] to the three-point hitch. (See THREE-POINT HITCH on Page 52.)

Fill the ballast box (Item 1) [Figure 102] with the correct amount of weight. (See Ballast (Rear) on Page 211.)

Rear Liquid Ballast

A solution of water and calcium chloride can be used as a safe and economical ballast in the rear compact tractor tires. Both rear tires must be filled to 75% full if liquid ballast is used.

NOTE: Liquid ballast must be installed by a trained technician. Contact your local tire service store for installing or removing liquid ballast.

A water and calcium chloride mixture of 5.0 lb./Gal. (0,6 kg/liter) will not freeze solid to temperatures above -50° F (-45° C).

With the rear tire valve stem at the 12 o'clock position, fill tubeless tires to the valve stem level (75% full). Tubeless tires filled with less water and calcium chloride mixture would expose part of the rim and possibly cause corrosion. Fill the other rear tire with liquid ballast.

Tube type tires may be filled to any level below 90%.

NOTE: Do NOT add liquid ballast to the front tires.

When using the optional loader, a rear ballast box must also be installed on the compact tractor. (See Rear Ballast on Page 89.) With both rear tires filled to 75% with liquid ballast, the ballast box must be filled with the correct amount of weight. (See Ballast (Rear) on Page 211.)

IMPORTANT

Foam filled tires are NOT approved for use on the Compact Tractor. Axle damage may occur with foam filled tires. Warranty will be voided if foam filled tires are used on this machine.

I-2277-0608

OPERATING PROCEDURE (CONT'D)

Safety Rules For PTO Operation

WARNING

AVOID INJURY OR DEATH

- Do NOT exceed the rated implement PTO speed.
- Stay clear of rotating driveline.
- Keep bystanders away.
- Keep hands, feet, clothing and long hair away.
- Keep PTO shields and all guards in place.
- Disengage PTO (rear and mid), engage the parking brake, stop the engine and make sure all rotating components are stopped before exiting compact tractor.
- If using the compact tractor rear-PTO in a stationary application; install blocks in front of and behind the rear tires and keep away from the PTO driveline when in use. Walk around the equipment, do not step over, lean across or crawl under a rotating driveline.
- Do NOT service the compact tractor or implement with the PTO (rear or mid) engaged.
- Do NOT service the implement in a raised position unless properly blocked and with all rotating components stopped.
- Disengage PTO (rear and mid) for road travel.

W-2579-0907

WARNING

AVOID INJURY OR DEATH

Before you leave the operator's seat:

- Fully lower the loader arms, put the attachment flat on the ground (if equipped).
- Fully lower the implement(s) to the ground (if equipped).
- Lock brake pedals together and engage the parking brake.
- Place F-N-R lever in neutral (SST models only).
- Place all controls in neutral.
- Stop the engine, unfasten the seat belt and remove the key.

W-2569-0909

WARNING

DRIVELINE ENTANGLEMENT OR OVERSPEEDING PTO CAN CAUSE SERIOUS INJURY OR DEATH

- DO NOT install an adapter between the machine PTO shaft and implement PTO driveline.
- An adapter can extend the driveline universal joint and connecting yoke beyond the PTO shields.
- An adapter can overspeed the implement PTO causing driveline or implement damage.

W-2799-0609

WARNING

AVOID INJURY OR DEATH

Warnings and instructions in this manual and on the machine are for your protection.

Failure to follow the warnings and instructions can cause serious injury or death.

W-2621-1104

- Keep all shields in place. Replace damaged or missing shields before operating
- Follow warnings and instructions on machine signs (decals). Replace damaged or missing decals.
- Do not wear loose or bulky clothing around the PTO or other moving parts.
- Keep bystanders away from PTO driven equipment, and never allow children near machines.
- Read and understand the manuals for the PTO driven equipment and be aware of safe operating procedures and hazards that may not be readily apparent.
- Always walk around equipment to avoid coming near a turning PTO driveline. Stepping over, leaning across or crawling under a turning PTO driveline can lead to entanglement.
- Do not install an adapter between the machine PTO shaft and the implement PTO driveline.
- Never overspeed the PTO. See implement Operation and Maintenance Manual for correct PTO speed.
- Position the machine and implement hitch correctly to prevent driveline stress and separation.
- Use caution when turning. Turning too sharp can cause driveline damage.

CLICK HERE TO **DOWNLOAD** THE COMPLETE MANUAL

- Thank you very much for reading the preview of the manual.
- You can download the complete manual from: www.heydownloads.com by clicking the link below



- Please note: If there is no response to CLICKING the link, please download this PDF first and then click on it.

CLICK HERE TO **DOWNLOAD** THE COMPLETE MANUAL

LOADER SYSTEM

LOADER INSTALLATION	111
Description	111
Installing Loader Mounting Brackets	111
LOADER INSTALLATION AND REMOVAL	116
Installing The Loader To The Compact Tractor	116
Ballast	121
Removing The Loader	121

LOADER INSTALLATION AND REMOVAL (CONT'D)

Installing The Loader To The Compact Tractor (Cont'd)

Figure 152

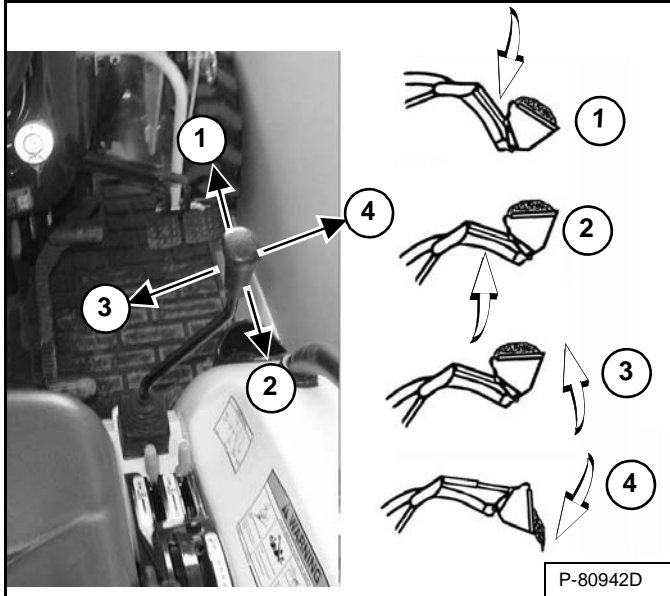
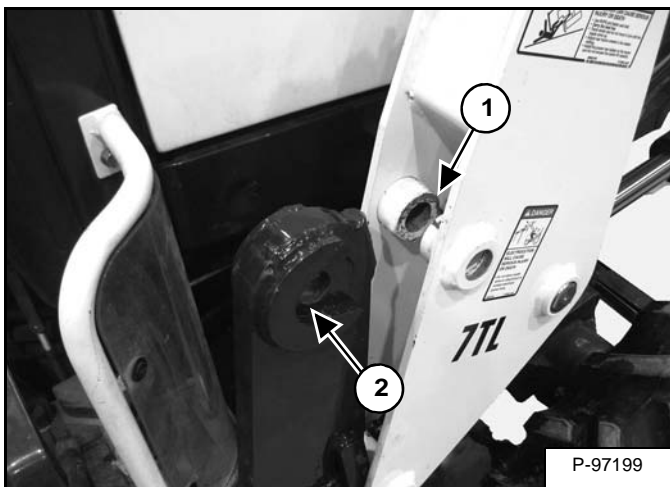

Figure 153



Using the joystick control lever, slowly lower the loader arms [retract the loader arm cylinders] (Item 1) [Figure 152] until the loader arm uprights rotate back and the bushing (Item 1) [Figure 153] contacts the upper retainer (Item 2) [Figure 153] of the mounting brackets (both sides).

Stop the engine and exit the compact tractor. (See STOPPING THE COMPACT TRACTOR on Page 61.)

Figure 154

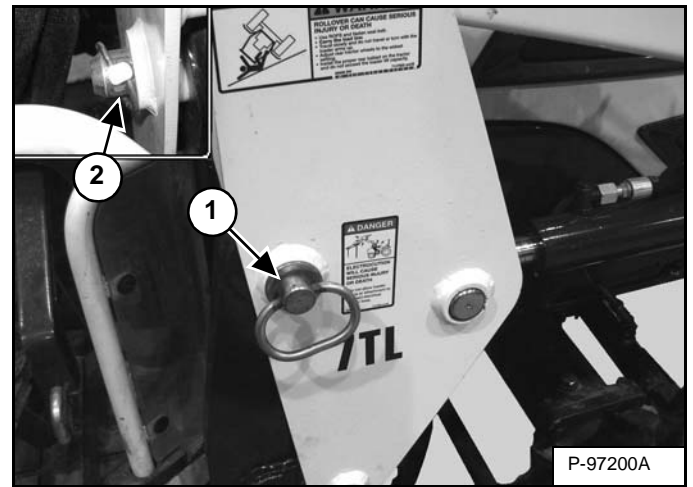

Install the retaining pin (Item 1) and the retainer pin (Item 2) [Figure 154] (both sides) to secure the loader arms to the mounting brackets (both sides).

Perform the pre-starting procedure. (See PRE-STARTING PROCEDURE on Page 57.)

Start the engine and release the parking brake.

Figure 155

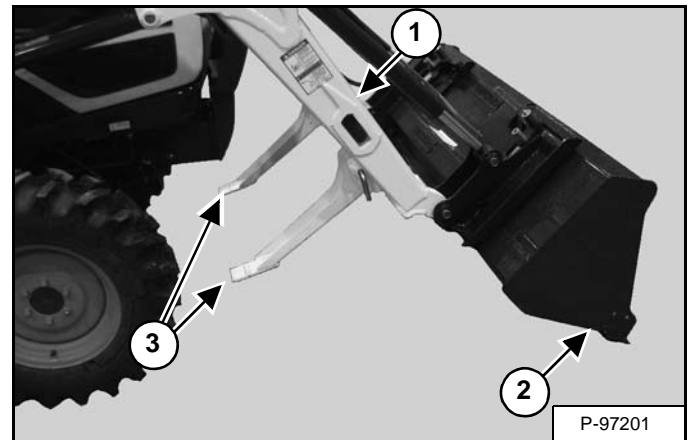

Using the joystick control lever, raise the loader arms (Item 1) and tilt the bucket forward (Item 2) so the loader support stands (Item 3) [Figure 155] are off the ground. Lower the loader arms until the bucket cutting edge is on the ground. (The loader support stands need to be off the ground for repositioning the stands to the storage position.)

Stop the engine and exit the compact tractor. (See STOPPING THE COMPACT TRACTOR on Page 61.)

! WARNING

AVOID INJURY OR DEATH

Always have the bucket cutting edge on the ground before raising or lowering the loader support stands.

W-2585-0707

MAINTENANCE SAFETY



WARNING

Instructions are necessary before operating or servicing machine. Read and understand the Operation & Maintenance Manual, Operator's Handbook and signs (decals) on machine. Follow warnings and instructions in the manuals when making repairs, adjustments or servicing. Check for correct function after adjustments, repairs or service. Untrained operators and failure to follow instructions can cause injury or death. W-2003-0807



Safety Alert Symbol: This symbol with a warning statement, means: "Warning, be alert! Your safety is involved!" Carefully read the message that follows.

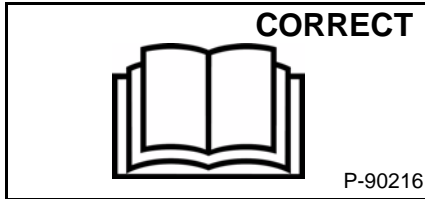

⚠ Never service the machine without instructions.

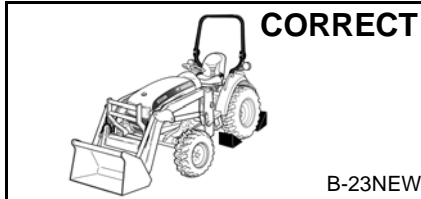

⚠ Before exiting machine, engage parking brake. Chock wheels before servicing

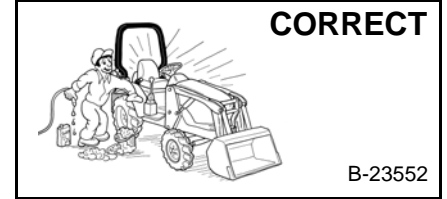

⚠ Cleaning and maintenance are required daily.



⚠ Have good ventilation when welding or grinding painted parts.
 ⚠ Wear dust mask when grinding painted parts. Toxic dust and gas can be produced.
 ⚠ Avoid exhaust fume leaks which can kill without warning. Exhaust system must be tightly sealed.

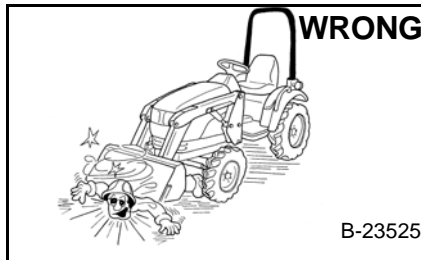

⚠ Disconnecting or loosening any hydraulic tubeline, hose, fitting, component or a part failure can cause loader arms to drop.
 ⚠ Lower loader arms, attachments, and implements (if equipped) before servicing.
 ⚠ DO NOT service the compact tractor or implement with the PTO system engaged.

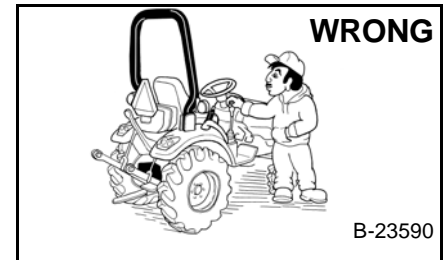

⚠ Never start the machine if not properly seated in the operator's seat.
 ⚠ Never work on the machine with loader arms raised.
 ⚠ Never modify equipment or add attachments not approved by Bobcat Company.

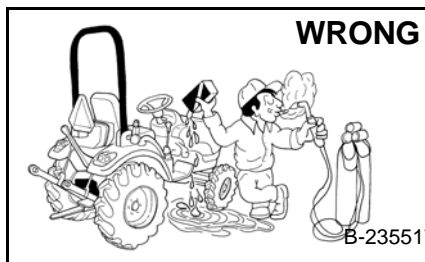

⚠ Stop, cool and clean engine of flammable materials before checking fluids.
 ⚠ Never service or adjust machine with the engine running unless instructed to do so in the manual.
 ⚠ Avoid contact with leaking hydraulic fluid or diesel fuel under pressure. It can penetrate the skin or eyes.
 ⚠ Never fill fuel tank with engine running, while smoking or when near open flame.

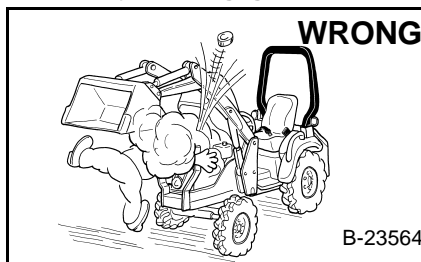

⚠ Keep body, jewelry and clothing away from moving parts, electrical contact, hot parts and exhaust.
 ⚠ Wear eye protection to guard from battery acid, compressed springs, fluids under pressure and flying debris when engines are running or tools are used. Use eye protection approved for type of welding.
 ⚠ Keep engine cover and side access panels closed except for service.

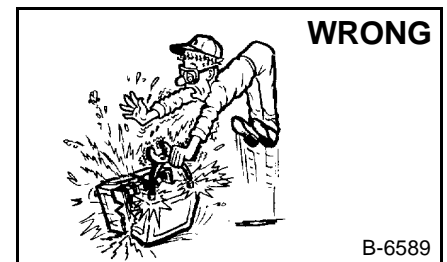

⚠ Lead-acid batteries produce flammable and explosive gases.
 ⚠ Keep arcs, sparks, flames and lighted tobacco away from batteries.
 ⚠ Batteries contain acid which burns eyes or skin on contact. Wear protective clothing. If acid contacts body, flush well with water. For eye contact, flush well and get immediate medical attention.

Maintenance procedures which are given in the Operation & Maintenance Manual can be performed by the owner/operator without any specific technical training. Maintenance procedures which are **not** in the Operation & Maintenance Manual must be performed **ONLY BY QUALIFIED BOBCAT SERVICE PERSONNEL**. Always use genuine Bobcat replacement parts.

MSW32-0409

BRAKE SYSTEM (CONT'D)

Adjusting

Figure 181

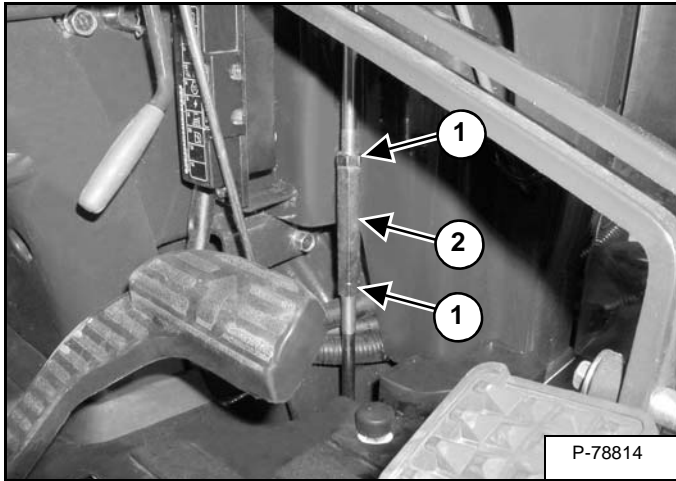

Right Brake Pedal Adjustment

The adjustment linkage for the right brake pedal is located on the right side of the instrument panel.

To adjust the right brake pedal free travel, loosen the two lock nuts (Item 1) [Figure 181].

Turn the turn buckle (Item 2) [Figure 181] to change pedal travel.

When both the left and right pedals have been set to the same free travel, tighten the two lock nuts (Item 1) [Figure 181].

Figure 182

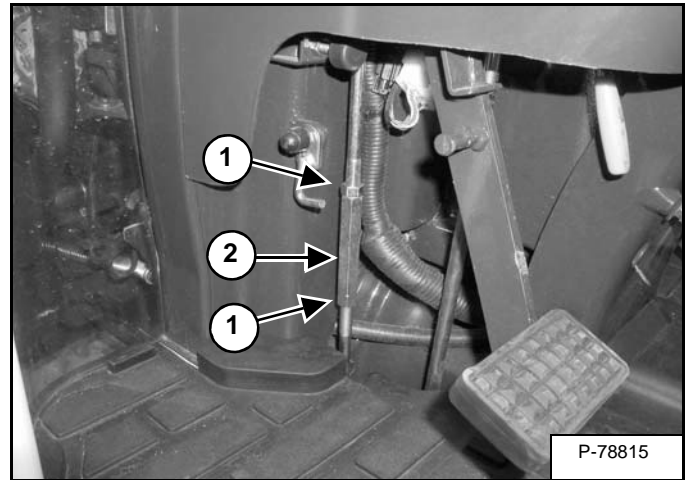

Left Brake Pedal Adjustment

The adjustment linkage for the left brake pedal is located on the left side of the instrument panel.

To adjust the left brake pedal free travel, loosen the two lock nuts (Item 1) [Figure 182].

Turn the turn buckle (Item 2) [Figure 182] to change pedal travel.

When both the left and right pedals have been set to the same free travel, tighten the two lock nuts (Item 1) [Figure 182].

After the brake pedals have been adjusted, the compact tractor should stop in a straight line when using the brake pedals. If compact tractor pulls to one side, readjust the brakes as needed.

After brake pedal inspection or adjustment is completed, lock the brake pedals together. Move the pedal lock (Item 3) to the locked position and install the retaining bolt (Item 2) [Figure 179].

WARNING

AVOID INJURY OR DEATH

Brake pedals must be locked together before activating the parking brake of the compact tractor. Using unlocked brake pedals to stop the machine at high travel speeds may cause accidental turning or tipping. Slow down before making a turn. Inspect and adjust brakes as needed.

W-2550-0608

FUEL SYSTEM

Fuel Specifications

Use only clean, high quality diesel fuel.

At a minimum, Low Sulfur (500 ppm sulfur) Diesel Fuel must be used in this machine.

The following fuels may also be used in this machine:

- Ultra Low Sulfur (15 ppm sulfur) Diesel Fuel.
- Biodiesel Blend Fuel - Must contain no more than five percent biodiesel mixed with low sulfur or ultra low sulfur petroleum based diesel. This is commonly marketed as B5 blended diesel fuel.



AVOID INJURY OR DEATH

Stop and cool the engine before adding fuel. **NO SMOKING!** Failure to obey warnings can cause an explosion or fire.

W-2063-0807



AVOID INJURY OR DEATH

Always clean up spilled fuel or oil. Keep heat, flames, sparks or lighted tobacco away from fuel and oil. Failure to use care around combustibles can cause explosion or fire.

W-2103-0508

Biodiesel Blend Fuel

Biodiesel blend fuel has unique qualities that should be considered before using in this machine:

- Cold weather conditions can lead to plugged fuel system components and hard starting.
- Biodiesel blend fuel is an excellent medium for microbial growth and contamination which can cause corrosion and plugging of fuel system components.
- Use of biodiesel blend fuel may result in premature failure of fuel system components, such as plugged fuel filters and deteriorated fuel lines.
- Shorter maintenance intervals may be required, such as cleaning the fuel system and replacing fuel filters and fuel lines.
- Using biodiesel blended fuels containing more than five percent biodiesel can affect engine life and cause deterioration of hoses, tubelines, injectors, injector pump and seals.

Apply the following guidelines if biodiesel blend fuel is used:

- Ensure the fuel tank is as full as possible at all times to prevent moisture from collecting in the fuel tank.
- Ensure that the fuel tank cap is securely tightened.
- Biodiesel blend fuel can damage painted surfaces, remove all spilled fuel from painted surfaces immediately.
- Drain all water from the fuel filter daily before operating the machine.
- Do not exceed engine oil change interval. Extended oil change intervals can cause engine damage.
- Before vehicle storage; drain the fuel tank, refill with 100% petroleum diesel fuel, add fuel stabilizer and run the engine for at least 30 minutes.

NOTE: Biodiesel blend fuel does not have long term stability and should not be stored for more than three months.

ELECTRICAL SYSTEM (CONT'D)

Fuse And Relay Location (Instrument Panel)

Relays

There are five relays used in the electrical circuit. The relays are located on the engine firewall as on the right side of the battery (as shown below). The flasher unit is located on the left side of the steering column below the dash.

Figure 224

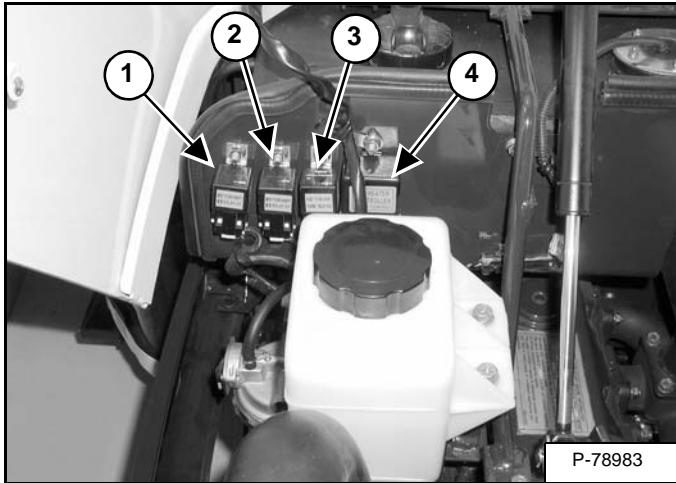

Relay (Item 1) **[Figure 224]** is for the ignition switch.

Relay (Item 2) **[Figure 224]** is for the glow plugs.

Relay (Item 3) **[Figure 224]** is for the fuel pull solenoid.

Timer (Item 4) **[Figure 224]** for the glow plugs.

Figure 225

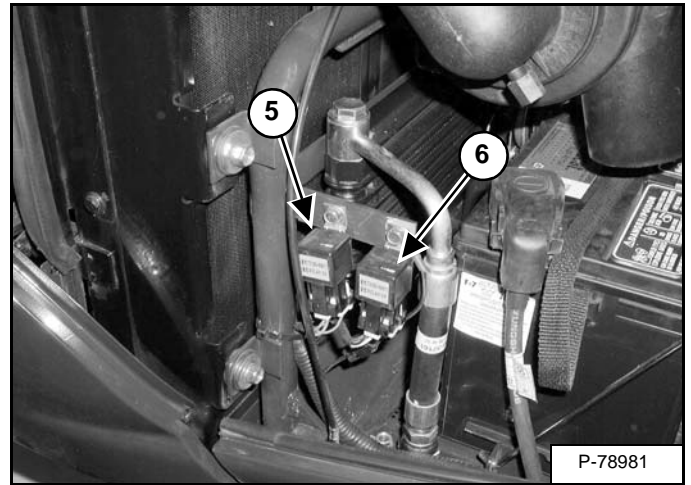

Relay (Item 5) **[Figure 225]** for high beam relay.

Relay (Item 6) **[Figure 225]** for low beam relay.

Figure 226

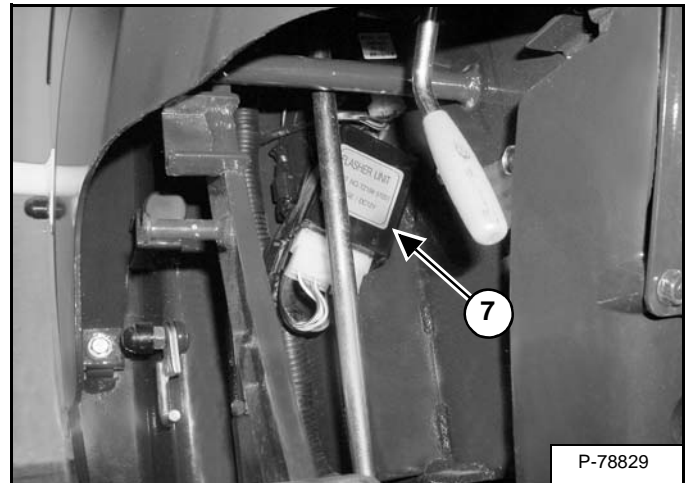

Flasher (Item 7) **[Figure 226]** for the directional signals / hazard / flashers.

TIRE MAINTENANCE

Front Wheel Nuts / Bolts

Check the wheel nut / bolt torque at the correct service interval (See SERVICE SCHEDULE on Page 131.)

Front Wheels: The correct bolt torque is 62 ft.-lb. (83 N•m).

Front Wheels: The correct nut torque is 50 ft.-lb. (68 N•m).

Rear Wheel Nuts / Bolts

Rear Wheels: The correct nut or bolt torque is 160 ft.-lb. (215 N•m).

Check the tires regularly for wear, damage and pressure.

Use tires with the correct load rating for proper loader operation. (See Tires on Page 219.)

IMPORTANT

Never use tire sizes which are not approved by Bobcat Company. Excessive tire wear or transmission damage could occur.

I-2270-1209

Mounting

Check the tires regularly for wear, damage and pressure.

WARNING

AVOID INJURY OR DEATH

- **Do Not attempt to mount a tire on the rim. This must be done by qualified personnel with the proper equipment.**
- **Always maintain the correct tire pressure. Do not inflate the tires above the recommended pressures shown in the Operation & Maintenance Manual.**
- **Use tires with the correct load rating for proper loader operation.**

W-2598-1209

Tires are to be repaired only by an authorized person using the proper procedures and safe equipment.

Tires and rims must always be checked for correct size before mounting. Check rim and tire bead for damage.

The rim flange must be cleaned and free of rust.

The tire bead and rim flange must be lubricated with a rubber lubricant before mounting the tire.

Avoid excessive pressure which can rupture the tire and cause serious injury or death.

During inflation of the tire, check the tire pressure frequently to avoid over inflation.

WARNING

AVOID INJURY OR DEATH

Do not inflate tires above specified pressure. Failure to use correct tire mounting procedure can cause an explosion which can result in injury or death.

W-2078-1007

AXLE TOE IN

Inspection And Maintenance

Figure 267

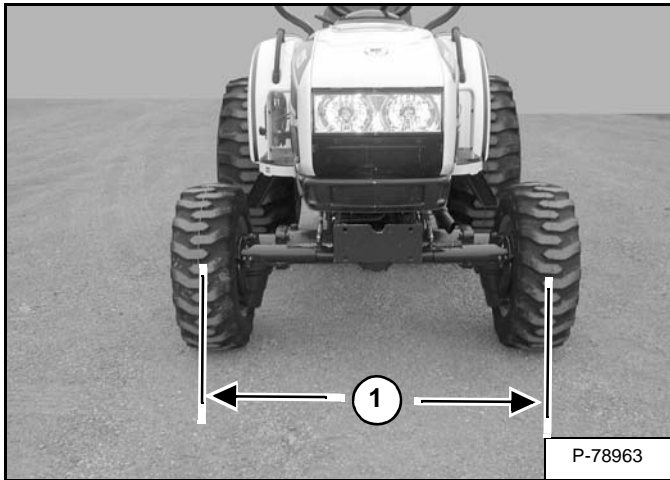
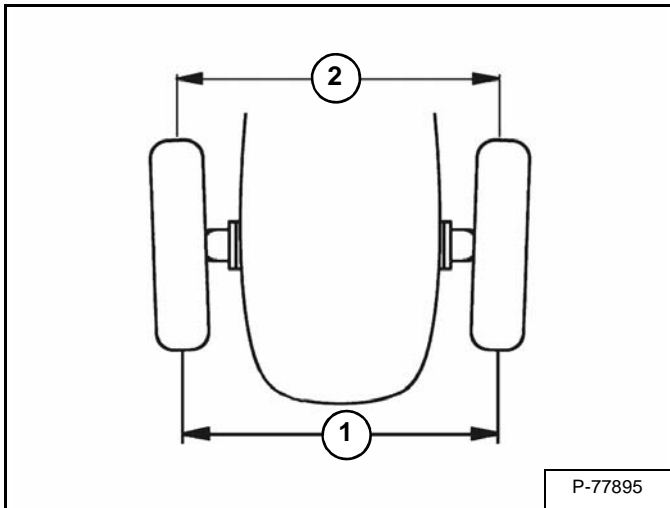

Figure 268



Stop the engine and exit the compact tractor. (See STOPPING THE COMPACT TRACTOR on Page 61.)

The front axle toe in will need to be measured at the centerline of the front tires, both on the front side (Item 1) [Figure 267] and rear side (Item 2) [Figure 268] of the front axle.

Measure the front centerline of the front tires (Item 1) [Figure 267] and [Figure 268] and write this dimension down.

Measure the rear centerline of the front tires (Item 2) [Figure 268] and write this dimension down.

The front dimension (Item 1) [Figure 267] and [Figure 268] should be 0.08 - 0.31 in. (2 - 8 mm) less than the rear dimension (Item 2) [Figure 268].

Figure 269

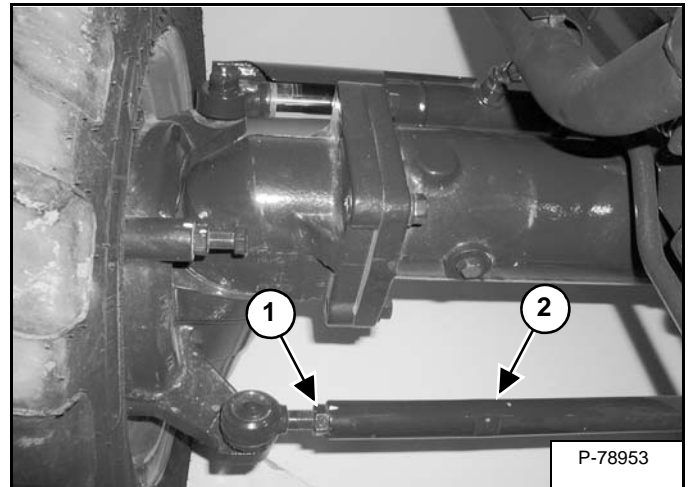

If the dimension is not correct, loosen the tie rod lock nut (Item 1) (both sides) and install a wrench on the flat area (Item 2) [Figure 269] on the tie rod. Turn the tie rod to adjust the toe in until the correct measurement is obtained.

Measure the toe in dimension again after the tie rod has been adjusted. Readjust as necessary.

Tighten the lock nut (Item 1) [Figure 269] (both sides).

⚠ ADVERTENCIA

EVITE LESIONES SERIAS O LA MUERTE

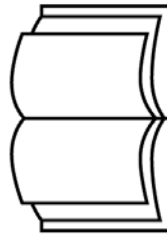

Nunca use el tractor compacto sin haber leído las instrucciones.
 Lea el Manual de operación y mantenimiento y la Guía del operador.
 Nunca modifique el equipo ni use accesorios e implementos no aprobados por Bobcat Company.

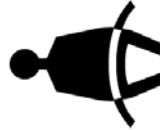

Ajústese el cinturón de seguridad en forma segura cuando la estructura protectora de vuelcos (ROPS) está levantada y bloqueada.
NO use el cinturón de seguridad si la ROPS está baja.



Estacione el tractor compacto sobre un terreno horizontal.
 Bloquee los pedales de freno juntos y active el freno de estacionamiento antes de abandonar el tractor compacto.

ABANDONO DEL TRACTOR COMPACTO:

1. Baje todos los accesorios e implementos hasta el nivel del suelo.
2. Bloquee los pedales de freno juntos y active el freno de estacionamiento.
3. Coloque todos los controles en punto muerto.
4. Detenga el motor y retire la llave.

Weitere Anweisungen finden sie in der Bedienung - und Instandhaltungsanleitung.
 Para más instrucciones, vea el Manual de operación y mantenimiento.
 Voir le Manuel de l'opérateur et d'entretien pour d'autres renseignements.

70564 SW 7118012A ar



MACHINE SIGN TRANSLATIONS (CONT'D)

Warning (7157924)

⚠ WARNING



- Hot surfaces can cause serious injury.
- Do not touch.
- Allow to cool before servicing.



Keep fingers and objects away from fan.

71634 SW 7157924 enUS

⚠ ADVERTENCIA



- Las superficies calientes pueden provocar lesiones graves.
- No las toque.
- Permita que se enfríen antes de dar servicio.



Mantenga los dedos y objetos alejados del ventilador.

71634 SW 7157924 ar

⚠ AVERTISSEMENT



- Les surfaces brûlantes peuvent provoquer des blessures graves.
- Ne touchez pas ces surfaces.
- Laissez-les refroidir avant tout entretien.



Gardez les doigts et les objets à distance du ventilateur.

71634 SW 7157924 fr

Warning (7125076)

⚠ WARNING

AVOID INJURY OR DEATH

- Check that seat switch is properly installed and functions correctly.
- Replace switch and components if damaged or missing.

65080 SW 7125076 enUS

⚠ ADVERTENCIA

EVITE LESIONES O LA MUERTE

- Asegúrese de que el interruptor del asiento esté debidamente montado y funcione correctamente.
- Reemplace el interruptor o los componentes si están dañados o faltan.

65080 SW 7125076 ar

⚠ AVERTISSEMENT

RISQUE DE BLESSURE OU DE MORT

- Assurez-vous que le contacteur du siège est bien installé et qu'il fonctionne correctement.
- Remplacez le contacteur et les composants s'ils manquent ou sont abîmés.

65080 SW 7125076 fr

SPECIFICATIONS

COMPACT TRACTOR CAPACITIES	211
Compact Tractor Loader Lift Capacity	211
Ballast (Rear)	211
Three-Point Hitch Specifications	212
Towing Weight	212
Maximum Drawbar Tongue Weight	212
Ballast (Front)	212
CT225 SPECIFICATIONS	213
Machine Dimensions (Standard Machine)	213
Machine Dimensions (With Optional Loader, S/N AL4D00101 & Above And AKPD00101 & Above)	214
Machine Dimensions (With Optional Loader, S/N A91100101 & Above)	215
Performance	216
Controls	216
Engine	216
Hydraulic System	217
Electrical	217
Power Take-Off (PTO) System (Rear-PTO)	217
Power Take-Off (PTO) System (Mid-PTO Optional)	217
Drive System	218
Steering	218
Capacities	218
Tires	219
Loader (If Equipped)	219

CLICK HERE TO **DOWNLOAD** THE COMPLETE MANUAL

- Thank you very much for reading the preview of the manual.
- You can download the complete manual from: www.heydownloads.com by clicking the link below



- Please note: If there is no response to CLICKING the link, please download this PDF first and then click on it.

CLICK HERE TO **DOWNLOAD** THE COMPLETE MANUAL