

9

8

0



Operation & Maintenance Manual

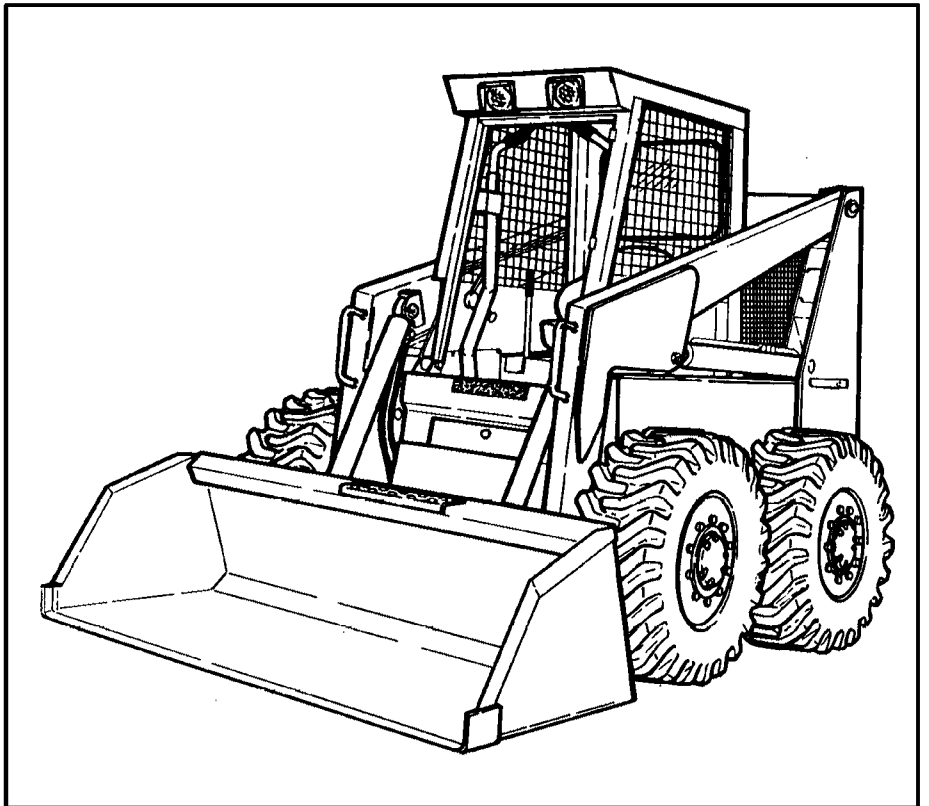

MELROE
INGERSOLL-RAND

6570340 (7-92) Revised (2-96)

Printed in U.S.A.



© Melroe Company 1996

CLICK HERE TO **DOWNLOAD** THE COMPLETE MANUAL

- Thank you very much for reading the preview of the manual.
- You can download the complete manual from: www.heydownloads.com by clicking the link below



- Please note: If there is no response to CLICKING the link, please download this PDF first and then click on it.

CLICK HERE TO **DOWNLOAD** THE COMPLETE MANUAL



bobcat

OPERATING PROCEDURE

Always warm up the engine and the hydrostatic system before operating the loader.

IMPORTANT

Machines warmed up with moderate engine speed and light load have longer life.

I-2015-0284

Operate the loader with the engine at full speed for maximum horsepower. Move the steering levers only a small amount to operate the loader slowly.

New operators must operate the loader in an open area without bystanders.

Operate the controls until the loader can be handled at a safe rate for all conditions of the work area.

Always fill the bucket to the Rated Operating Capacity. The loader will turn better with a full load (Rated Operating Capacity) than with just a part load.

With a full bucket go up and down slopes with the heavy end of the loader toward the top of the slope **A**. Go directly up or down a slope, not across a slope.

Raise the bucket only high enough to avoid obstructions on rough ground.

Filling the Bucket

Push down on the top of the lift pedal until the lift arms are all the way down. Push the top of the tilt pedal to put the cutting edge of the bucket on the ground **B**.

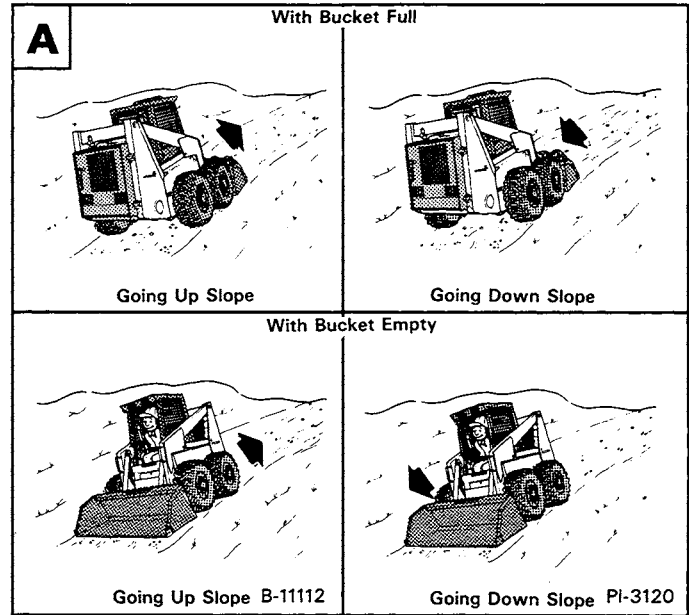

WARNING

- Keep the lift arms as low as possible.
- Do not travel or turn with the lift arms up.
- Turn on level ground.
- Go up and down slopes, not across them.
- Keep the heavy end of the machine uphill.
- Do not overload the machine.

Failure to obey warnings can cause the machine to tip or roll over.

W-2018-1285

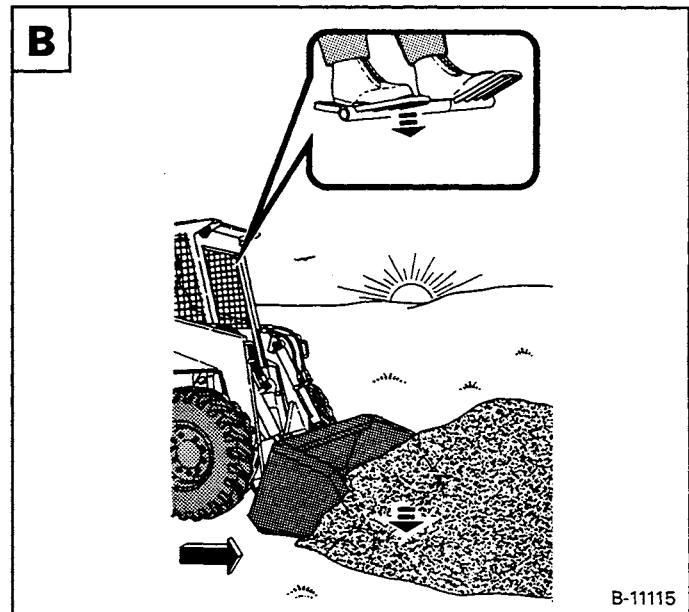

B-11115

PREVENTIVE MAINTENANCE

ALTERNATOR BELT	29
AIR CLEANER	26
CONTROL LEVER LOCK	40
ELECTRICAL SYSTEM	32
Electrical System Service	32
New Battery Installation	34
Using An Extra Battery (Jump Start)	32
ENGINE COOLING SYSTEM	29
Coolant Level	29
Removing Coolant from the Cooling System	29
ENGINE ELECTRICAL DIAGRAM	31
ENGINE LUBRICATION SYSTEM	28
Engine Oil and Filter Replacement	28
FINAL DRIVE TRANSMISSION (CHAINCASE)	8
Drive Chain Adjustment	38
Reduction Gearcase	38
FUEL SYSTEM	27
Fuel Filters	27
Fuel Specifications	27
Removing Air From the Fuel System	27
HYDRAULIC/HYDROSTATIC FLOW CHART	35
HYDRAULIC/HYDROSTATIC SYSTEM	36
Checking and Adding Fluid	36
Hydraulic Fluid Replacement	37
Replacement of the Primary Filter	36
Replacement of the Secondary Filter	37
LIFT ARM STOP	22
LOADER LUBRICATION	40
OPERATOR CAB	25
Lowering the Operator Cab	25
Raising the Operator Cab	25
OPERATOR CAB ELECTRICAL DIAGRAM	30
PLANETARY AXLES	39
REAR DOOR	24
Adjusting Rear Door Latch	24
SEAT BAR SYSTEM	23
Seat Bar Inspection	23
Seat Bar Maintenance	23
SERVICE SCHEDULE	21
SKID PLATE	22
TIRE MAINTENANCE	39
Tire Rotation	39
Wheel Nuts	39

PREVENTIVE
MAINTENANCE

ENGINE COOLING SYSTEM

Keep the air outlet on the rear door clean and free of debris to prevent engine overheating.

Coolant Level

The coolant recovery tank (Item 1) is located by the radiator **A**.

Remove the cap to check the coolant level. The recovery tank must be 1/3 full with the engine cool.

Removing Coolant From the Cooling System

WARNING

Do not remove radiator cap when the engine is hot. You can be seriously burned.

W-2070-1285

Remove the radiator cap.

Open the drain at the engine and at the radiator.

Remove the hose from the engine cooler (Item 1) **B**.

NOTE: If the system is being drained for storage, be sure to remove the oil cooler hose (Item 1) to drain all the coolant out of the system **B**.

After the coolant has been removed, close all the drains and connect the oil cooler hose.

Mix coolant in a separate container. See the Specifications Section for the correct capacity.

NOTE: Protect the cooling system by adding premixed 50% ethylene glycol and 50% water to the system. This mixture will protect the cooling system to -34°F. (-36° C.).

Fill the radiator to the top of the fill pipe with the premixed coolant.

Install the radiator cap. Fill the coolant recovery tank 1/3 full.

Operate the engine for several minutes. Stop the engine and check the coolant level again.

ALTERNATOR BELT

To replace the alternator belt, use the following procedure:

Open the rear door. Slide the left side screen back.

Use a 1/2" drive handle. Install it in the tension pulley bracket **C**.

Lift up on the tension pulley and remove the alternator belt **D**.

Install the new alternator belt. Let the tension pulley go back into position.

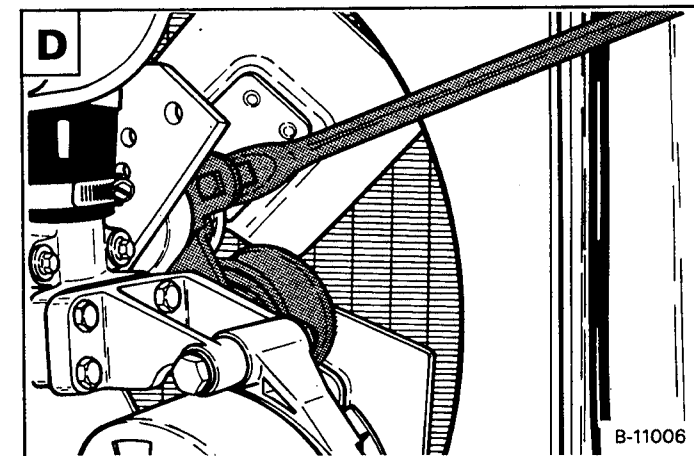
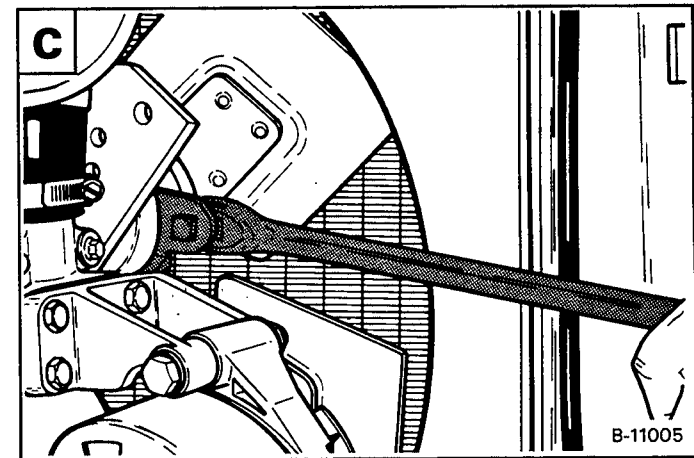
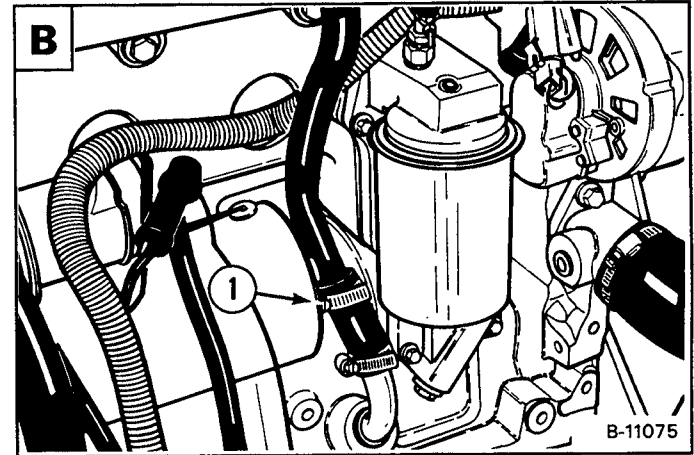
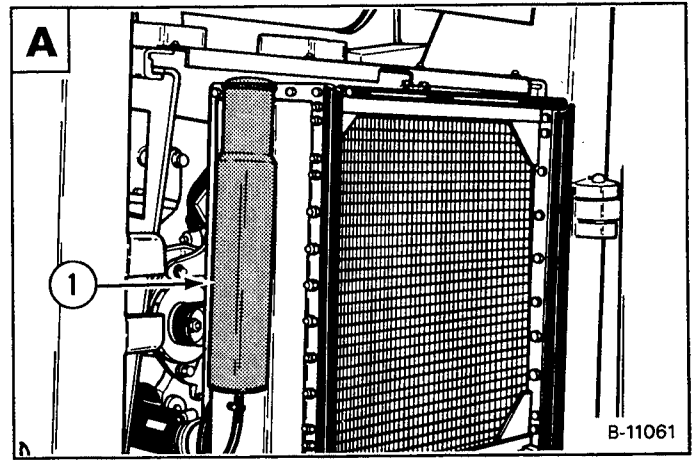

PLANETARY AXLES

See the Service Schedule (Page 21) for the correct service interval.

Put the loader on level ground. Move the loader until the arrow, on the cover casting (of one wheel), is in the down position **A**.

Remove the check plug from one planetary axle only (one axle needs to be checked on each side).

If fluid flows, install plug and tighten.

If no fluid flows, remove side cover. Add fluid until it flows from the check plug. Install the plug and tighten.

NOTE: The final drive (chain case) and the planetary axles use the same Bobcat fluid (P/N 6563328).

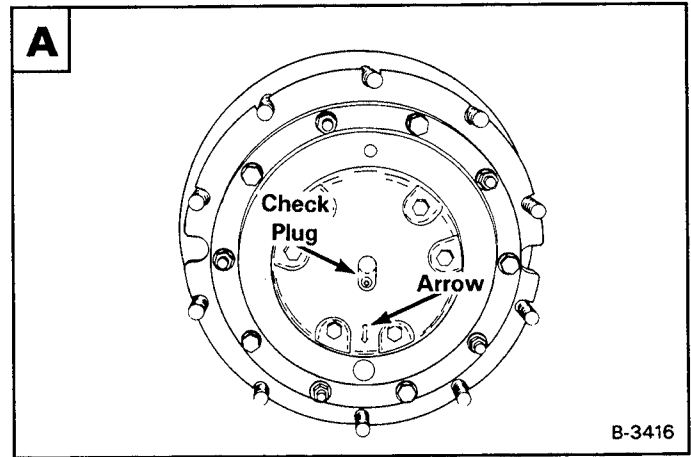

TIRE MAINTENANCE

Check the tires regularly for wear, damage and correct pressure (See Specifications, Page 45).

NOTE: The rear tires are filled with ballast (calcium chloride), a special gauge is needed to check air pressure at the rear

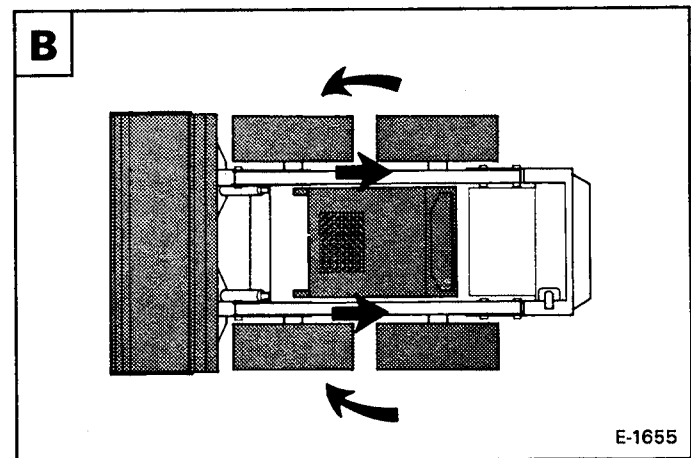

Tire Rotation

Rear tires usually wear faster than front tires. To keep the tire wear even, move the front tires to the rear and the rear tires to the front **B**.

NOTE: The rear tires are filled with ballast (calcium chloride), remove the ballast before rotating the rear tires to the front.

Tires must be the same size and pressure must be maintained to avoid excessive tire wear and loss of stability and handling. Tire pressure must be checked daily. The tires may be inflated above or below operating pressure for shipping. Check for correct pressure before operating the loader.

When installing a tire on a rim, avoid excess pressure which can rupture the tire and cause serious injury. During inflation of the tire, check the tire pressure frequently to avoid over-inflation.

The rim flange must be cleaned and free of rust. The tire bead and rim flange must be lubricated with a rubber lubricant before mounting the tire to avoid damage to the tire and rim.

Wheel Nuts

See the Service Schedule (Page 21) for the service interval to check the wheel nuts. Correct torque is 240-300 ft.-lbs. (325-407 Nm).

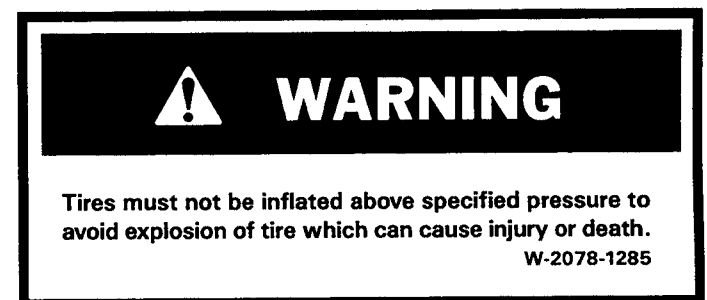

CLICK HERE TO **DOWNLOAD** THE COMPLETE MANUAL

- Thank you very much for reading the preview of the manual.
- You can download the complete manual from: www.heydownloads.com by clicking the link below



- Please note: If there is no response to CLICKING the link, please download this PDF first and then click on it.

CLICK HERE TO **DOWNLOAD** THE COMPLETE MANUAL