

3

7

1



Operation & Maintenance Manual

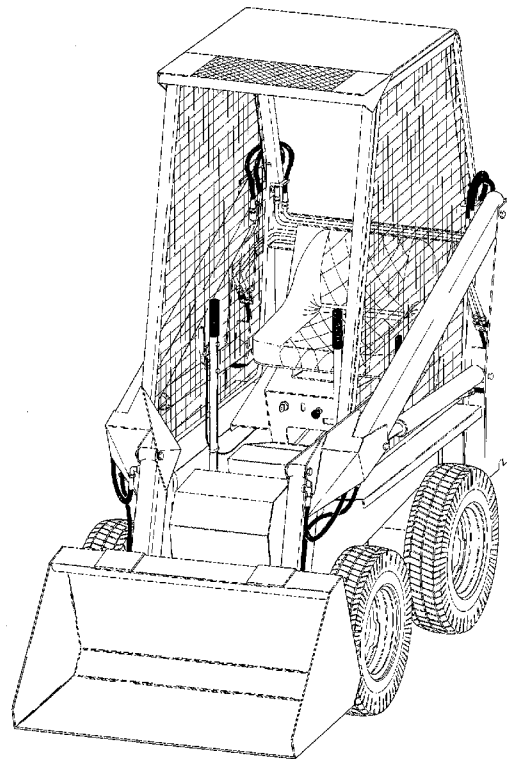

MELROE
INGERSOLL-RAND

6545681 (2-88)

Printed in U.S.A.



© Melroe Company 1988

CLICK HERE TO **DOWNLOAD** THE COMPLETE MANUAL

- Thank you very much for reading the preview of the manual.
- You can download the complete manual from: www.heydownloads.com by clicking the link below



- Please note: If there is no response to CLICKING the link, please download this PDF first and then click on it.

CLICK HERE TO **DOWNLOAD** THE COMPLETE MANUAL

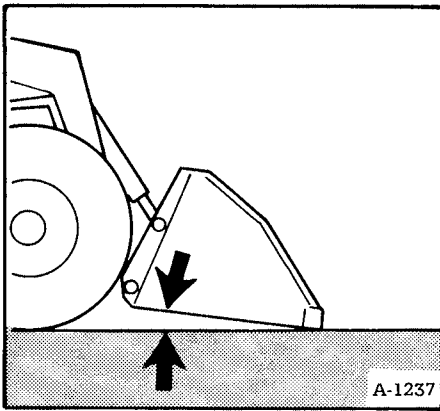

Fig. 15 Digging Angle

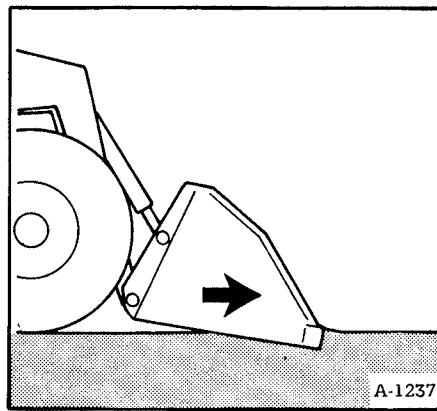

Fig. 16 Starting To Dig

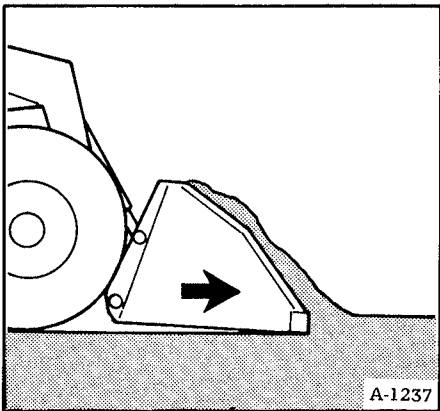

Fig. 17 Filling Bucket

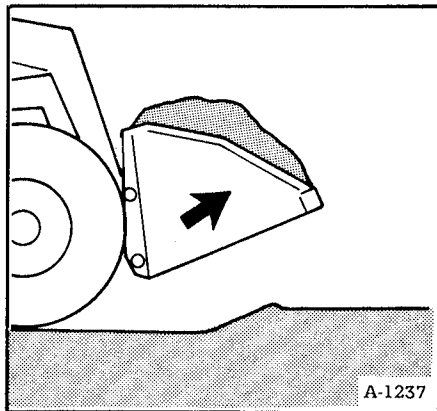

Fig. 18 Leaving Hole

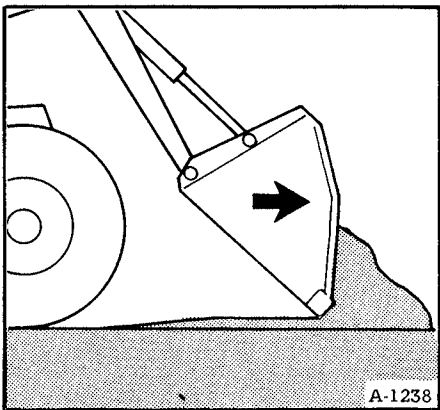

Fig. 19 Spreading Fill

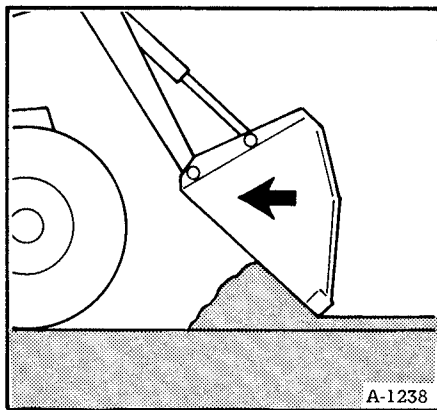

Fig. 20 Leveling

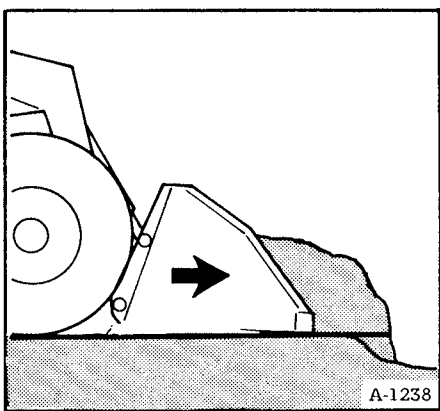

Fig. 21 Filling Holes

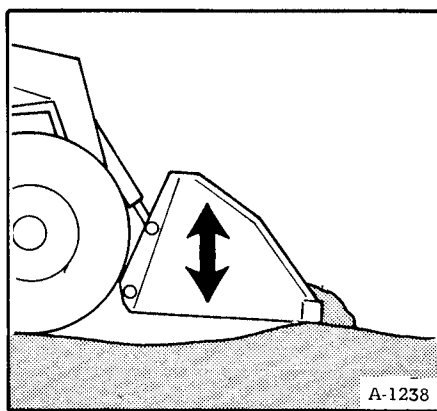

Fig. 22 Uneven Ground

DIGGING WITH THE BUCKET

To dig into hard ground:

1. Raise the boom slightly and tip the bucket down until it contacts the ground (Figure 15).
2. Drive forward to penetrate the ground. Bring the boom down as you drive forward (Figure 16).
3. Raise the bucket slightly to increase traction and to maintain a uniform depth (Figure 17).
4. Continue driving forward until the bucket is filled (Figure 17).
5. When the bucket is filled, roll it back as far as it will go (Figure 18).

LEVELING AND BACKFILLING

1. Spread dirt by driving forward with the bucket raised off the ground and tilted down (Figure 19).
2. To level, tilt the bucket down. Raise the front slightly off the ground and drive backward (Figure 20).
3. Figure 21 shows filling a hole in rough ground.
4. Pressing the heel of the left (boom control) pedal down as far as it will go places the boom in float position. This allows the bucket to follow the contour of the ground (Figure 22).

DUMPING THE BUCKET

Keep the loaded bucket low while moving to an area where you can dump it.

Level the load with the toe of the bucket control (right) pedal as you raise it. This will prevent any material from falling over the back of the bucket.

Press the toe of the bucket control pedal to dump.

If you are dumping into a truck box or onto a trailer bed, and all of the load is being dumped on the near side of the box, push it to the far side with your bucket.

RECTIFIER-REGULATOR

The rectifier-regulator is a sealed unit on which repairs cannot be made.

The rectifier-regulator will be damaged if the engine is operated for any length of time without a battery in the system. A battery with a cracked case with all the acid drained out will also ruin the rectifier-regulator. Under these conditions, the rectifier-regulator over-heats which ruins the solid state electronic devices inside the unit.

Damage will not occur if an engine is run with a dead or completely discharged battery or with a shorted battery.

Check the following:

1. Battery polarity must be correct. A negative ground system is used.
2. Prevent alternator (AC) leads from touching or shorting. This could permanently damage the stator.
3. Disconnect leads at the rectifier-regulator before electric welding is done on the loader.
4. Check the leads on the terminal plug on the wiring harness to see that they are in the correct location (Figure 39). The battery or hot (orange) wire must go to the B+ terminal on the rectifier-regulator.

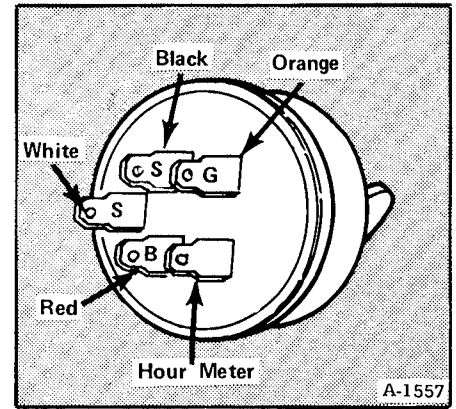

Fig. 39 Ignition Terminal

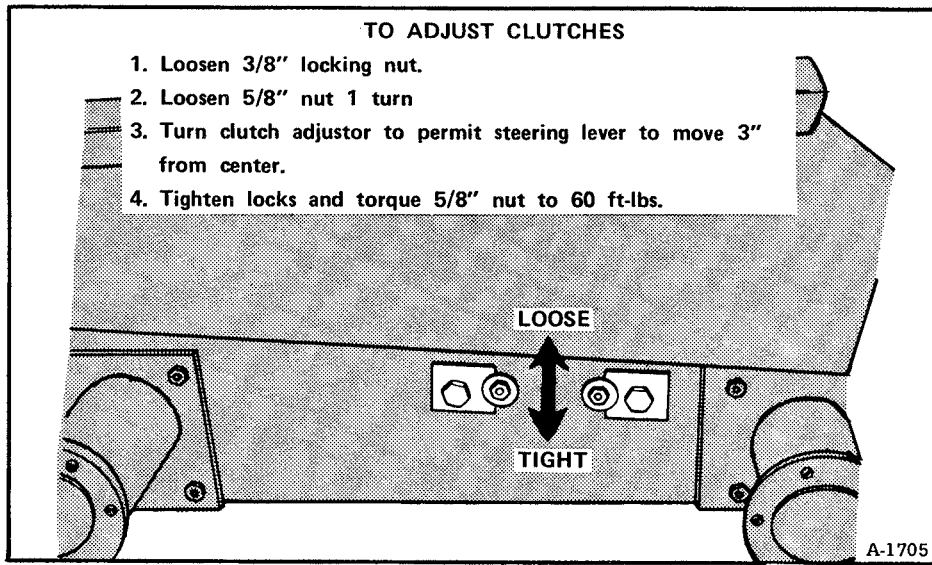

Fig. 55 Clutch Adjustment

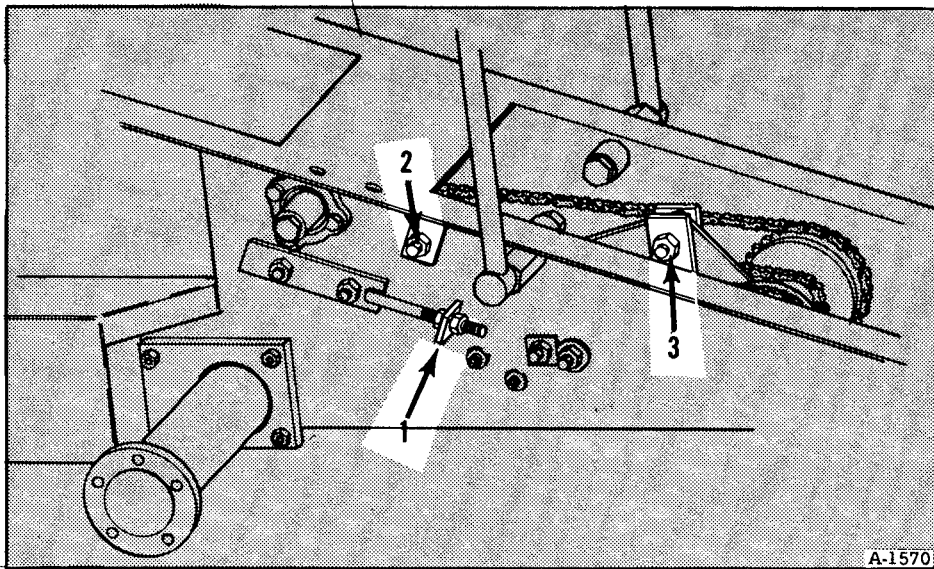

Fig. 56 Drive Train Adjustment

3. Check the tension of the final drive chains. They should have about 1/4" of freeplay with slight finger pressure (Figure 54). Final drive idler sprockets are adjusted from outside of the machine (Figure 56, Item 1). To adjust, loosen the 15/16" and 3/4" bracket holding nuts and turn the adjusting nuts until desired tension is set. After the chain tension has been set it is necessary to align the sprocket while tightening the holding nuts. With the holding nuts loose, the sprocket may be "cocked" at a slight angle. This must be corrected during tightening of the holding nuts or chain scuffing, sprocket wear or bearing failure will result. Tighten the lower 15/16" holding nut first. This will tend to draw the idler up squarely. Further prying with a bar against the innermost edge of the bracket while tightening the 3/4" nut should assure correct alignment. Torque the 15/16" nut to 120 ft-lbs. and the 3/4" nut to 80 ft-lbs. Tighten the adjusting nuts securely.

Check the tension of the outside clutch chains (Figure 51). They should have about 1/4" freeplay with slight finger pressure. The outside clutch chain idler sprockets are adjusted from outside of the machine (Figure 56, Item 2). To adjust, loosen the 5/8" nut and move the idler until desired tension is set. Tighten the nut to 60 ft-lbs. torque.

Check the tension of the inside clutch chains (Figure 53). They should have about 1/4" freeplay with slight finger pressure. The inside clutch chain idler sprockets are located on the divider plate, between the left and right hand drive systems (Figure 56, Item 3). To adjust, loosen the mounting bolts and slide the idlers until desired tension is set. Tighten the holding nuts to 40 ft-lbs. torque.

After all chains have been correctly set, rotate the drive for at least three complete revolutions of the chains, checking each chain at various points of rotation for correct tension. Radial high spots on the sprockets may occur which could cause over-tension of a chain. Readjust chains as necessary to assure that freeplay is not less than 1/4" at any point during rotation.

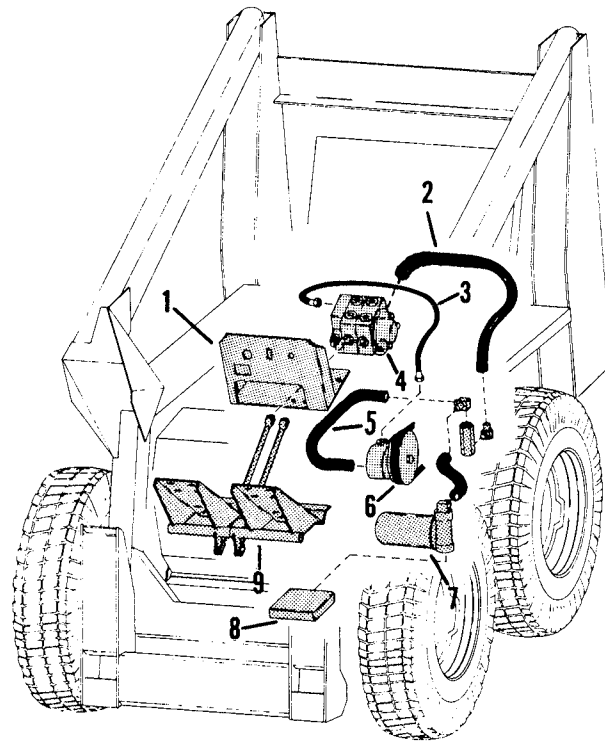

C-1446

MAIN FRAME HYDRAULIC CIRCUITRY

<u>Ref.</u>	<u>Item</u>	<u>Ref.</u>	<u>Item</u>
1.	Valve Mounting Bracket	6.	Hydraulic Pump
2.	Return Hose	7.	Hydraulic Oil Filter Assembly
3.	Pressure Hose	8.	Hydraulic Oil Pickup Baffle
4.	Control Valve	9.	Pedal Assembly
5.	Suction Hose		

CLICK HERE TO **DOWNLOAD** THE COMPLETE MANUAL

- Thank you very much for reading the preview of the manual.
- You can download the complete manual from: www.heydownloads.com by clicking the link below



- Please note: If there is no response to CLICKING the link, please download this PDF first and then click on it.

CLICK HERE TO **DOWNLOAD** THE COMPLETE MANUAL