

# **Operation and Maintenance Manual**

# **R 932**

**Litronic**

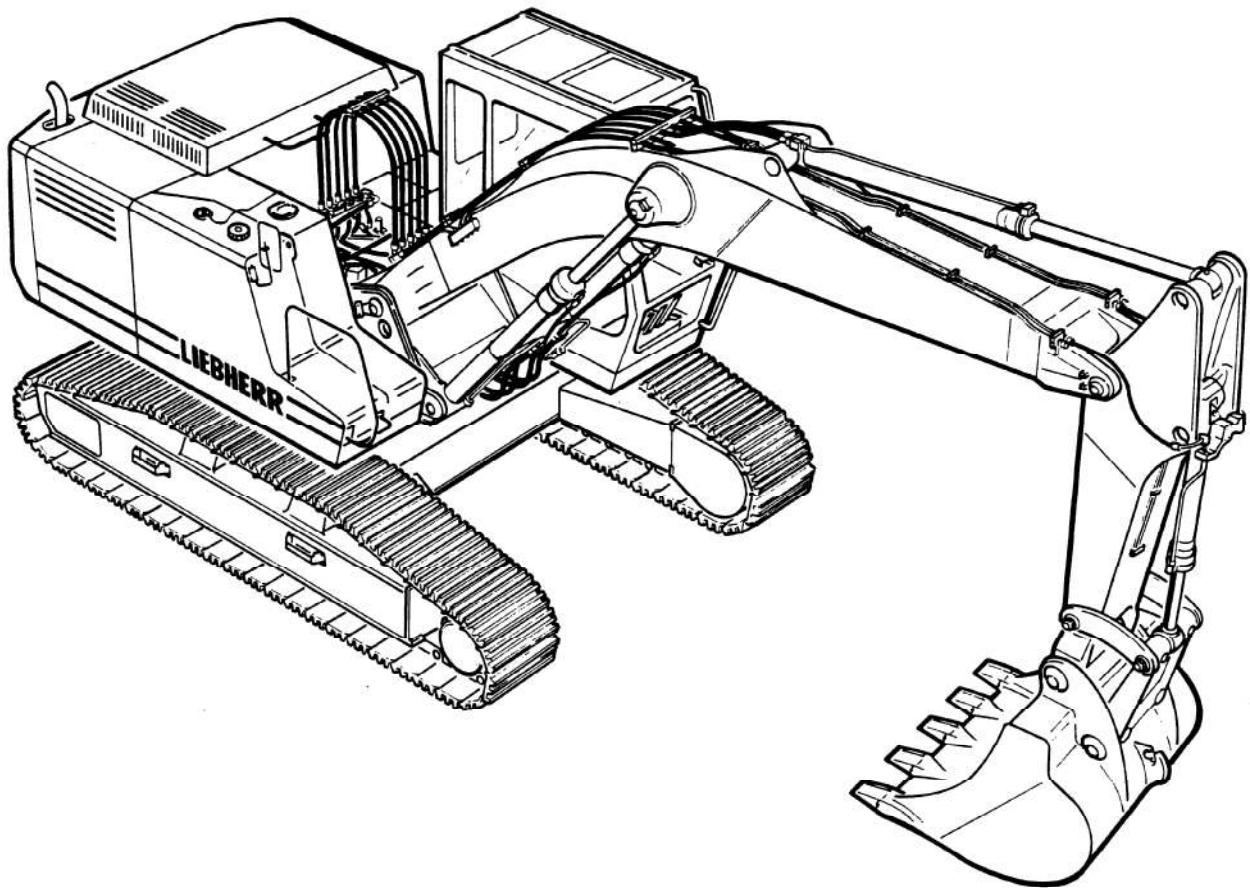

CLICK HERE TO **DOWNLOAD** THE COMPLETE MANUAL

- Thank you very much for reading the preview of the manual.
- You can download the complete manual from: [www.heydownloads.com](http://www.heydownloads.com) by clicking the link below



- Please note: If there is no response to CLICKING the link, please download this PDF first and then click on it.

CLICK HERE TO **DOWNLOAD** THE COMPLETE MANUAL

- **BE CERTAIN THAT THE AREA SURROUNDING THE EXCAVATOR IS FREE OF OTHER PERSONNEL.**
- **BE CERTAIN NO ONE IS WORKING ON OR UNDER THE EXCAVATOR.**
- **AFTER ENTERING THE EXCAVATOR, ADJUST THE OPERATOR'S SEAT AND CONTROLS, ADJUST THE MIRRORS, AND, IF INSTALLED, FASTEN AND ADJUST THE SEAT BELT.**  
Be certain that all controls can be reached.
- **CLEAN ALL WINDOWS AND SECURE SLIDING WINDOWS AND DOORS.**
- **ALERT NEARBY PERSONNEL THAT THE EXCAVATOR IS BEING STARTED.**

## **ENGINE START UP AND OPERATING SAFETY**

- **PLACE ALL CONTROLS IN NEUTRAL POSITION BEFORE STARTING THE ENGINE.**
- **FOLLOW THE ENGINE STARTING INSTRUCTIONS.**  
These instructions are outlined in the Instruction and/or Operation and Maintenance Manual.
- **CHECK ALL LIGHTS, INDICATORS, INSTRUMENTS AND CONTROLS FOR THEIR PROPER FUNCTION. PLACE ALL CONTROLS IN NEUTRAL POSITION BEFORE STARTING THE ENGINE.**
- **START THE ENGINE AND CHECK INDICATORS, GAUGES, WARNING DEVICES AND CONTROLS FOR THEIR PROPER INDICATION.**
- **START AND OPERATE THE ENGINE ONLY IN A WELL VENTILATED AREA.**  
If necessary, open doors and windows.
- **WARM UP THE ENGINE AND HYDRAULIC SYSTEM TO OPERATING TEMPERATURES.**  
Low engine and hydraulic oil temperatures cause the excavator to be unresponsive.
- **CHECK THAT ALL ATTACHMENT FUNCTIONS ARE PROPERLY OPERATING.**
- **MOVE THE EXCAVATOR SLOWLY INTO AN OPEN AREA AND CHECK ALL TRAVEL FUNCTIONS FOR THEIR PROPER OPERATION.**

## **MACHINE OPERATING SAFETY**

- **FAMILIARIZE YOURSELF WITH JOB SITE RULES.**  
Be informed about traffic, hand signals, and safety signs. Ask who is responsible for signaling.
- **OPERATE THE EXCAVATOR ONLY WHILE SEATED AND WITH THE SEAT BELT FASTENED (IF INSTALLED).**
- **NEVER ALLOW OTHER PERSONNEL ON THE EXCAVATOR.**
- **REPORT PROBLEMS OR NEEDED REPAIRS TO YOUR FOREMAN OR SUPERVISOR. MAKE SURE THEY ARE CORRECTED.**
- **BE CERTAIN THAT NO ONE IS BEING ENDANGERED BY MOVING THE EXCAVATOR.**
- **CHECK THE BRAKE AND STEERING SYSTEM.** The proper operation of the brake and steering system is outlined in the Operation and Maintenance Manual.
- **NEVER LEAVE THE EXCAVATOR WHILE THE ENGINE IS RUNNING OR IF THE EXCAVATOR IS IN MOTION.**
- **KEEP THE ATTACHMENT CLOSE TO THE GROUND.**
- **KEEP A SAFE DISTANCE FROM OVERHANGS, WALLS, DROP OFFS AND UNSTABLE GROUND.**

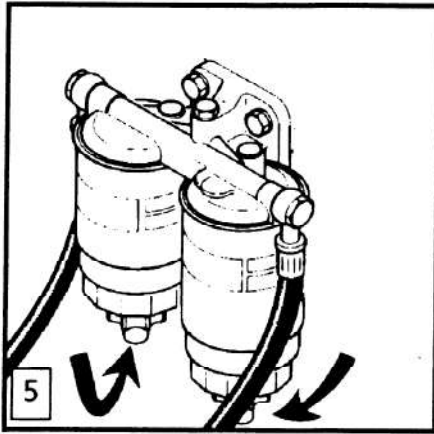

## CHECK FUEL SYSTEM / FUEL LEVEL



### WARNING

Do not store Diesel fuel on the machine or in glass containers. Do no smoke while refueling!

The condensation in the fuel system and fuel tank must be checked daily.

Turn the plug on the water separator, drain the condensation until fuel drains off and retighten the plug (Fig. 5).

Until ideal operating conditions, this interval may be extended to one week.

Check the fuel gauge on the instrument panel (Fig. 6, pos. 56) before starting to work.

If the red diode 62 of the indicator 56 lights up, only a little reserve of fuel remains in the tank.

For remaining quantity, see page 3.5

Refill the tank, if fuel level is low. Maintain a high fuel level in tank to reduce condensation.

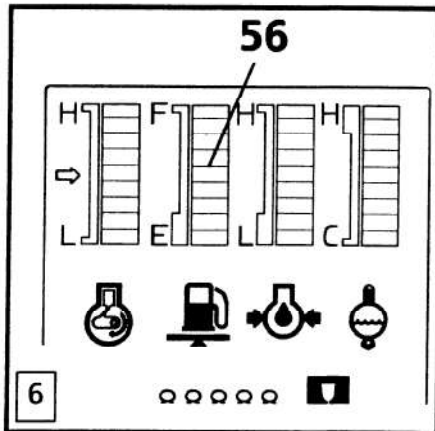

## HYDRAULIC OIL

When checking the oil level or adding oil,

- park the machine on level ground,
- rest the attachments on the ground,
- with stick and tilt cylinders fully extended
- turn the engine off.

### Check oil level in the hydraulic tank

If, in this position, the oil level is below level "II" on the sight gauge (fig. 7), oil has to be added through the return filter until the oil reaches level "II".

See page 5.10 for description of procedure for adding oil.

Level "III" shows the maximum oil level when all cylinders are retracted.

Level "I" shows the minimum oil level when all cylinders are extended.

If the oil level drops below the level "I" on the sight gauge, the indicator light 77 lights up and, at the same time, the pumps will move to minimum angle.

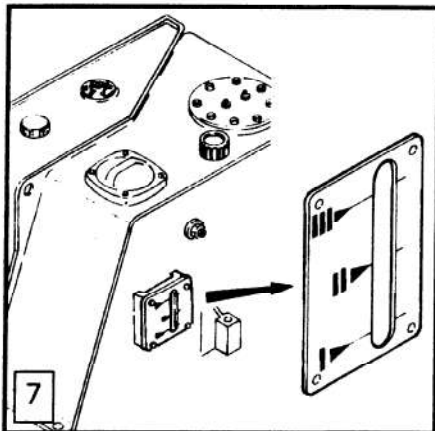

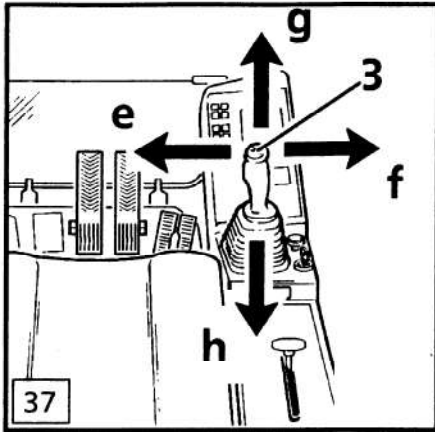

**CONTROL OF BOOM CYLINDER (left lever - fig. 37, pos. 3)**

Push joystick 3 forward (g) to lower the attachment (Fig. 38)

Pull the joystick 3 backward (h) to lift the attachment.

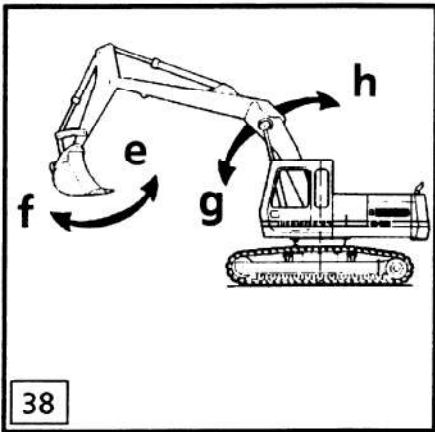

**CONTROL OF THE BUCKET OR GRAPPLE CYLINDER**

Push the joystick 3 (fig 37) to the left (e) to tilt the bucket in or close the grapple (fig. 38 and 39).

Push the joystick 3 to the right (f) to tilt the bucket out or open the grapple.

**⚠ DANGER**

**NEVER ALLOW ANYBODY TO GUIDE THE GRAPPLE BY HAND!**

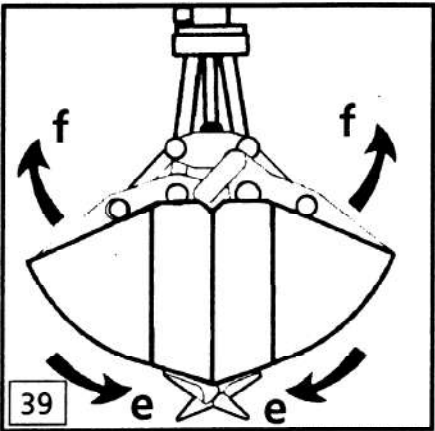

**CONTROL OF HYDRAULIC HAMMER ATTACHMENT**

The hydraulic hammer can be actuated via the pilot control valve 7 (fig.40), mounted into the floor of the cab.

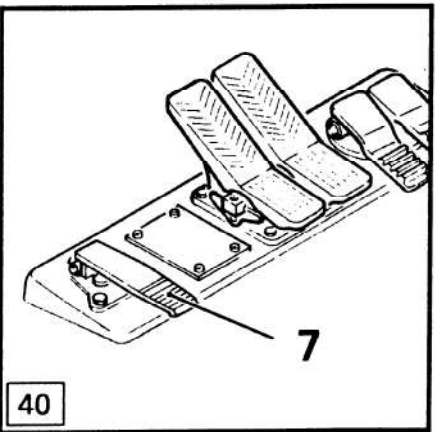

# INSTALLATION AND REMOVAL OF GRAPPLE TO STICK

## INSTALLATION

Before installation of a two shell or multi shell grapple, make sure that all necessary hydraulic lines are installed on the stick.

If necessary, remove the bucket as described on page 4.20.

Retract the bucket cylinder all the way and turn the engine off.

Push the bracket carrier 8 between connector bracket 7 and push in right lever 9, secure with cotter pin 10.

Position the grapple with shells open. Start the engine and move the attachment until the lower bore holes of the stick fits between the bore holes of the grapple suspension.

Insert pin 4 and secure with plate 6.



**DANGER**

---

If another person is used as a guide during this installation procedure, the operator must follow the signals given by this person.

---

Connect the hydraulic hoses 11 and 12 for the shell cylinder to the hydraulic lines of the bucket cylinder circuit.

For grapple with hydraulic rotator, hoses 13 and 14 must be connected to the hydraulic lines for added functions on the stick.

### Grapple operation:

Move the shut off lever on block 15 to position A to cut off the oil flow to the piston bottom side of the bucket cylinder.

Lubricate the different lube points on pin 4 and on the grapple mechanism.

Perform all attachment functions several times without load (open and close bucket, turn the grapple in both directions) to release air from the hydraulic system.

## REMOVAL

Position the grapple with shells open on flat ground surface.

Turn the engine off, turn the ignition key to contact position, move the right joystick (for tilt cylinder) to the left and right and release pressure in the hydraulic tank.







For grapple with hydraulic rotator, push also both buttons on the joystick to relieve the pressure in the swing circuit.

Disconnect two hoses 11 and 12, and if present, two hoses 13 and 14 from hydraulic lines on stick, and immediately close off open lines to prevent contamination.

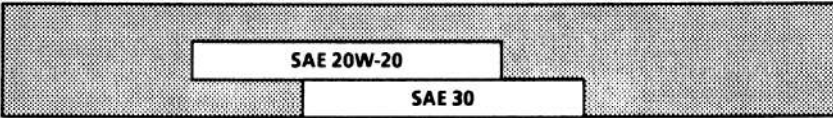
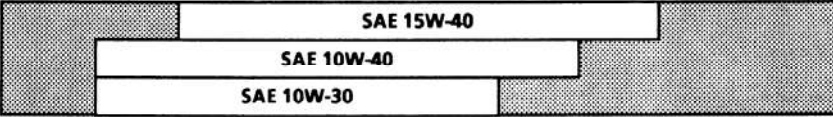
Support the grapple and carefully drive out the pin. If necessary, start the engine and lift the attachment slightly.

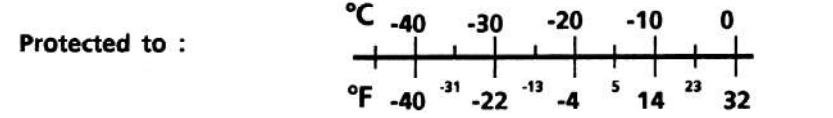
To put the bucket cylinder back in operation, move the shut off lever in block 15 again to position B.

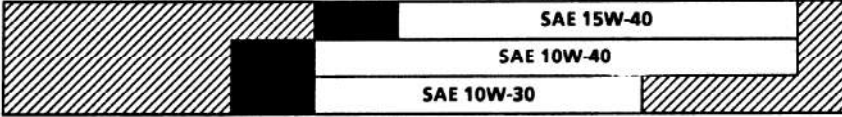
# LUBRICANT AND FUEL CHART R 932 Litronic

COMPONENTS	SYMBOL	VISCOSITY SAE DIN 51512	SPECIFICATION	QUANTITY
DIESEL ENGINE (TURBOCHARGED)				18.5 l. 4.9 US gal.
				
- lubricant		°C -20 -10 0 +10 +20 +30 +40 +50 +60 °F -4 5 14 23 32 41 50 59 69 77 86 95 104 113 122		
		- Below -25°C (-13°F) preheat the engine before starting API: CD/SE resp. CD/SF™ SHPD™ oils		
- fuel		Use only Diesel fuels with a sulfur content of less than 0,5%.		390 l. 103 US gal.
- antifreeze		Ethylen glycol based antifreeze and anticorrosive mixture Protected to :		40 l. 10.6 US gal.
				
		% of antifreeze		
		The percentage of antifreeze should not exceed 60%. Pure undiluted antifreeze will freeze at -10°F (-23°C).		
HYDRAULIC SYSTEM				in hydraulic tank 320 l. 85 US gal.
		°C -40 -30 -20 -10 0 +10 +20 +30 +40 +50 °F -40 -31 -22 -13 -4 5 14 23 32 41 50 59 69 77 86 95 104 113 122		
				in hydraulic system 503 l. 133 US gal.
		Warming up the hydraulic system:		
		1. For temperatures 18°F (10° C) below the lower limits :  Run engine at half speed. Warm up the hydraulic system by fully actuating hydr. cylinders and motors for short periods. Continue warm up for about 10 minutes or until operating temperatures are reached.		
		2. For temperatures below the limits listed under 1 : Preheat hydraulic oil in the tank before starting the engine.		

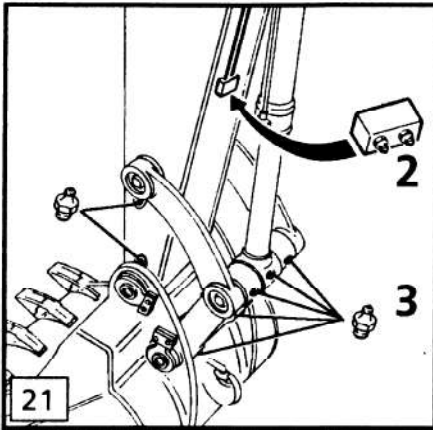

On the bucket, the different grease fittings are installed separately ( fig. 21, pos. 3).

Add grease on every grease fitting daily or after every shift change, until clean grease runs out of the bearing points.

See the lubricant chart for grease specification.

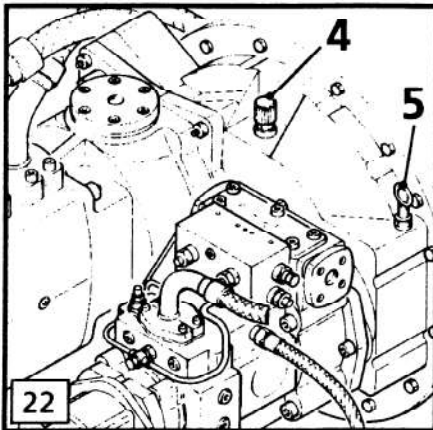

## CHANGING THE OIL IN THE SPLITTERBOX

Fig. 22, pos. 4 shows the oil filler and bleeder screw of the splitterbox and pos. 5 shows the dipstick to check the oil level.

### TO CHECK THE OIL LEVEL

Check the oil level a few minutes after turning off the engine.

### TO DRAIN THE OIL

Drain the oil when the oil is at operating temperature. To drain, remove the cap on the drain 7 (fig. 23), install drain hose 6 and drain the oil into an appropriate container.

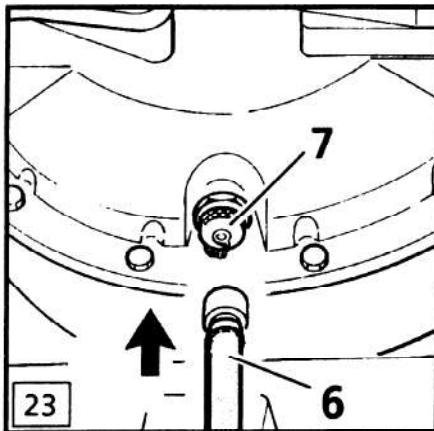

### TO ADD OIL

Add oil to the oil level mark on the dipstick, run the engine for a few minutes, stop it and recheck the oil level.

See lubrication chart for oil quantities and specifications.

See maintenance chart for oil change intervals.

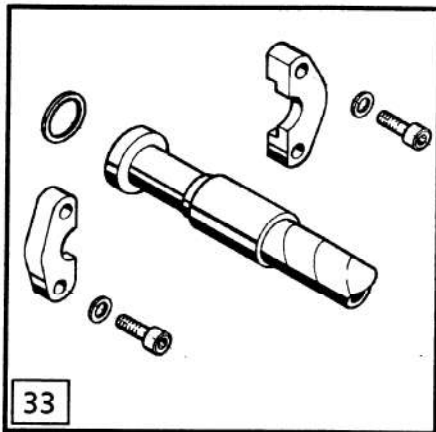

NW 20 high pressure hoses and NW 25 high pressure hoses with SAE fittings are installed on the R 932 Litronic (Fig. 33).



Any time a high pressure hoses is defective (bubbles, moisture, damage on the surface, etc.), it must be replaced. When installing the replacement hose, avoid any stress and strain on the hose.

**Do not turn or twist the hose!**

The following O-rings are needed for hydraulic hoses :

NW 20 25 x 3,53 Id. No. 7264008

NW 25 32,9 x 3,53 Id. No. 7264508

The mounting screws on the SAE fittings are to be tightened to the following torque values :

M10 : 75 Nm (54 ft. lbs)

M12 : 130 Nm (96 ft. lbs)

M14 : 205 Nm (150 ft. lbs)

#### REMOVING THE SUCTION HOSE

If suction hoses have to be removed, the shut off valve at the hydraulic tank has to be closed. Turn the valve by 90° to close (Fig.35).

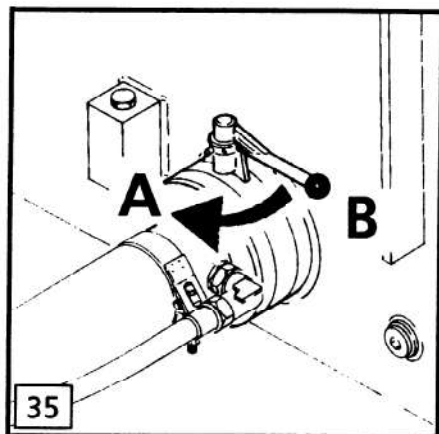

- A - Open
- B - Closed

After the tank pressure is relieved, remove the drain valve on the suction hose fitting on the side of the pump and drain the hydraulic oil from the pump into a suitable container.

After repair, be certain to return the valve to its original position , push it in its notch and close the bleeder screw of the hydraulic tank.

Bleed the hydraulic pumps.

#### BLEEDING THE HYDRAULIC PUMPS

Bleed the hydraulic pumps after any repairs on the pumps and/ or after every oil change.

To bleed the main working pump, loosen the leak oil hose (Fig. 36, pos. 2) and let the air escape. As soon as hydraulic oil flows out of the hose, reconnect the leak oil hose.

To bleed the swing pump, loosen the screw 3, let the air escape and retighten the screw as soon as hydraulic oil flows out.

Fill the pumps with hydraulic oil through the same connection or plug before initial start up, or after repairs or replacement.

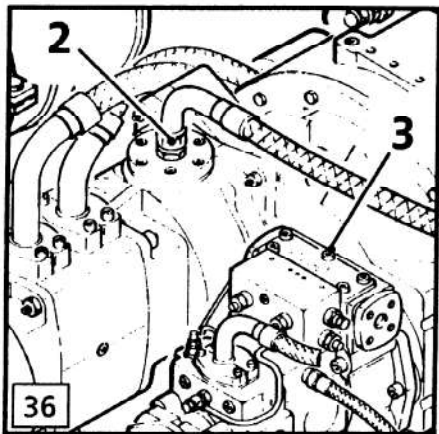

CLICK HERE TO **DOWNLOAD** THE COMPLETE MANUAL

- Thank you very much for reading the preview of the manual.
- You can download the complete manual from: [www.heydownloads.com](http://www.heydownloads.com) by clicking the link below



- Please note: If there is no response to CLICKING the link, please download this PDF first and then click on it.

CLICK HERE TO **DOWNLOAD** THE COMPLETE MANUAL