

# Operation and maintenance manual

# R 912

Litronic

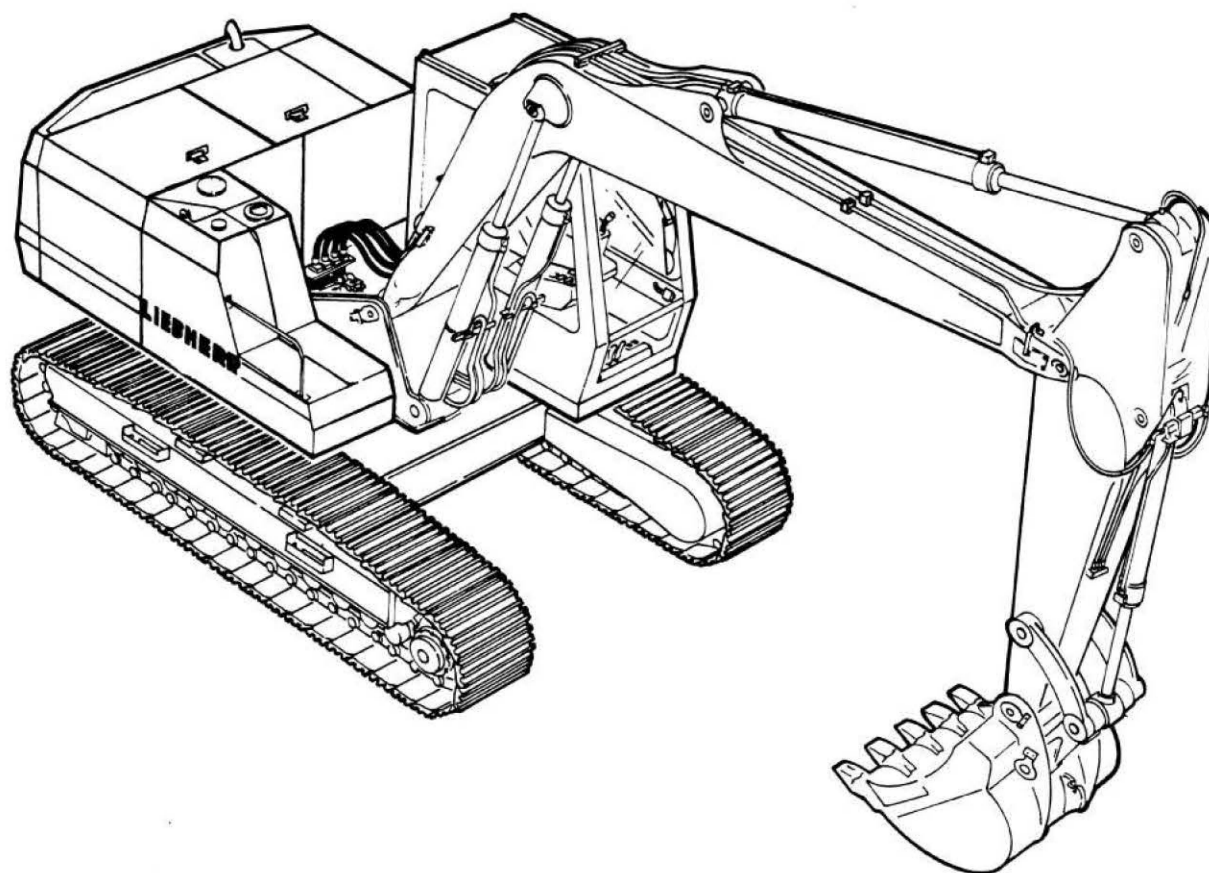

CLICK HERE TO **DOWNLOAD** THE COMPLETE MANUAL

- Thank you very much for reading the preview of the manual.
- You can download the complete manual from: [www.heydownloads.com](http://www.heydownloads.com) by clicking the link below



- Please note: If there is no response to CLICKING the link, please download this PDF first and then click on it.

CLICK HERE TO **DOWNLOAD** THE COMPLETE MANUAL

- **DO NOT CARRY TOOLS, PARTS OR OTHER SUPPLIES WHILE CLIMBING ON OR OFF THE EXCAVATOR.** Climb on and off the excavator using only the steps, rails and handles provided. When climbing on or off the excavator, use both hands for support and face the machine.
- **NEVER JUMP OFF THE EXCAVATOR.**
- **NEVER USE THE STEERING COLUMN, CONTROL LEVERS, OR JOYSTICKS AS HANDHOLDS.**
- **IF NEEDED, USE THE FRONT WINDOW AS AN ESCAPE HATCH.**
- **BEFORE SERVICING THE EXCAVATOR, ATTACH A "DO NOT OPERATE" TAG to the starter switch. IF NOT OTHER GUIDELINES ARE GIVEN, PERFORM MAINTENANCE AND REPAIRS UTILIZING THE FOLLOWING PRECAUTIONS:**
  - Park excavator on firm and level ground. Rest the attachment on the ground.
  - Place all control in neutral position.
  - Turn the engine off and remove the ignition key .
- **BEFORE WORKING ON THE HYDRAULIC CIRCUIT, MOVE ALL JOYSTICKS AND PEDALS WITH IGNITION KEY IN CONTACT POSITION TO RELIEVE THE SERVO PRESSURE AND THE REMAINING PRESSURES IN THE DIFFERENT MAIN CIRCUITS. ALSO RELIEVE THE PRESSURE IN THE HYDRAULIC TANK BY TURNING THE BLEEDER SCREW**
- **ALWAYS TILT UP THE SAFETY LEVER BEFORE LEAVING THE DRIVER'S SEAT.**
- **NEVER ATTEMPT MAINTENANCE PROCEDURES OR REPAIRS YOU DO NOT UNDERSTAND.**
- **NEVER SERVICE THE EXCAVATOR WITH THE ENGINE RUNNING UNLESS OTHERWISE SPECIFIED IN THE INSTRUCTION AND/OR OPERATION AND MAINTENANCE MANUAL.**
- **SECURE ALL LOOSE PARTS ON THE EXCAVATOR.**
- **NEVER OPERATE THE EXCAVATOR WITHOUT A COMPLETE WALK AROUND INSPECTION.** Check if all warning decals are on the machine and legible.
- **FOR CERTAIN SPECIAL APPLICATIONS, THE EXCAVATOR MUST BE EQUIPPED WITH SPECIFIC SAFETY EQUIPMENT. USE THE EXCAVATOR ONLY ,IF THEY ARE INSTALLED AND FUNCTIONING.**

## **CRUSHING AND BURN PREVENTION**

- **NEVER WORK UNDERNEATH OR ON THE EXCAVATOR UNLESS IT IS PROPERLY BLOCKED AND SUPPORTED.**
- **NEVER USE DAMAGED OR INSUFFICIENT WIRE ROPES OR SLINGS.** Always wear gloves when handling wire ropes.
- **NEVER REACH INTO BORES DURING ATTACHMENT INSTALLATION OR REMOVAL.** Never align bores with your fingers or hands. Use proper alignment tools when installing, changing or servicing attachments.
- **KEEP OBJECTS AWAY FROM THE RADIATOR FAN.** Rotating fans will swirl and throw out objects, which can become very dangerous and cause severe injury to yourself and others.
- **AVOID CONTACT WITH COMPONENTS CONTAINING COOLANT.** At or near operating temperature, the engine coolant is hot and under pressure, and could cause severe burns.
- **CHECK THE COOLANT LEVEL ONLY AFTER RADIATOR CAP IS COOL ENOUGH TO TOUCH.** Remove radiator cap slowly to relieve pressure.
- **DO NOT ALLOW YOUR SKIN TO COME INTO CONTACT WITH HOT OIL OR COMPONENTS CONTAINING HOT OIL.** At or near operating temperature, engine and hydraulic oil is hot and can be under pressure.
- **ALWAYS WEAR SAFETY GLASSES AND PROTECTIVE GLOVES WHEN HANDLING BATTERIES.** Keep sparks or open flame away!
- **NEVER PERMIT ANYONE TO HAND GUIDE THE BUCKET OR GRAPPLE INTO POSITION.**



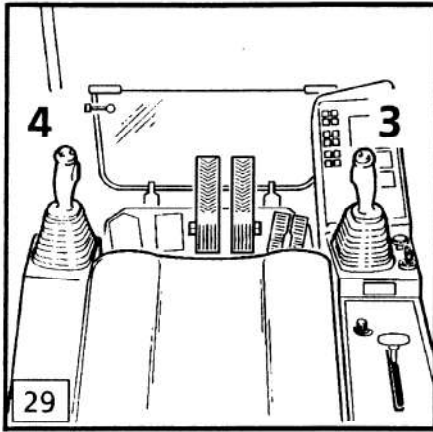

## LOCATION OF THE TWO JOYSTICKS

The right lever (Fig. 29, pos. 3) :  
- Boom and bucket movements

The left lever (Fig. 29, pos. 4) :  
- Stick and swing movements

## CONTROL OF THE SWING (left joystick)

Moving the joystick (Fig. 30, pos. 4) to the left (c) causes the uppercarriage to turn to the left (Fig. 31).

Moving the joystick 4 to the right (d) causes the uppercarriage to turn to the right (Fig. 31).

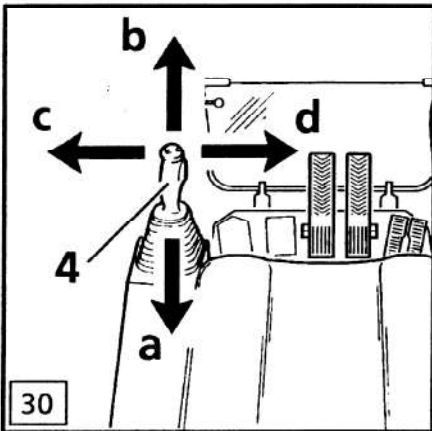

## SWING BRAKE

### Hydraulic service brake

A sufficient deceleration of the uppercarriage is achieved by moving the swing joystick to neutral position.

By moving the joystick to the opposite direction, maximum hydraulic braking is achieved.

Pushing down the optional mounted brake pedal 89 (see page 3.3, fig.12), also causes maximum hydraulic braking.

### Mechanical parking brake

A multi disk swing brake, which is integrated in the swing gear, serves as an additional mechanical brake.

The brake is negatively acting, hydraulically actuated and serves as a holding or parking brake.

When working, the swing can be locked in any position with this brake.

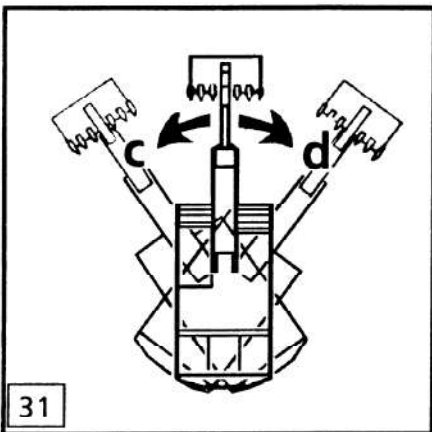

### a) Standard equipment

The swing brake is actuated via the push button (Fig. 32, pos. 32) :

The brake is applied , the red indicator light lights up.

When the push button indicator light is off, the brake is released.



**APPLY THE BRAKE ONLY WHEN THE UPPERCARRIAGE IS NOT MOVING!**

In order to stop the uppercarriage when working on a slope, first stop its movement with joystick 4.

Then apply the brake via push button 32 and move joystick 4 to "O" position.

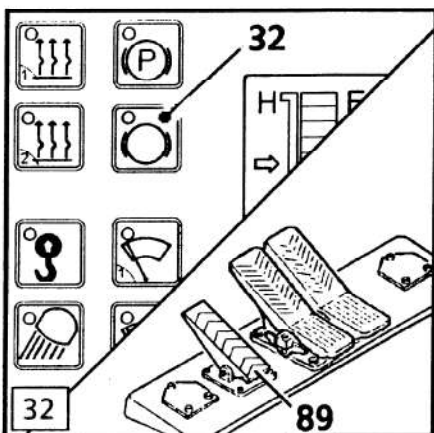

# REMOVAL AND INSTALLATION OF BACKHOE, DITCH CLEANING BUCKET, OR RIPPER

## REMOVAL

Lower the attachment until the flat part of the bucket rests on the ground.

Remove plates 5 and 6 and drive out pins 3 and 4.

If necessary, lift the attachment slightly to remove pin 4.

## INSTALLATION

Position the bucket so the flat part of the bucket rests on the ground.

Start the engine and move the attachments until the stick and bucket bore holes 1 align.

Insert pin 4 and secure with plate 6.

Slowly extend the stick cylinder until the bore of the connector bracket 7 is exactly between bore holes 2.

Insert pin 3 and secure with plate 5.

Lubricate all bearings of pins 3 and 4 until clean grease emerges.



## OIL IN THE HYDRAULIC SYSTEM

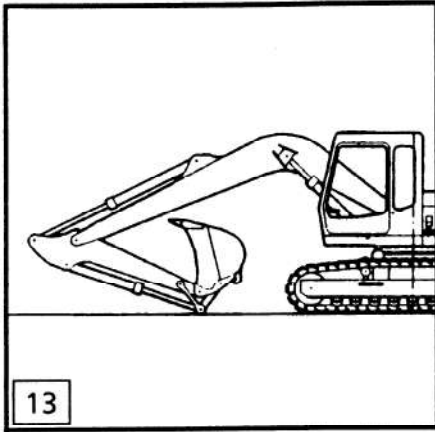

When checking the oil level or adding oil (Fig. 13),

- park the machine on level ground,
- rest the attachments on the ground,
- with stick and tilt cylinders fully extended
- turn the engine off.

After engine shut down, wait for 3 minutes if the oil is cold, resp. for 1 minute if oil is at working temperature before checking the oil level.

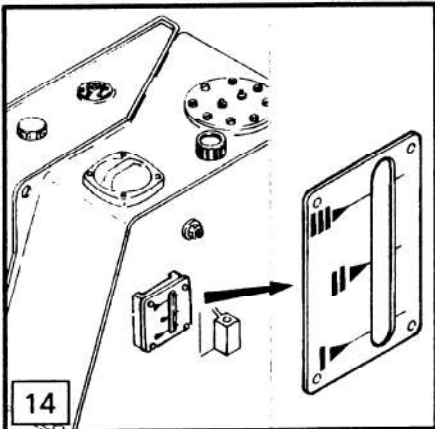

### CHECK HYDRAULIC OIL LEVEL

In this position the oil level may not drop below level "II" on the sight gauge (fig. 14 ) or oil must be added to the tank.

Level "III" shows the maximum oil level when all cylinders are retracted.

Level "I" shows the minimum oil level when all cylinders are all the way extended.

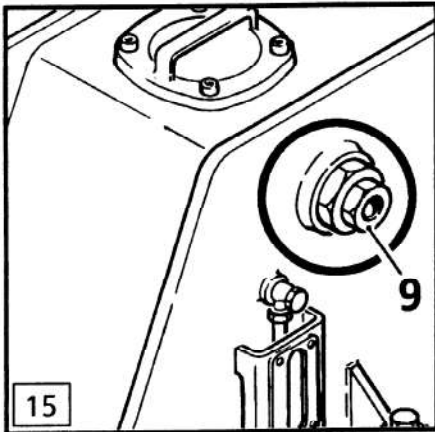

### TO ADD OIL TO THE HYDRAULIC TANK



**WARNING**

Before draining the tank or removing the cover on the oil return filter, you always must first open the breather valve (fig. 15, pos.9) a little to relieve tank pressure (fig. 15).

Remove the cover of the return filter (fig. 16) and add oil via the filter element until the oil level reaches level "II" on the sight gauge.

Reinstall cover and close breather valve.

The hydraulic system should always be refilled or drained using a filler pump.

The tank can also be drained with the drain hose connected to the drain valve on the bottom of the tank.

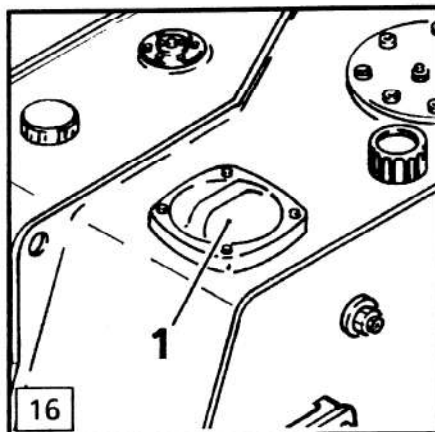

**CAUTION**

The hydraulic pumps must be bled after every oil change (see page 6.10).

See lubricant chart for oil specifications and maintenance chart for oil change intervals.

## THE TRACK COMPONENTS

The tracks are maintenance free until the track pads or flanges need to be reconditioned or replaced.

The lifetime seals in carrier rollers, track rollers and idlers increase the life expectancy of the tracks and protect from dirt and contamination.

However, even though the track is virtually maintenance free, the following points do need to be checked.

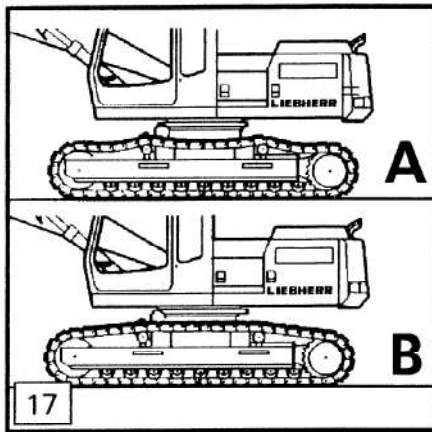

### TIGHTENING THE TRACK TENSION

Fig. 17 A shows a track, that is not tightened properly, Fig. 17 B shows a track that is tightened properly.

The track tension needs to be checked regularly due to normal wear of the tracks, and tightened, if necessary.

The track chain tension is correct when the slack between both carrier rollers is about 1.2" (30 mm).

To check the chain slack (fig. 18) :

- measure  $X_1$ , distance between running surface of carrier roller and top of sideframe
- measure  $X_2$ , distance between chain left and top of sideframe
- calculate chain slack =  $X_1 - X_2$ .

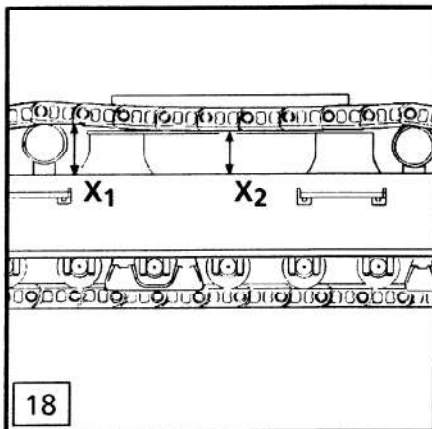

To tighten a track :

Remove the access cover (Fig. 19, pos. 4) on the side frame of the undercarriage.

Attach a special fitting 2 to grease gun 1 (Fig. 20). Connect the grease gun to cylinder 3.

Pump grease into cylinder 3 until the track chain is properly tensioned.

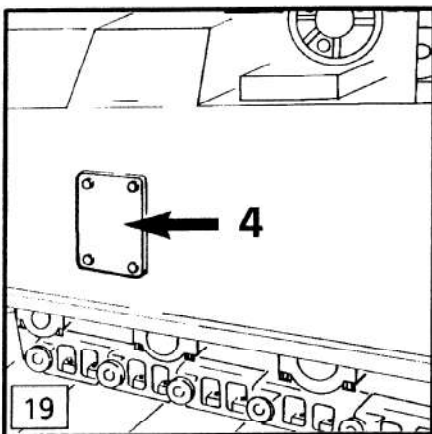

To release track tension, carefully release some grease from the grease cylinder by loosening and turning the grease fitting counterclockwise.



### WARNING

When adjusting the chain tension, keep your head clear of the access hole. The grease cylinder is under high pressure and the chain will sag. Grease is under high pressure and might squirt out.

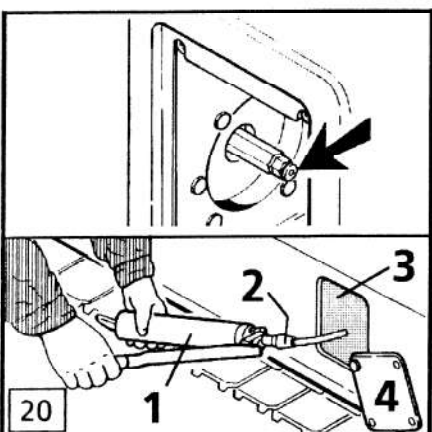

CLICK HERE TO **DOWNLOAD** THE COMPLETE MANUAL

- Thank you very much for reading the preview of the manual.
- You can download the complete manual from: [www.heydownloads.com](http://www.heydownloads.com) by clicking the link below



- Please note: If there is no response to CLICKING the link, please download this PDF first and then click on it.

CLICK HERE TO **DOWNLOAD** THE COMPLETE MANUAL