

Operation and Maintenance Manual

R 924

Litronic

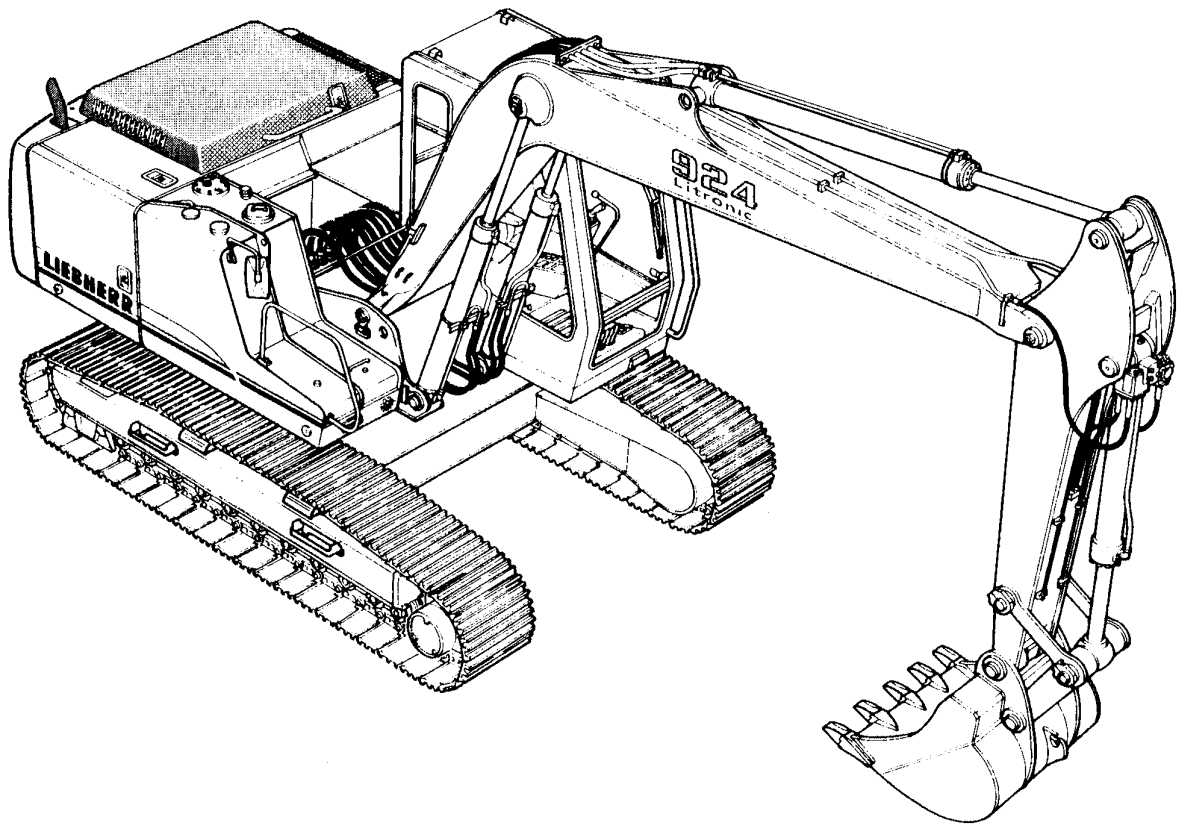

CLICK HERE TO **DOWNLOAD** THE COMPLETE MANUAL

- Thank you very much for reading the preview of the manual.
- You can download the complete manual from: www.heydownloads.com by clicking the link below



- Please note: If there is no response to CLICKING the link, please download this PDF first and then click on it.

CLICK HERE TO **DOWNLOAD** THE COMPLETE MANUAL

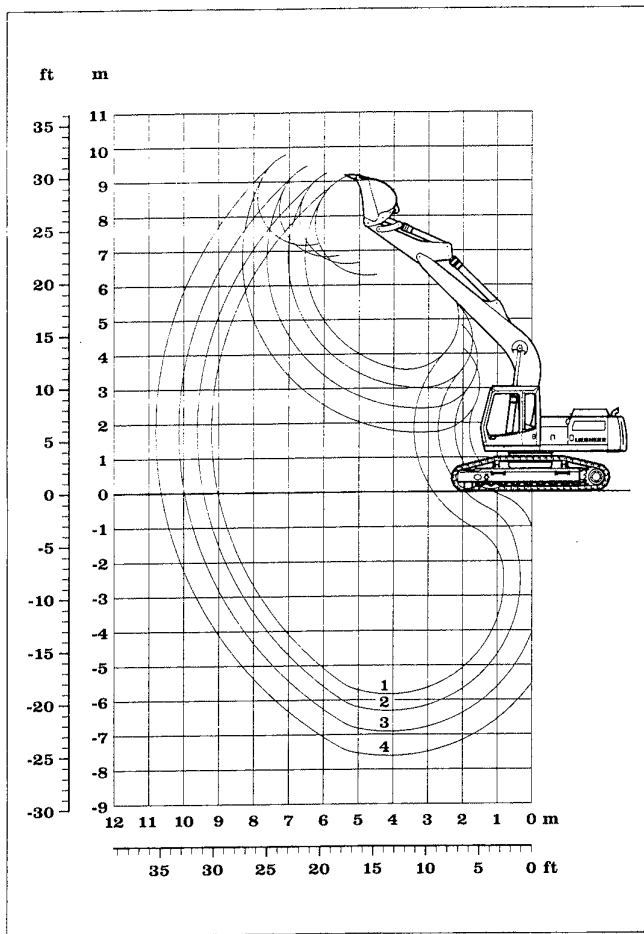

Digging envelope

- 1 with stick 1,80 m
- 2 with stick 2,40 m
- 3 with stick 3,00 m
- 4 with stick 3,70 m

Stick lengths	m	1,80	2,40	3,00	3,70
Max. digging depth	m	5,85	6,30	6,90	7,60
Max. reach at ground level	m	9,00	9,45	10,00	10,65
Max. dump height	m	6,30	6,60	6,85	7,20
Max. teeth height	m	9,20	9,25	9,45	9,80
Digging force	kN/t	169/17,2	132/13,45	114/11,6	98/10,0
Breakout force	kN/t	183/18,7	159/16,2	159/16,2	159/16,2
Max. breakout force	kN/t				194/19,8 ⁴⁾

Operating Weight and Ground Pressure

Operating weight includes basic machine with 5,85 m gooseneck boom, 2,40 m stick and 1,20 m³ bucket.

Undercarriage		HD-SL	
Pad width	mm	600	750
Weight	kg	25800	26220
Ground pressure	kg/cm ²	0,52	0,43

Buckets

Cutting width	mm	370 ¹⁾	440 ¹⁾	490 ¹⁾	550	620 ²⁾	650	850	1050	1250	1400	1400	1550	750 ⁴⁾	1550 ³⁾	1550 ³⁾	1700 ³⁾
Capacity ISO 7451	m ³	0,30	0,35	0,40	0,35	0,30	0,40	0,60	0,80	1,00	1,20	1,40	1,80	0,50	1,50	1,80	2,00
Max. possible material weight	t/m ³	1,8	1,8	1,8	1,8	1,8	1,8	1,8	1,8	1,8	1,8	1,5	1,2	1,8	1,8	1,5	1,2
Weight with Liebherr teeth Z 13	kg	-	-	-	-	-	-	-	-	-	-	-	1055	-	-	-	1200
Weight with Liebherr teeth Z 16	kg	-	-	-	580	850	630	745	830	950	1040	1065	-	1030	1080	1150	-
Weight with Bofors teeth	kg	370	390	410	-	-	-	-	-	-	-	-	-	-	-	-	-
Max. stick length for machine stability per ISO 10567:																	
HD-SL undercarriage		3,70	3,70	3,70	3,70	3,70	3,70	3,70	3,70	3,00	2,40	2,40	2,40	1,80	1,80	1,80	1,80

- ¹⁾ Bucket with ejector and Bofors teeth
- ²⁾ Ripper bucket with teeth size Z 16 P
- ³⁾ Bucket R 934 Litronic
- ⁴⁾ Ripper bucket with teeth size Z 20 P from R 934 Litronic

Note

When digging in highly abrasive materials, buckets must be protected by appropriate wear material. Optional side cutters with teeth 13 or 16 increase cutting width by approx. 120 mm.

- Weld-on set of adapters
- Set of bolt-on side cutters

Backhoe Attachment with 5,85 m Gooseneck Boom

Standard Equipment

Undercarriage

- Two-stage travel motors
- Lifetime lubricated track rollers
- Idler protection
- Track guide at each track frame
- Tracks sealed and greased

Upper carriage

- Engine hood with lift help
- Lockable tool box
- Handrails, non slip surfaces
- Tool Kit
- Maintenance-free swing brake lock
- Maintenance-free HD-batteries
- Sound insulation
- Mechanical swing lock upper/lower

Hydraulics

- Electronic pump regulation
- Stepless work mode selector
- Pressure storage for controlled lowering of attachments with engine turned off
- Hydraulic tank shut-off valve
- LSC control system
- Filter with integrated fine filter area (5 µm)
- Pressure test ports

Engine

- Direct injection
- Turbo charger
- Dry-type air cleaner w/pre-cleaner, main and safety element
- Sensor controlled engine idling

Operator's Cab

- Deep drawn cab shell components
- All tinted windows
- Door with sliding, window
- All-round adjustable roof flap
- Rain protective shade for front window
- Washer and wiper
- 6-way adjustable cloth suspension seat
- Seat and consoles independently adjustable
- Removable handle for travel pedals
- Air conditioner
- Coat hook
- Dome light
- Sun visor
- Inside rear mirrors
- Radio installation prep-kit
- Cigar lighter and ashtray
- Removable custom floor mat
- Storage and Literature tray
- Digital instrumentation
- Digital instruments for oil temp. engine RPM and oil pressure
- Digital hour meter visible from outside

Attachment

- Cylinders with shock absorbers
- Sealed pivots
- Centralized lube points
- SAE split flanges on all high pressure lines
- Safety hook on bucket
- Y sealant between bucket and stick
- Work light on boom

Optional Equipment

- Track guides at sprocket and in center
- Conversion kit-Track B 60 to D 6 C
- Sprocket with dirt ejector
- Reinforced base-plate center-piece

- Electric fuel tank filler pump
- Foot pedal swing positioning brake
- Extended tool kit
- Customized colors

- Additional hydraulic circuits
- Bio-degradable hydr. oil
- Filter for secondary circuit

- Engine cold starting aid

- Removable lower section of front window
- AM/FM stereo radio w/cassette
- Air power seat adjustment
- Warning beacon
- Additional flood lights
- Ventilator
- Armored glass

- Safety check valves for hoist cylinder, high mounted
- Overload warning device
- Hydr. or mechanical quick change coupler
- Liebherr line of clams and grapples
- Quick disconnect hose couplers
- Special application buckets
- Hydr. lines, on stick, for clam operation
- Two-way selector valve for bucket/clam
- Bucket link holder f/clam application
- Customized colors

Options and/or special attachments, supplied by vendors other than Liebherr, are only to be installed with the knowledge and approval of Liebherr to retain warranty.

Additional safety guidelines for excavators fitted with a cab elevation

When operating an excavator with a cab elevation, observe the following safety instructions which complete the general safety information provided in the operation and maintenance manual for the machine.

- Keep ladders, footsteps, handles and handrail in clean condition and always free them from mud, oil, grease, ice, snow or any other obstacles.
- To guarantee an easy opening of the cab door in all weather conditions, coat the rubber seals around the door with silicon oil or talcum every two months and more often if necessary. Regularly grease the hinges and lock of the cab door as well the fixing device of the door in opened position.
During maintenance works, always wear safety glasses and proper protective clothes.
- To climb up or down the cab, the excavator must be parked on firm, flat and level ground and the uppercarriage must be swung so to align ladders and steps on upper and undercarriage.
- Face the excavator when climbing up and always hold on to the machine at three points, i. e. keep the contact with the access components at the same time with two hands and one foot or with one hand and the two feet.
- As soon as you can reach the handle of the door with your free hand unlock and open the door before climbing up any more .

Keep and guide the door all the way with your hand and lock it in its opened position, making sure it is securely fixed in this position, so it can not be slammed by the wind.

Take care to keep yourself apart from the slewing range of the door during the whole of its opening motion.

Some external influences, and especially the wind, may make the opening of the door uneasy.

- Go on climbing up, always holding yourself by three points, enter the cab and seat down to the seat.
If applying fasten the seat belt. Unlock the door using the unlocking lever and close the door holding it by the handle designed for this purpose.
Only thereafter lower the safety lever and start the machine.
- It is essential to have your seat belt fastened if you want to operate the machine with the cab door opened.
Should the belt be missing on your machine, so you must compulsorily get one installed before you start working with opened cab door.
- Before climbing down the cab, you must make sure the machine is parked on a flat, firm and level ground and the ladders and steps are aligned on upper and undercarriage.
- Then open the cab door and lock it in opened position and make sure it is securely fixed in this position.
Be aware of difficult weather conditions and anticipate their possible consequences. The wind for example could slam the cab door.
- If necessary unfasten the seat belt.
- Carefully begin climbing down, facing the machine and always holding the contact at three points, until you reach the height where you can close the cab door in the best conditions, keeping yourself apart from its slewing range and guiding it with the hand until closed.
If you want so lock the door and take away the key.
- Slowly and carefully go down to the floor.

CONTROL UNIT

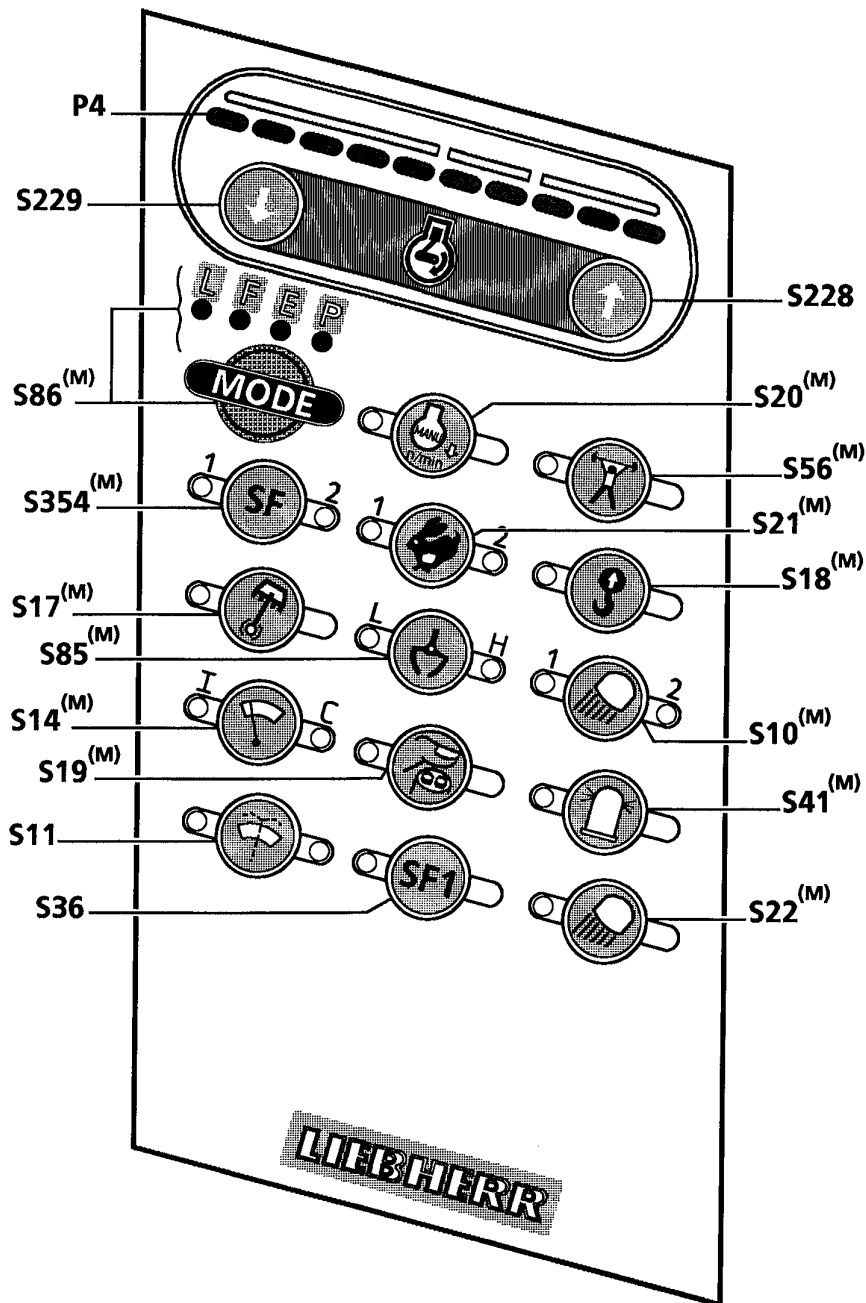

- P4 LED indicator for engine RPM
- S10 Lights on uppercarriage and working attachment
- S11 Windshield washer
- S14 Windshield wiper
- S17 Swing brake
- S18 Overload warning device *
- S19 Rotating device*
- S20 Automatic low idle
- S21 Travel speed increase
- S22 Auxiliary floodlights*
- S36 Special function - not used -
- S41 Beacon*
- S56 Pressure cut-in stage boom*
- S85 Grapple operation*
- S86 Operation mode selection
- S228 Engine RPM increase
- S229 Engine RPM reduce
- S354 Selection "Super Finish" for precision working

* Optional installation

(M) The function of the push buttons marked with (M) are memorized when stopping the excavator. This means that the controlled function recovers the previous state (on, off, 1/2, L/H, ...) before the machine had been turned off.

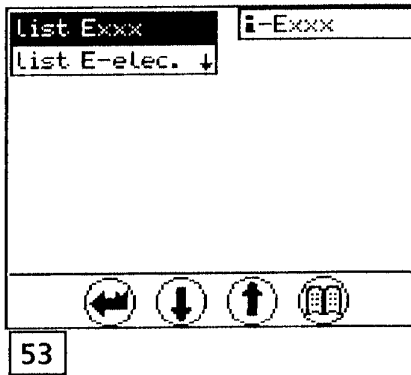

53

MENU **i-Exxx** ("i-errors")

INFORMATION ABOUT DETECTED ERRORS (OPERATING AND ELECTRICAL SYSTEM ERRORS)

In this menu (fig.53):

- select "list Exxx" to list all the operating errors detected by the switches and sensors for machine parameters monitoring (fig. 54),
- select "list S-Exxx", to show a listing of the above mentioned errors which occurred during service operation,
- select "list E-elec.", to show a listing of all the electrical errors (system errors) detected during operation of the machine,

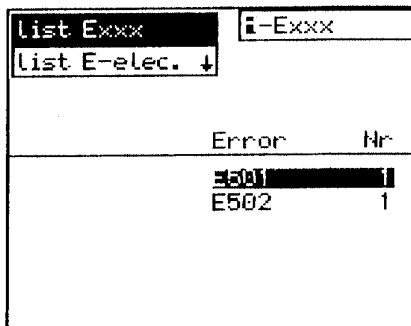

54

When selecting the operating errors "list Exxx" all the errors according to the list on pages no. 3.9 and 3.10 are listed, with error code and number of occurrence (fig. 54).

Move the arrow keys "UP" and "DOWN" to select the desired error.

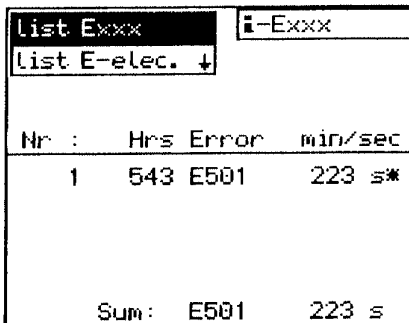

55

By pressing the "MENU" key, the overview of the selected error appears (fig. 55), with the indication of the operating hour and duration for the 10 first and the 10 last occurrences of the error.

Move the arrow keys "UP" and "DOWN" to page in this overview.

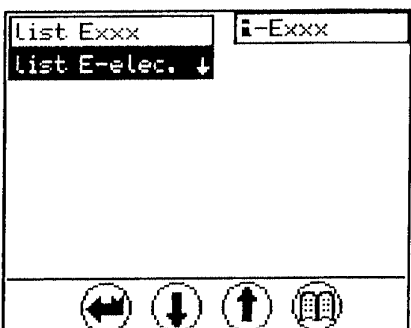

56

When selecting the electrical errors "list E-elec" all the system errors according to the list on page no. 3.11 are listed, with error code and number of occurrence (fig. 56 and 57).

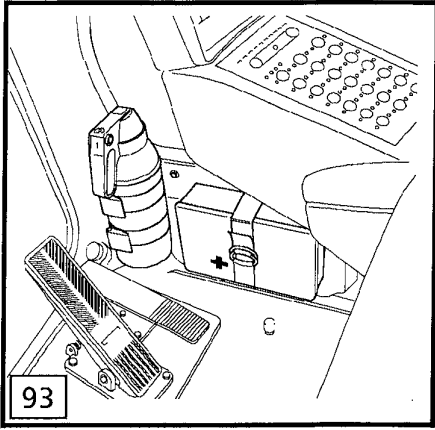

FIRE EXTINGUISHER / FIRST AID KIT*

Optional installation

The storage space for the fire extinguisher and the first aid kit is to be found at the bottom right of the operator's cab (fig. 93).

***Operator's prescription!**

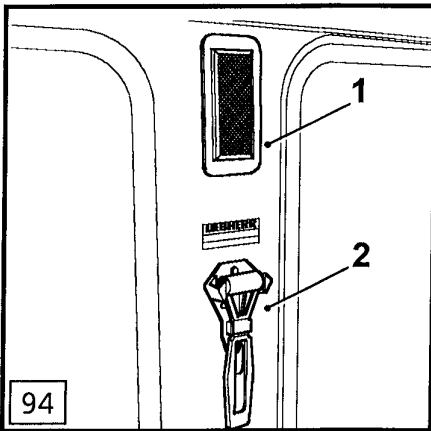

INTERIOR LIGHTING

The interior lighting (fig. 94, pos. 1) is switched on and off by pushing the lamp pane.

EMERGENCY HAMMER

The emergency hammer is located on the window, in the operator's cab (fig. 94, pos. 2).

In emergencies, one of the panels of the operator's cab can be smashed with it.

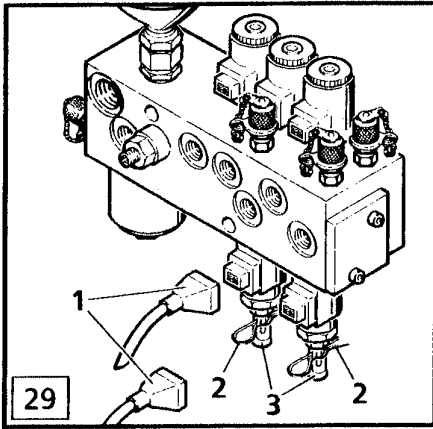

HYDRAULIC PUMPS SAFETY OPERATION

During normal operation of the excavator, the electronic horsepower control continuously adjusts the pumps flow to the pressure level of the working circuits.

If a trouble occurs in the circuit of the regulator, the pumps are swivelled back to minimal flow.

However, it remains possible in this case to carry on the working with the machine (with somewhat reduced pump power) by changing over the levers 3 on the servo oil unit which is mounted to the rear face of the hydraulic tank.

Disconnect both connectors 1, pull out the pins 2 and tilt the levers 3 in horizontal position (safety position).

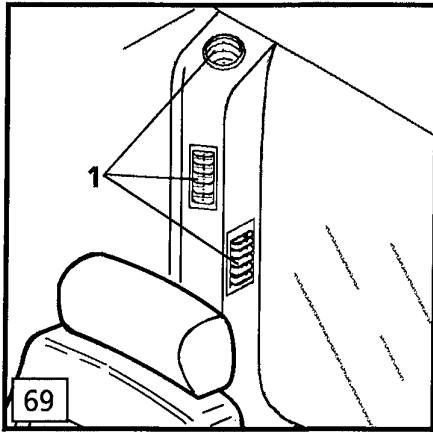

THE HEATER AND AIR CONDITIONER

As standard equipment the driver's cab is fitted with a heater and air conditioner unit (fig.76) which can be used for heating, cooling off and also as a fresh air ventilation for the cab.

CONTROL SWITCHES FOR HEATER AND AIR CONDITIONER (fig. 70)

- S92 Fresh air admission on / off
- S93 Adjustment of heating capacity
- S94 Adjustment of blower fan RPM
- S95 Air conditioner thermostat

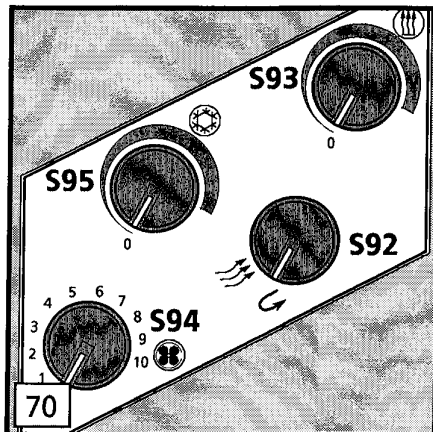

FRESH AIR VENTILATION

Turn the regulating knob S94 between position 1 and 10 to start the blower fan and adjust its RPM.

In position 0 the blower fan is turned off.

The fresh air enters the cab via the adjustable louvers 3 at the seat console, 2 at the instrument panel and 1 at the rear wall of the cab.

AMOUNT OF FRESH AND RECIRCULATED AIR

The heater and air conditioner can be operated with 100% recirculated air, but also with a mixing of fresh air (F) and recirculated air (R).

The knob S92 controls the flow of fresh air entering the cab:

- In position "recirculated air" the fresh air flap 7 (fig. 76) located in the rear cab wall is closed.
- In position "fresh air" this flap is open, and about 10% fresh air is admitted into the cab (depending on the contamination of the filters 4 and 5).

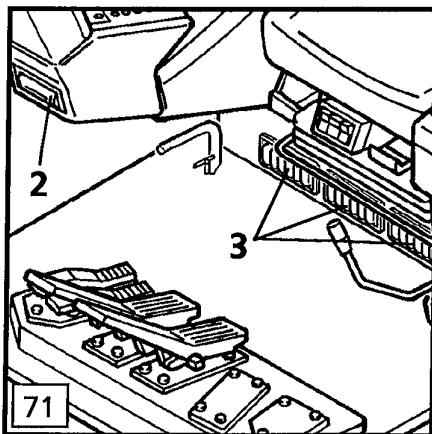

HEATER OPERATION

With the regulator S93 in position "0" the heating is off.

The heating of the cab is started when turning the knob to select the desired heating capacity (amount of warm water flowing through the heater).

If the heating is started with the blower fan knob S94 in position "0", the fan will automatically start with the lowest RPM (position 1 of S94).

AIR CONDITIONER OPERATION

With the thermostat S95 in position "0" the air conditioner is off.

To start the air conditioner, turn the thermostat to the desired room temperature (regulation range between 27 and 14 °C).

The electronic control system will turn the compressor on and off if required.

If the air conditioner is started with the blower fan knob S94 in position "0", the fan will automatically start with the lowest RPM (position 1 of S94).

CLICK HERE TO **DOWNLOAD** THE COMPLETE MANUAL

- Thank you very much for reading the preview of the manual.
- You can download the complete manual from: www.heydownloads.com by clicking the link below



- Please note: If there is no response to CLICKING the link, please download this PDF first and then click on it.

CLICK HERE TO **DOWNLOAD** THE COMPLETE MANUAL

INSTALLATION AND REMOVAL OF GRAPPLE TO STICK

INSTALLATION

Before installation of a two shell or multi shell grapple, make sure that all necessary hydraulic lines are installed on the stick.

If necessary, remove the bucket as described on page 4.24.

Retract the bucket cylinder all the way and turn the engine off.

Push the bracket carrier 8 between connector bracket 7 and push in right lever 9, secure with cotter pin 10.

Position the grapple with shells open. Start the engine and move the attachment until the lower bore holes of the stick fits between the bore holes of the grapple suspension.



DANGER

If another person is used as a guide during this installation procedure, the operator must follow the signals given by this person.

Engage the pin 4 in its bore and push in the pin bearing sealings 25 complete with protection ring while pressing in the pin (see also the corresponding section on page "Installation of a digging tool").

Secure the pin 4 with plate 6.

Connect the hydraulic hoses 11 and 12 for the shell cylinder to the hydraulic lines of the bucket cylinder circuit.

For grapple with hydraulic rotator, hoses 13 and 14 must be connected to the hydraulic lines for added functions on the stick.

Grapple operation:

Move the shut off lever on block 15 to position A to cut off the oil flow to the piston bottom side of the bucket cylinder.

Lubricate the different lube points on pin 4 and on the grapple mechanism.

Perform all attachment functions several times without load (open and close bucket, turn the grapple in both directions) to release air from the hydraulic system.

REMOVAL

Position the grapple with shells open on flat ground surface.

Turn the engine off, turn the ignition key to contact position and tilt the safety lever down, move the right joystick (for tilt cylinder) to the left and right, and release pressure in the hydraulic tank.

For grapple with hydraulic rotator, push also both buttons on the joystick to relieve the pressure in the swing circuit.

Disconnect the two hoses 11 and 12, and if present, the two hoses 13 and 14 from hydraulic lines on stick, and immediately close off open lines to prevent contamination.

Support the grapple properly.

Remove the plate 6. Drive out the pin 4 and remove the pin bearing sealings 25.

If necessary, start the engine and lift the attachment slightly to remove the pin 4.

To put the bucket cylinder back in operation, move the shut off lever in block 15 again to position B.



3) ENGINE COOLANT - Specifications for anticorrosion and antifreeze protection

Using a mixture of antifreeze and anticorrosion with "DCA 4" anticorrosion additive.

To assure the protection from corrosion of the cooling system, the coolant must contain at least 50% corrosion / antifreeze mixture all year round. This protects the cooling system to about - 35° C (- 33° F).

When fluid is added to the coolant mixture, it must be assured that the mixture maintains a 50% antifreeze content.

Caution : The percentage of antifreeze should not exceed 60 % . A higher concentration would lead to reduced antifreeze and cooling properties.

In addition, the cooling system must contain DCA4 (DCA = Diesel Coolant Additive) from FLEETGUARD. The prescribed concentration is from 0.3 to 0.8 DCA units per liter of coolant (1.2 to 3.0 units per US Gallon).

The coolant must be changed every 2 years. Before adding new coolant, check the circuit for cleanness and if necessary flush it with water.

Using a mixture of water and DCA4 (without antifreeze and anticorrosion)

In certain circumstances, and if ambient temperatures are constantly above the freezing point, for instances in tropical regions, and if there are no corrosion or antifreeze fluids available, then a mixture of water and DCA4 additives may be used.

To maintain sufficient anticorrosion properties however, the DCA4 concentration of the coolant must in this case be about doubled in comparison with the one prescribed when using a mixture also containing antifreeze and anticorrosion, it equals a concentration from 0.6 to 1.6 DCA units per liter of coolant (2.4 to 6.0 units per US Gallon) .

Important !

If employing a mixture consisting only of water and DCA4 additives :

- the use of coolant refiners (corrosion protective oils) is not authorized,
- the coolant change interval must be reduced to once a year.

Checking and maintaining the right DCA4 concentration in the cooling circuit

To check the DCA4 concentration, we recommend the use of the test kit CC 2602 M from FLEETGUARD (LIEBHERR order Nb 5608459).

The water filter mounted in the cooling circuit contains from 4 up to 8 DCA4 units, see the following schedule. When changing the filter, the corresponding units are added to the cooling circuit.

If there are no significant coolant leakages, regularly replacing the water filter every 500 working hours is sufficient to maintain the correct concentration of anticorrosive agent.

The DCA concentration has to be checked before each filter change, after each important coolant make up, and at regular intervals if smaller coolant quantities are refilled frequently.

If the concentration is too low, or when changing the coolant in the system, the remaining necessary DCA4 units must be added to the system in liquid form (see schedule).

The LIEBHERR order number for a 0,5 liter can containing 5 DCA4 units is 7363898.

Cooling system capacity (liter / US.Gallons)	DCA4-Water Filter			Quantity of DCA4 liquid(1)	
	Designation	LIEBHERR order nb	DCA4 units	0,5 liter cans	DCA4 units
24 - 39 / 6.3-10.4	WF 2071	7367045	4	3	15
40 - 59 / 10.5-15.7	WF 2072	7381493	6	4	20
60 - 79 / 15.8-20.9	WF 2073	7367052	8	5	25
80 - 115 / 21.0-30.4	WF 2073	7367052	8	8	40

(1) For use with a mixture containing 50% antifreeze and anticorrosion

Fresh water guidelines:

To mix the coolant fluid, only clean, preferably soft water should be used. Often, but not always, regular drinking water can be used. Sea water, brackish waters, sole water or industrial waste water may not be used.

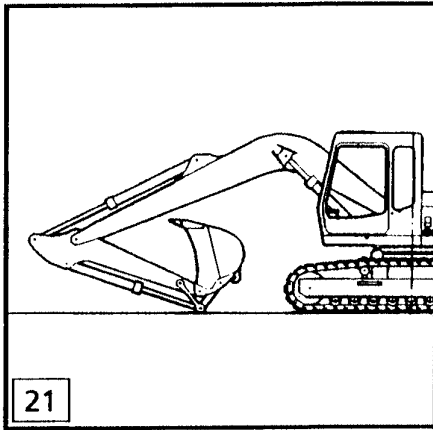

OIL IN THE HYDRAULIC SYSTEM

When checking the oil level or adding oil,

- Park the machine on level ground,
- rest the attachments on the ground with stick and tilt cylinders fully extended

CHECK HYDRAULIC OIL LEVEL

In this position the oil level may not drop below middle level on the sight gauge or oil must be added to the tank until reaching this level.

Level "MAXI" shows the maximum oil level when all cylinders are retracted.

Level "MINI" shows the minimum oil level when all cylinders are all the way extended.

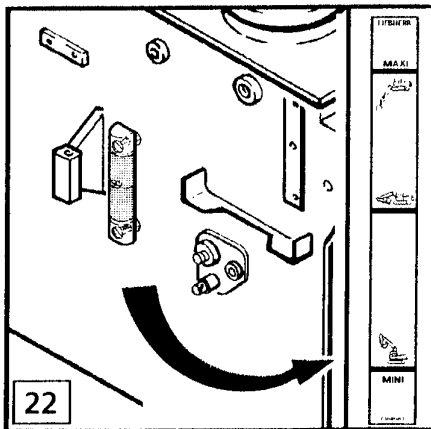

TO DRAIN AND TO ADD OIL TO THE HYDRAULIC TANK



CAUTION

Before draining the oil or opening the hydraulic tank, you always must first unscrew the breather filter 4 one turn to relieve tank pressure.

The hydraulic system should always be refilled or drained using a filler pump.

To drain oil

Remove the cover of the return filter 1 or the plug 2.

The oil must be drained via the two drain valves 5 and 6 in the bottom of the tank.

Attach a drain hose to the valves and suck off or let flow out the oil.

Adding oil to the tank

Unscrew the breather filter 4 one turn.

Add the oil via the filter cover 1 or via the plug 2 in the manhole cover, until the oil level reaches middle level on the sight gauge.

Close the breather filter.

Add some more oil to fill the tank up to the top. If refilling through the opening of the filter cover 1, pay attention to refill also the return oil compartment R (fig. 26) around the filter centering tube 7 completely.

Reinstall the filter cover 1 or the plug 2.

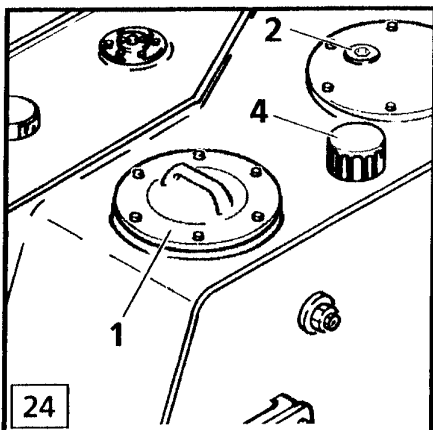
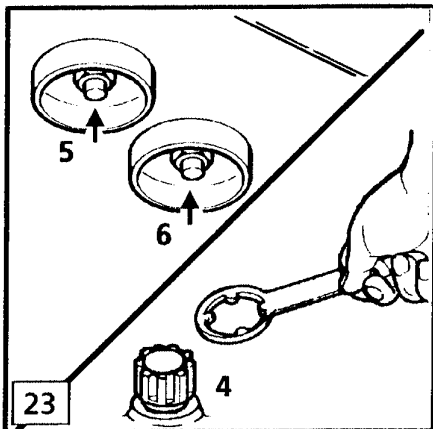

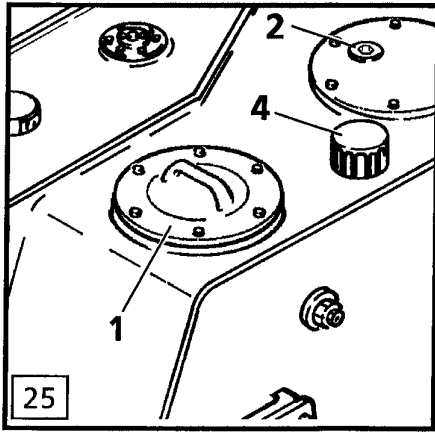

THE HYDRAULIC SYSTEM

Maintenance of the hydraulic system is limited to the hydraulic tank.

None of the other components in the hydraulic system require special maintenance.

However, hydraulic lines and hoses must be regularly checked for leaks.

Cleanliness in the hydraulic system is especially important.

For this reason, the given maintenance intervals to replace the return filter, to clean the oil cooler, and to change the oil need to be strictly observed.



DANGER

DO NOT ALLOW YOUR SKIN TO COME INTO CONTACT WITH HOT OIL OR COMPONENTS CONTAINING HOT OIL.

At or near operating temperature, engine and hydraulic oil is hot and can be under pressure.

Always relieve the hydraulic pressure before working on the hydraulic system.

Apply both joysticks (with ignition key in contact position) and then unscrew breather filter (Fig. 29, pos 4) one turn to depressurize the hydraulic tank.

OIL COOLER

A clean oil cooler is necessary to achieve optimum hydraulic oil cooling.

Clean the cooling circuit with air or steam at the intervals specified in maintenance schedule, and more often if the working conditions make it necessary.

RETURN FILTERS

The magnetic rod in the return filter (Fig. 28, pos. 2) should be cleaned daily during the first 300 operating hours, then every week.

Change fibre glass filter element 5 after the first 500 and 1000 operating hours.

Further changes of this element

- every 1000 operating hours,
- and with every occurrence of damage caused by contamination of the hydraulic system.

Notice : When working under very dusty conditions observe the special recommendations concerning the element change on page 5.9.

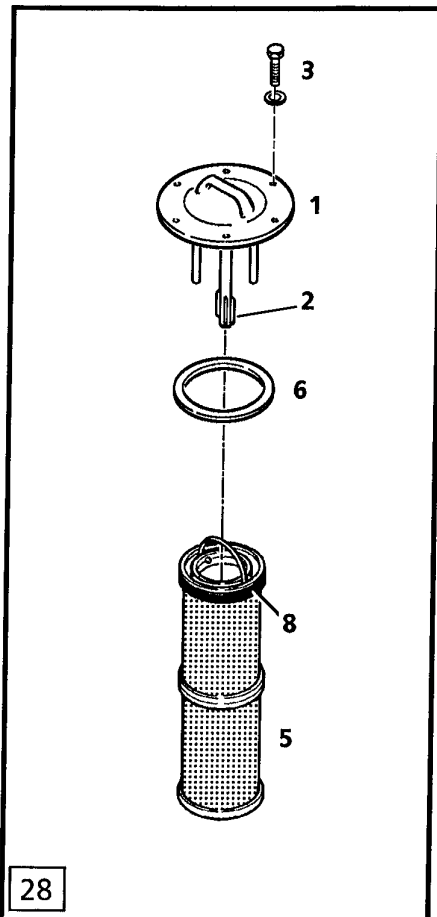

THE HEATER AND AIR CONDITIONER

HEATER AND AIR CONDITIONER UNIT

Remove and clean the recirculated air filter 4 and the fresh air filter 5 of the air conditioner unit every 500 working hours and more often in very dusty conditions.

If the filters are contaminated, the air flow through the exchangers is reduced, this causing frequent icing and stop of the airco plant.

Blow out the filter elements with pressure air, or clean them in cold or lukewarm water. Never wash the elements with warm water or using a steam jet. Filter elements which are damaged or in bad condition must be replaced at once.

Never operate the machine, even for a short time when the filters are removed, this would cause a very quick clogging of the heat exchangers of the unit.

To remove the recirculated air filter 4, tilt the backrest of the driver's seat forward and turn both quick locks (pos.2, fig. 65) by 90 degrees.

The fresh air filter 5 is accessible from the outside of the cab, after removal of the deflector 6 (fig. 66).

Once a year check for damage the lamellas of the heat exchanger 9 (evaporator and heater unit) and in case of clogging blow the exchanger out with pressure air . If necessary put the lamellas straight.

Heater circuit

The following maintenance should be performed annually before the beginning of the cold season:

- check the heater water circuit for leaks,
- check and if necessary retighten all connections, hose clamps and the seals on the water valves,

The heater should only be used with a DCA4 antifreeze and anticorrosive mixture.

When changing the engine coolant, close the heater valves on the engine (fig. 67). Otherwise the heater core must be vented correctly after refilling the circuit.

To vent the circuit, remove the red cap at bleeder valve through the opening A (fig.65), press the valve to let the air escape.

In addition, annually before the beginning of the cold season, and at least if insufficient heating is noticed, remove and clean the solenoid valve Y46 (fig. 68) which controls the warm water flow.

Clean the membrane of the solenoid valve with clear water and check that the compensation orifice at the membrane is not clogged.

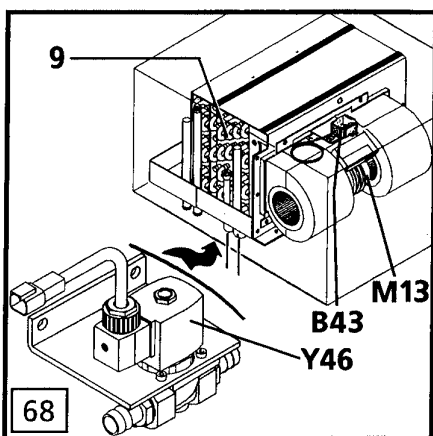
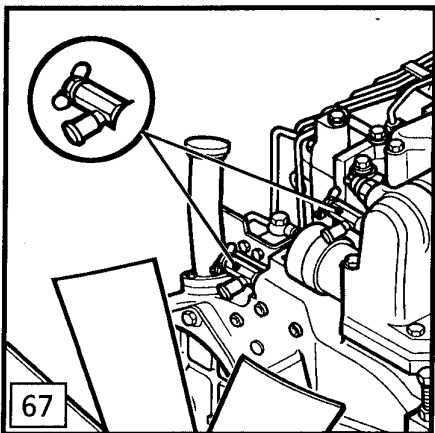
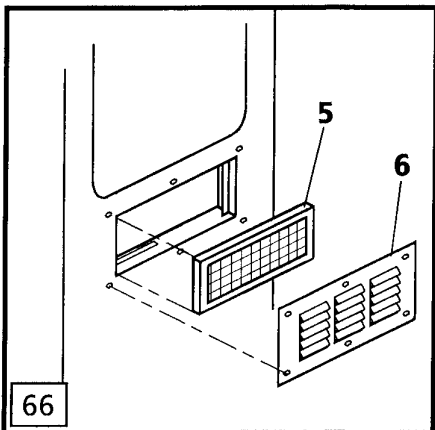
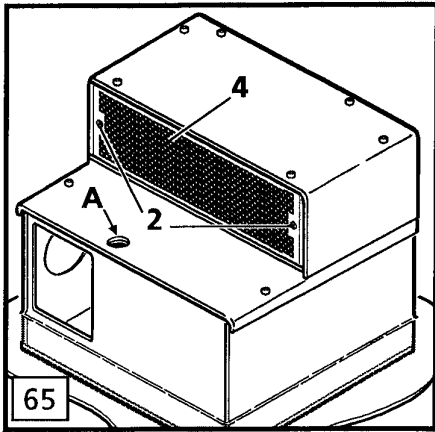

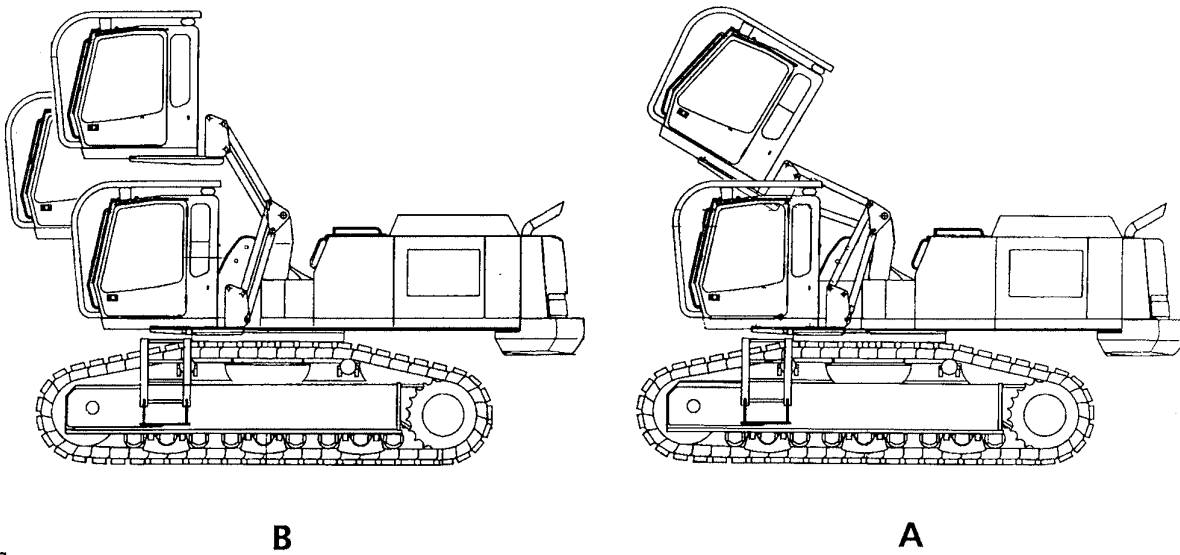
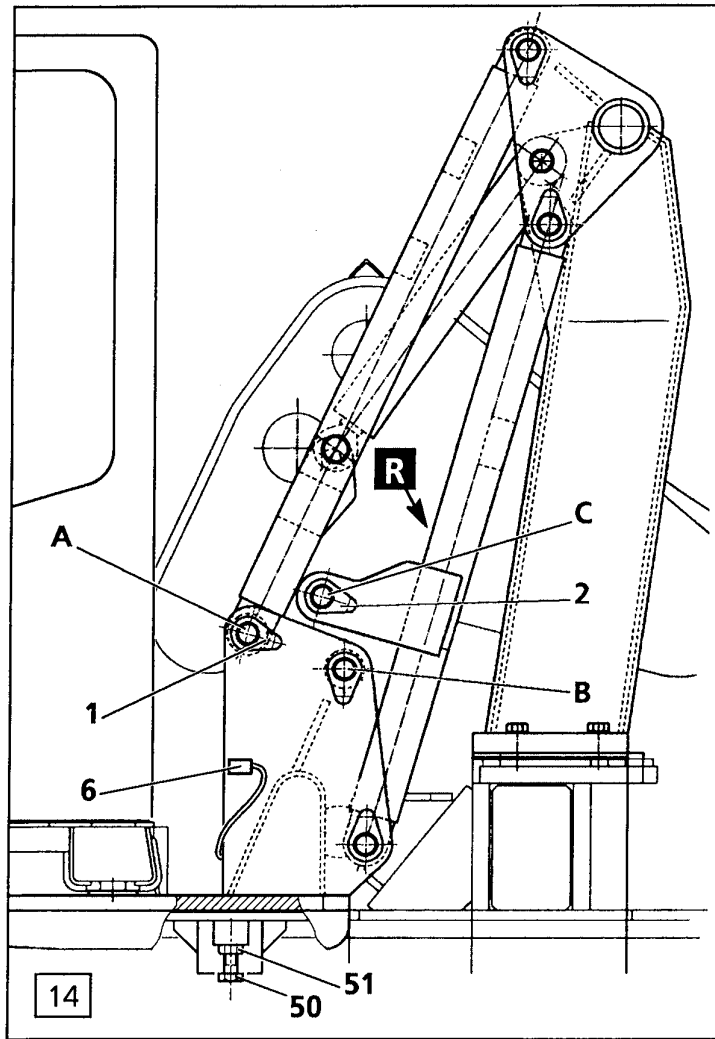

16

CLICK HERE TO **DOWNLOAD** THE COMPLETE MANUAL

- Thank you very much for reading the preview of the manual.
- You can download the complete manual from: www.heydownloads.com by clicking the link below



- Please note: If there is no response to CLICKING the link, please download this PDF first and then click on it.

CLICK HERE TO **DOWNLOAD** THE COMPLETE MANUAL