

Operation and Maintenance Manual

GALEO PC300LL-7EO

LOGGING EXCAVATOR

SERIAL NUMBERS **PC300LL-7EO** **A86001** and UP

This material is proprietary to Komatsu America Corp. and is not to be reproduced, used, or disclosed except in accordance with written authorization from Komatsu America Corp.

It is our policy to improve our products whenever it is possible and practical to do so. We reserve the right to make changes or add improvements at any time without incurring any obligation to install such changes on products sold previously.

Due to this continuous program of research and development, periodic revisions may be made to this publication. It is recommended that customers contact their distributor for information on the latest revision.

CLICK HERE TO **DOWNLOAD** THE COMPLETE MANUAL

- Thank you very much for reading the preview of the manual.
- You can download the complete manual from: www.heydownloads.com by clicking the link below



- Please note: If there is no response to CLICKING the link, please download this PDF first and then click on it.

CLICK HERE TO **DOWNLOAD** THE COMPLETE MANUAL

ENGINE SERIAL NUMBER PLATE

The engine serial number is located on the upper side of the engine valve cover.

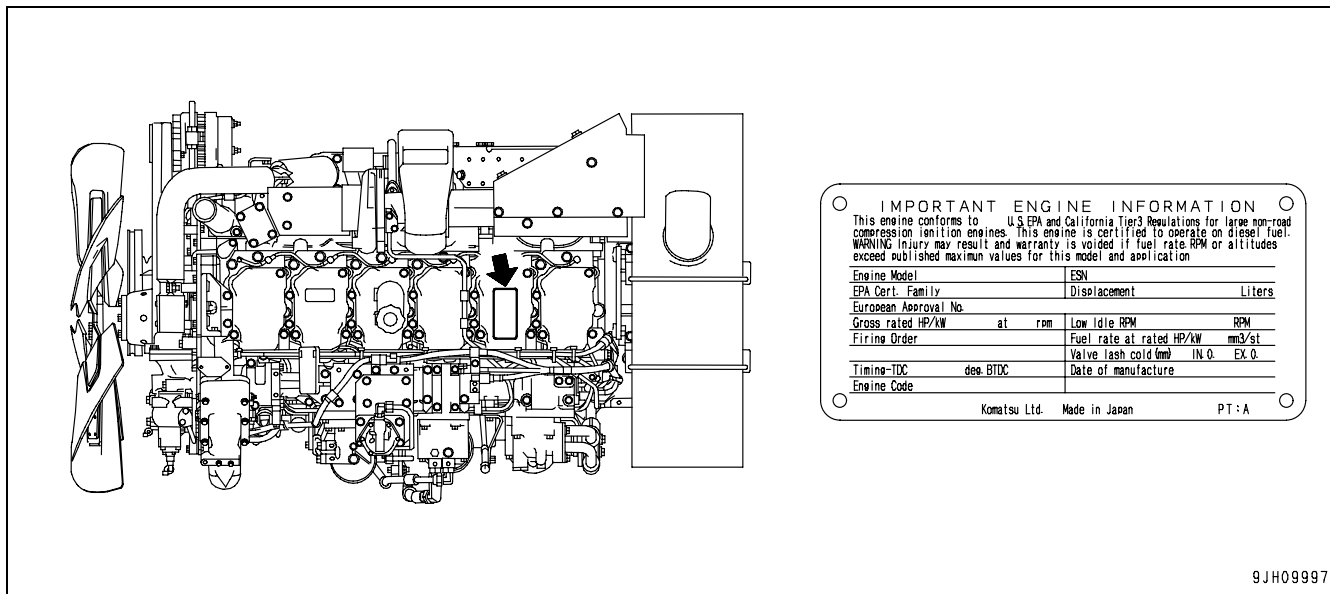

EPA: Environmental Protection Agency, U.S.A.

SERVICE METER LOCATION

On top of the machine monitor

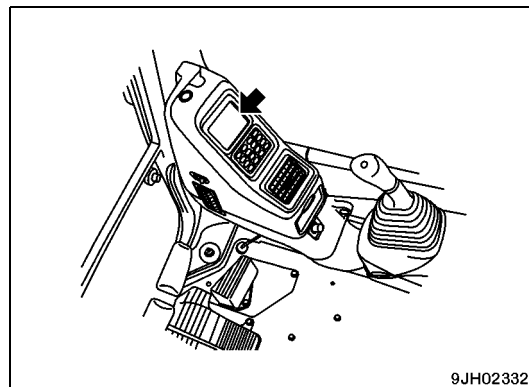

TABLE OF CONTENTS

RELEASING PRESSURE IN HYDRAULIC CIRCUIT	3-72
CHECK ALTERNATOR, STARTING MOTOR	3-73
CHECK ENGINE VALVE CLEARANCE, ADJUST	3-73
CHECK VIBRATION DAMPER	3-73
EVERY 4000 HOURS MAINTENANCE	3-74
CHECK WATER PUMP	3-74
REPLACE ACCUMULATOR (FOR CONTROL CIRCUIT)	3-75
CHECK HIGH-PRESSURE PIPING CLAMP, HARDENING OF RUBBER	3-76
CHECK FUEL SPRAY PREVENTION CAP, HARDENING OF RUBBER	3-76
EVERY 5000 HOURS MAINTENANCE	3-77
CHANGE OIL IN HYDRAULIC TANK	3-77
EVERY 8000 HOURS MAINTENANCE	3-78
REPLACE HIGH-PRESSURE PIPING CLAMP	3-78
REPLACE FUEL SPRAY PREVENTION CAP	3-78

SPECIFICATIONS

SPECIFICATIONS	4-2
DIMENSIONS	4-2
WORKING RANGE	4-6
ROAD BUILDER	4-6
LOG LOADER	4-8
LIFTING CAPACITY	4-10

OPTIONS, ATTACHMENTS

GENERAL PRECAUTIONS	5-2
PRECAUTIONS RELATED TO SAFETY	5-2
PRECAUTIONS FOR ATTACHMENT REMOVAL AND INSTALLATION	5-2
PRECAUTIONS WHEN USING LARGE IMPLEMENTS	5-3
HANDLING BUCKET WITH HOOK	5-4
HOOK CONDITION	5-4
PROHIBITED OPERATIONS	5-4
COMBINATIONS OF WORK EQUIPMENT FOR PC300LC-7	5-5
SELECTION OF TRACK SHOES	5-6

UNIQUE SAFETY DECALS FOR LOG LOADER AND ROAD BUILDER EXCAVATORS

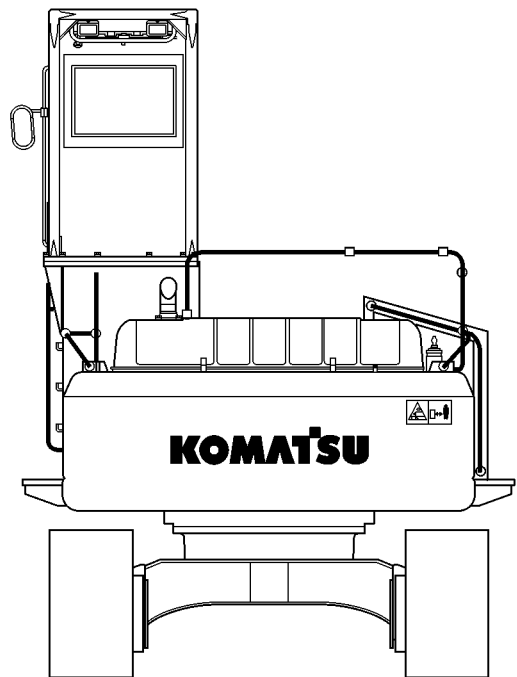
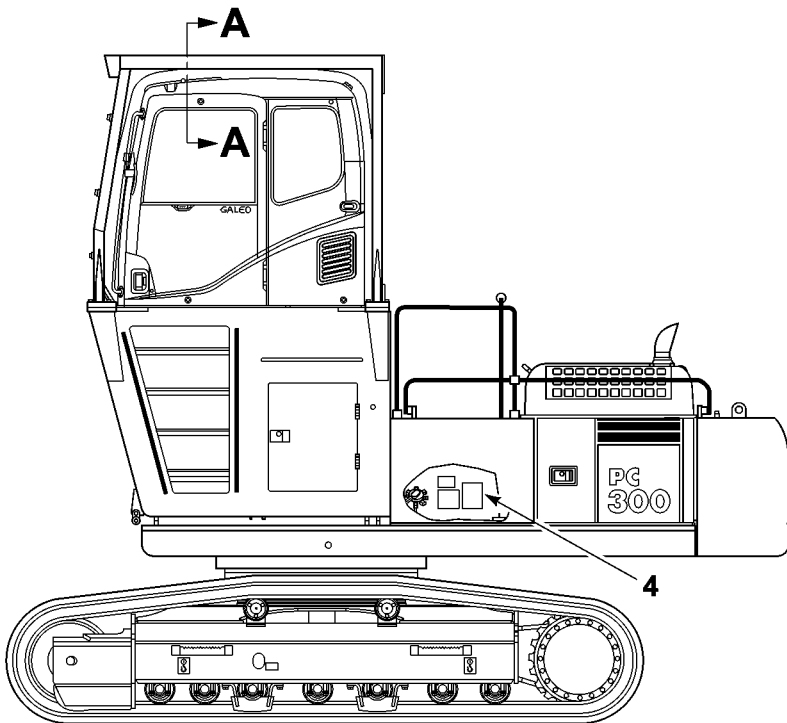
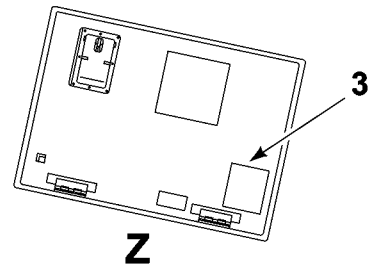
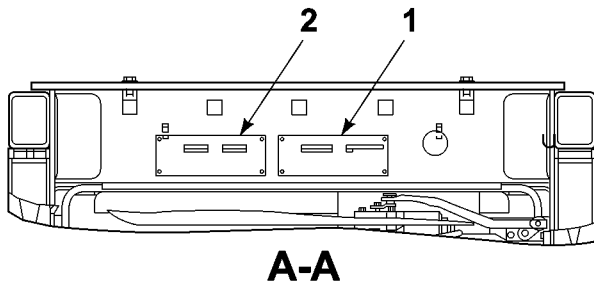

CM003470

ASBESTOS HAZARD ALERT

Asbestos or silica based dust in the air can cause lung cancer if they are inhaled. There is danger of inhaling asbestos or silica based materials when working on jobsites doing demolition work or handling industrial waste. Always observe the following.

- Spray water to keep down the dust when cleaning. Do not use compressed air for cleaning.
- If there is danger that there may be asbestos or silica based dust in the air, always operate the machine from an upwind position. All workers should use an approved respirator.
- Do not allow other persons to approach during the operation.
- Always observe the rules and regulations for the work site and environmental standards.

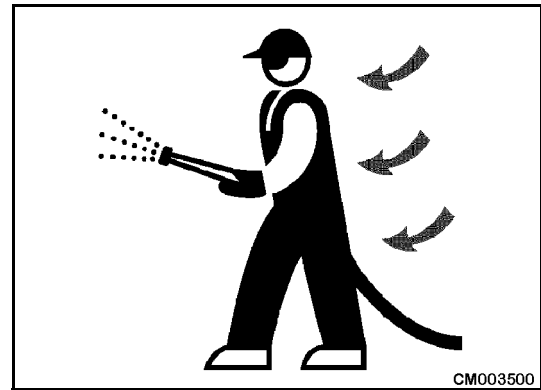

KEEP OPERATOR'S COMPARTMENT CLEAN

- When entering the operator's compartment, always remove all mud and oil from the soles of your shoes. If you operate the pedal with mud or oil on your shoes, your foot may slip and this may cause an accident.
- Do not leave parts or tools lying around the operator's compartment.
- Do not use cellular telephones inside the operator's compartment when driving or operating the machine.
- Never bring any dangerous objects such as flammable or explosive items into the operator's cab.

LEAVING OPERATOR'S SEAT WITH LOCK

- Before standing up from the operator's seat (such as when opening or closing the front window or roof window, or when removing or installing the bottom window, or when adjusting the operator's seat), lower the work equipment completely to the ground, set safety lock lever (1) securely to the **LOCK** position, then stop the engine. If you accidentally touch the control levers when they are not locked, there is a hazard that the machine may suddenly move and cause serious injury or property damage.
- When leaving the machine, always lower the work equipment completely to the ground, set safety lock lever securely to the **LOCK** position, then stop the engine. Use the key to lock all the equipment. Always remove the key, take it with you, and keep it in the specified place.

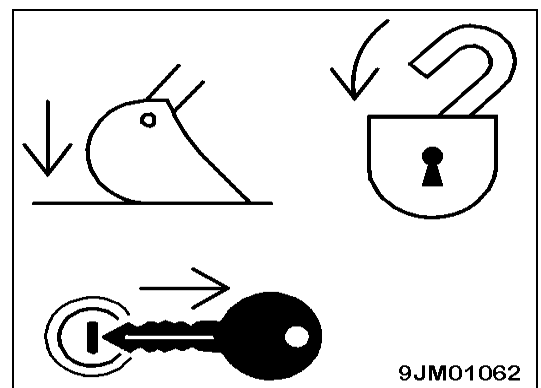
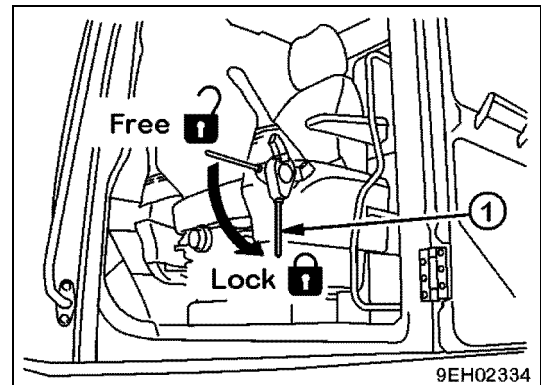

OPERATIONS ON SLOPES

When working on slopes, there is a danger that the machine may lose its balance and roll over when the swing or work equipment is operated. This may lead to serious injury or property damage, always provide a stable place when carrying out these type of operations, and work carefully. Do not swing the work equipment from the uphill side to the downhill side when the bucket is loaded. This operation is dangerous, and may cause the machine to tip over. If the machine has to be used on a slope, pile the soil to make a platform that will keep the machine as horizontal as possible.

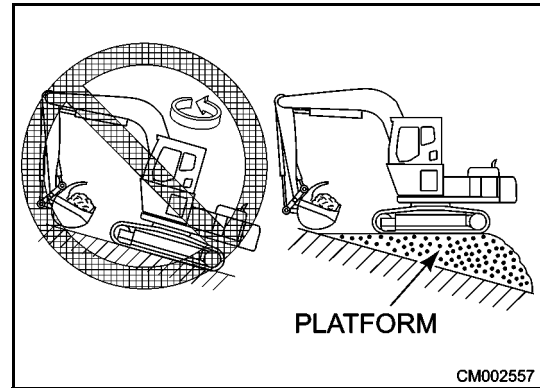

OPERATIONS ON SNOW

- Snow-covered or frozen surfaces are slippery, so be extremely careful when traveling or operating the machine, and do not operate the levers suddenly. Even a slight slope may cause the machine to slip, so be particularly careful when working on slopes.
- Frozen ground becomes soft when the temperature rises which may cause the machine to tip over.
- If the machine enters deep snow, it may tip over or become buried in the snow. Be careful not to leave the road shoulder or to get trapped in a snow drift.
- Be alert and careful when clearing snow. The road shoulder and objects buried in the snow beside the road may not be easily seen. The machine may hit covered objects and tip over.

RULES FOR REFUELING THE MACHINE

Always clean up any spills. Grease, fuel, oil or coolant spills can pose a trip hazard if not mopped up immediately.

Be sure you are adding the correct fluids to the proper location. Mixing fluids can cause damage to internal components.

When refueling or adding any fluids, be sure you are in a well ventilated area. Never smoke or allow open flames near you while you are refueling the machine.

Never mix gasoline with diesel fuel. Gasoline is extremely flammable and could cause an explosion. Do not fill the fuel tank completely, leave room for the fuel to expand.



COOLING SYSTEM PRECAUTIONS

Never add coolant to a hot or warm engine. Always allow the engine time to cool down completely before opening the radiator cap.

Never dump used coolant on the ground, in a lake, stream or in a sewer system. EPA Law requires these fluids to be captured and recycled properly. Failure to do so is in violation of the law.

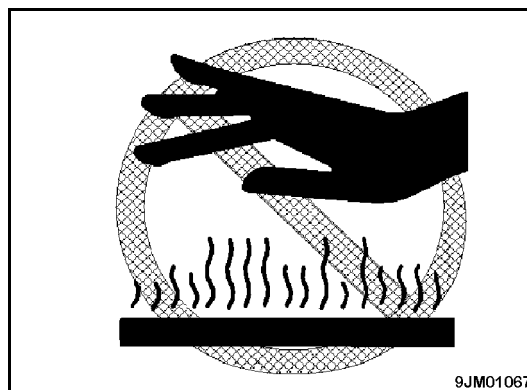

MACHINE MONITOR SYSTEM

The monitor system is the main control panel of the machine. This unit monitors all the functions relating to the machines operating system. It is important for the operator of this machine to study the monitor and become familiar with all these functions in order to achieve maximum performance from the machine. Failure to do so may lead to poor performance or premature failure of the machine.

MONITOR LAYOUT

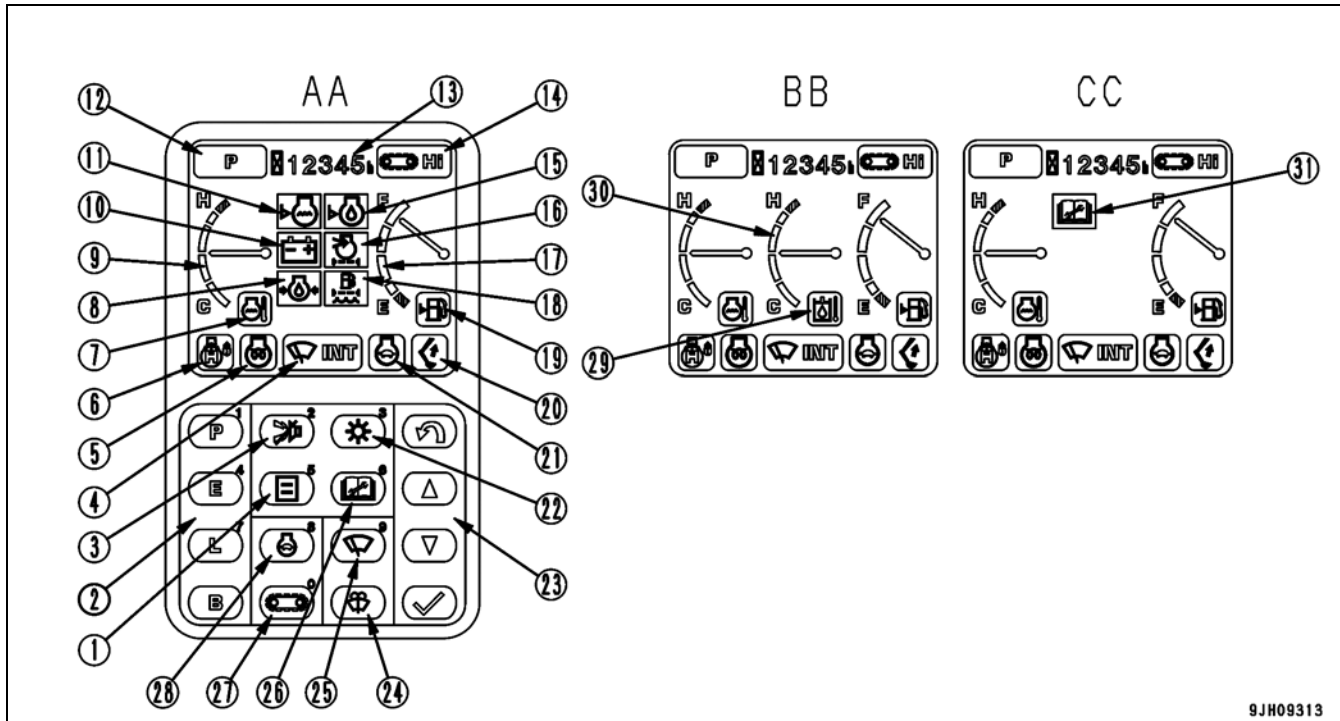

9JH09313

AA: Screen with all lamps lit

BB: Screen for normal operation

CC: Maintenance warning screen

- | | |
|---------------------------------------|--|
| 1. Selector switch | 17. Fuel gauge |
| 2. Working mode selector switch | 18. Water separator monitor |
| 3. Alarm buzzer stop switch | 19. Fuel level monitor |
| 4. Wiper switch | 20. One-touch power max. monitor |
| 5. Engine pre-heat monitor | 21. Auto-deceleration monitor |
| 6. Swing lock monitor | 22. Liquid crystal monitor adjustment switch |
| 7. Engine coolant temperature monitor | 23. Input control switch |
| 8. Engine oil pressure monitor | 24. Window washer switch |
| 9. Engine coolant temperature gauge | 25. Wiper switch |
| 10. Charge level monitor | 26. Maintenance switch |
| 11. Radiator coolant level monitor | 27. Travel speed selector switch |
| 12. Working mode monitor | 28. Auto-deceleration switch |
| 13. Service meter | 29. Hydraulic oil temperature monitor |
| 14. Travel speed monitor | 30. Hydraulic oil temperature gauge |
| 15. Engine oil level monitor | 31. Maintenance interval monitor |
| 16. Air cleaner clogging monitor | |

CHECK ALERTS

! WARNING

These monitors DO NOT ensure that the machine is in good condition. When performing checks before starting (daily checks), do not simply rely on the monitors. Always dismantle the machine and check each item directly.

Displays basic items among the check before starting items that must be checked before starting the engine. If there is any abnormality, monitor for the location of abnormality will light up.

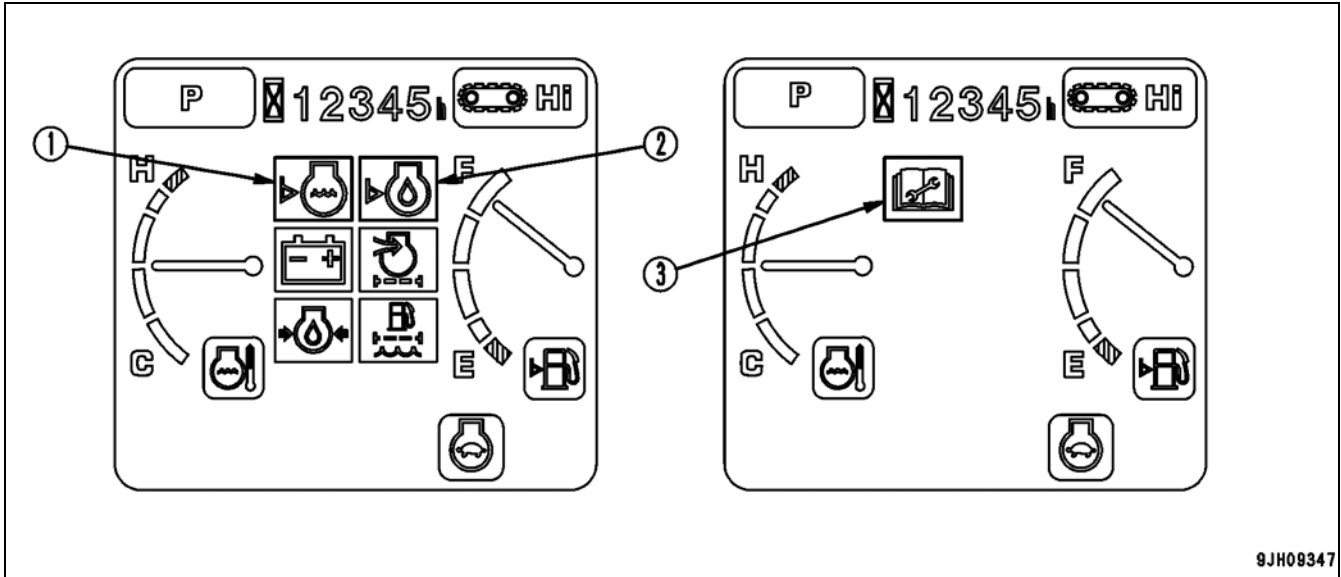

- 1. Coolant level monitor
- 2. Engine oil level monitor
- 3. Maintenance interval monitor

COOLANT LEVEL MONITOR

Monitor (1) warns the operator that there has been a drop in the radiator coolant level.

If the radiator coolant is low, the lamp lights up red, so check coolant level in the radiator and sub-tank, and add coolant.

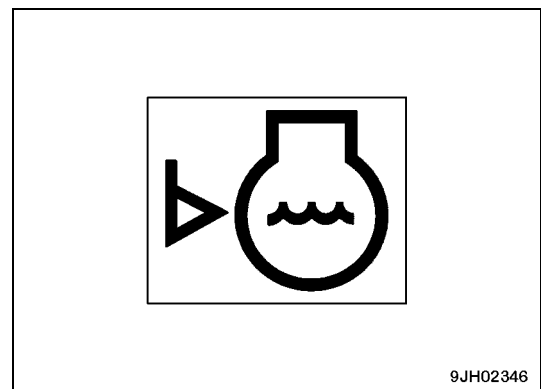

9JH02346

TRAVEL SPEED SELECTOR SWITCH

⚠ WARNING

- When loading or unloading from a trailer, always travel at low speed (with the travel speed selector switch (3) at the Lo position).
Never operate the travel speed selector switch (3) during the loading or unloading operation.
- If the travel speed is switched between high and low when the machine is traveling, the machine may deviate to one side, even when traveling in a straight line.
Stop the machine before switching the travel speed.

This switch (3) is used to set the travel speed to 3 stages.

- Lo lights up : Low-speed travel
- Mi lights up : Medium-speed travel
- Hi lights up : Hi-speed travel

When the engine is started, the speed is automatically set to Lo.

Each time that the switch is pressed, the display changes Lo → Mi → Hi → Lo in turn.

When traveling in high speed (Hi) or medium speed (Mi), if travel power is needed, such as when traveling on soft ground or on slopes, the speed automatically switches to low speed (Lo), there is no need to operate the switch. The monitor display (GG) stays at Hi or Mi.

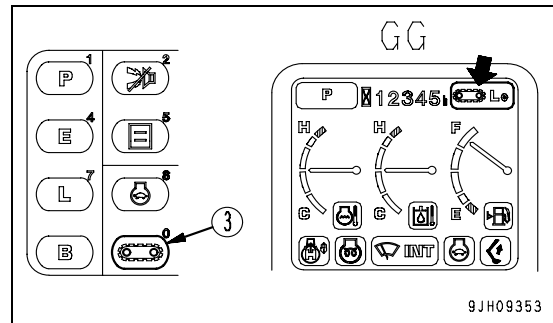

Remark

Each time that the travel speed selector switch is operated, the mode is displayed in the center of the monitor display portion (GG), and the screen (BB) returns to the normal screen after 2 seconds.

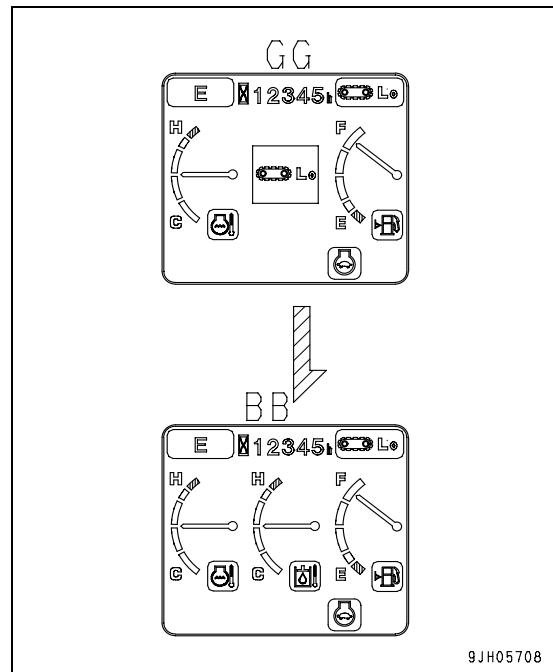

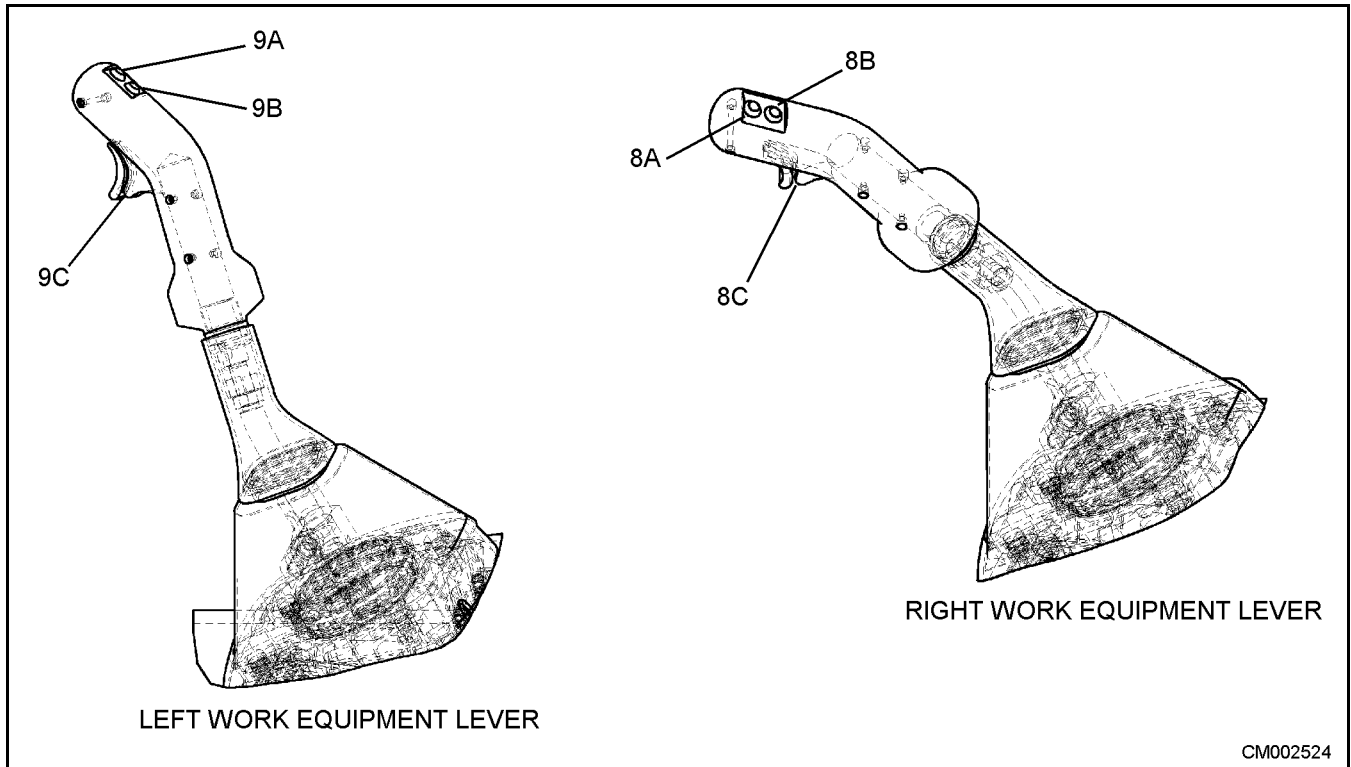

CM002524

8A. Horn Switch

8B. Log Loader Grapple Rotation CW or Road Builder an inactive switch

8C. Log Loader Grapple Close or Road Builder Thumb Close

9A. Power Max switch

9B. Log Loader Grapple Rotation CCW or Road Builder an inactive switch

9C. Log Loader Grapple Open or Road Builder Thumb Open

WINDOW SYSTEM

4. Grip knobs (A) at the top, bottom, left, and right of the front window, and pull lock lever (B) to release the lock at the top of the front window. The top of the front window will come out.

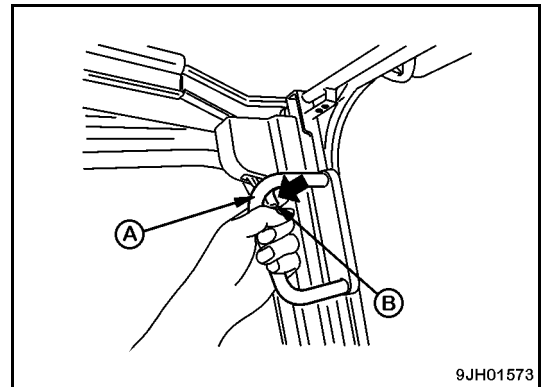
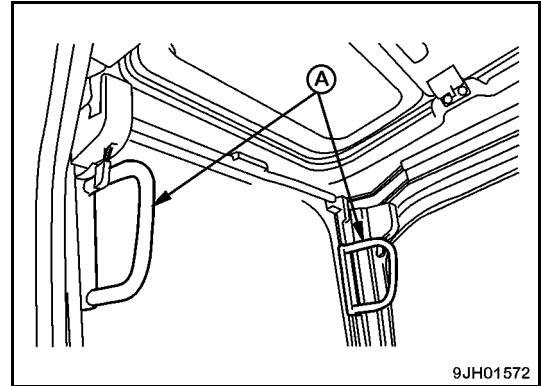

5. Hold lower knob (C) with your left hand from inside the operator's cab, and with your right hand, grip top knob (D)

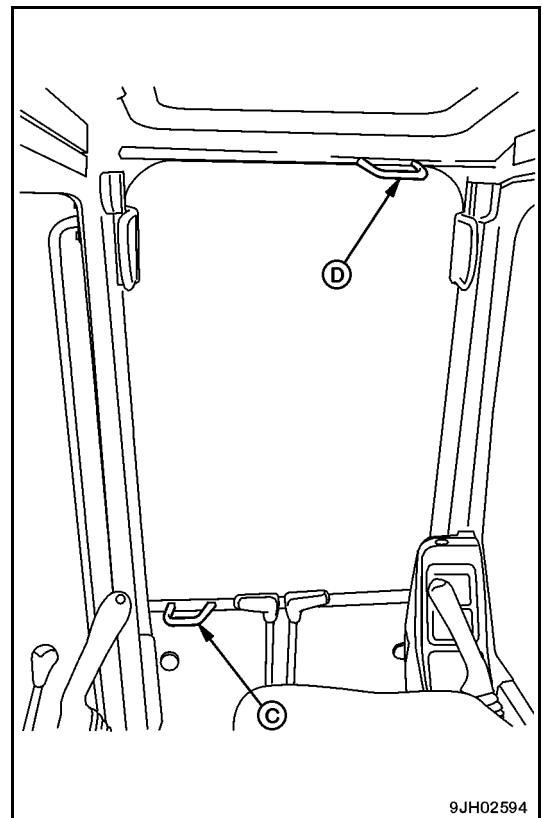

FAN SWITCH

This switch (2) is used to adjust the air flow.

The air flow can be adjusted to six levels.

- Press the ^ switch to increase the air flow; press the v switch to reduce the air flow.
- During auto operation, the air flow is automatically adjusted.

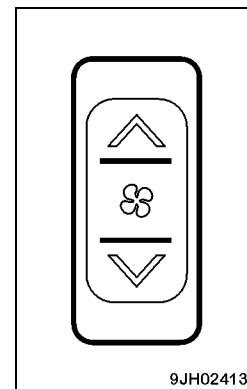

Monitor Display And Air Flow

Liquid crystal display	Air flow
	Air flow "low"
	Air flow "medium 1"
	Air flow "medium 2"
	Air flow "medium 3"
	Air flow "medium 4"
	Air flow "high"

TEMPERATURE SET SWITCH

This switch (3) is used to control the temperature inside the cab. The temperature can be set between 18°C (64.4°F) and 32°C (89.6°F).

- Press the ^ switch to raise the set temperature; press the v switch to lower the set temperature.
- The temperature is generally set at 25°C (77°F).
- The temperature can be set in stages of 0.5°C (0.9°F).

Monitor display and the function

Monitor display °C (°F)	Set temperature
18.0 (64.4)	Max. cooling
18.5 to 31.5 (65.3 to 88.7)	Adjusts temperature inside cab to set temperature
32.0 (89.6)	Max. heating

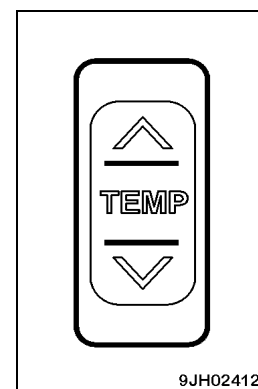

Remark

If the mode is set to auto mode and the temperature setting is set to 18.0°C (64.4°F) and 32.0°C (89.6°F), the air flow from the fan is always set to HIGH and does not change even when the set temperature is reached.

PRECAUTIONS WHEN USING AIR CONDITIONER

- When running the air conditioner, always start with the engine running at low speed. Never start the air conditioner when the engine is running at high speed. It will cause failure of the air conditioner.
- If water gets into the control panel or sunlight sensor, it may lead to unexpected failure, so be careful not to let water get on these parts. In addition, never bring any flame near these parts.
- For the auto function of the air conditioner to work properly, always keep the sunlight sensor clean and do not leave anything around the sunlight sensor that may interfere with its sensor function.

Ventilate the cab from time to time when using the cooler.

If you smoke when the cooler is on, the smoke may start to hurt your eyes, so open the window and carry out ventilation and cooling for a short time to remove the smoke.

When running the air conditioner for a long time, carry out ventilation and cooling together once each hour.

Be careful not to let the temperature in the cab get too low.

When the cooler is on, set the temperature so that it feels slightly cool when entering the cab 5 - 6°C (41 - 43°F) lower than the outside temperature). This temperature difference is considered to be the most suitable for your health. Adjust the temperature properly.

MAINTAIN MACHINE EQUIPPED WITH AIR CONDITIONER

When carrying out inspection of a machine equipped with an air conditioner, See “CHECK AND ADJUST AIR CONDITIONER” on page 3-37 and carry out inspection according to the table.

SELF-DIAGNOSTIC FUNCTION

It is possible to carry out troubleshooting of the various sensors and equipment used on the air conditioner.

1. Turn the ignition switch to the “ON” position
2. Press OFF switch (1). The temperature setting and air flow display on the liquid crystal display portion go out and operation stops.

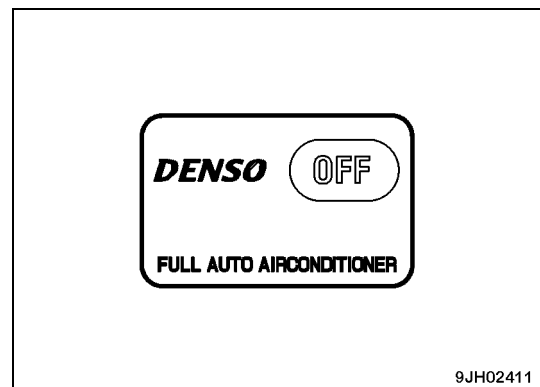
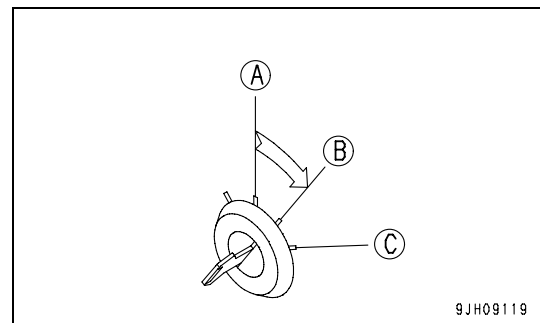

HANDLING THE ACCUMULATOR

WARNING

The accumulator is charged with high pressure nitrogen gas, so mistaken operation may cause an explosion which will lead to serious injury or damage. When handling the accumulator, always do as follows.

- The pressure in the control circuit cannot be completely removed. When removing the hydraulic equipment, do not stand in a position where the oil spurting out can strike you. Loosen the bolts slowly.
- Do not disassemble the accumulator.
- Do not bring it near flame or dispose of it in fire.
- Do not make holes in it or weld it.
- Do not hit it, roll it, or subject it to any impact.

When disposing of the accumulator, the gas must be released. Please contact your Komatsu distributor to have this work carried out.

The machine is equipped with an accumulator in the control circuit. The accumulator in the control circuit is a device to store pressure. When this accumulator is installed, it is possible to operate the control circuit for a short time even after the engine is stopped. Therefore, it is possible to lower the work equipment under its own weight by operating the control lever in the direction to lower the work equipment. The accumulator is installed in the position shown.

RELEASING PRESSURE IN CONTROL CIRCUIT

1. Lower the work equipment to the ground, then close the crusher or other attachment. Stop the engine.
2. Turn the key in the starting switch to the ON position again to let electric current flow in the circuits.
3. Set the safety lock lever to the free position, then operate the work equipment control levers and attachment control pedal backwards and forwards, and to the right and left to the full stroke to release the pressure in the control circuit.
4. Set the safety lock lever to the lock position to lock the control levers and attachment control pedal. Note that the pressure is not completely removed, so when removing accumulator (1) in the control circuit and accumulator (2) in the valve return circuit, loosen the bolts slowly and do not stand where the oil can strike you if it spurts out.

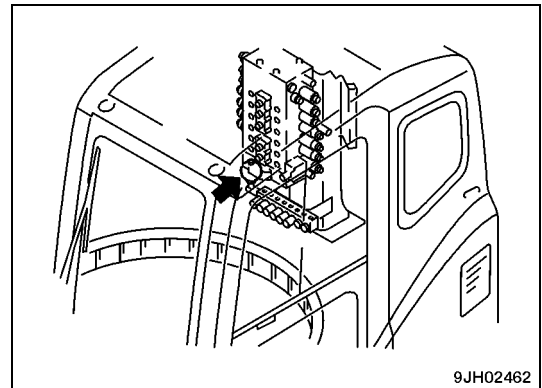

9JH02462

PRECAUTIONS BEFORE STARTING WORK

E: Overall fore and aft adjustment of seat

Move lever (7) to the right, set the seat to the desired position, then release the lever. In this case, the operator's seat, left and right control levers, and safety lock lever adjust together.

Fore and aft adjustment 120 mm

F: Adjusting suspension

Turn the knob (8) to the right to make the suspension harder, or to the left to make the suspension softer. Adjust the reading of the dial to match the operator's weight and select the optimum suspension.

Remark

To obtain the optimum adjustment, turn the knob (8) so that the indicator of the weight display (kg) in the transparent portion of knob (8) is the same as the operator's weight.

REAR VIEW MIRRORS

Mirrors A, B

Adjust the mirror mount so that it is possible to see people (or objects with a height of 1 m (3.3 ft) or a diameter of 30 cm (12 in))

at the rear left and right of the machine

If the movement of the mirror mount is stiff when adjusting the mirror, loosen mirror bolt (1) or (2).

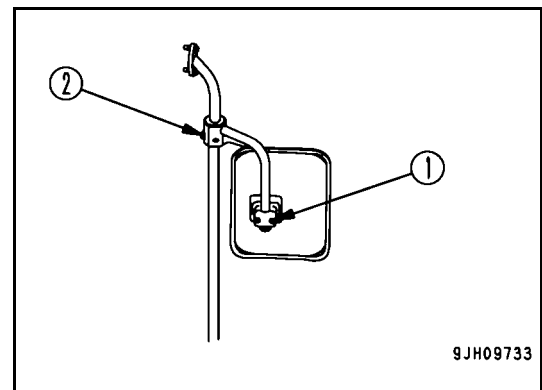

Mirrors D

Adjust so that it is possible to see the ground around the machine for 1 m from the operator's seat.

If the movement of the mirror is stiff when adjusting the mirror, loosen screw (3) of the mirror.

Install the mirror to the dimensions listed in the table below.

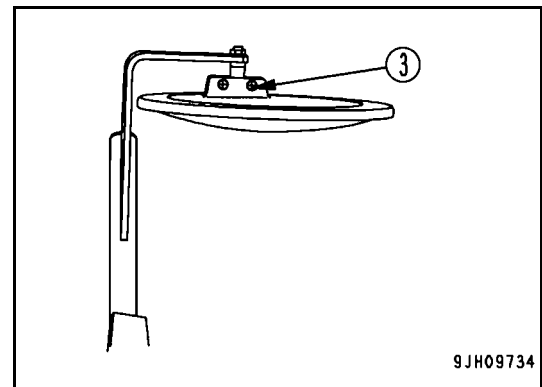

CLICK HERE TO **DOWNLOAD** THE COMPLETE MANUAL

- Thank you very much for reading the preview of the manual.
- You can download the complete manual from: www.heydownloads.com by clicking the link below



- Please note: If there is no response to CLICKING the link, please download this PDF first and then click on it.

CLICK HERE TO **DOWNLOAD** THE COMPLETE MANUAL

WARMING UP HYDRAULIC EQUIPMENT

WARNING

- Before carrying out the warming-up operation for the hydraulic equipment, turn the swing lock switch ON, check on the monitor that the swing lock is actuated, then start the warming-up operation.
- When warming up the hydraulic equipment, check to be sure there is no person or obstacle in the surrounding area, then sound the horn and start the operation.
- Carry out the warming-up operation for the hydraulic equipment until the hydraulic oil temperature monitor displays green.
- The warming-up operation for the hydraulic equipment is necessary not only for the circuit between the pump and cylinders and between the pump and motor, but also for all the control circuits. Do not carry out the operation just for one cylinder or motor, or the operation just in one direction. Carry out the operation in both directions for the work equipment (boom, arm, bucket), swing, travel, and attachment (if equipped).

1. Check to be sure engine water temperature monitor (1) displays green.

If it displays white, carry out additional warming up of the engine until engine water temperature monitor (1) displays green.

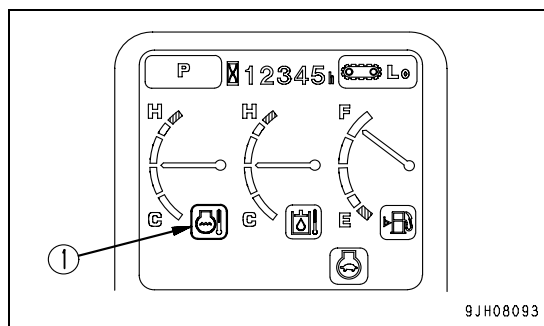

2. Turn swing lock switch (2) ON and check to be sure the swing lock monitor lights up.

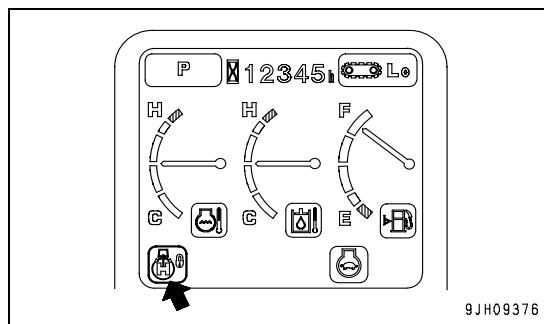

3. To complete the warming-up operation of the hydraulic equipment more quickly, set the working mode to P mode (heavy-duty mode).

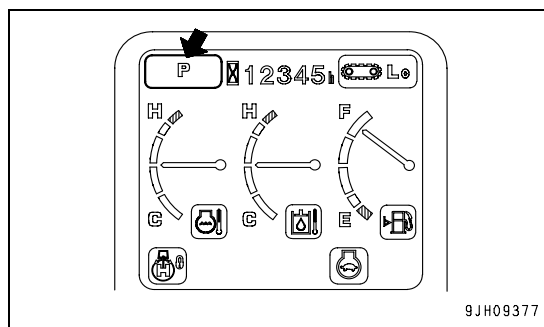

CHANGING DIRECTION OF THE MACHINE

When turning to the left:

If the left travel lever is returned to the neutral position, the machine will turn to the left.

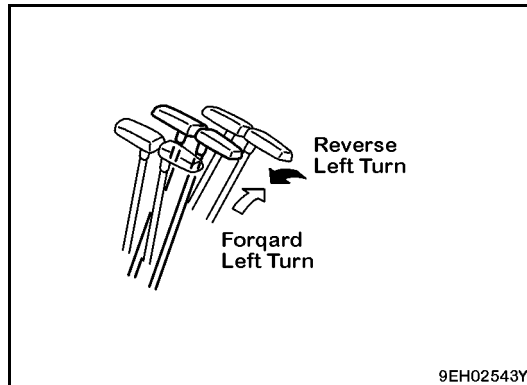

Remark

When turning to the right, operate the right travel lever in the same way.

(A): Forward left turn

(B): Reverse left turn

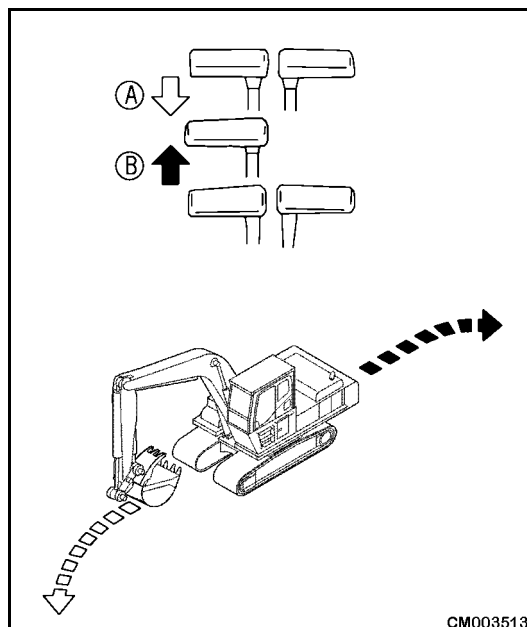

COUNTER-ROTATION TURN (SPIN TURN)

When using counter-rotation (spin turn) to turn left, pull the left travel lever back and push the right travel lever forward.

Remark

When using counter-rotation to turn right, pull the right travel lever back and push the left travel lever forward.

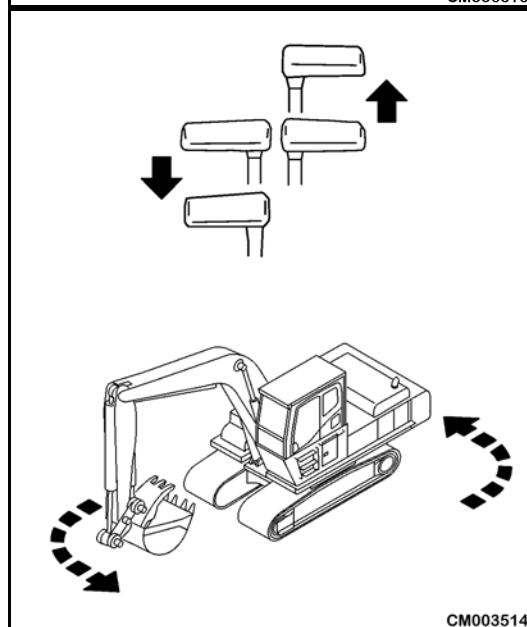

MACHINE INSPECTION AFTER DAILY WORK

BEFORE STOPPING ENGINE

Check the engine coolant temperature, engine oil pressure, and fuel level on the machine monitor.

Remark

After stopping the engine, if the ignition switch is turned within approximately 10 seconds to the ON or START position to start the engine again, the monitor display is not reset, and the screen before the ignition switch was turned OFF is displayed.

AFTER STOPPING ENGINE

Walk around the machine and check the work equipment, machine exterior, and undercarriage, also check for any leakage of oil or coolant. If any problems are found, repair them.

FILL THE FUEL TANK.

Check the engine compartment for paper and debris. Clean out any paper and debris to avoid a fire hazard.

Remove any mud affixed to the undercarriage.

Remark

Always remove the ignition key from the ignition switch, lock all lockable areas, lower the work equipment to the ground and neutralize controls.

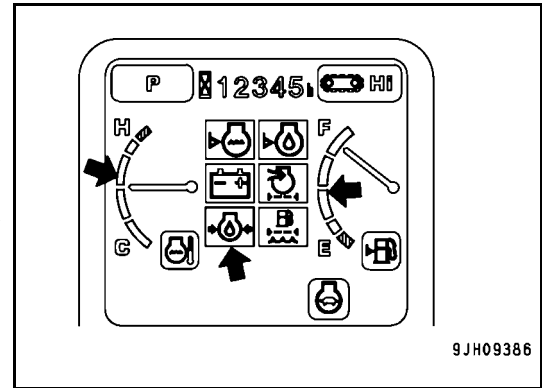

LOADING WORK

In places where the swing angle is small, work can be carried out more efficiently by stopping the dump truck in a place where it can be seen easily by the operator.

Loading is easier and the capacity is greater if you load from the rear of the dump truck body than if you load from the side.

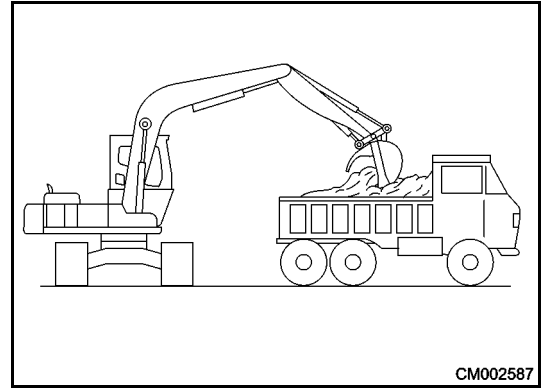

SEVERE JOB CONDITIONS

When carrying out digging operations in water, if the work equipment mounting pin goes into the water, carry out greasing every time the operation is carried out.

For heavy-duty operations and deep digging, carry out greasing of the work equipment mounting pins every time before operation.

After greasing, operate the boom, arm and bucket several times, then grease again.

MACHINES WITH CAB RISER

⚠ WARNING

The following procedure is for tilting a riser cab into its transportation position. This procedure is to be performed only after the machine is loaded onto its trailer and the engine is turned off.

Tilting of the riser cab is only for the purpose of transporting the machine and must not be used for any other purpose. Do not operate the machine with the cab riser bolts removed, or the cab partially or fully tilted.

Tilting of the riser cab is required to meet maximum height requirement when transporting the machine.

1. Open the cab riser door and secure with the door prop rod. Loosen and remove the six cab riser mounting bolts. Install the riser bolts into the bolt storage nuts. Do not over tighten the bolts, apply minimal torque with a wrench.

⚠ WARNING

Make sure the cab front window is securely in its closed position, remove any loose objects from the cab, close and securely latch the cab door, remove any loose objects from inside the riser, and close and securely latch the riser door. Failure to do any of these tasks can result in damage to the cab or riser and personal injury.

Do not stand in front of the cab and riser when tilting. Failure to do so can result in personal injury or death.

2. Turn the cab riser power disconnect switch located in the battery box to the ON position.
3. Open the left machine doors and move the cab tilt switch to the CAB TILT position.

Remark

The switch is a momentary switch and must be held in the CAB TILT position to activate the cab tilting process.

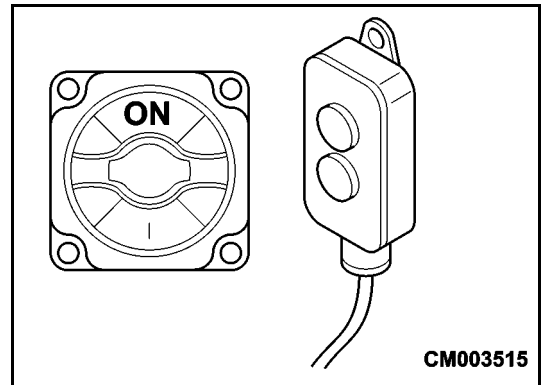
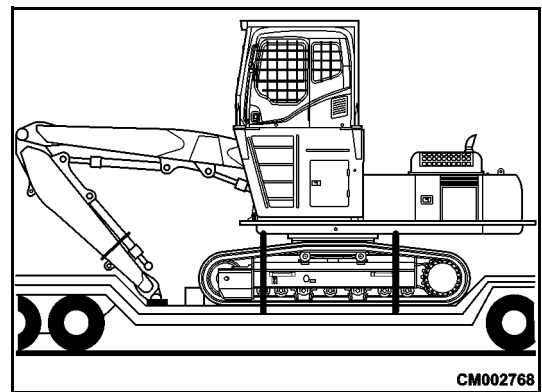
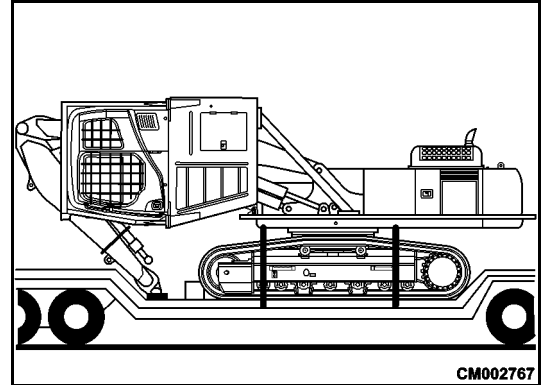

MONITOR

A feature of the liquid crystal monitor is that the screen becomes dark and is difficult to read in cold weather (particularly with the ignition switch ON).

In this case, adjust the brightness and contrast of the screen.

For details, See “BACK SWITCH” on page 2-31”.

If the screen is dark, increase the brightness and contrast (extend the scale in the +E direction) to make the screen brighter and easier to read.

- Brightness

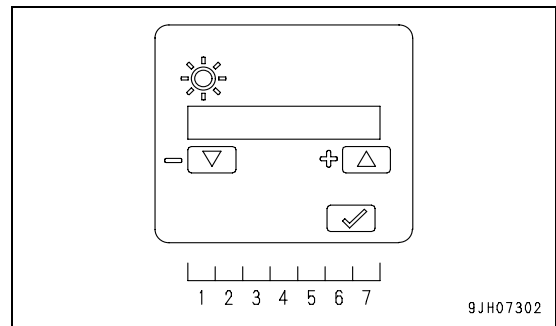

- Contrast
- Guideline for bar display for brightness and contrast in cold weather

Ambient temperature	Brightness	Contrast
-10°C (14°F)	7 (max)	5 - 4
-20°C (-4°F)	7	7 - 6

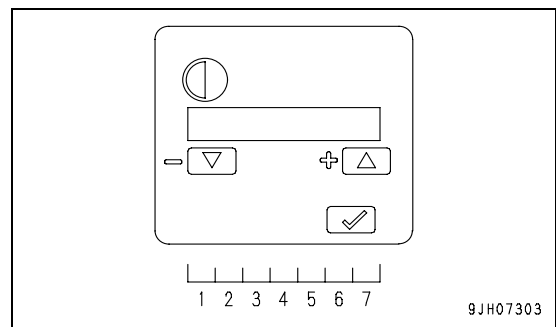

TELEPHONE WHEN ERROR OCCURS

If an error screen is displayed on the monitor, the screen changes as follows each time input confirmation switch (1) is pressed.

Error screen → screen A → screen B → screen C → error screen

Check the point of contact telephone number on screen B.

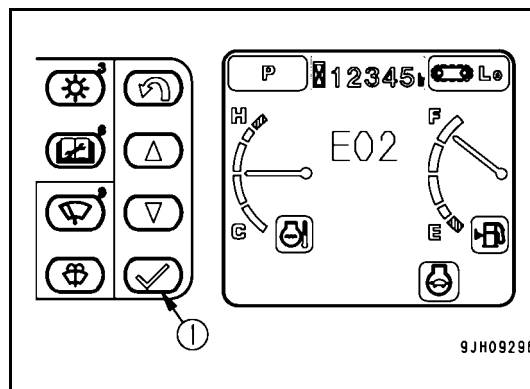

9JH09296

Remark

If the point of contact telephone number has not been registered, screen B is not displayed. If it is necessary to register the point of contact telephone number, ask your Komatsu distributor to register it.

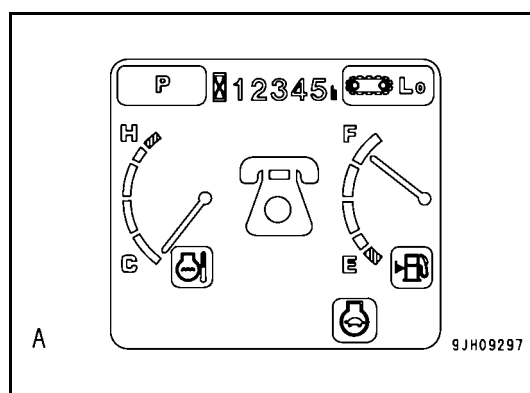

A

9JH09297

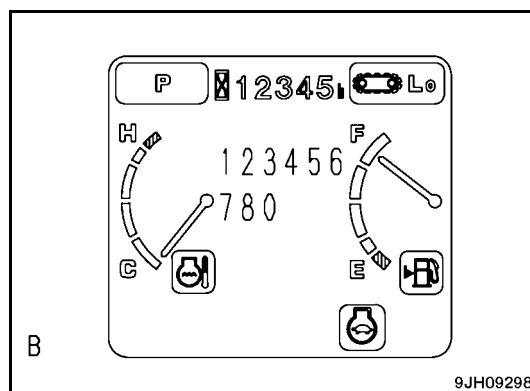

B

9JH09298

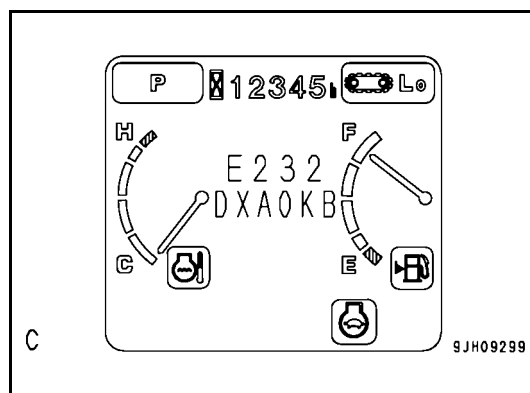

C

9JH09299

FILTERS

- Filters are extremely important safety parts. They prevent impurities in the fuel and air circuits from entering important equipment and causing problems.
Replace all filters periodically. For details, see the Operation and Maintenance Manual.
However, when working in severe conditions, replace the filters at shorter intervals according to the oil and fuel (sulfur content) being used.
- Never try to clean the filters (cartridge type) and use them again. Replace with new filters.
- When replacing oil filters, check if any metal particles are stuck to the old filter. If any metal particles are found, please contact your Komatsu distributor.
- Do not open packs of spare filters until just before they are to be used.
- Use Komatsu genuine filters.

ELECTRIC SYSTEM MAINTENANCE

- It is extremely dangerous if the electrical equipment becomes wet or the covering of the wiring is damaged. This will cause electrical leakage and may lead to malfunction of the machine. Do not wash the inside of the operator's cab with water. When washing the machine, be careful not to let water get into the electrical components.
- Minimum service relating to the electric system is a check of fan belt tension, check of damage or wear in the fan belt and check of battery fluid level.
- Never install any electric components other than those specified by Komatsu.
- External electrical interference may cause malfunction of the control system controller. Before installing a radio receiver or other wireless equipment, please contact your Komatsu distributor.
- When working at the seashore, carefully clean the electric system to prevent corrosion.
- When installing an operator's cab cooler or any other electrical equipment, connect it to an independent power source connector. The optional power source must never be connected to the fuse, ignition switch, or battery relay.

HANDLING HYDRAULIC SYSTEM

- During and after operations, the hydraulic system is at high temperature. During operations, it is also under high pressure, so pay careful attention to the following when carrying out inspection and maintenance of the hydraulic system.
- Stop the machine on level ground, lower the bucket to the ground, and set it so that there is no pressure on the cylinder circuit.
- Stop the engine.
- Immediately after operations, the hydraulic oil and lubricating oil are under pressure and at high temperature, so wait for the temperature to cool before starting maintenance.
- Even when the temperature cools, there may still be internal pressure. When loosening plugs, screws, or hose connections, do not stand directly in front. Loosen them gradually to release any internal pressure before removing.
- When carrying out inspection or maintenance of the hydraulic circuits, bleed the air to release the internal pressure.
- Minimal inspection or maintenance consists of checking the hydraulic oil level, replacing the filters, and changing the hydraulic oil.
- When removing high-pressure hoses, check to be sure the O-ring is not damaged. If it is damaged, replace it.

MAINTENANCE INTERVAL FOR HYDRAULIC BREAKER

For machine equipped with a hydraulic breaker, the hydraulic oil deteriorates faster than for normal bucket digging operations, so set the maintenance intervals as follows.

REPLACE HYDRAULIC FILTER ELEMENT

On a new machine, replace the element after the first 100 to 150 hours, then carry out further replacement of the element according to the table on the right.

CHANGE OIL IN HYDRAULIC TANK

Change the oil according to the table on the right.

REPLACING ADDITIONAL FILTER ELEMENT FOR BREAKER (IF EQUIPPED)

Use a guideline of 250 hours for use of the breaker (operating ratio for the breaker: 50% or more), and replace the element according to the table on the right.

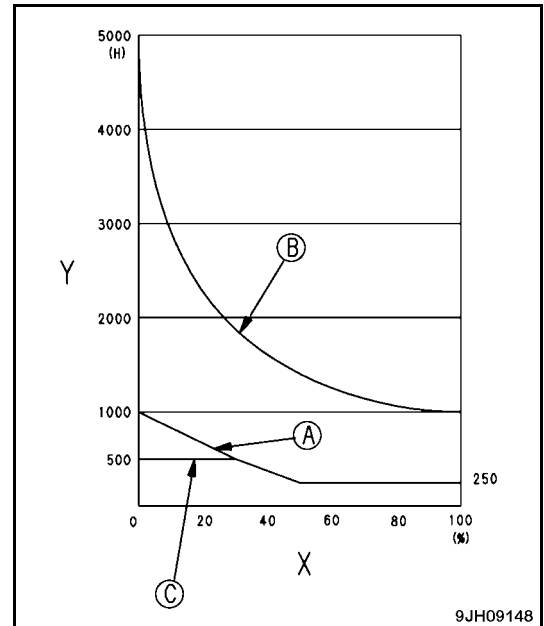

X: Breaker operating ratio (%)

Y: Replacement interval (H)

(A): Hydraulic filter element

(B): Hydraulic oil

(C): Additional filter element

Remark

Breaker operating ratio 100% means that only the breaker is used Breaker operating ratio 0% means that the breaker is not used

14. Stop the engine, wait for approximately 3 minutes, then add coolant until the coolant level is near the coolant filler port, and tighten the cap. Check the coolant level and add coolant if necessary.

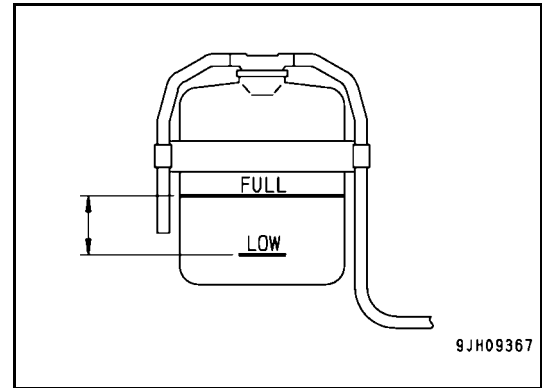

CHECK AND TIGHTEN TRACK SHOE BOLTS

If the machine is used with loose track shoe bolts (1), they will break, so tighten any loose bolts immediately.

TIGHTENING TRACK SHOE BOLTS

1. First tighten to a torque of 392 ± 39 Nm (289 ± 28 ft/lb) then check to be sure the nut and shoe are in close contact with the link contact surface.
2. After checking, tighten further $120^\circ \pm 10^\circ$.

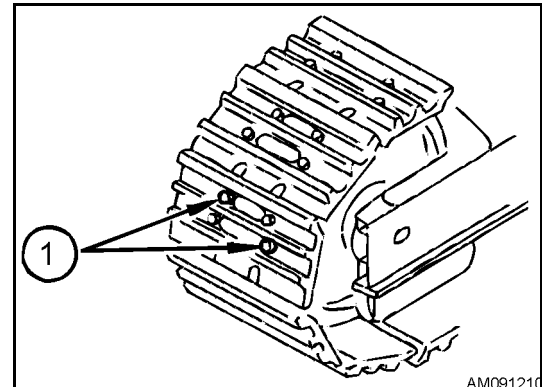

ORDER FOR TIGHTENING

Tighten the bolts in the order shown in the diagram on the right. After tightening, check to be sure the nut and shoe are in close contact with the link mating surface.

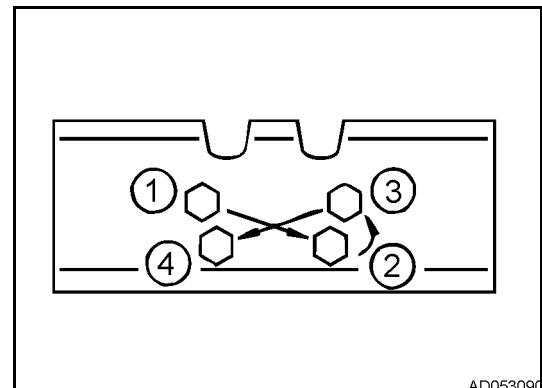

CHECK AND ADJUST AIR CONDITIONER

- For air conditioner service, contact your Komatsu dealer.

Inspection and maintenance items	Contents	Maintenance interval
Condenser	Clogging of fin	Every 500 hours
Compressor	Function	Every 4000 hours
V-belt	Damage and tension	Every 250 hours
Blower motor and fan	Function (Check for abnormal sound)	When required
Control mechanism	Function (Check for normal function)	When required
Piping for connection	Installation condition looseness of tightening connection portions gas leakage, damage	When required

Remark

Be careful when pressure washing the condenser fins, the high pressure water may damage the fins.

- When draining the oil, first pull hose (2) out from inspection hole (B), then turn the drain valve to the OPEN position.
6. After checking oil level or adding oil, insert the dipstick into the hole and install air bleeding plug (1).

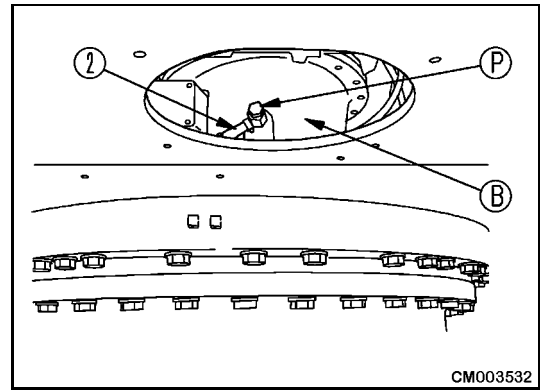

CHECK OIL LEVEL IN FINAL DRIVE CASE, ADD OIL

⚠ WARNING

The parts and oil are hot after the engine is stopped, and may cause serious burns. Wait for the temperature to cool before starting the operation.

If there is still pressure remaining inside the case, the oil or plug may fly out. Loosen the plug slowly to release the pressure.

- Prepare a hexagonal wrench.
1. Set the final drive so that **TOP** mark comes to the top and the mark and plug (P) are perpendicular to the ground.
 2. Using a hexagonal wrench, remove plug (F) and check to be sure the oil level is within a range from the bottom of the plug hole to a point 10 mm (0.4 in) below it.
 3. If the oil level is too low, install plug (F), operate the travel levers, and drive forward or in reverse to rotate the sprocket one turn. Then repeat Step 2 to check again.
 4. If the oil level is still too low, add engine oil through the hole in plug (F) until the oil overflows.
 5. After checking, install plug (F).

Torque for plugs: 68.6 ± 9.9 Nm (50.6 ± 7.2 ft/lb)

Remark

There are two plugs (F). Add oil through the one easier to fill and through which no internal gears are seen.

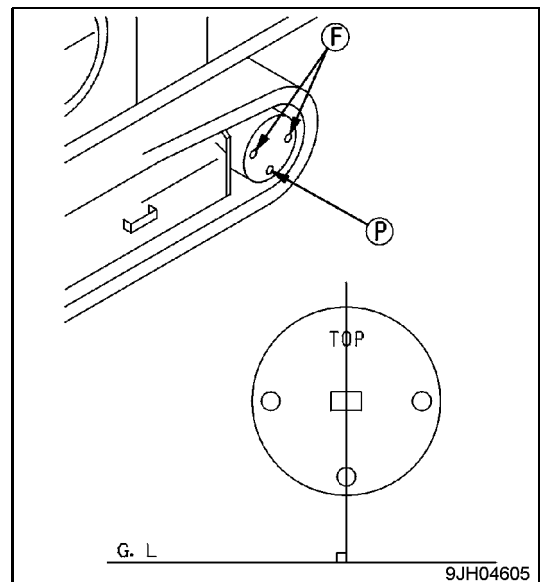

7. Run the engine at idling for a short time, then stop the engine and check again that the oil level is between the (H) and (L) marks on dipstick (G).
8. Install cover (1).

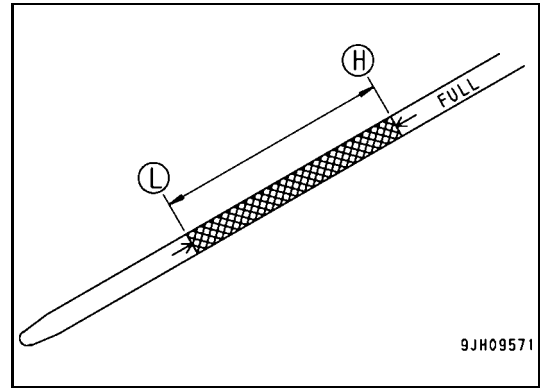

CLEAN/INSPECT RADIATOR, OIL COOLER, AFTERCOOLER AND CONDENSER FINS

⚠ WARNING

If compressed air, high-pressure water, or steam hit your body directly, or they cause dirt or dust to be blown up, there is a hazard of serious injury. Always use safety glasses, dust mask, or other protective equipment.

Remark

When using compressed air for cleaning, blow it keeping some distance to avoid damaging the fins. Damage on the fins can cause water leakage and overheating. In a dusty job site, check the fins every day, regardless of the maintenance interval.

1. Open the engine hood.
2. Loosen screw (1) and pull up net (2).
3. Clean net (2). (it is to be installed again, as instructed in the step 8.)

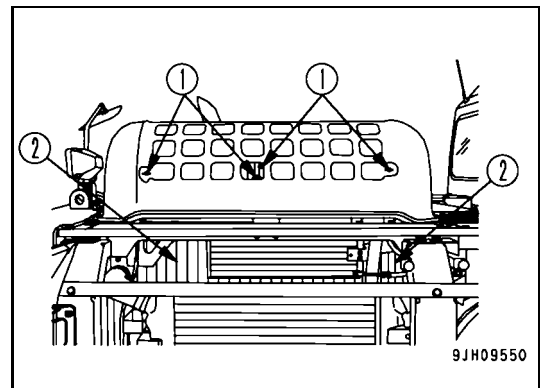

4. Remove 6 bolts (3), then move bracket (4) to the side and make a gap between radiator fins (5) and oil cooler fins (6).
5. Inspect the front and rear of radiator fins (5), oil cooler fins (6), after-cooler fins (7) and condenser fins (8) for dirt, dust, dry leaves, etc. Blow them away with compressed air, if any. Steam or water may be used instead of compressed air.

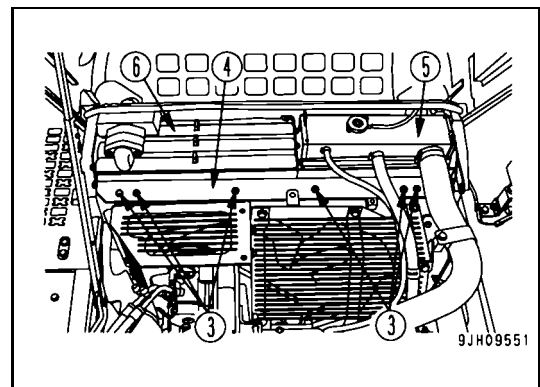

REPLACE HYDRAULIC TANK ADDITIONAL VENT ELEMENT

⚠ WARNING

The parts and oil are at high temperature immediately after the engine is stopped, and may cause burns. Wait for the temperature to go down before starting the work.

When removing the oil filler cap, turn it slowly to release the internal pressure, then remove it.

1. Remove screw (2) of vent assembly (1) at the top of the hydraulic tank, then remove cover (3).

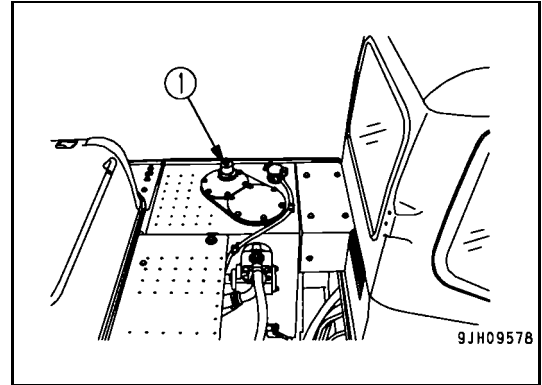

2. Replace filter element (4) with a new element.
3. Install cover (3) and screw (2).

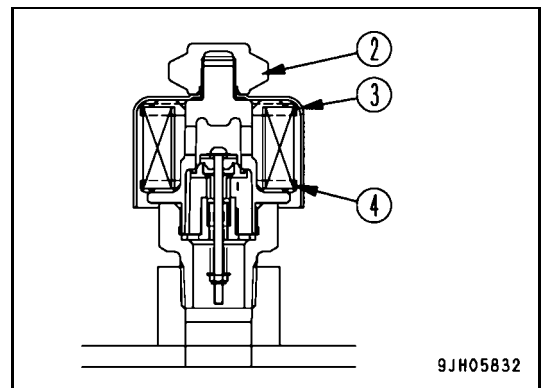

CHECK NITROGEN GAS CHARGE PRESSURE IN ACCUMULATOR (FOR BREAKER)

(If equipped)

A special tool is needed for inspecting and charging with nitrogen gas. Have your Komatsu distributor inspect and charge the accumulator.

EVERY 5000 HOURS MAINTENANCE

Maintenance for every 250, 500, and 1000 hours service should be performed at this time.

CHANGE OIL IN HYDRAULIC TANK

⚠ WARNING

The parts and oil are hot after the engine is stopped and may cause serious burns. Wait for the temperature to cool before changing the oil in the hydraulic tank.

When the oil filler cap is removed, oil may spurt out so turn the cap slowly to release the internal pressure, then remove it carefully.

- If the machine is equipped with a hydraulic breaker, the hydraulic oil will deteriorate much faster than during normal bucket operations.
 - Refill, capacity: 188 liters (49.67 US gal)
 - Prepare a flex handle (for the socket wrench).
1. Swing the upper structure so that hydraulic tank drain plug (P) and drain plug (A) at the bottom of the pump suction tube are in the middle between the left and right tracks.
 2. Retract the arm and bucket cylinders, then lower the boom and put the teeth in contact with the ground.
 3. Set the lock lever to the LOCK position and stop the engine.

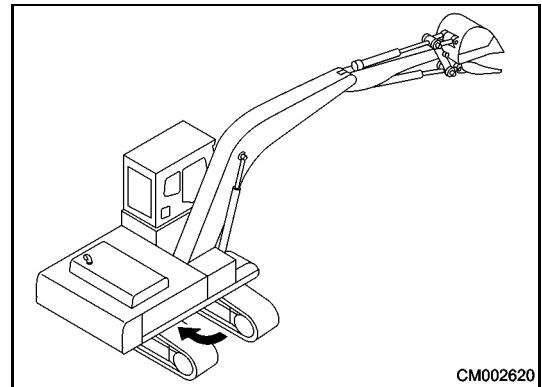

4. Remove the cap of oil filler port (F) at the top of the hydraulic tank.
 5. Remove the undercover(1) and (2).
 6. Set the oil container under the drain plug under the machine.
- Using the flex handle, remove drain plug (P), (A) and drain the oil.
- Check the O-ring installed to plug (P), (A), and if it is damaged, replace the O-ring. After draining the oil, tighten drain plug (P), (A).

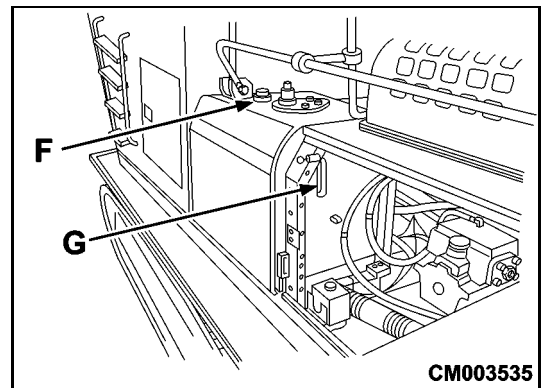

Torque of drain plug (P) and (A): 58.8 - 78.5 Nm (43.3 - 57.9 lbf/ft)

- When removing drain plug (P), (A), be careful not to get oil on yourself.
 - First, remove drain plug (P) at the bottom of the tank, then remove drain plug (A) at the suction tube. If they are removed in this order, almost the same amount of oil can be drained.
7. Add the replacement amount of oil through oil filler (F). Check to be sure the oil level is between the H and L lines on the sight gauge (G).
 8. Install the undercover (1) and (2).
 9. Bleed air from the hydraulic circuit.

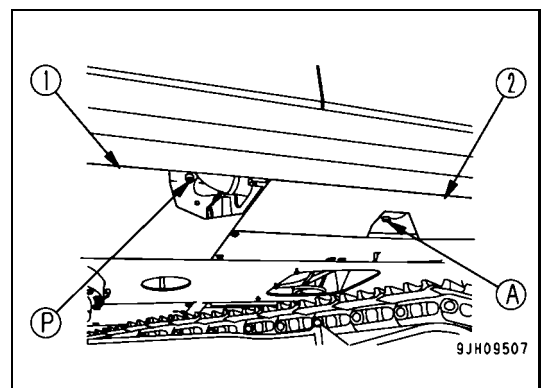

Working ranges		Unit	PC300LL-7E0 LOG LOADER
			42 ft Komatsu Forest Front
A	Max reach	mm	12767
B	Max reach at ground level		12544
C	Max depth		4546
D	Max height		14838

CLICK HERE TO **DOWNLOAD** THE COMPLETE MANUAL

- Thank you very much for reading the preview of the manual.
- You can download the complete manual from: www.heydownloads.com by clicking the link below



- Please note: If there is no response to CLICKING the link, please download this PDF first and then click on it.

CLICK HERE TO **DOWNLOAD** THE COMPLETE MANUAL