

# Operation & Maintenance Manual

## PC150-6K PC150LC-6K

### HYDRAULIC EXCAVATORS

SERIAL NUMBERS **PC150-6K - K30001** and up  
**PC150LC-6K - K30001**

This material is proprietary to Komatsu America International Company and is not to be reproduced, used, or disclosed except in accordance with written authorization from Komatsu America International Company.

It is our policy to improve our products whenever it is possible and practical to do so. We reserve the right to make changes or add improvements at any time without incurring any obligation to install such changes on products sold previously.

Due to this continuous program of research and development, periodic revisions may be made to this publication. It is recommended that customers contact their distributor for information on the latest revision.

CLICK HERE TO **DOWNLOAD** THE COMPLETE MANUAL

- Thank you very much for reading the preview of the manual.
- You can download the complete manual from: [www.heydownloads.com](http://www.heydownloads.com) by clicking the link below



- Please note: If there is no response to CLICKING the link, please download this PDF first and then click on it.

CLICK HERE TO **DOWNLOAD** THE COMPLETE MANUAL

# SAFETY



## WARNING

**Read and follow all safety precautions. Failure to do so may result in serious injury or death.**

This safety section also contains precautions for optional equipment and attachments.

**WARNING:** Failure to follow these safety precautions may lead to a serious accident.

### PRECAUTIONS WHEN TRAVELLING

- Fold in the work equipment as shown in the diagram below, and keep it at a height of 40-50 cm (16 to 20 in) from the ground level before starting to travel.
- When travelling, do not operate the work equipment control levers. If the work equipment control levers have to be operated, never operate them suddenly.
- When travelling on rough ground, travel at low speed, and avoid sudden changes in direction.
- Avoid travelling over obstacles as far as possible. If the machine has to travel over an obstacle, keep the work equipment as close to the ground as possible and travel at low speed. Never travel over obstacles which make the machine tilt strongly ( $10^\circ$  or more).

Travel posture

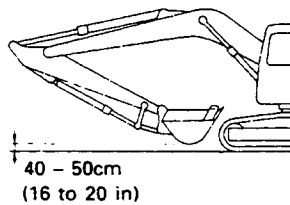

INCORRECT

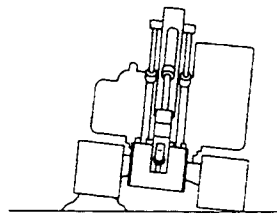

### TRAVELLING ON SLOPES

- Travelling on hills, banks or slopes that are steep could result in the machine tipping over or slipping.
- On hills, banks or slopes, carry the bucket closer to the ground, approximately 20 to 30 cm (8 to 12 in) above the ground. In case of emergency, quickly lower the bucket to the ground to help the machine stop and prevent it from tipping over.
- Do not turn on slopes or travel across slopes. Always go down to a flat place to perform these operations.  
**Method of travelling on slopes** → See 12.12 “PRECAUTIONS WHEN TRAVELLING UP OR DOWN HILLS.”
- Do not travel up and down on grass, fallen leaves, and wet steel plates. These materials may allow the machine to slip, if it is travelling sideways. Keep travel speed very low.

Downhill

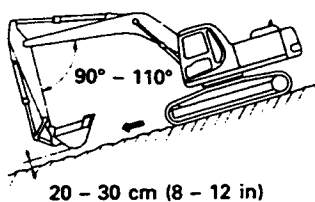

Uphill

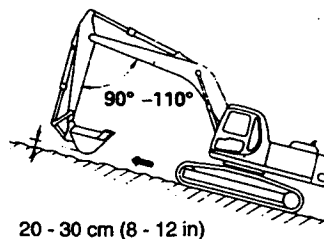

INCORRECT

CORRECT

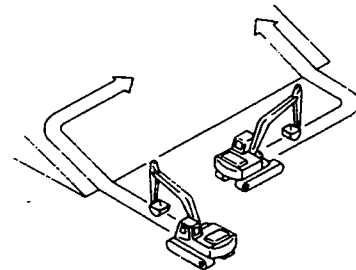

## 8. PRECAUTIONS FOR MAINTENANCE

### 8.1 BEFORE CARRYING OUT MAINTENANCE

#### WARNING TAG

- If others start the engine or operate the controls while you are performing service or lubrication, you could suffer serious injury or death.
- ALWAYS attach the WARNING TAG to the control lever in the operator's cab to alert others that you are working on the machine. Attach additional warning tags around the machine, if necessary.
- These tags are available from your Komatsu distributor. (Part no. 09963-03000)

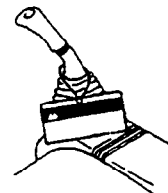
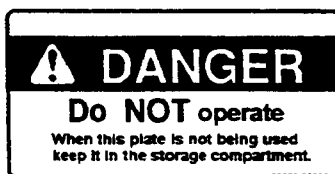

#### PROPER TOOLS

- Use only tools suited to the task. Using damaged, low quality, faulty, or makeshift tools could cause personal injury.

**Tools** → See 21.1 “INTRODUCTION OF NECESSARY TOOLS”.



#### PERIODIC REPLACEMENT OF SAFETY CRITICAL PARTS

- Replace the following fire-related components periodically:
  - Fuel system: Fuel hose, spilling hose, and fuel tube cap
  - Hydraulic system: Pump outlet hose, and front and rear pump branch hoses
- Replace these components periodically with new ones, regardless of whether or not they appear to be defective. These components deteriorate over time.
- Replace or repair any such components if any defect is found, even though they have not reached the time specified. Replacement of safety critical components  
→ See 22 “PERIODIC REPLACEMENT OF SAFETY CRITICAL PARTS”.

**⚠ WARNING:** Failure to follow these safety precautions may lead to a serious accident.

---

9. Warnings for hot water  
(14X-98-11531)

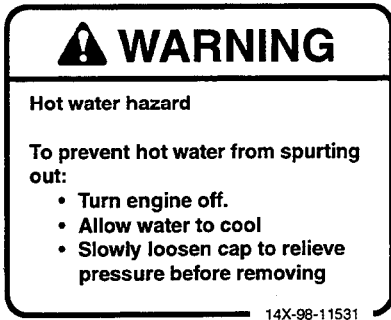

10. Warnings when opening front window  
(203-00-61280)

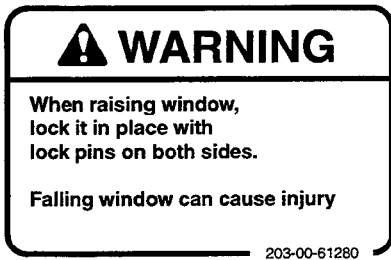

11. Explanation off emergency exit  
(20Y-00-22880)

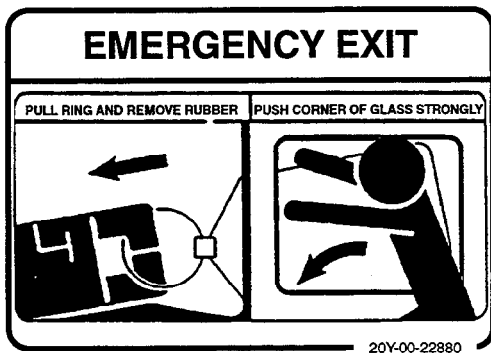

**METERS**

**3. ENGINE WATER TEMPERATURE GAUGE**

This gauge indicates the engine cooling water temperature.

If the temperature is normal during operation, the green range will light up.

If the red range lights up during operation, the overheat prevention system will be actuated.

The overheat prevention system acts as follows.

Red range ① lights up:

Output horsepower drops, and water temperature monitor ③ flashes.

When red range ② lights up:

Engine speed is lowered further to low idling, engine water temperature monitor ③ lights up, and alarm buzzer sounds at the same time.

The overheat prevention system is actuated until the temperature enters the green range.

When red range ② lights, if the engine water temperature is reduced and the fuel control dial is turned to the low idling position, the display will be cancelled.

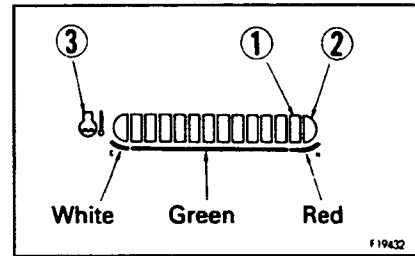

**4. FUEL GAUGE**

This gauge indicates the amount of fuel in the fuel tank. If the fuel level is normal during operation, the green range will light up.

If only the red range lights up during operation, there is less than 55 litres (14.5 US gal, 12.2 UK gal) of fuel remaining in the tank, so check and add fuel.

After the starting switch is turned ON, the correct level may not be displayed for a moment, but this does not indicate any abnormality.

When stopping the engine, turn the starting switch ON and check that the monitor lamps on items A, B, C and D and the meters light up.

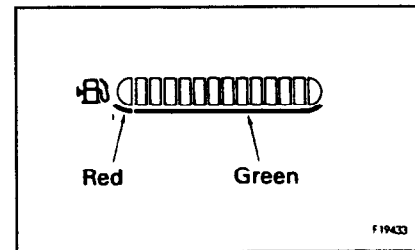

**5. DISPLAY**

This normally displays the clock time. If there is any abnormality, the type of failure is indicated when the starting switch is turned ON.

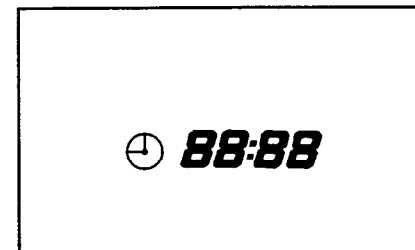

## 11. EXPLANATION OF COMPONENTS

This lever locks the work equipment, swing and attachment controls.

This lock lever is a hydraulic lock, so even if it is in the lock position, the work equipment control lever will move, but the work equipment and swing motor will not work.

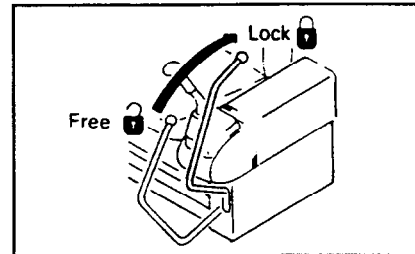

## 2. TRAVEL LEVERS (WITH PEDAL, AUTO-DECELERATION MECHANISM)

### WARNING

- Do not put your foot on the pedal unless the machine is traveling. If you leave your foot on the pedal and press it by mistake, the machine will move suddenly, and this may lead to a serious accident.
- With the track frame facing to the rear, the machine will move in the reverse direction by forward travelling and in the forward direction by reverse travelling.  
When the travel lever is used, check to see if the track frame is facing forward or backward. (If the sprocket is located to the rear, the track frame is facing forward.)

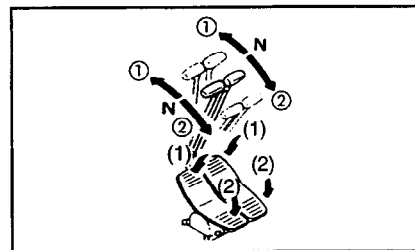

- ① FORWARD  
The lever is pushed forward  
(The pedal is angled forward)
- ② REVERSE:  
The lever is pulled back.  
(The lever is angled back)
- N (Neutral): The machine stops

( ) This indicates operation of the pedal.

### REMARK

#### Machines equipped with travel alarm (Option)

If the lever is shifted to the advance or reverse position from the neutral position, the alarm sounds to warn that the machine is starting to advance.

## 11. EXPLANATION OF COMPONENTS

### 3. Temperature control slider

This adjust out air temperature

To increase temperature of outlet air: move slides to left (red)

To decrease temperature of outlet air: move slides to right (blue)

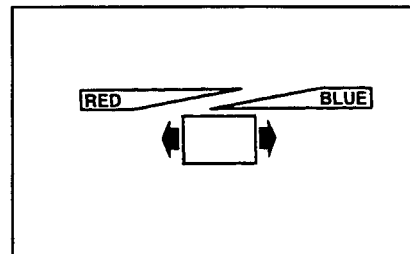

### 4. Air flow selector switch

This switch adjust air flow in three steps

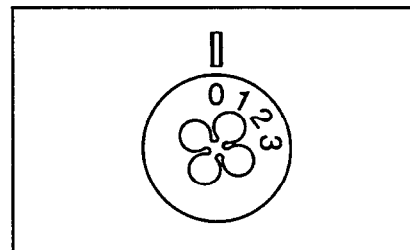

### 5. Defroster selector lever

This lever is used to remove condensation or ice from the lower part of front window.

Selector lever forward: defrost

Selector lever backward: warms operator's feet

Defroster is available when air outlet slider is in the position shown

marked:

Ⓐ DEFROSTER

Ⓑ FEET

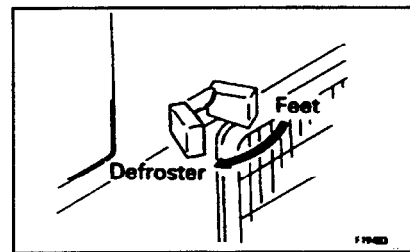

## 11.11 AIR CONDITIONER(OPTION)

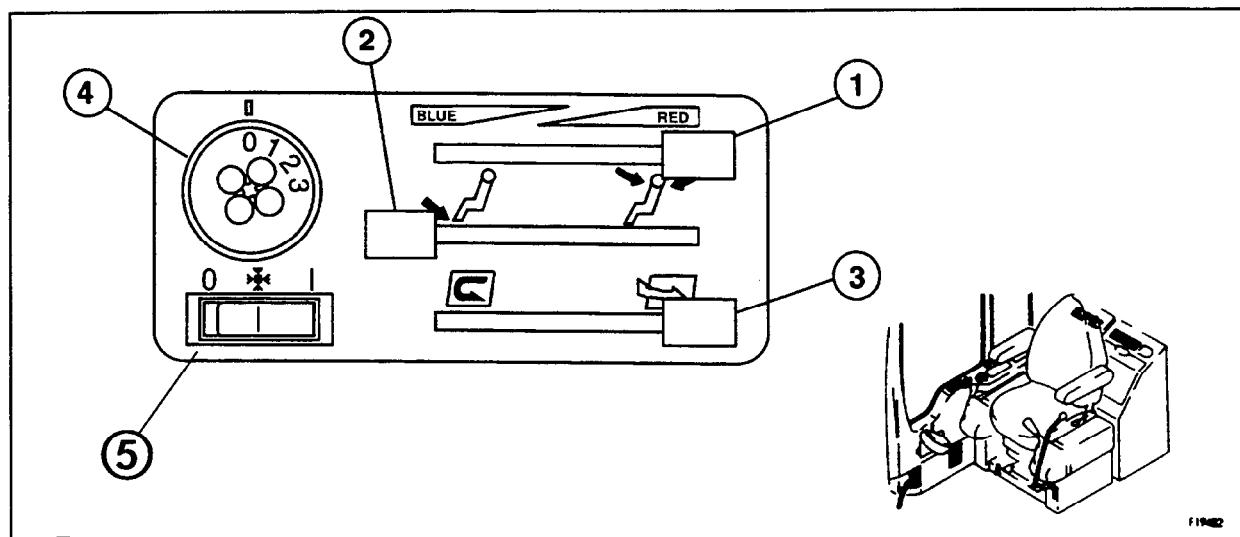

### Description

The optional air conditioner can be used to cool, heat & de-humidify operators cab.

#### 1. HEAT CONTROL SLIDER

By sliding control lever ① to the right (red) the air passing through the airconditioner unit will be warmed. In heating mode fresh ambient temperature air can be introduced to the cab when the lever ① is to the left (blue). In air conditioner mode temperature is controlled by adjusting lever ① to introduce some warm air to achieve desired temperature.

### 12.1.2 CHECK BEFORE STARTING

Always carry out the items in this section before starting the engine each day.

#### CHECK COOLANT LEVEL, ADD WATER

**⚠ WARNING**

Do not open the radiator cap unless necessary. When checking the coolant, always check the radiator reserve tank when the engine is cold.

1. Open the rear door on the left side of the machine and check that the cooling water level is between the FULL and LOW marks on radiator reserve tank ② (shown in the diagram on the right). If the water level is low, add water through the water filler of reserve tank ② to the FULL level.
2. After adding water, tighten the cap securely.
3. If the reserve tank becomes empty, first inspect for water leaks and then fill the radiator and the reserve tank with water.

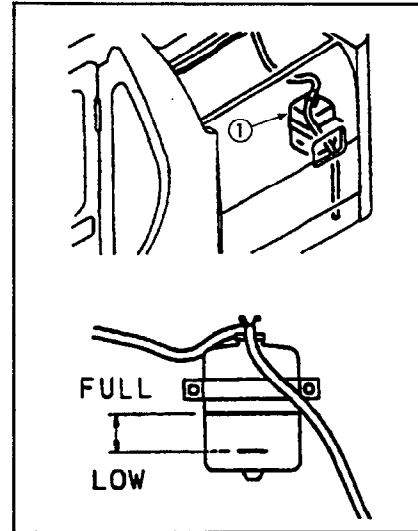

#### CHECK OIL LEVEL IN ENGINE OIL PAN, ADD OIL

1. Open the engine hood.
2. Remove dipstick ③ and wipe the oil off with a cloth.
3. Insert dipstick ③ fully in the oil filler pipe, then take it out again.
4. The oil level should be between the H and L marks on dipstick ③

If the oil level is below the L mark, add engine oil through oil filler ④. For details of the oil to use, see 20. "USE OF FUEL, COOLANT AND LUBRICANTS ACCORDING TO AMBIENT TEMPERATURE".

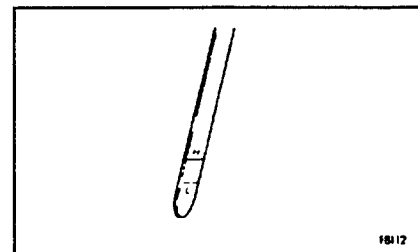
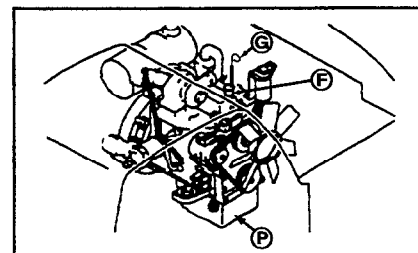

## 12. OPERATION

3. When preheating monitor ③ flashes, turn the key in starting switch ② to the START position to start the engine.

Ambient temperature	Preheating time
Above 0°C 32°F	-
32°F to 14°F / 0°C to -10°C	20 seconds
14°F to -4°F / -10°C to -20°C	30 seconds

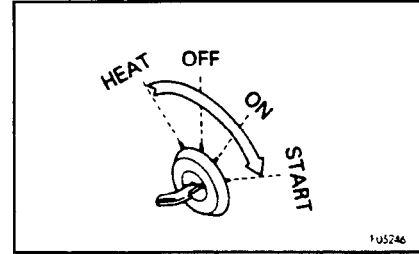

4. When the engine starts, release the key in starting switch ②. The key will return automatically to the ON position.

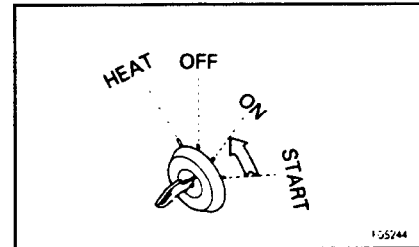

## 12.5 STEERING MACHINE

### 12.5.1 STEERING (changing direction)

**⚠ WARNING**

Before operating the travel levers, check the position of the sprocket. If the sprocket is at the front, the operation of the travel levers is reversed.

Use the travel levers to change direction.

Avoid sudden changes of direction as far as possible. In particular, when carrying out counter-rotation (spin turn), stop the machine first before turning.

Operate two travel levers ① as follows.

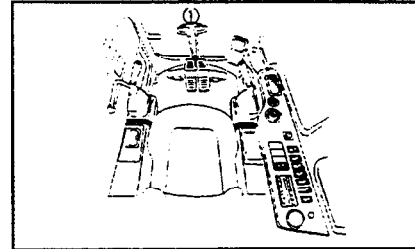

#### Changing direction of machine when stopped

When turning to the left:

Push the right travel lever forward to travel left when travelling forward; and pull it back to turn left when travelling in reverse.

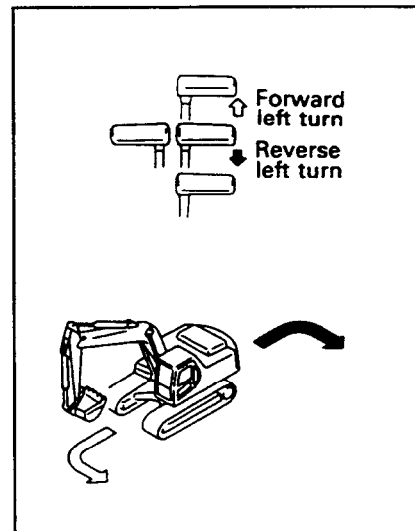

#### REMARK

When turning to the right, operate the left travel lever in the same way.

#### Steering when travelling (left and right travel levers both operated in same direction)

When turning to the left:

If the left travel lever is returned to the neutral position, the machine will turn to the left.

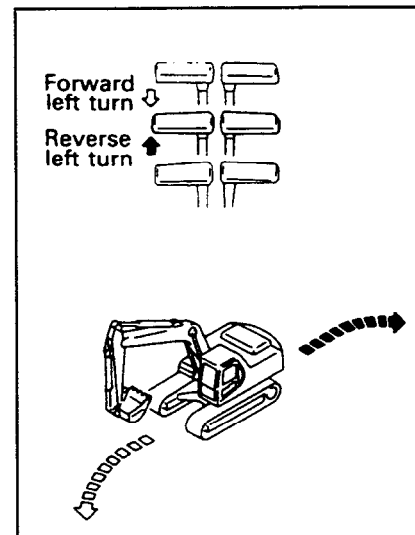

#### REMARK

When turning to the right, operate the right travel lever in the same way.

## 12.12 PRECAUTIONS WHEN TRAVELLING UP OR DOWN HILLS

### ⚠ WARNING

- When travelling, raise the bucket approx. 20 - 30 cm (8 - 12 in) from the ground. Do not travel downhill in reverse.
- When travelling over ridges or other obstacles, keep the work equipment close to the ground and travel slowly.
- It is dangerous to turn on slopes or to travel across slopes. Always go down to a flat place to perform these operations. It may be longer, but it will ensure safety.
- If the machine starts to slide or loses stability, lower the bucket immediately and brake the machine.
- Turning or operating the work equipment when working on slopes may cause the machine to lose its balance and turn over, so avoid such operations. It is particularly dangerous to swing downhill when the bucket is loaded. If such operations have to be carried out, pile soil to make platform on the slope so that the machine can be kept horizontal when operating.
- Do not travel on slopes of over 30° as there is danger that the machine may overturn.

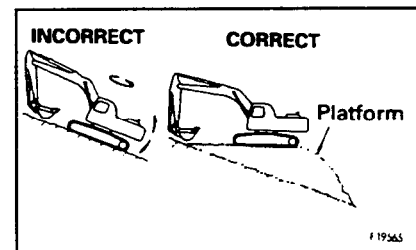
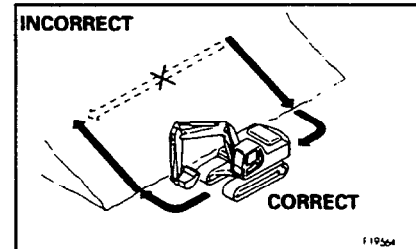

- 1) When travelling down steep hills, keep the travel speed low. When travelling down slopes of more than 15°, set the work equipment in the posture shown in the figure on the right, and lower the engine speed.

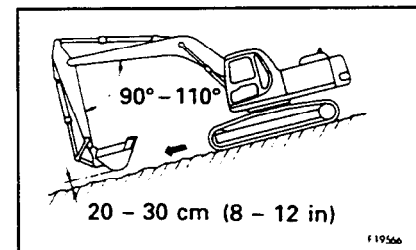

- 2) When travelling up a steep hill of more than 15°, set the work equipment in the posture shown in the diagram on the right.

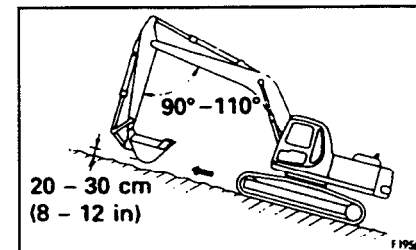

CLICK HERE TO **DOWNLOAD** THE COMPLETE MANUAL

- Thank you very much for reading the preview of the manual.
- You can download the complete manual from: [www.heydownloads.com](http://www.heydownloads.com) by clicking the link below



- Please note: If there is no response to CLICKING the link, please download this PDF first and then click on it.

CLICK HERE TO **DOWNLOAD** THE COMPLETE MANUAL

# 13. TRANSPORTATION

When transporting the machine, observe all related laws and regulations, and be careful to assure safety.

## 13.1 LOADING, UNLOADING WORK

### WARNING

- Loading or unloading the machine can be a dangerous operation, so be particularly careful.  
When loading or unloading the machine, run the engine at low idling and travel at low speed.
- Make sure the ramp has sufficient width, length and thickness to enable the machine to be safely loaded and unloaded. If the ramp sags appreciably, reinforce it with blocks, etc.
- When loading and unloading the machine, park the trailer on a flat firm roadbed. Keep a fairly long distance between the road shoulder and the machine.
- Remove the mud from the undercarriage to prevent the machine from slipping to the side on slopes.  
Be sure the ramp surface is clean and free of grease, oil, ice and loose materials.
- Never change the direction of travel when on the ramps. If it is necessary to change direction, drive off the ramps and correct the direction, then drive on to the ramps again.
- When turning the machine on the trailer, the machine's footing is unstable, so carry out the operation slowly.
- Always check that the door on the cab is locked, regardless of whether it is open or closed.  
Do not open or close the door on ramps or on a platform. This may cause a sudden change in the operating force.
- When loading or unloading the machine with the automatic warming-up operation mode, if the automatic mode is released, the speed may change suddenly. Avoid loading or unloading during automatic warming-up operation.

When loading or unloading, always use ramps or a platform and carry out the operations as follows.

1. Properly apply the brakes on the trailer and insert blocks beneath the tyres to ensure that it does not move. Then fix the ramps in line with the centers of the trailer and the machine. Be sure that the two sides are at the same level as one another.

Make the angle of the ramps a maximum of 15°.

Set the distance between the ramps to match the center of the tracks.

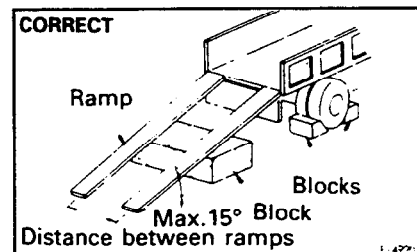

### 16.4 PRECAUTIONS ON PARTICULAR JOBSITES

1. When carrying out digging operations in water, if the work equipment mounting pin goes into the water, carry out greasing every time the operation is carried out.
2. For heavy-duty operations and deep digging, carry out greasing of the work equipment mounting pins every time before operation.

After greasing, operate the boom, arm and bucket several times, then grease again.

### 16.5 IF BATTERY IS DISCHARGED

**⚠ WARNING**

- When checking or handling the battery, stop the engine and turn the starting switch key to the OFF position before starting.
- The battery generates hydrogen gas, so there is danger of explosion. Do not bring lighted cigarettes near the battery, or do anything that will cause sparks.
- Battery electrolyte is dilute sulphuric acid, and it will attack your clothes and skin. If it gets on your clothes or on your skin, wash it immediately with large amounts of water. If it gets in your eyes, wash it out with fresh water, and consult a doctor.
- When handling battery, always wear protective goggles.
- When removing the battery, first disconnect the cable from the ground (normally, from the negative  $\ominus$  terminal). When installing, install the positive  $\oplus$  terminal first. If a tool touches the cable connecting the positive terminal and the chassis, there is danger that it will cause sparks.
- If the terminals are loose, there is danger that the defective contact may generate sparks that will cause an explosion. When installing the terminals, install them tightly.
- When removing or installing, check which is the positive terminal and negative  $\ominus$  terminal.

When removing, disconnect the cable from the ground terminal first.

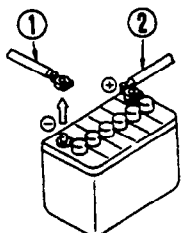

When installing, connect the cable to the positive (+) terminal first.

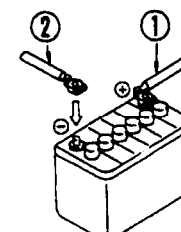

# 17. GUIDES TO MAINTENANCE

---

Do not carry out any inspection and maintenance operation that is not given in this manual.  
Perform maintenance work on hard, flat ground.

## **Check service meter:**

Check the service meter reading every day to see if the time has come for any necessary maintenance to be carried out.

## **Komatsu genuine replacement parts:**

Use Komatsu genuine parts specified in the Parts Book as replacement parts.

## **Komatsu genuine oils:**

Use Komatsu genuine oils and grease. Choose oils and grease with proper viscosity's specified for ambient temperature.

## **Always use clean washer fluid:**

Use automobile window washer fluid and be careful not to let any dirt get into it.

## **Always use clean oil and grease:**

Use clean oil and grease. Also, keep containers of the oil and grease clean. Keep foreign materials away from oil and grease.

## **Keeping the machine clean:**

Always keep the machine clean. This makes it easier to find parts causing problems. Keep in particular grease fittings, breathers and oil level gauges clean and avoid foreign matters from getting in them.

## **Be careful of hot water and oil:**

Draining hot oils and coolants and removing their filters immediately after the engine stops is hazardous. Allow the engine to cool.

If the oil has to be drained when it is cold, warm up the oil to a suitable temperature (approx. 20 - 40°C) before draining it.

## **Checking foreign materials in drained oil and on filter:**

After oil is changed or filters are replaced, check the oil and filters for metallic particles and foreign materials. If large quantities of metallic particles or foreign materials are found, consult your Komatsu distributor.

## **Fuel strainer:**

If your machine is equipped with a fuel strainer, do not remove it while fuelling.

## **Oil change:**

Check or change oils in the places where dust is scarce to keep foreign materials away from oils.

# 20. USE FUEL, COOLANT AND LUBRICANTS ACCORDING TO AMBIENT TEMPERATURE

## PROPER SELECTION OF FUEL, COOLANT AND LUBRICANTS

RESERVOIR	KIND OF FLUID	AMBIENT TEMPERATURE								CAPACITY	
		-22 -30	-4 -20	14 -10	32 0	50 10	68 20	86 30	104°F 40°C	Specified	Refill
Engine oil pan	Engine oil	SAE 30								16 ℓ 4.23 USgal 3.52 UKgal	16 ℓ 4.23 USgal 3.52 UKgal
		SAE 10W									
		SAE 10W-30									
		SAE 15W-40									
Swing machinery case	Engine oil									4 ℓ 1.06 USgal	4 ℓ 1.06 USgal
		SAE 30									
Final drive case (each)	Engine oil									4 ℓ 1.06 USgal 0.88 UK gal	4 ℓ 1.06 USgal 0.88 UK gal
Hydraulic system	Engine oil	SAE 10W								190 ℓ 50.26 USgal 44.8 UKgal	135 ℓ 35.7 USgal 41.8 UKgal
		SAE 10W-30									
		SAE 15W-40									
Fuel tank	Dieselfuel	*				ASTM D975 No.2				250 ℓ 66.1 USgal 55.0 UKgal	-
All lubrication fittings	Grease	No. 2 Multi-Purpose lithium grease with 3% molybdenum disulfide									
Cooling system	Coolant	See Spectrum XXX, Komatsu Genuine Lubricants								20 ℓ 5.29 USgal 4.40 UKgal	-

\* ASTM D975 No. 1

## 23. MAINTENANCE SCHEDULE CHART

SERVICE ITEM	PAGE
<b>(EVERY 500 HOURS SERVICE)</b>	
Replace hydraulic tank breather element	3-64
<b>EVERY 1000 HOURS SERVICE</b>	
Change oil in swing machinery case	3-65
Check oil level in damper case, add oil	3-66
Check all tightening parts of turbocharger	3-66
Check play of turbocharger rotor	3-66
Check and adjust valve clearance (1 <sup>st</sup> 1000 hour only)	3-67
Check fan belt tensioner bearing, belt and fan hub	3-70
Check fan belt tension	3-71
<b>EVERY 2000 HOURS SERVICE</b>	
Check oil level in final drive case, add oil	3-72
Change oil in hydraulic tank, clean strainer	3-73
Clean, check turbocharger	3-78
Check alternator, starting motor	3-78
Check vibration damper	3-78
Change antifreeze	3-78
<b>EVERY 4000 HOURS SERVICE</b>	
Check water pump	3-79

### 23.2 MAINTENANCE WHEN USING HYDRAULIC BREAKER

For machines equipped with a hydraulic breaker, the hydraulic oil deteriorates faster than for normal bucket digging operations, so set the maintenance intervals as follows.

- Replacing hydraulic filter element  
On new machines, replace the element after the first 100 to 150 hours, then carry out further replacement of the element according to the table on the right.
- Changing oil in hydraulic tank  
Change the oil according to the table on the right.
- Replacing additional filter element for breaker  
Use a guideline of 250 hours for use of the breaker operating ratio for the breaker: 50% or more) and replace the element according to the table on the right.

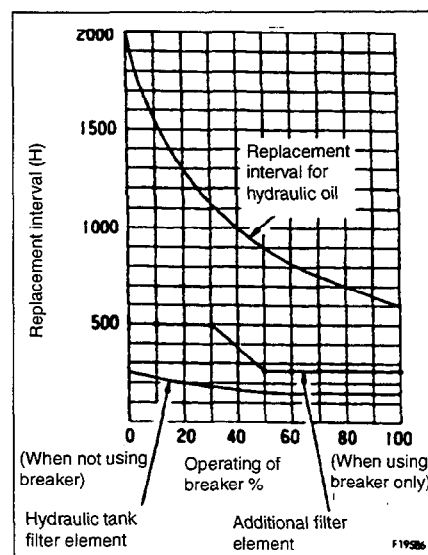

### 24.1.10 THERMOSTATS

#### REMOVAL

1. Drain the cooling system. Refer to "DRAINING THE SYSTEM" in this section.
2. Remove the components and housing to access the thermostats a.
3. Remove the thermostats and clean all gasket material from either mating surfaces.

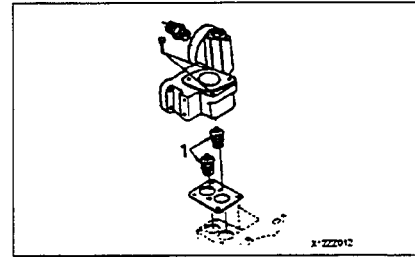

#### INSTALLATION

1. Install two new thermostats with new gasket.
2. Re-install thermostat housing and all component parts.
3. Fill the cooling system. Refer to "COOLING THE SYSTEM" in this section.

### 24.1.11 FAN

#### ⚠ WARNING

**Personal injury can result from a fan blade failure. Never pull or pry on the fan. This can damage the fan blade(s) and cause fan failure.**

Check the fan for cracks, loose rivets (for metal fans) and bent or loose blades. Make sure it is securely mounted. Tighten the capscrews if loose. Replace damaged fans.

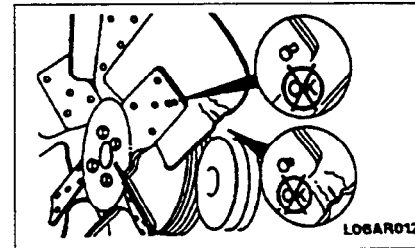

### 24.1.12 CHECK AND TIGHTEN TRACK SHOE BOLTS

If the machine is used with track shoe bolts ① loose, they will break, so tighten any loose bolts immediately.

#### Method for tightening

1. Tighten first to a tightening torque of  $390 \pm 40$  Nm ( $40 \pm 4$  kgm,  $290 \pm 30$  lb ft), then check that the nut and shoe are in close contact with the link mating surface.
2. After checking, tighten a further  $120^\circ \pm 10^\circ$ .

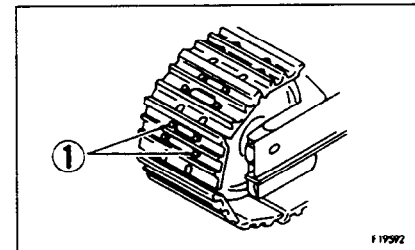

#### Order for tightening

Tighten the bolts in the order shown in the diagram. After tightening, check that the nut and shoe are in close contact with the link mating surface.

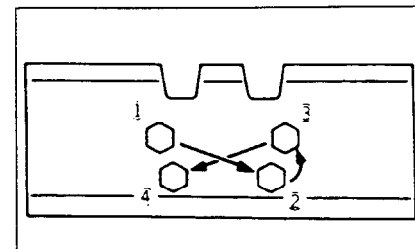

### 24.1.21 CHECK WINDOW WASHER FLUID LEVEL, ADD FLUID

If air is ejected with the window washer fluid, check the fluid level in window washer tank ①. If showing under the level, fill with automobile window washer fluid.

When adding fluid, be careful not to let dirt or dust get in.

- Mixture ratio of pure washer fluid and water

Since the ratio should be varied depending on atmospheric temperature, replenish washer fluid at the following mixture ratio, taking temperature into account.

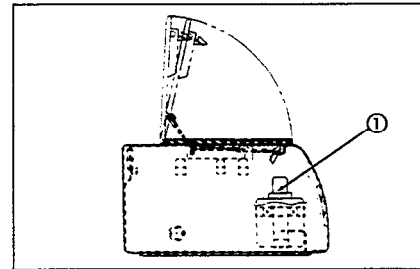

Operation area and season	Mixture ratio	Freezing temperature
Normal	Pure washer fluid 1/3: water 2/3	- 10° C(14°F)
Winter in cold region	Pure washer fluid 1/2: water 1/2	- 20°C (- 4°F)
Winter in extremely cold region	Pure washer fluid	- 30°C (- 22°F)

Pure washer fluid comes in two types: for -10°C(14°F) (for general use) and for -30°C (-22°F) (cold regions).

Use pure washer fluid according to operation area and season.

## 24. SERVICE PROCEDURE

7. Boom foot pin (2 points)

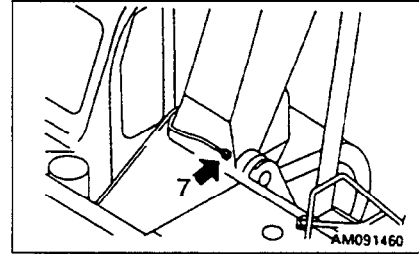

8. Arm-Link coupling pin (1 point)

9. Arm-Bucket coupling pin (1 point)

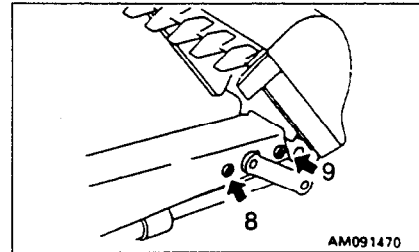

10. Link coupling pin (2 points)

11. Bucket cylinder rod end (1 point)

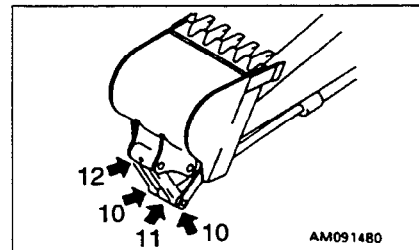

12. Bucket-Link coupling pin (1 points)



### 24.3.2 CHECK OIL LEVEL IN SWING MACHINERY CASE, ADD OIL

#### WARNING

The oil is at high temperature immediately after the machine has been operated. Wait for the oil to cool down before carrying out this check.

1. Remove dipstick  and wipe the oil from the dipstick with a cloth.
2. Insert dipstick  fully in the guide.
3. When dipstick  is pulled out, if the oil level is between the H and L marks of the gauge, oil level is correct.

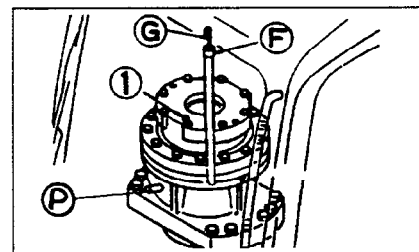

## Fuel System

### Bleeding

Controlled venting is provided at the injection pump through the fuel drain manifold. Small amounts of air introduced by changing the fuel filters or fuel injection pump supply line will be vented automatically, if the fuel filter is changed in accordance with the instructions. No manual bleeding of fuel lines is required.

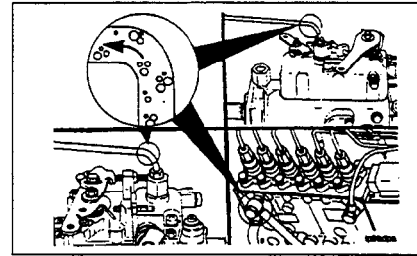

**NOTE:** Manual bleeding is required if:

- The fuel filter is not filled prior to installation.
- Fuel injection pump is replaced.
- High pressure fuel line connections are loosened or fuel lines replaced.
- Initial engine start up or start up after an extended period of no engine operation.
- Vehicle fuel tank has been run until empty.

## Low Pressure Lines and Fuel Filter(s)

### Venting

1. Open the bleed screw
2. Operate the plunger on the lift pump until the fuel flowing from the fitting is free of air.

Tighten the bleed screw.

**Torque Value:** 9 N•m [80 in-lb]

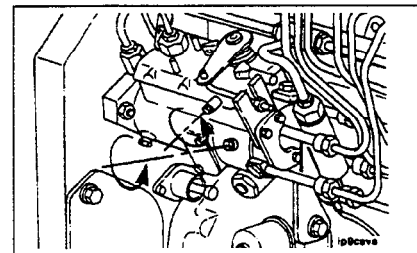
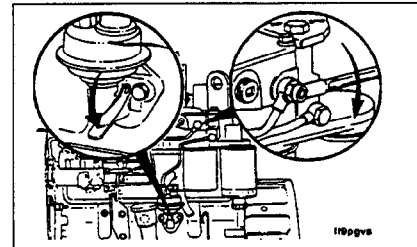
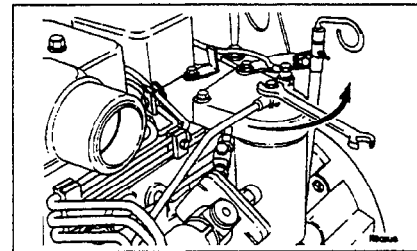

## 24.7 EVERY 2000 HOURS SERVICE

Maintenance for every 50, 100, 250, 500 and 1000 hours should be carried out at the same time.

### 24.7.1 CHANGE OIL IN FINAL DRIVE CASE

**⚠ WARNING**

- The oil is at high temperature immediately after the machine has been operated. Wait for the oil to cool down before carrying out maintenance.
- If there is still pressure remaining inside the case, the oil or plug may fly out.  
Loosen the plug slowly to release the pressure.

Prepare the following.

- Container to catch drained oil: Min. 4 ℓ capacity
- Refill capacity: 4 ℓ (1.05 US gal, 0.9 UK gal)
- Handle

1. Set the TOP mark at the top, with the TOP mark and plug ② perpendicular to the ground surface.
2. Set a container under plug ② to catch the oil.
3. Remove plug ② and ③ with the handle and drain the oil.

**REMARK**

Check the O-rings in the plugs for damage. If necessary, replace with new ones.

4. Screw in plug ②.
5. Add engine oil through the hole of plug ③.

For details of the oil to use, see 20. "USE OF FUEL, COOLANT AND LUBRICANTS ACCORDING TO AMBIENT TEMPERATURE".

6. When the oil overflows from the hole of plug ③, install plug ③.  
Tightening torque of plugs ② and ③:  $70 \pm 10\text{Nm}$  ( $7 \pm 1 \text{kgm}$ ,  $50 \pm 7 \text{lbft}$ ).

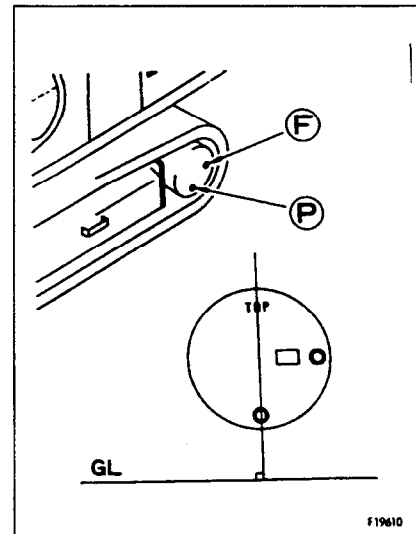

PC150-6k

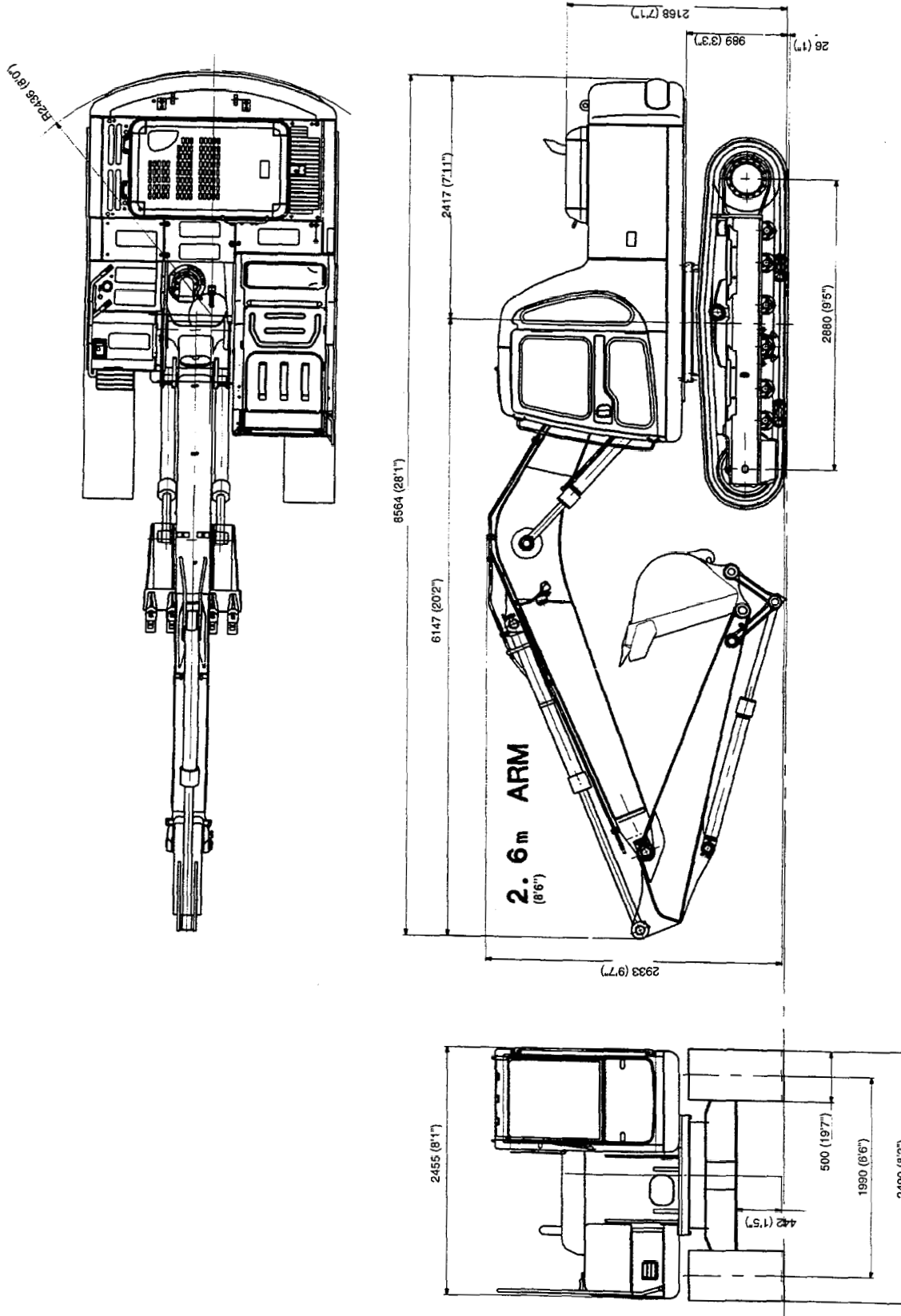

## 28. USING SEAT BELT

### 28.1 SEAT BELT

**WARNING**

- Before fastening the seat belt, inspect the securing brackets and belt for abnormal conditions.  
Replace any worn or damaged seat belt or the securing brackets.
- Adjust and fasten the seat belt before operating the machine.
- Always use seat belt when operating the machine.
- Do not use seat belt with either half of the belt kinked.

#### 28.1.1 FASTEN THE BELT AND REMOVE IT

1. Adjust the seat so that the operator still feels that there is sufficient knee room when fully depressing the pedal while seated, with operator's back against the backrest.
2. For suspension-type seat, adjust tether belt ①, after adjusting the seat position.
3. After adjusting the seat position, sit in the seat. Grip buckle ② and tongue ③ in each hand and inset tongue ③ into buckle ②. Confirm by pulling the belt that the tongue is securely locked to the buckle.
4. When removing the belt, raise the tip of buckle ② lever to release it.

Fasten belt along your body without kinking it. Adjust the lengths of the belt on both the buckle and the tongue sides so that the buckle is centered at the mid-point of your body front.

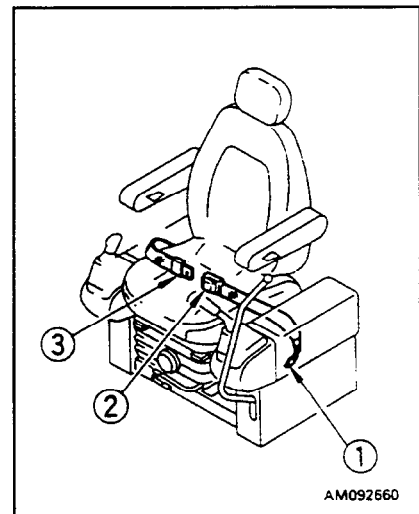

# 30. INTRODUCTION OF ATTACHMENTS

## 30.1 SPECIFICATION, USE

- PC150/PC150LC-6k

Name	Specifications, use
Narrow bucket	Capacity 0.57 m <sup>3</sup> (0.75 yd <sup>3</sup> )
	Outside width 900 mm (35.4")
Narrow bucket	Capacity 0.64 m <sup>3</sup> (0.83 yd <sup>3</sup> )
	Outside width 960 mm (37.8")
Light duty bucket	Capacity 0.80 m <sup>3</sup> (1.05 yd <sup>3</sup> )
	Outside width 1,050 mm (41.4")
Light duty bucket	Capacity 1.00 m <sup>3</sup> (1.31 yd <sup>3</sup> )
	Outside width 1,350 mm (53.1")
Shape finishing bucket	Capacity 0.35 m <sup>3</sup> (0.46 yd <sup>3</sup> )
	Compacting width 2,000 mm (6.7")
	Compacting area 2.4 m <sup>2</sup>
Trapezoidal bucket	Capacity 0.50 m <sup>3</sup> (0.65 yd <sup>3</sup> )
	Outside width
Ripper bucket	Capacity 0.56 m <sup>3</sup> (0.73 yd <sup>3</sup> )
	Outside width 990 mm (39")
One tooth ripper	Shank width 118 mm (4.65")
	Crushing depth 1,130 mm (44.5")
Three teeth ripper	Shank width 118 mm (4.65")
	Crushing depth 860 mm (33.9")
Track shoes	Triple grouser shoe width 500 mm (19.7")
	Triple grouser shoe width 600 mm (23.6")
	Triple grouser shoe width 700 mm (27.6")
	Triple grouser shoe width 800 mm (31.5")
Short arm	Arm length 1,850 mm (6'1")
	Max. digging depth 5,240 mm (17'1")
Short arm	Arm length 2,250 mm (7'1")
	Max. digging depth 5,645 mm (18'1")
Medium arm	Arm length 2,600 mm (8'1")
	Max. digging depth 6,000 mm (19'1")
Long arm	Arm length 2,900 mm (9'1")
	Max. digging depth 6,290 mm (20'1")
Head guard	In place where there is danger of falling rocks, always install the head guard to protect the operator.

CLICK HERE TO **DOWNLOAD** THE COMPLETE MANUAL

- Thank you very much for reading the preview of the manual.
- You can download the complete manual from: [www.heydownloads.com](http://www.heydownloads.com) by clicking the link below



- Please note: If there is no response to CLICKING the link, please download this PDF first and then click on it.

CLICK HERE TO **DOWNLOAD** THE COMPLETE MANUAL