

DX225LCA

Operation and Maintenance Manual

K1049155E

Serial Number 5167 and Up

July 2008

DOOSAN reserves the right to improve our products in a continuing process to provide the best possible product to the market place. These improvements can be implemented at any time with no obligation to change materials on previously sold products. It is recommended that consumers periodically contact their distributors for recent documentation on purchased equipment.

This documentation may include attachments and optional equipment that is not available in your machine's package. Please call your distributor for additional items that you may require.

Illustrations used throughout this manual are used only as a representation of the actual piece of equipment, and may vary from the actual item.

CLICK HERE TO **DOWNLOAD** THE COMPLETE MANUAL

- Thank you very much for reading the preview of the manual.
- You can download the complete manual from: www.heydownloads.com by clicking the link below



- Please note: If there is no response to CLICKING the link, please download this PDF first and then click on it.

CLICK HERE TO **DOWNLOAD** THE COMPLETE MANUAL

1. Warnings for Operation, Inspection and Maintenance (190-00688, 190-00092)

<p style="text-align: center;">⚠ WARNING</p> <ul style="list-style-type: none"> • AVOID DEATH OR SERIOUS INJURY. - READ AND UNDERSTAND OPERATION MANUAL AND SAFETY LABELS prior to operating this machine. • Never get in under the machine while it is being jacked up with boom and arm. • Sound the horn to alert the people nearby before operating, and make sure that all persons are clear of area. • Controls may be changed for attachments or operator preference. Try control pattern before operating. <p style="text-align: right; font-size: small;">190-00688</p>	<div style="border: 1px solid black; padding: 5px; text-align: center;"> </div> <p style="text-align: right; font-size: small;">190-00092</p>
---	---

ARO1080L

2. Warnings for High Voltage (190-00689, 190-00096)

	<p style="text-align: center;">⚠ DANGER</p> <p>SERIOUS INJURY OR DEATH BY ELECTROUTION can occur if machine or attachments are not a safe distance from electrical power lines.</p> <table border="1" style="width: 100%; border-collapse: collapse; font-size: small;"> <thead> <tr> <th style="text-align: left;">Line voltage</th> <th style="text-align: left;">Safe Distance</th> </tr> </thead> <tbody> <tr> <td style="text-align: center;">6.6 kv</td> <td style="text-align: left;">At least 3m(10ft)</td> </tr> <tr> <td style="text-align: center;">66.6 kv</td> <td style="text-align: left;">At least 5m(16ft)</td> </tr> <tr> <td style="text-align: center;">275.0 kv</td> <td style="text-align: left;">At least 10m(33ft)</td> </tr> </tbody> </table> <p style="text-align: right; font-size: x-small;">190-00689</p>	Line voltage	Safe Distance	6.6 kv	At least 3m(10ft)	66.6 kv	At least 5m(16ft)	275.0 kv	At least 10m(33ft)	<div style="border: 1px solid black; padding: 5px; text-align: center;"> </div> <p style="text-align: right; font-size: small;">190-00096</p>
Line voltage	Safe Distance									
6.6 kv	At least 3m(10ft)									
66.6 kv	At least 5m(16ft)									
275.0 kv	At least 10m(33ft)									

ARO1090L

Inside Operator's Compartment

When entering the operator's compartment, always remove all mud and oil from the soles of your shoes. If you operate the travel pedal with mud or oil stuck to your shoes, your foot may slip and this may cause a serious accident.

After using the ashtray, make sure that any matches or cigarettes are properly extinguished, and be sure to close the ashtray. If the ashtray is left open, there is danger of fire.

Do not stick suction pads to the window glass. Suction pads act as a lens and may cause fire.

Do not leave lighters laying around the operator's compartment. If the temperature inside the operator's compartment becomes high, there is danger that the lighter may explode.

Do not use cellular telephones inside the operator's compartment when driving or operating the machine. There is danger that this may lead to an unexpected accident.

Never bring any dangerous objects such as flammable or explosive items into the operator's cabin.

To ensure safety, do not use the radio or music headphones when operating the machine. There is danger that this may lead to a serious accident.

When operating the machine, do not put your hands or head out of the window.

When standing up from the operator's seat, always place safety lock lever securely in the "LOCK" position. If you accidentally touch the work equipment levers when they are not locked, the machine may suddenly move and cause serious injury or damage.

When leaving the machine, lower the work equipment completely to the ground, set safety lock lever to the "LOCK" position and shut down engine. Use the key to lock all the equipment. Always remove the key and take it with you.

Clothing and Personal Protective Items

Contain long hair, and avoid loose clothing and jewelry. They can catch on controls or in protruding parts and cause serious injury or death.

Do not wear oily clothes. They are highly flammable.

Full eye protection, a hard hat, safety shoes and gloves may be required at the work site.

While working on the machine, never use inadequate tools. They could break or slip, causing injury, or they may not adequately perform intended functions.

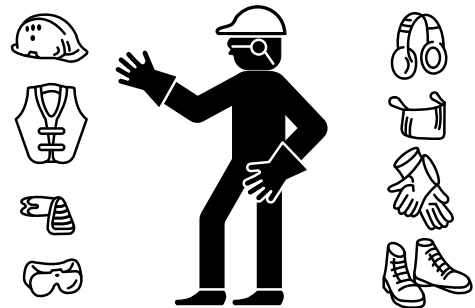

Figure 2

HAOA020L

MACHINE OPERATION

When Swinging or Changing Direction of Travel

Before operating the machine or the work equipment, always observe the following precautions to prevent serious injury or death.

- Start and operate the machine only while seated.
- When changing the direction of travel from forward to reverse or from reverse to forward, reduce speed early and stop the machine before changing the direction of travel.
- Sound the horn to warn people in the area.
- Check that there is no one in the area around the machine. There are blind spots behind the machine, so if necessary, swing the upper structure to check that there is no one behind the machine before traveling in reverse.
- When operating in areas that may be hazardous or have poor visibility, designate a person to direct work site traffic.
- Ensure that no unauthorized person can come within the turning radius or direction of travel.

Be sure to observe the above precautions even if a travel alarm or mirrors are installed.

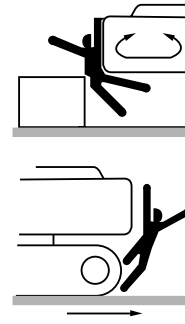

Figure 17

HAOA190L

Welding Repairs

When carrying out welding repairs, carry out the welding in a properly equipped place. The welding should be performed by a qualified worker. During welding operations, there is the danger of, generation of gas, fire, or electric shock, so never let an unqualified worker do welding.

The qualified welder must do the following;

- To prevent explosion of the battery, disconnect the battery terminals and remove batteries.
- To prevent generation of gas, remove the paint from the location of the weld.
- If hydraulic equipment, piping or places close to them are heated, a flammable gas or mist will be generated and there is danger of it catching fire. To avoid this, never subject these places to heat.
- Do not weld on pipes or on tubes that contain flammable fluids. Do not flame cut on pipes or on tubes that contain flammable fluids. Before you weld on pipes or on tubes or before you flame cut on pipes or on tubes, clean the pipes or tubes thoroughly with a nonflammable solvent.
- If heat is applied directly to rubber hoses or piping under pressure, they may suddenly break so cover them with a fireproof covering.
- Wear protective clothing.
- Make sure there is good ventilation.
- Remove all flammable objects and provide a fire extinguisher.

Warning for Counterweight and Front Attachment Removal



DANGER!

DOOSAN warns any user, that the removal of the counterweight from the machine, front attachment or any other part, may affect the stability of the machine. This could cause unexpected movement, resulting in death or serious injuries. *DOOSAN* is not liable for any misuse.

Never remove the counterweight or front attachment unless the upper structure is in-line with the lower structure.

Never rotate the upper structure once the counterweight or front attachment has been removed.

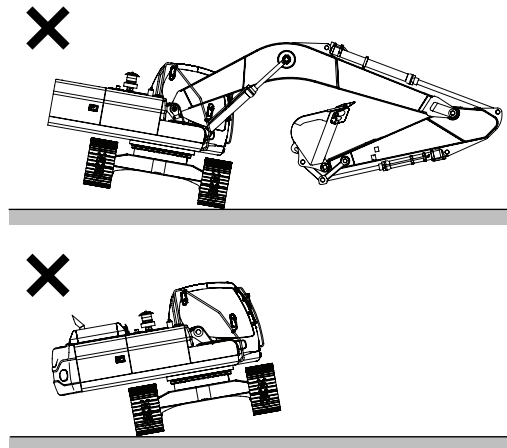

Figure 36

FG000371

Avoid traveling with a suspended load. Before swinging (or if required, traveling), bring the load into an arm position (radius and height) that has a safer weight capacity rating and adequate movement clearance. The operator and all work site personnel should be thoroughly familiar with safety instructions and procedures within this Operation and Maintenance Manual.

The following weight loads are in compliance with SAE (J1097) and ISO applicable, recommended standards for hydraulic excavators performing lifting operation on a firm supporting surface. An asterisk (*) next to the lift rating indicates rated load does not exceed 87% of hydraulic capacity. All other ratings have been determined not to exceed 75% of tipping capacity.

Do not attempt to lift or hold any load that exceeds rated load capacity at the specified distances (from the machine's rotation center line and height - see "lift radius" and "lift height" in the reference drawing, Figure 47).

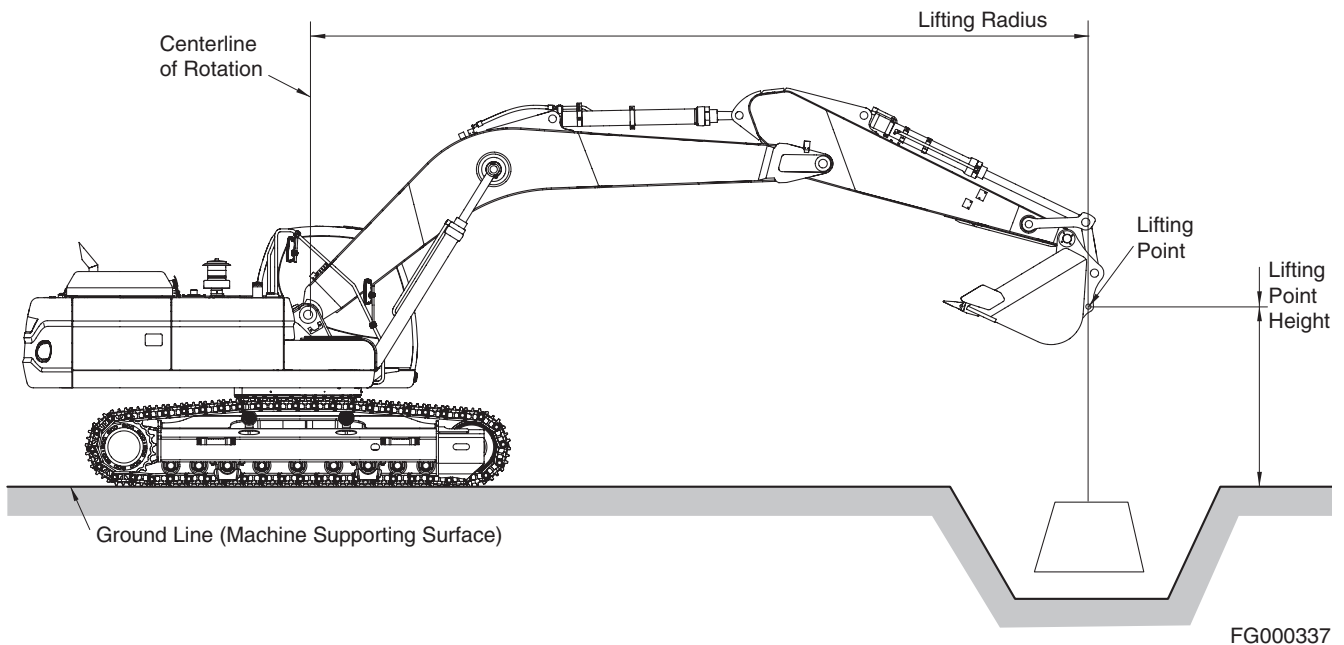

Figure 47

The weight of slings and any auxiliary lifting device (and/or the weight difference of any attachment heavier than standard configuration) must be deducted from the rated lift capacity to determine allowable net lifting load. The lift point should be on the back of the bucket, as shown in Figure 47.

IMPORTANT

Select the Digging Mode switch on the Instrument Panel before using the excavator for lifting work. Engine and hydraulic oil should both be fully warmed up to operating temperature before starting a lift.

Reference Number	Description
1	Starter Switch
2	Engine Speed Control Dial
3	Quick Clamp Switch (Optional)
4	Auxiliary Mode Switch
5	Engine Emergency Stop Cable
6	Audio Control Panel
7	Travel Speed Selector Switch
8	Light Switch
9	Breaker / Booster / Shear Selector Switch
10	Cabin Work Light Switch (Optional)
11	Warning Light Switch (Optional)
12	Lower Wiper Switch (Optional)
13	Heater and Air Conditional Control Panel

Reference Number	Description
14	Wiper Control Panel
15	Cigarette Lighter
16	Power Socket For 12v
17	Travel / Swing Alarm Switch (Optional)
18	Seat Warmer Switch (Optional)
19	Horn Button
20	Rotating Buttons
21	Booster Button
22	Shear Buttons
23	Instrument Panel
24	Safety Lever
25	Photo Sensor

20. Rotating Buttons

For a machine equipped with an attachment that rotates, press the upper two buttons on the top of the left-hand work lever (joystick) to rotate the attachment clockwise or counterclockwise. Left button is for counterclockwise and the right one is for clockwise.



WARNING!

Before using any attachment in a work application, be sure to check its functional control. Make sure that the desired movement or action is being activated by the control. e.g. opening/closing, CW/CCW, crowd/dump, etc.

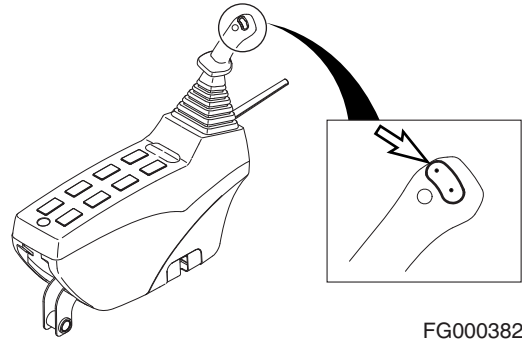

Figure 29

FG000382

21. Booster Button (Right-hand Work Lever)

Press the lower button on the top of the right-hand work lever (joystick) to boost the hydraulic pressure. Refer to the “Boost Mode” on page 3-23.

NOTE: This button works with the breaker/boost/shear selector switch. See “9. Breaker / Boost / Shear Selector Switch” on page 2-12.

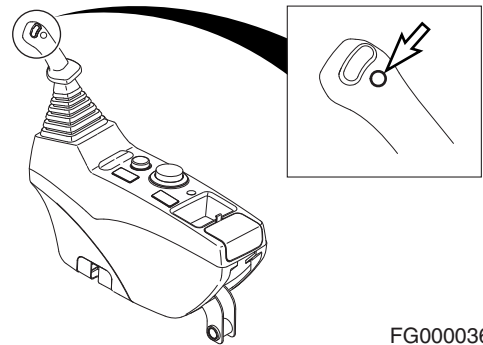

Figure 30

FG000036

22. Shear Buttons

For a machine equipped with shear, press the two upper buttons on the top of the right-hand work lever (joystick) to open or close the shear. Left button is for closing (crowd), right button is for opening (Dump).

NOTE: These buttons work with the breaker/boost/shear selector switch. See “9. Breaker / Boost / Shear Selector Switch” on page 2-12.



WARNING!

Before using any attachment in a work application, be sure to check its functional control. Make sure that the desired movement or action is being activated by the control. e.g. opening/closing, CW/CCW, crowd/dump, etc.

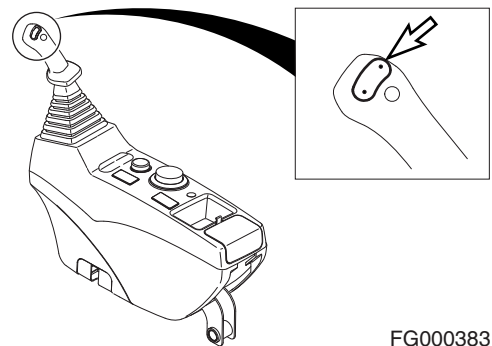

Figure 31

FG000383

Front Hydraulic Pump Pressure

The front pump pressure is numerically displayed.

NOTE: *This pump is closest to engine flywheel housing or is the upper one of hydraulic pump.*

It displays the reading in BARs.

FRONT PUMP 320 BAR

FG000051

Figure 53

Rear Hydraulic Pump Pressure

The rear pump pressure is numerically displayed.

NOTE: *This pump is the farthest from engine flywheel housing or is the lower one of hydraulic pump.*

It displays the reading in BARs.

REAR PUMP 313 BAR

FG000052

Figure 54

Abnormal State Warning Symbols

1. Hydraulic Oil Overheating Warning
2. Pilot Filter Clogged Warning
3. Fuel Shortage Warning
4. Return Filter Clogged Warning
5. Air Cleaner Clogged Warning
6. Overload Warning (Optional)

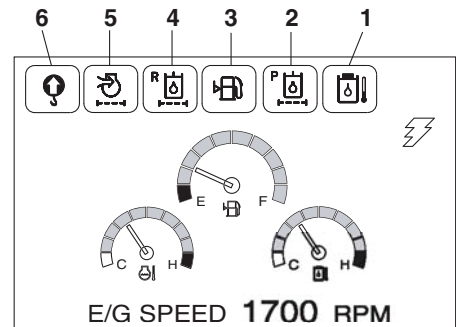

FG001088

Figure 55

Menu Display Order and Icon Explanation

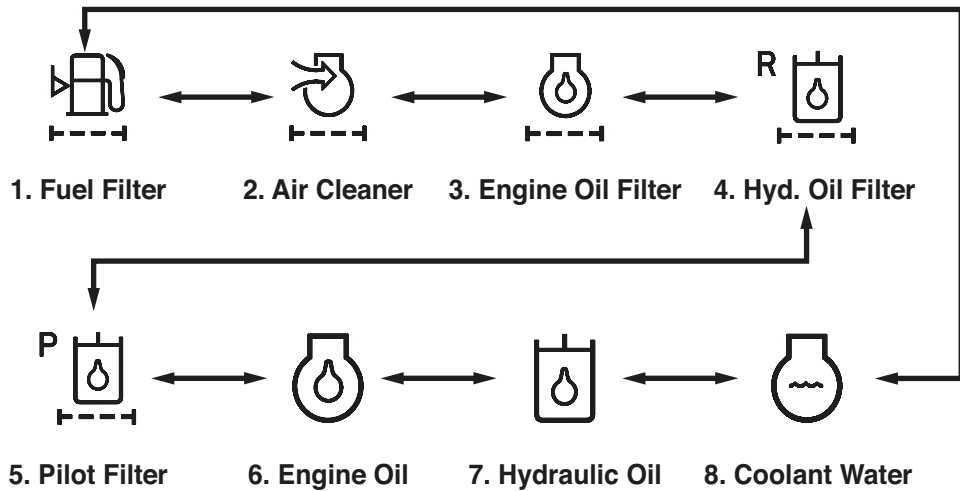

FG001358

Figure 82

Filter / Oils Operating Hour Reset

After changing a filter or oil, reset the operating hour to zero (Hrs: 0000). The next replacement period can then be easily checked. The operating hours are only accumulated while the engine is running.

On the filter / oil information screen, press the "SELECT" (←) button and then the reset screen will be displayed.

On the reset screen, the operating hour can be changed to zero hour (Hrs: 0000) by pressing the "SELECT" (←).

If the "SELECT" (←) button is pressed, the reset will be completed. and the screen will be returned to the previous menu.

If the "ESC" (☰) button is pressed, the screen will be returned to the previous menu without being reset.

NOTE: *If more than twenty seconds are spent in the menu, without changing the screen, it will return to the normal display screen.*

The screen is returned to the main menu by pressing the "ESC" (☰) button.

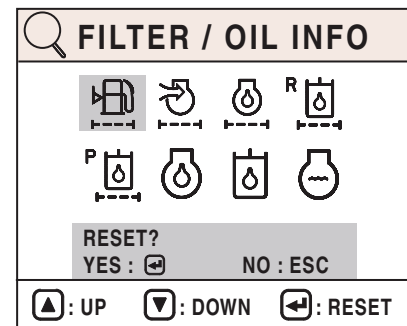

HAAE1960

Figure 83

2. Off Button

This button is used to stop the fan and air conditioner.

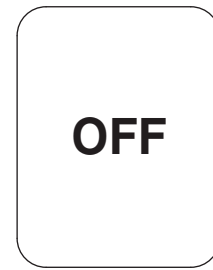

Figure 104

FG000089

3. Temperature Control Button

These buttons are used to control the cabin temperature.

Temperature is adjustable from 17°C (62°F) to 32°C (90°F) by 0.5°C (1°F) increments.

Temperature setting is displayed on the LCD.

When the system is turned "ON," the previously set temperature is used as a starting point.

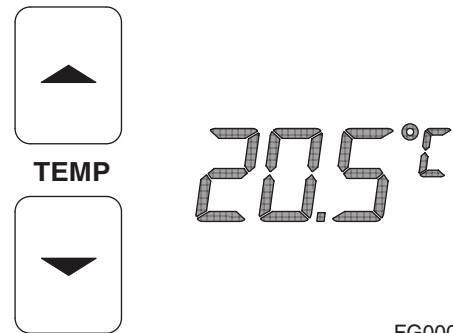

Figure 105

FG000090

4. Temperature Unit Selector Button

This button gives the choice to select either °C or °F.

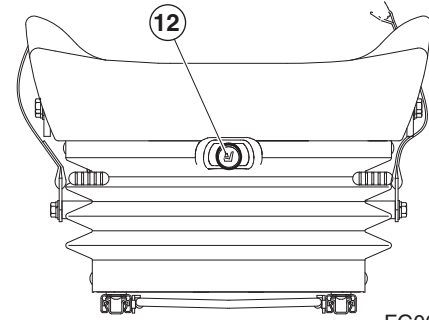

Figure 106

FG000094

12. Air Suspension Seat (Optional)

The operator seat is also available with air suspension for even better comfort. The switch (12, Figure 130) in the middle of the seat can be used to adjust the air cushion. If the switch is pressed, the seat become harder, and pulling it out makes the seat softer, when the air is bleed out.



FG000187

Figure 130

13. Heating the Operator's Seat (Optional)

The air suspension seat can be heated. The switch on the left control stand is used to warm the seat. When heating is not needed or seat is warmed, turn the switch to "OFF" position.

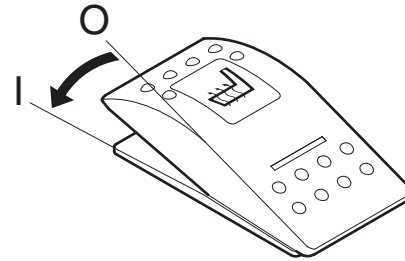

FG000034

Figure 131

Operation

TO HANDLE A NEW EXCAVATOR

All DOOSAN excavators are inspected and adjusted before leaving the factory. However, it is required that the operator follow these steps during the initial break-in period. Failure to follow these steps may result in damage to the equipment or reduced performance.

Hour	Load
For first 50 hours of operation.	Maintain about 80% load of full capacity (Engine rpm: 80% of rated rpm)
After first 50 hours of operation.	Full load

If machine is used at full load before it is broken in, it may affect the life cycle and safe running operations. This could lead to problems later.

- NOTE:**
1. *Check daily for leakage of coolant, fuel, engine oil and hydraulic oil.*
 2. *Inspect all lubricants daily, add appropriate lubricants as required.*
 3. *During operation, monitor all instruments and gauges from time to time.*
 4. *Avoid an extreme engine load.*
 5. *Operate unit at 80% load until engine and all other components are at operating temperature.*
 6. *Check that work equipment is operating normally during operation.*
 7. *Check machine for loose parts or for damage that may have occurred during shipping.*
 8. *Check for loose wiring or terminals, check gauge operation and battery electrolyte level.*

CLICK HERE TO **DOWNLOAD** THE COMPLETE MANUAL

- Thank you very much for reading the preview of the manual.
- You can download the complete manual from: www.heydownloads.com by clicking the link below



- Please note: If there is no response to CLICKING the link, please download this PDF first and then click on it.

CLICK HERE TO **DOWNLOAD** THE COMPLETE MANUAL

5. Set engine speed control dial to "HIGH IDLE" (Figure 20).
6. Repeat Step 4 for five minutes. If working speeds continue to be slow, continue to operate, but use extreme caution because the machine function may be erratic.
7. Check for clearance and fully raise the front attachment. Slowly swing clockwise 3 revolutions. Slowly swing counterclockwise 3 revolutions.
8. Travel forward and reverse at low speed for two revolutions of the drive sprocket.

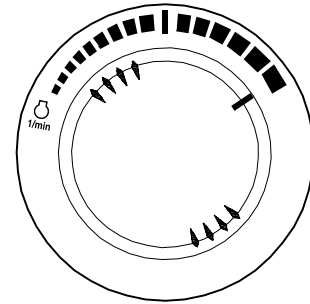

HAOB550L

Figure 20

Engine Shut Down

NOTE: Allow engine to idle for three - five minutes before shutting down the engine. If not allowed to idle, heat surge may develop which will damage the engine. Allowing the engine to idle will dissipate heat.

1. Park excavator on level and firm ground.
2. Lower front end attachment to ground and make sure all operating controls are in "NEUTRAL."
3. Set safety lever on "LOCK" position (Figure 22).

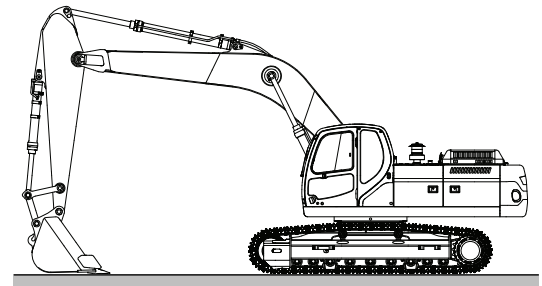

FG000111

Figure 21

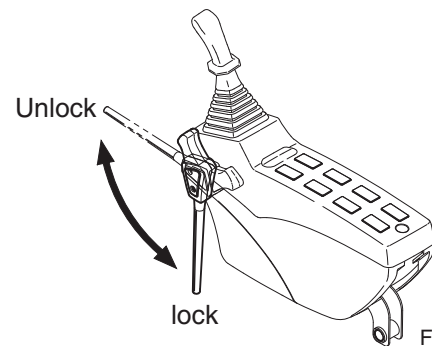

FG001091

Figure 22

4. Set engine speed control dial to "LOW IDLE" (Figure 23). Allow engine to idle for three - five minutes.

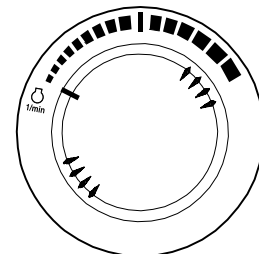

HAOB290L

Figure 23

11. On the rear of left control stand in cabin is a vernier caliper throttle control. The throttle control is a push/pull and/or screw type assembly. The locking collar (7, Figure 44) at base of mechanism must be turned to the released position before the throttle can be adjusted. Turn the locking collar counterclockwise to adjust engine speed by pulling the cable. Turn the locking collar clockwise to fix engine speed after obtained the desired engine speed.

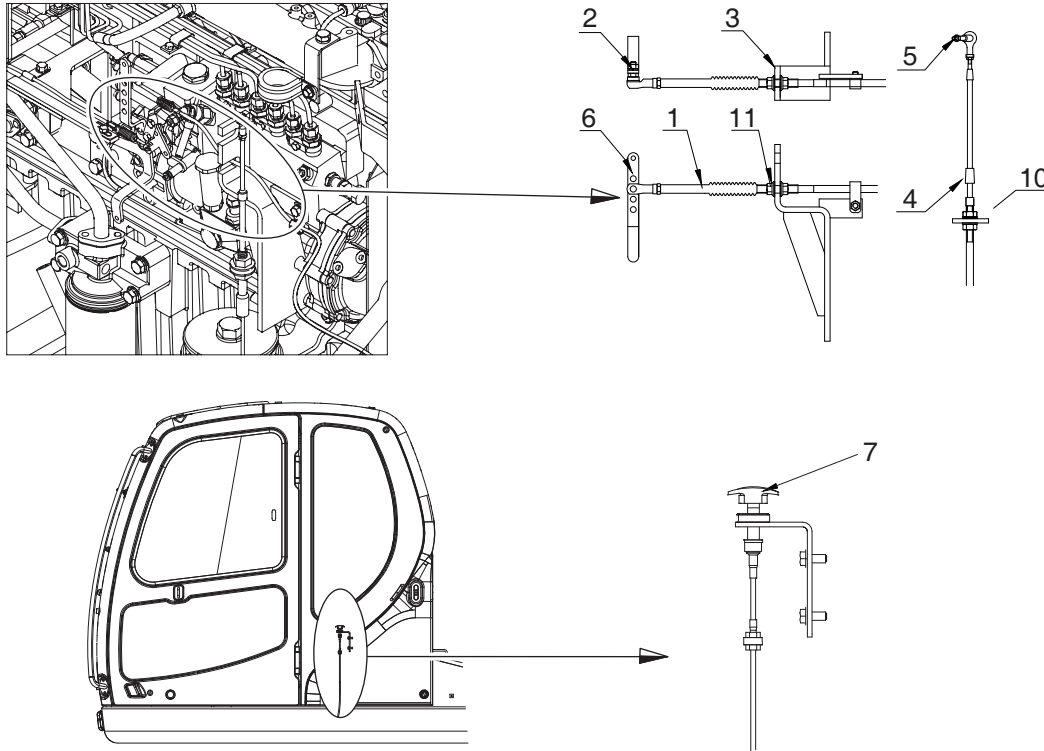

Figure 41

FG014273

Working in Water

IMPORTANT

When working in water, do not exceed a slope of more than 15°. If the slope is over 15°, the rear part of the upper structure will be immersed in water, resulting in radiator fan damage.

When working in water, do not operate in water over center of upper roller (1, Figure 67).

If swing bearing gets wet, immediately grease it until all old grease is purged from bearing.

If water gets into swing gear housing, drain water immediately by removing lower inspection cover. Apply new grease.

After working in water, purge old grease on bucket pins.

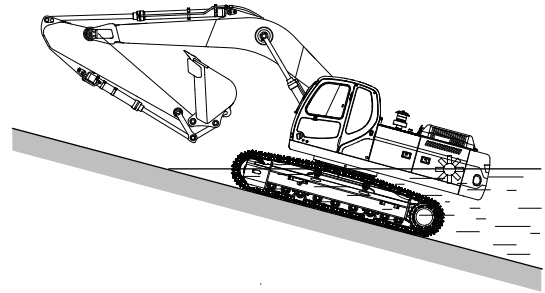

FG000179

Figure 66

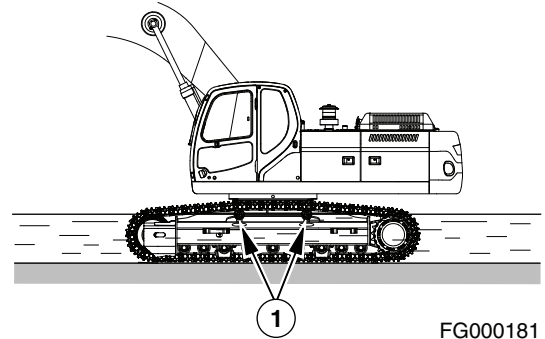

FG000181

Figure 67

Rotating Pedal Valve (Optional)

Attachment Rotating by Using the Pedal Valve

1. Pressing end (1, Figure 87) is used to turn clockwise.
2. Pressing end (2, Figure 87) is used to turn counterclockwise.

NOTE: Before activating the pedal, be sure to check the function of the attachment.

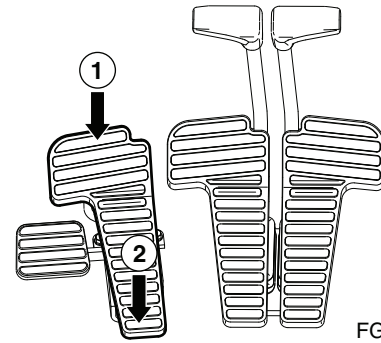

FG000405

Figure 87

Locking the Pedal

When rotating is not needed, the pedal can be locked by using the prop rod (3) locking device.

Locking is completed when the top end of the prop (3) is positioned into pedal hole.

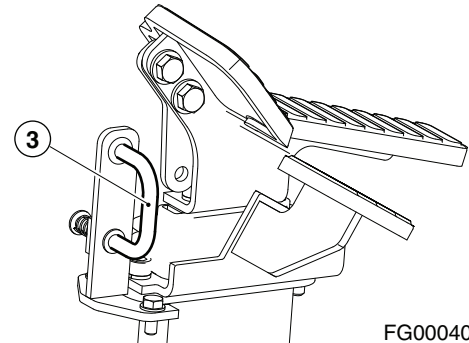

FG000406

Figure 88

- A. Location for "UNLOCKING."
- B. Location for "LOCKING."

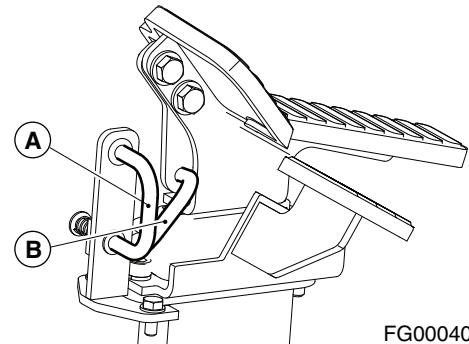

FG000407

Figure 89

Attachment Rotation Using the Left-hand Work Lever (Joystick)

For a machine equipped with an attachment that rotates, rotation is activated while one of the control buttons is being pressed on top of the left-hand work lever (joystick).

There are three buttons on top of the left-hand work lever. The left and right ones are for controlling rotation.

NOTE: The middle button is for the horn.

Left button is for counterclockwise rotation, and the right one is for clockwise rotation.

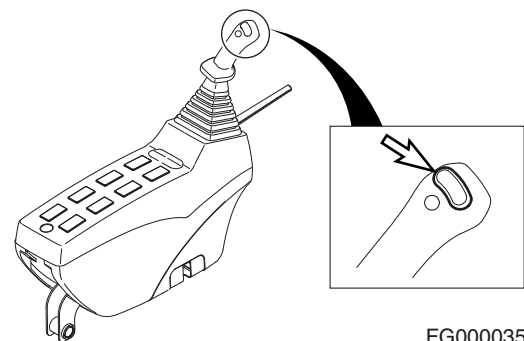

FG000035

Figure 90 LEFT-HAND WORK LEVER (JOYSTICK)

Safety Precautions

1. Make sure to lock out the hydraulic controls and post a notice (Warning Tag) that the machine is being serviced to prevent any unauthorized operation.
2. Make sure to clean up any fluid spills, especially around the engine.
3. Inspect all fuel lines to make sure that fittings, lines, filters and O-rings, etc., are tight and are not showing signs of wear or damage.
4. If the inspection or test procedure requires that the engine be running, make sure to keep all unauthorized personnel away from the machine, and that all industry standard safety precautions are followed.

SERVICE ITEM	PAGE
Change Pilot Filter (After First 250 Hours)	4-31
Inspect Pins and Bushings of the Front End Attachments for Signs of Wear	4-32
Check Fluid Levels in Batteries and Battery Charge Levels	4-32
Inspect for Any Loose or Missing Nuts and Bolts	4-32
Inspect Fuel System Hose Clamps	4-32
500 Hour / 3 Month Service	
Perform All Daily, 50 and 250 Hour Service Checks	4-33
Grease Swing Gear and Pinion	4-33
Change Engine Oil and Filter	4-34
Clean Air-Conditioning Outer Filter	4-35
Check and Clean Air-Conditioning Inner Filter	4-36
Clean Radiator, Oil Cooler, Intercooler, Fuel Cooler and Air Conditioner Condenser Core	4-37
Clean Outer Filter of Air Cleaner	4-38
Clean Water Separator	4-40
Change Fuel Filter	4-41
1,000 Hour / 6 Month service	
Perform All Daily, 50, 250 and 500 Hour Service Checks	4-42
Grease Swing Reduction Device	4-42
Replace Hydraulic Oil Return Filter	4-43
Change Pilot Filter	4-44
Change Oil in Travel Reduction Device (One on Each Side of Unit)	4-45
Change Air Breather Filter	4-45
Change Air-Conditioning Outer Filter	4-46
Check Air Conditioner Refrigerant	4-47
Check and Adjust Engine **	4-47
2,000 Hour / Yearly Service	
Perform All Daily, 50, 250, 500 and 1,000 Hour Service Checks	4-48
Change Swing Reduction Device Oil	4-48
Replace Outer and Inner Air Cleaner Elements	4-49
Change Radiator Coolant	4-50
Hydraulic Oil Exchange and Suction Strainer Cleaning	4-51
Check Alternator and Starter**	4-53
Check All Rubber Antivibration Shock Mounts	4-53
Perform and Record the Results of the Cycle Time Tests	4-53
Inspect Machine to Check for Cracked or Broken Welds or other Structural Damage	4-53
Check, Adjust Valve Clearance **	4-53
Check Head Bolt Torques	4-53
4,000 Hour / Biennial Service	
Major Parts - Periodic Replacement	4-54
12,000 HOUR / SIX YEAR SERVICE	
Hose In-service Lifetime Limit (European Standard ISO 8331 and EN982 CEN)	4-55

** These checks need to be completed by an authorized DOOSAN dealer.

50 HOUR / WEEKLY SERVICE

Perform All Daily Service Checks

Grease Arm and Front Attachment Pins

Grease every 10 hours for first 100 hours and every 50 hours thereafter.

NOTE: *If the unit has been running or working in water the front attachment should be greased on a 10 hour / daily basis.*

- Position machine as shown below and lower the front attachment to the ground and shut down engine
- Press the grease fitting and inject grease with the grease gun on the marked point
- After injection, clean off the old grease that has been purged.

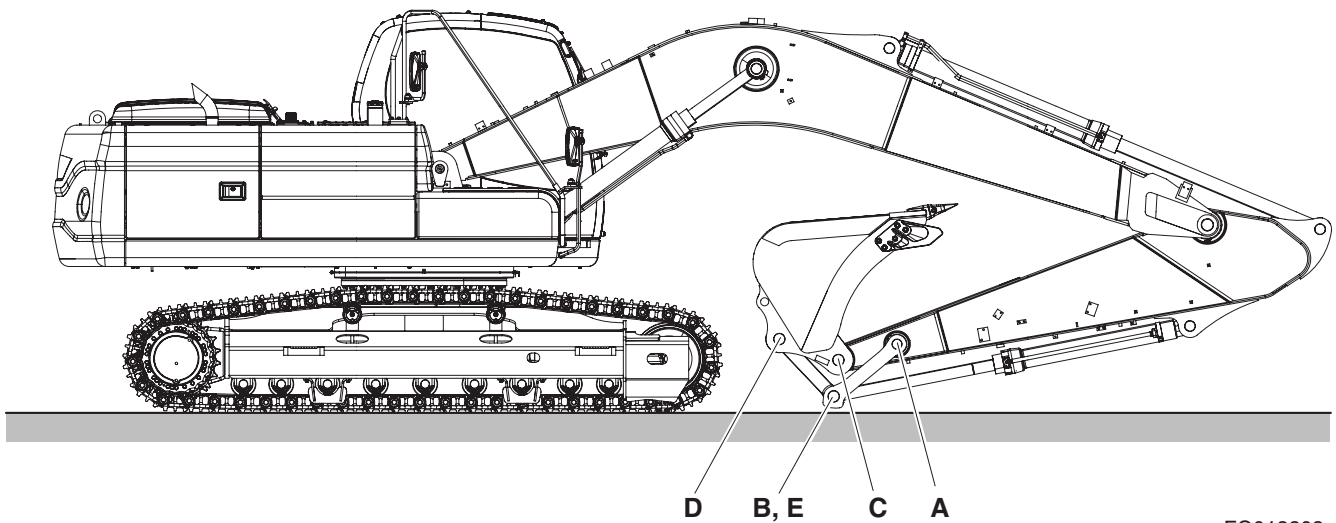

FG013203

Figure 34

Reference Number	Description
A	Arm Link Joint Pin (1 Points)
B	Link Joint Pin (2 Points)
C	Arm Bucket Joint Pin (1 Points)

Reference Number	Description
D	Bucket Link Joint Pin (1 Point)
E	Bucket Cylinder Rod Pin (1 Point)

500 HOUR / 3 MONTH SERVICE

Perform All Daily, 50 and 250 Hour Service Checks

Grease Swing Gear and Pinion



Greasing swing gear and pinion must be serviced by only one person.

1. Remove inspection cover and inspect the condition of the grease. Make sure that water or other contaminants are not noticeable.

NOTE: *The upper structure must be rotated a little at a time so that the entire face of the swing gear can be lubricated. Use extreme caution when performing this operation.*

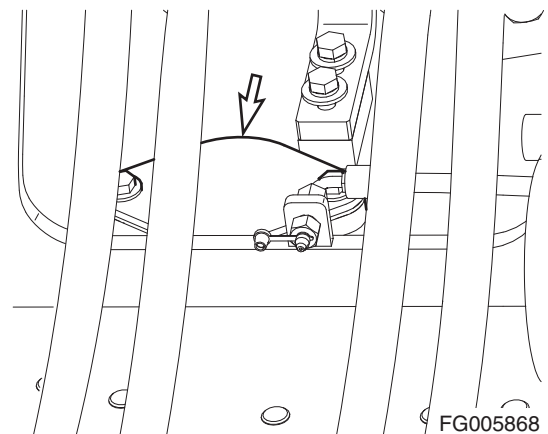

Figure 47

FG005868

2. If water or other contaminations are found, remove the lower access cover so that the gear teeth can be thoroughly cleaned and lubricated.
3. Install access covers after lubricating gear teeth.

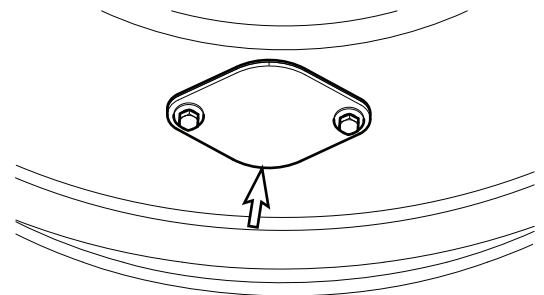

Figure 48

FG000148

Replace Hydraulic Oil Return Filter

NOTE: Change hydraulic oil return filter after first 250 hours of operation or rebuild, and every 1,000 hours thereafter.

NOTE: If return filter clogged warning light (Figure 71) on instrument panel comes "ON" the return filter must be serviced.

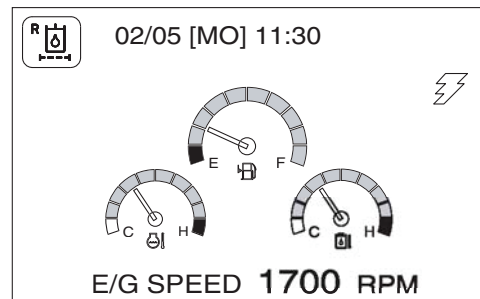

FG000760

Figure 71

WARNING!

The hydraulic oil will be hot after normal machine operation. Allow the system to cool before attempting to service any of the hydraulic components.

The hydraulic tank is pressurized. Lift the hydraulic breather cap slightly to allow the pressurized air to vent. After the pressure has been released, it is safe to remove either the fill cap or service covers or drain water from the tank.

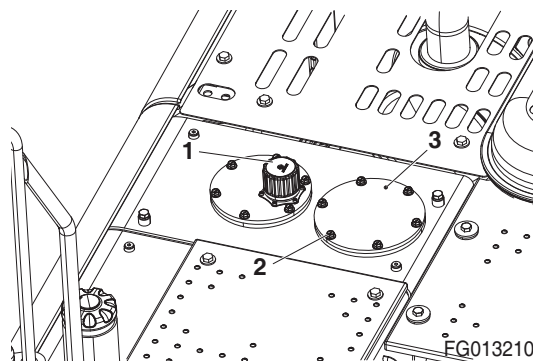

Figure 72

IMPORTANT

Make sure to clean any dirt or water from the top of the hydraulic tank, especially around the fill port and filter ports.

1. Position the machine on firm, level ground. Lower the front attachment to the ground and shut down engine.
2. Lift the breather cap (1, Figure 72) slightly to release the internal pressure.
3. Remove bolts (2, Figure 72) and service cover (3). Remove spring (4), valve (5) O-ring (6), and bypass strainer (7), and then filter (8).

4. Remove filter and discard.

NOTE: Used filter should always be disposed of according to local regulations.

5. Install new filter and a new O-ring. Install bypass strainer, valve and spring. Install service cover plate.
6. Tighten the breather cap (1, Figure 72).
7. Run engine for ten minutes at low idle to purge air from circuit.
8. Check level in hydraulic oil tank (See page 4-15). Add oil if necessary.

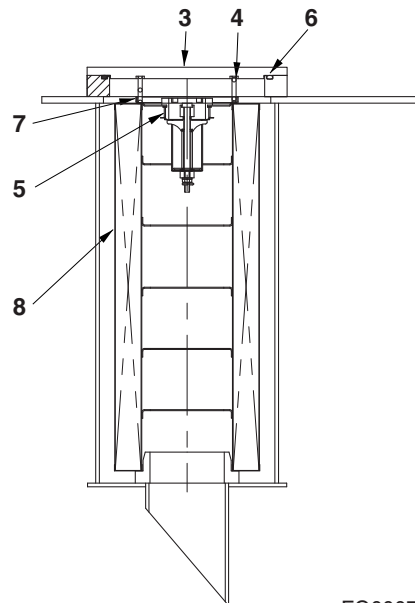

FG000761

Figure 73

10. Fill the hydraulic oil tank. Check level using sight gauge on side of tank.
11. Place spring (3, Figure 97) on rod (4) and assemble cover (2).
12. After replacing and cleaning the hydraulic oil, filter and strainer, vent the system. See "Venting and Priming Hydraulic System" on page 4-80.

IMPORTANT

When the hydraulic breaker is being used, due to the higher heat generated by this unit, use replacement intervals recommended under the "Hydraulic Oil and Filter Service Intervals" on page 3-38.

13. Check level of hydraulic oil tank. (See page 4-15)

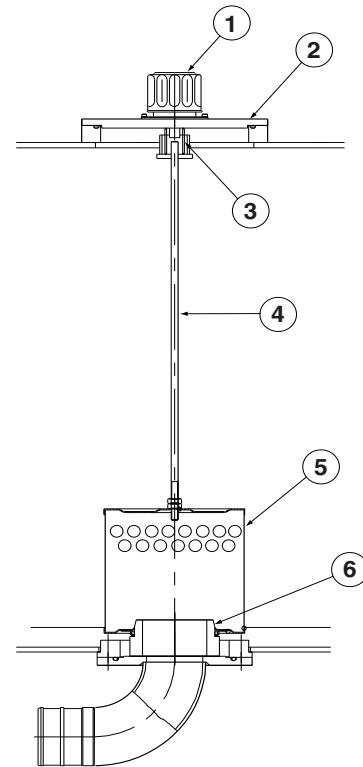

Figure 97

ARO1720L

Check Alternator and Starter**

**These checks need to be completed by an authorized DOOSAN dealer.

Check All Rubber Antivibration Shock Mounts

Perform and Record the Results of the Cycle Time Tests

Inspect Machine to Check for Cracked or Broken Welds or other Structural Damage

Check, Adjust Valve Clearance **

Check Head Bolt Torques

16. Tightening bolt for track guard

- Tool: 24 mm ()
- Torque: 27 kg•m (265 N•m, 195 ft lb)

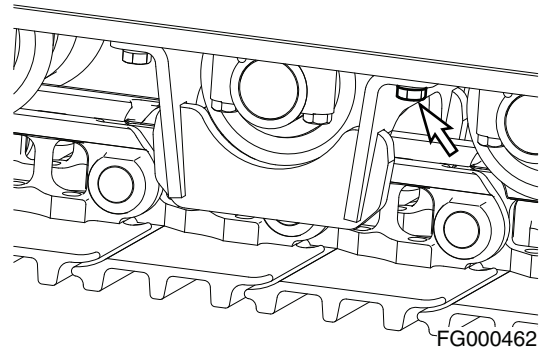



Figure 118

17. Bolt for track shoes

- Tool: 27 mm ()
- Torque: 78 kg•m (765 N•m, 564 ft lb)

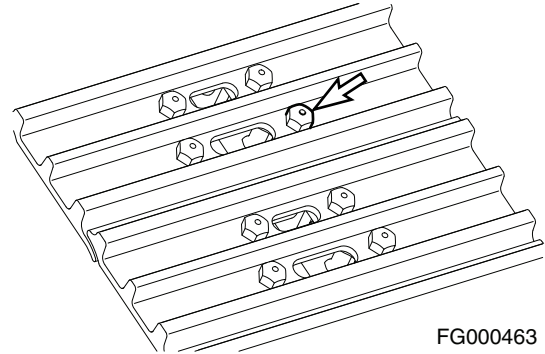



Figure 119

18. Fixing bolt for front pin

- Tool: 24 mm ()
- Torque: 27 kg•m (265 N•m, 195 ft lb)

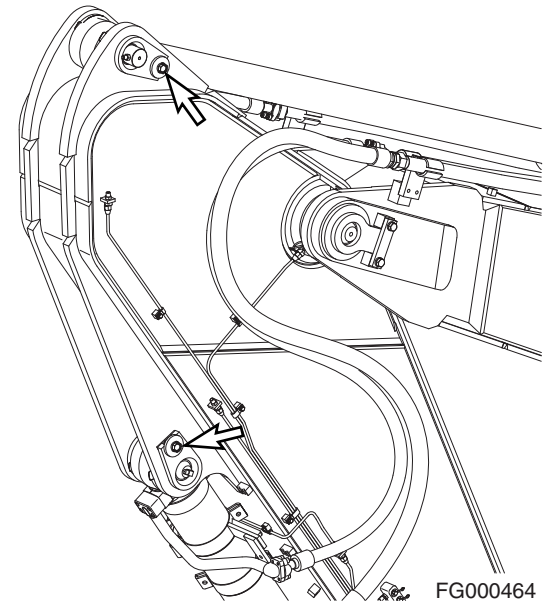

Figure 120

Types of Antifreeze

There are two main classifications of antifreeze available on the market today.

1. Ethylene Glycol - Standard Life Antifreeze
2. Propylene Glycol - Extended Life Antifreeze

Ethylene glycol (standard life antifreeze) has been on the market for many years. Its chemical properties do not provide the improved corrosion resistance that propylene glycol (extended life antifreeze) does. Ethylene glycol is also very hazardous to the environment, people and animals. *DOOSAN* recommends that ethylene glycol be replaced with propylene glycol.

The newer propylene glycol antifreeze comes in many different colors. Some of the colors are pink, red, orange and yellow. There are even some that come in a blue-green color. The blue-green color makes it very difficult to tell the difference of what type of antifreeze is in a cooling system. The colors are only a dye added to the clear antifreeze. Do not rely on color. Keep careful machine records of what brand and type of antifreeze is used in the unit. If you are unsure of what type of antifreeze is in the system, drain and flush the system.

NOTE: *Do not mix ethylene glycol and propylene glycol antifreeze together. If the two are mixed, the protection level will be reduced to the level of the ethylene glycol.*

Antifreeze Concentration Tables

Ethylene Glycol - Standard Life Antifreeze (1,000 Hour / 6 Months)		
Ambient Temperature	Cooling Water	Antifreeze
-10°C (14°F)	80%	20%
-15°C (5°F)	73%	27%
-20°C (-4°F)	67%	33%
-25°C (-13°F)	60%	40%
-30°C (-22°F)	56%	44%
-40°C (-40°F)	50%	50%

Propylene Glycol - Extended Life Antifreeze (2,000 Hour / Yearly)		
Ambient Temperature	Cooling Water	Antifreeze
-10°C (14°F)	78%	22%
-15°C (5°F)	71%	29%
-20°C (-4°F)	65%	35%
-25°C (-13°F)	59%	41%
-30°C (-22°F)	55%	45%
-40°C (-40°F)	48%	52%

MAINTENANCE IN SPECIAL CONDITIONS

NOTE: See "Operation Under Unusual Conditions" on page 3-44 for other recommendations.

Conditions	Maintenance Required
Operating in mud, water or rain.	Perform a walk around inspection to check for any loose fittings, obvious damage to the machine or any fluid leakage.
	After completing operations, clean mud, rocks or debris from the machine. Inspect for damage, cracked welds or loosened parts.
	Perform all daily lubrication and service.
	If the operations were in salt water or other corrosive materials, make sure to flush the affected equipment with fresh water.
Operating in an extremely dusty or hot environment.	Clean the air intake filters on a more frequent basis.
	Clean the radiator and oil cooler fins to remove embedded dirt and dust.
	Clean the fuel system intake strainer and fuel filter more frequently.
	Inspect and clean as required the starter and alternator.
Operating in rocky terrain.	Check the undercarriage and track assemblies for damage or excessive wear.
	Inspect for loose or damaged fittings or bolts.
	Relax track tension.
	On a more frequent basis, inspect the front end attachments for damage or excessive wear.
	Install a top guard and front guard as required for protection against falling rock.
Operating in extreme cold.	Use the proper fuel for the temperature conditions.
	Using a hydrometer, check the antifreeze to make sure that it is providing the proper cold weather freeze protection.
	Verify the condition of the batteries. In extremely cold weather remove the batteries at night and store them in a warmer area.
	Remove mud buildup as soon as possible to prevent it from freezing to the undercarriage and causing damage.

Problem	Cause	Remedy
Engine runs hot.	Low coolant level.	Add coolant.
	Thermostat faulty.	Replace thermostat.
	Radiator cap faulty.	Replace radiator cap.
	Radiator core plugged.	Clean radiator.
	Oil cooler core plugged.	Clean oil cooler.
	Fan belt loose or damaged.	Tighten or replace as required.
	Temperature sensor faulty.	Replace sensor.

HYDRAULIC SYSTEM

Problem	Cause	Remedy
None of the controls function (loud noise from pumps).	Hydraulic pump failed.	Contact your <i>DOOSAN</i> dealer.
	Low hydraulic oil level.	Add hydraulic oil as required.
	Suction line plugged or damaged.	Clean or replace as required.
None of the controls function (no noise from pumps).	Pilot pump failure.	Contact your <i>DOOSAN</i> dealer.
	Cut off solenoid valve failed.	Replace solenoid.
	Pilot cutoff switch is ON.	Adjust pilot cutoff switch clearance.
All actuators have low power.	Low hydraulic oil level.	Add hydraulic oil as required.
	Suction filter clogged.	Clean filter.
	Hydraulic pumps faulty.	Contact your <i>DOOSAN</i> dealer.
	Main relief pressure too low.	Contact your <i>DOOSAN</i> dealer.
	Hydraulic pumps excavating.	Bleed air from hydraulic pumps.
Only one or two actions have little or no power.	Overload relief pressure too low.	Reset pressure.
	Makeup check valve leaking.	Clean or replace as required.
	Control valve spool faulty.	Replace valve spool.
	Dirt in valve spool.	Clean or replace as required.
	Actuator failed.	Repair or replace as required.
	Cylinder seal failed.	Repair or replace as required.
	Cylinder rod damaged.	Repair or replace as required.
	Remote control valve failed.	Replace control valve.
	Wrong pilot line connection.	Reconnect pilot lines.
Oil temperature too high.	Oil cooler faulty.	Contact your <i>DOOSAN</i> dealer.
	Fan belt loose.	Tighten fan belting as required.

CLICK HERE TO **DOWNLOAD** THE COMPLETE MANUAL

- Thank you very much for reading the preview of the manual.
- You can download the complete manual from: www.heydownloads.com by clicking the link below



- Please note: If there is no response to CLICKING the link, please download this PDF first and then click on it.

CLICK HERE TO **DOWNLOAD** THE COMPLETE MANUAL