



BI015770  
October 2014



# Operation and Maintenance Manual

---

6090ACFS  
Hydraulic Shovel

No. DHS90011

---



CLICK HERE TO **DOWNLOAD** THE COMPLETE MANUAL

- Thank you very much for reading the preview of the manual.
- You can download the complete manual from: [www.heydownloads.com](http://www.heydownloads.com) by clicking the link below



- Please note: If there is no response to CLICKING the link, please download this PDF first and then click on it.

CLICK HERE TO **DOWNLOAD** THE COMPLETE MANUAL

NOTES	3-101
<b>4 REPAIR WORK</b>	<b>4-1</b>
SAFETY INSTRUCTIONS FOR EXCAVATORS WITH ELECTRIC MOTOR	4-3
REPAIR WORK - SAFETY INSTRUCTIONS	4-5
FIRE AND EXPLOSION HAZARD	4-7
HYDRAULIC SYSTEM	4-8
Repair	4-8
Hydraulic hoses – Instructions	4-8
PRESSURE ACCUMULATORS - SAFETY INSTRUCTIONS	4-9
WELDING OPERATIONS - SAFETY INSTRUCTIONS	4-10
NOTES	4-11
<b>5 ANNEX</b>	<b>5-1</b>
TROUBLESHOOTING	5-3
Instructions on troubleshooting	5-3
Layout of the fault table	5-3
Possible causes	5-3
Measures	5-3
Section	5-3
FAULT TABLES	5-4
Working hydraulics – Fault table	5-4
Track drive – Fault table	5-5
Swing mechanism – Fault table	5-6
Central lubricating system – Fault table	5-7
HYDRAULIC CIRCUIT DIAGRAM	5-8
ABBREVIATIONS	5-9
TECHNICAL DATA	5-11
NOTES	5-13
<b>6 INDEX</b>	<b>6-1</b>



Always keep a distance from the working face and from slopes.

Avoid any operation that might be a risk to machine stability.

Never travel across slopes; always keep the working equipment and the load close to the ground, especially when travelling downhill.

On sloping terrain always adapt your travelling speed to the prevailing ground conditions.

Before leaving the driver's seat always secure the machine against inadvertent movement and unauthorized use. Shut off the engines.

## **Special work in conjunction with utilization of the machine and maintenance and repairs as well as troubleshooting during work; disposal of parts and consumables**

Observe the adjusting, maintenance and inspection activities and intervals set out in the operating instructions, including information on the replacement of parts and equipment. These activities may be executed by skilled personnel only.

Brief operating personnel before beginning special operations and maintenance work, and appoint a person to supervise the activities.

In any work concerning the operation, conversion or adjustment of the machine and its safety-oriented devices or any work related to maintenance, inspection and repair, always observe the start-up and shut-down procedures set out in the operating instructions and the information on maintenance work.

Ensure that the maintenance area is adequately secured.

If the machine is completely shut down for maintenance and repair work, it must be secured against inadvertent starting by:

- removing the ignition key and
- attaching a warning sign.

Carry out maintenance and repair work only if the machine is positioned on stable and level ground and has been secured against inadvertent movements.

To avoid the risk of accidents, individual parts and large assemblies being moved for replacement purposes should be carefully attached to lifting tackle and secured. Use only suitable and technically perfect lifting gear and suspension systems with adequate lifting capacity. Never work or stand under suspended loads.

The fastening of loads and the instructing of crane operators should be entrusted to experienced persons only. The marshaller giving the instructions must be within sight or sound of the operator.

For carrying out overhead assembly work always use specially designed or otherwise safety-oriented ladders and working platforms. Never use machine parts as a climbing aid

## 2 OPERATION

	Operating instructions	Target group
Part 1	<b>INTRODUCTION</b> <b>FUNDAMENTAL</b> <b>SAFETY INSTRUCTIONS</b>	<b>Operating personnel</b> + <b>Inspection and servicing personnel</b> + <b>Repair personnel</b>
<b>Part 2</b>	<b>OPERATION</b>	<b>Operating personnel</b>  The operating personnel must have know-how relevant to the operation and the application of this or comparable machines.
Part 3	<b>INSPECTION AND SERVICING</b>	<b>Inspection and servicing personnel</b>  The inspection and servicing personnel must have know-how relevant to the inspection and servicing of this or comparable machines.
Part 4	<b>REPAIR WORK</b>	<b>Repair personnel</b>  The repair personnel must have know-how and experience relevant to the repair of this or comparable machines.
Part 5	<b>ANNEX</b>	<b>Operating personnel</b> + <b>Inspection and servicing personnel</b> + <b>Repair personnel</b>
Part 6	<b>INDEX</b>	<b>Operating personnel</b> + <b>Inspection and servicing personnel</b> + <b>Repair personnel</b>



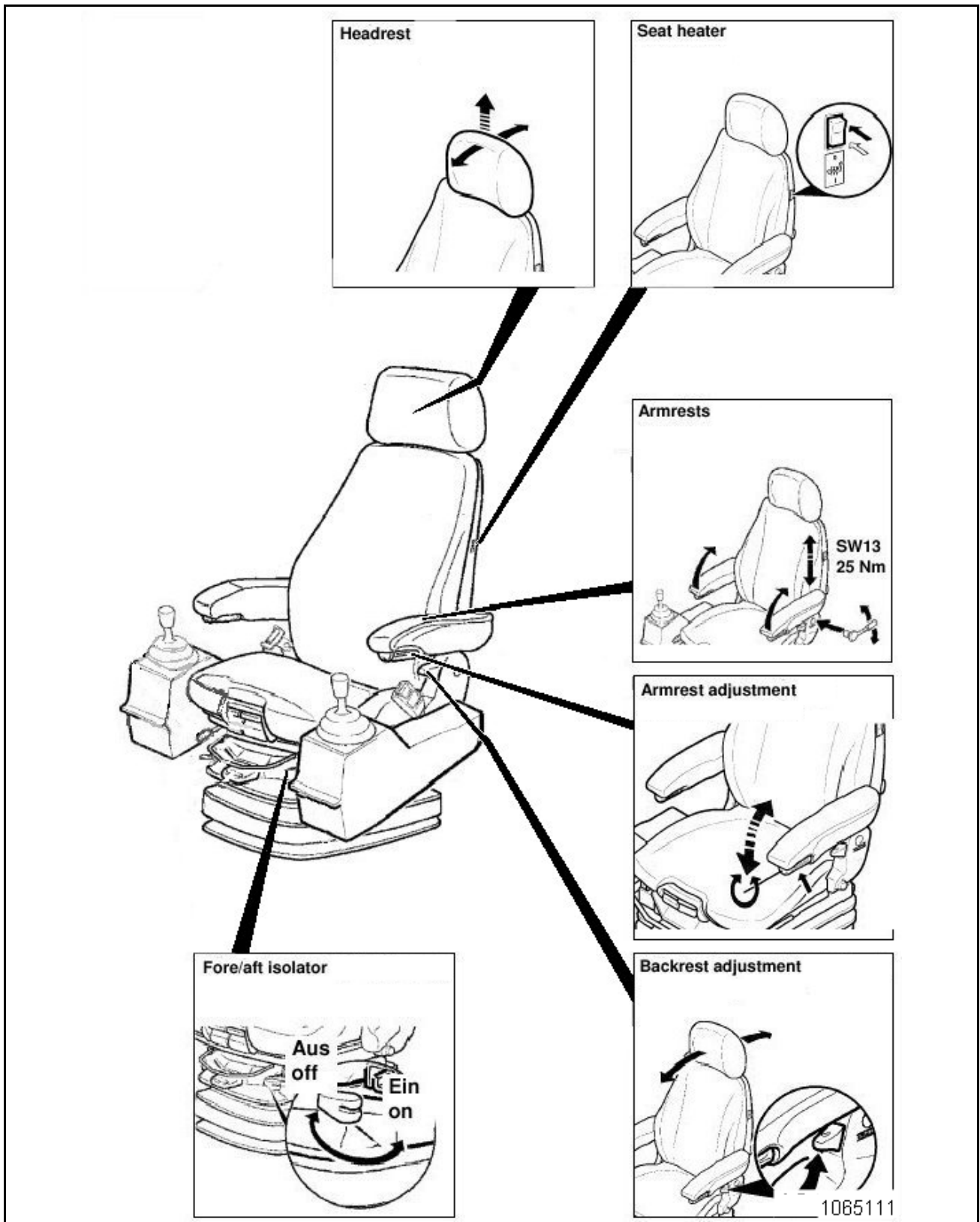













Fig. 2-27:

(Fig. 2-42)

No.	Element	Function	Symbol
30	Lamp	Illuminates the front side of the control column.	
31	Pushswitch <b>Emergency OFF</b>	<p>The entire electrical system is interrupted in all poles by the on-board circuit breaker.</p> <p> <b>Even after actuation of the EMERGENCY STOP switch, medium voltage (6.6 KV) is present (primarily) from the transformer station via drag cable and slip ring assembly to the circuit breaker.</b></p>	
32	Key-switch	Switches the low voltage system on and off.	
33	Buzzer	<p><b>Gives an acoustic warning signal if a fault is reported</b></p> <ul style="list-style-type: none"> <li>▪ Electric motor <ul style="list-style-type: none"> <li>– winding temperature too high</li> <li>– bearing temperature too high</li> </ul> </li> <li>▪ bord transformer temperature too high</li> <li>▪ Hydraulic oil level too low</li> <li>▪ Distributor gearbox temperature too high</li> <li>▪ Swing pump temperature (1 and / or 2; too high</li> <li>▪ Swing gearbox temperature (1 and / or 2) too high</li> <li>▪ Fault in lubricating system</li> </ul> <p> <b>Lower the equipment to the ground and switch off electric motor immediately if the buzzer (33) sounds and the BCS indicates a fault. The buzzer (33) continues to sound until the fault has been retified.</b></p>	

(Fig. 2-47:)

No.	Element	Function	Symbol
91	Switch <b>Emergency Operati- on Boom/Stick</b>	Actuate and hold if boom and stick must be lowered in an emergency.	
92	Button <b>Dumper count</b>	RESET	
93	Switch	Activates boom cylinder limit switch (optional)	
94	Button	When switched it is possible to swing the uppercarriage and to drive the excavator even when the hydraulic ladder or the service station is in the lower position.   <b>Risk of damaging the ladder or the service station!</b>  <b>Be careful and swing the uppercarriage and drive the excavator very slowly and only a short way.</b>	
95	Switch <b>Lighting</b>	Switches on the lighting for servicing work.	
96	Switch <b>Lighting</b>	Switches the cab lighting on and off.	
97	Switch <b>Windscreen wiper rear window (op- tional)</b>	Activates permanent wiping.	
98	Switch <b>Beacon (optional)</b>	Switches the beacon on and off.	

## Switching the electric motors on and off

### Before switching on the electric motors

**⚠ Before switching on the electric motors, check that nobody is working on the electrical system or on the excavator itself.**

**Switch on the electric motors only when all these work on the excavator is finished and all persons leave the danger area.**

- Switch on battery main switch (see: "Battery main switch, switching on and off").
- Switch on electrical system (24V) (see: "Electrical system (24V), switching on and off").
- Check telltales (14, 16 and 17, Fig. 2-58:), they must lit up in green colour. If so, electric motors can be switched on one after the other (see: "Switching the electric motors on").

If telltales didn't lit up in green colour, BCS has detected critical operating conditions or faults which prohibit starting the electric motors. BCS indicates this case with telltales (for instance 15, 16 and 18, Fig. 2-58:) as well as by displaying corresponding text.

### Switching the electric motors on

- Actuate switch-key (51, Fig. 2-59:), the left electric motor is switched on.
- Wait 10 seconds.
- Actuate switch-key (61, Fig. 2-59:), the right electric motor is switched on.

During starting period the electric motor heavily warm up. Therefore it is not allowed to switch it on and off at will. By means of an electronical time-out circuit (PLC) the electric motors can be switched on only three times a hour (time-out period is 30 minutes).

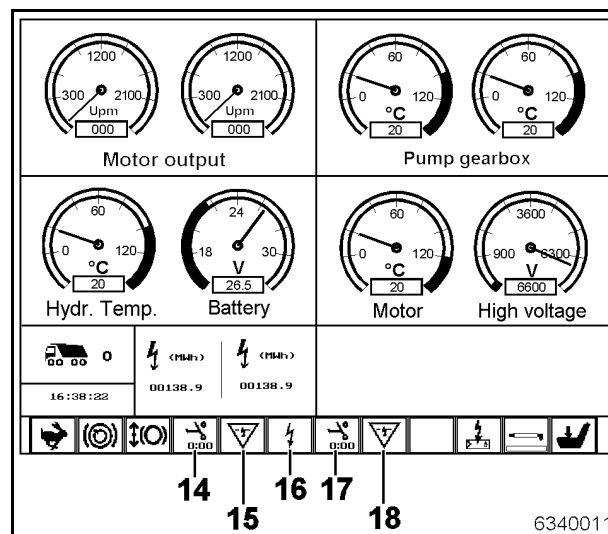

Fig. 2-58:

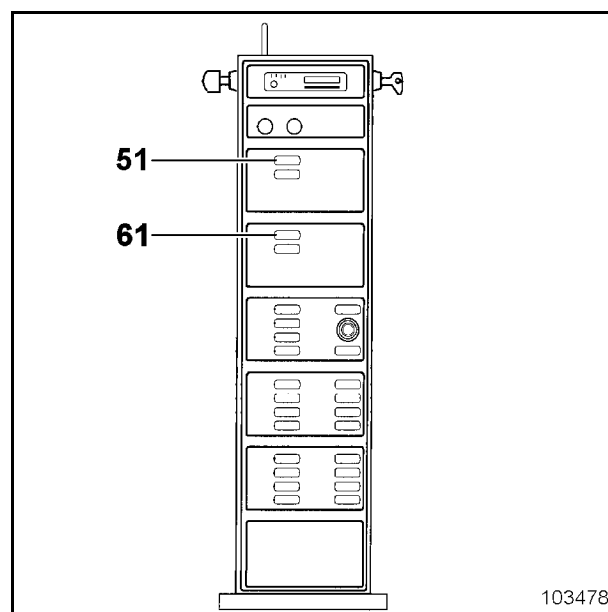

Fig. 2-59:

## Cornering

To take a right-hand corner forwards:

- depress only pedal (112, Fig. 2-77:) forwards.

To take a lefthand corner forwards:

- depress only pedal (113) forwards.

## Turning

To turn to the right:

- depress pedal (112) forwards and pedal (113) backwards.

To turn to the left:

- depress pedal (113) forwards and pedal (112) backwards.

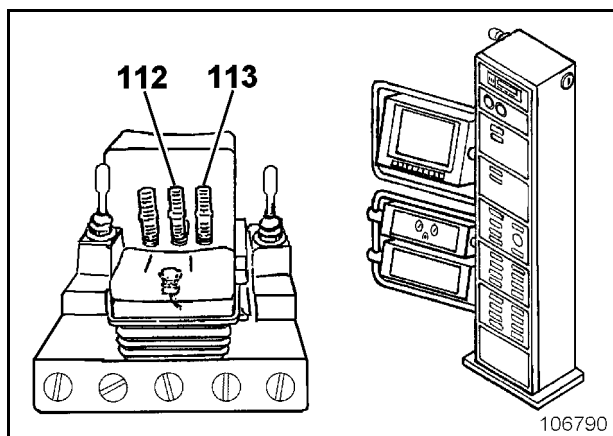

Fig. 2-77:

## Note

Change the position of the undercarriage - parallel or perpendicular to the working face - only by cornering forwards/backwards (Fig. 2-78:).

Cornering to the left:

forwards from pos. 1 to pos. 2

backwards from pos. 2 to pos. 3

forwards from pos. 3 to pos. 4

The same procedure should be adopted if the excavator is to be driven out of depressions (Fig. 2-79:):

Cornering to the left from pos. 1 to pos. 2

Cornering to the right from pos. 2 to pos. 3



**Never use the working equipment to raise one side of the undercarriage and then turn the undercarriage by initiating the swing and/or the travelling function.**

This way of working is contrary to the excavator's designated use.

There is a risk of accident. Moreover, the tracks, swing gear, roller bearing swing ring, backhoe or bucket back-wall and the front part of the bucket are subjected to inadmissibly high stresses.

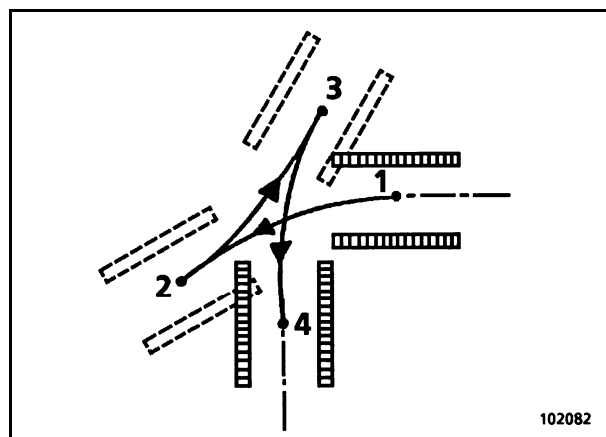

Fig. 2-78:

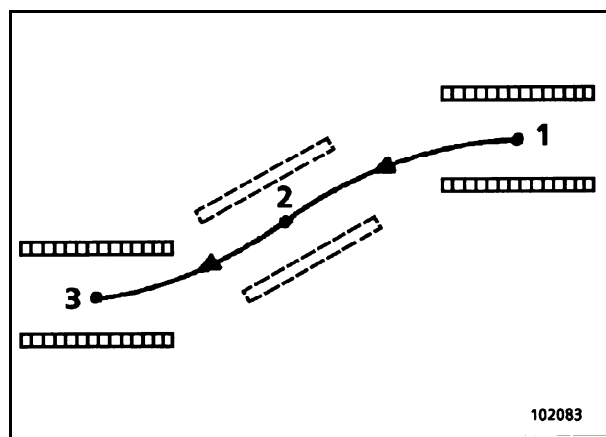

Fig. 2-79:



### **Securing the machine**

Carry out work on the attachment only if the machine is secured as described in the "Securing the machine" section.

Securing the machine

Selecting the attachments

The machine can be equipped with various attachments. The components of the attachments are assembled with hydraulic cylinders and connectors. Components can be combined in various ways for optimum adaptation of the attachments to the specific application.

Operate the machine only with the equipment and component combinations expressly approved by Terex O&K for this type of machine.

Never install and commission other equipment and component combinations without Terex O&K first having inspected and approved the project in writing.

### **Protective roof against falling objects**

The machine is equipped with an integrated cab-protection roof (FOPS).



## **INSPECTION AND SERVICING - SAFETY INSTRUCTIONS**

### **Operating manual**

No inspection and servicing work must be carried out until the operating manual has been read and understood.

Pay special attention to:

Fundamental safety instructions" and all warnings and safety instructions attached to the machine.

The operating manual lists all jobs to be done. The descriptions of job sequences, however, provide only

Experienced personnel with the necessary instructions.

The operating manual must be kept with the machine at all times.

### **Inspection and servicing personnel**

Inspection and servicing personnel must have the necessary know-how on the inspection and servicing of this or comparable machines.

The necessary know-how can be acquired in a several day's instruction, e.g. by an Terex O&K mechanic or by attending an Terex O&K training course.

### **Personal protective equipment and working clothing**

Wear closely fitting working clothing when working on the machine. Loose, wide garments may catch on machine parts and result in injury.

Wear a safety helmet, safety footwear, gloves and, in the event of high noise levels, ear protectors.

### **Securing the working equipment**

Stand working equipment on the ground in such a way that no movements can be made if mechanical or hydraulic connections become detached.

Secure any equipment or component which is to be mounted or dismantled, or whose position is to be changed, with hoists or appropriate slinging / supporting devices to prevent them from moving, slipping or falling inadvertently.

### **Securing the machine**

Carry out servicing work only if the machine is secured as described in the section "Securing the machine".

### **Climbing onto and off the machine**

Use only the ladders, steps, platforms and handrails provided when climbing onto or off the machine.

Always keep ladders, steps, platforms and handrails in a non-slip, safe state and remove any oil, grease, soil, clay, snow, ice and other foreign matter immediately.

Always face the machine when climbing on and off.

### **Checking the state of tools**

Use only fully functional, reliable tools.

Select the right tool for the job.

Wrenches of the wrong size, for example, may slip and cause injury.

CLICK HERE TO **DOWNLOAD** THE COMPLETE MANUAL

- Thank you very much for reading the preview of the manual.
- You can download the complete manual from: [www.heydownloads.com](http://www.heydownloads.com) by clicking the link below



- Please note: If there is no response to CLICKING the link, please download this PDF first and then click on it.

CLICK HERE TO **DOWNLOAD** THE COMPLETE MANUAL

## Plan V

Plan V - Once prior to initial commissioning

Page 1 of 2

Location	Servicing work	Quantity/ No.
<b>Electric motor</b>	Lubricate Check direction of rotation (see electric motor manufacturer's servicing instructions)	2 x 2
<b>Electrical system</b>		
Battery	Check liquid level	2
Lighting	Check operation	
Terminals	Check for tightness	
Slip ring assembly	Visual inspection	1
- Greasing nipples	Grease	
Switchgear cabinets	Check for condensation/drain off water	
<b>Monitoring, warning and control elements</b>	Check function of monitoring, warning and control elements	
	Check emergency OFF function	3
BCS	Check function	1
<b>Hydraulic system</b>	Check function of working and travelling movement	
	Check pressure (see Technical handbook)	
Hydraulic oil reservoir	Check oil level	1
Hydraulic cylinders	Vent (see chapter "venting hydraulic system")	
<b>Pump transfer gearbox</b>	Check oil level	2
- Expansion reservoirs	Check oil level	2
<b>Swing gearbox</b>	Check oil level	6
<b>Travel gearbox</b>	Check oil level	2
- Pre-chambers	Check oil level	2 x 1
- Brake-chambers	Check oil level	2 x 2
<b>Swing ring</b>		
Internal gearing	Check grease filling	1
<b>Undercarriage</b>		
Track roller	Check for leaks and free movement	2 x 7
Support roller	Check for leaks and free movement	2 x 2
Track	Check pressure	2
Idler	Check for leaks and free movement	2

Plan A - after every 250 OH  
(at 250, 750, 1250 ... OH)

Plan B - after every 500 OH  
(at 500, 1500, 2500 ... OH)

Plan C - after every 1000 OH  
(at 1000, 2000, 3000, 4000 ... OH)

Plan D - after every 5000 OH  
(at 5000, 15000, 25000 ... OH)

Plan E - after every 10000 OH  
(at 10000, 20000, 30000, ... OH)

Location	Servicing work	Menge / No.	Plan A	Plan B	Plan C	Plan D	Plan E
<b>Swing ring</b> Gearing / pinion Fastening screws (swing ring, undercarriage and super-structure)	Check grease filling	1		●	●	●	●
	Check condition			●	●	●	●
	Check for tightness (see Technical Handbook)						●
<b>Undercarriage</b> Diaphragm accumulator	Check wear (see Technical Handbook)				●	●	●
	Check pressure (see Technical handbook)	2					●
<b>Central lubricating system</b> Oilfilter (hydraulic circuit grease pump) Grease filter (filling grease container) Grease filter (grease lines) Breather filter	Check function			●	●	●	●
	Check for contamination and damage	1			●	●	●
	Replace	1					●
	Check for contamination and damage	1			●	●	●
	Replace	1					●
	Check for contamination and damage	2			●	●	●
	Replace	2					●
Check / change	1			●	●	●	
<b>Air conditioner (optional)</b> - Filter mats	(see "Air Conditioning manual")				●	●	●
	Change				●	●	●
Ladder - central greasing point	Grease	1			●	●	●

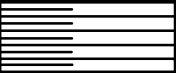

## II. Oils for hydraulic system (selection)

Ambient temperature	°F	-58	-40	-22	-4	+14	+32	+50	+68	+86	+104	+122
	°C	-50	-40	-30	-20	-10	0	+10	+20	+30	+40	+50
<b>Specifications:</b> HVI DIN 51524-3 FZG Test $\geq 11$  V -20°C max. 2500 mm <sup>2</sup> /s  V 80°C (Working temperature) min. 10 mm <sup>2</sup> /s  Shear loss: < 15 %												
	 <b>TM Long Term Hydraulic Fluid HSS</b> <b>Terex O&amp;K SN 3 696 021</b>											

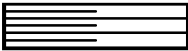
**Warming – up phase necessary before commencing operation.**  
**Warm up hydraulic system for approx. 10 minutes, running at half speed and with repeated actuation of control valves.**

**Oils for lower temperatures can be quoted on request.**

8002111

Fig. 3-10:

## Charging the batteries

The batteries are charged by the battery charger only if the electrical system with the circuit breaker is switched on.

## Removing and installing the battery



Read and observe the "Inspection and servicing – Safety instructions" chapter.

Wear protective gloves and firm working clothing.

Switch off the electric motors before removing the batteries.

Turn key in key-switch to position "0" and withdraw.

Set battery main switch to "OFF" position.

Disconnect and reconnect the terminal clamping lugs in the prescribed order.

Disconnecting and connecting in the wrong order may cause short-circuits.

The batteries (1, Fig. 3-23:) are located in the pedestal. The 12-volt batteries are connected in series and in parallel, so that the system voltage is 24 volts.

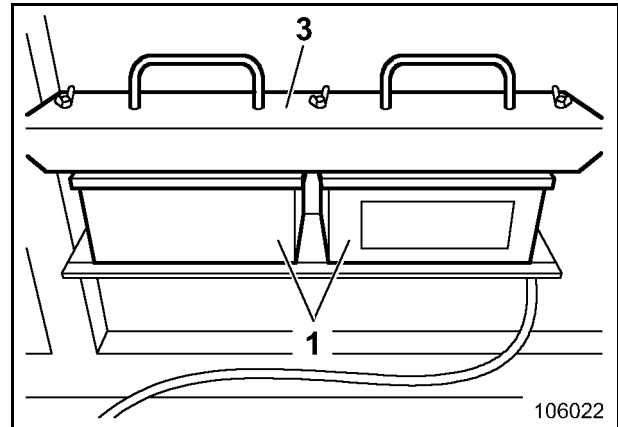

Fig. 3-23:

- Detach battery holder (3).
- Disconnect the cable lug from the negative terminal of the battery.
- Disconnect the cable lug from the positive terminal of the battery.
- Insulate the cable lugs.
- Lift battery out of battery box.

Before installing new batteries, the contact faces of the battery terminal posts and the cable lugs must be cleaned down to the bright metal.

- Install the new batteries.
- Connect the cable lug to the positive terminal of the battery. Tighten the clamping screws of the cable lugs. Do not use too much force to avoid deformation.
- Connect the cable lug to the negative terminal of the battery.
- Apply special terminal grease or acid-free vaseline on the battery terminal posts and clamping lugs. Loose or corroded clamping lugs will lead to alternator or regulator overloading.

## OPERATING INSTRUCTIONS RH 400

### Inspection and servicing

- Loosen screws (13, Fig. 3-42:) and take off spring clip (14) and disk (15).
- Remove basket (12) and clean in paraffin oil.
- Install basket (12).
- Insert filter element (9) together with sealing ring (11) and cap (8) with sealing ring (10).
- Refit cover (3).
- Clean the magnetic rod  
The magnetic rod is located under cap (19).  
If metal filings are detected, locate cause and rectify.  
Contact the **Terex O&K Service**, if required.
- Replace also the return-flow filter in the filter housing (cooling-system).  
The return-flow filters are located under the caps (30, Fig. 3-43:).  
(Cf. under "Hydraulic oil return-flow filter / Filter housing (cooling-system)").

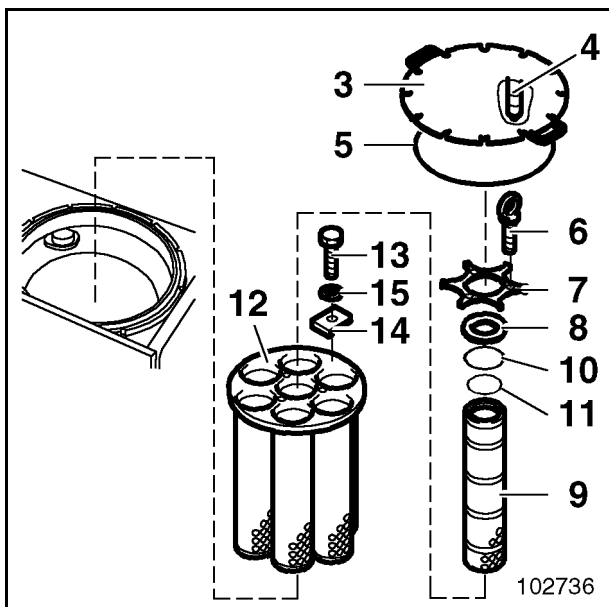

Fig. 3-42:

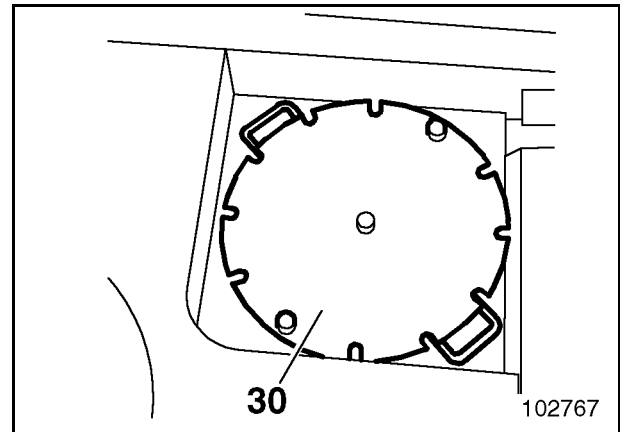

Fig. 3-43:

## Changing the hydraulic oil



**Read and observe the "Inspection and servicing - Safety instructions" chapter.**

Switch off the electric motors.

Risk of scalding caused by hot hydraulic oil.

The hydraulic oil reservoir itself may also be hot.

Avoid skin contact.

Skin contact with hydraulic oil may cause skin injury.

Wear protective gloves and firm working clothing.

Collect escaping oil and discard without polluting the environment.



**Do not start up the electric motors when the hydraulic oil reservoir is empty. The hydraulic pumps may be destroyed if they are allowed to run dry.**

## Drawing off hydraulic oil

The hydraulic oil can also be drawn off through the service station (Fig. 3-58):

- Bring hydraulic oil to operating temperature (ca. 50° C / 122°F).
- Retract hydraulic cylinders as far as possible and stand working equipment on the ground.
- Switch off the electric motors.
- Unscrew cap of express coupling (10).
- Connect hose line of the service vehicle.

The hose line and its use are described in the "Hose line for oil change" section.

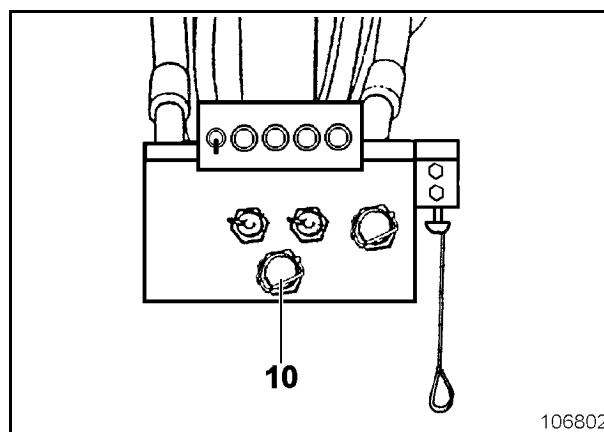

Fig. 3-58:

- Remove hose line. The coupling closes automatically.
- Screw on protective cap.

## Gearbox venting

The gearbox is vented through the breather valve (2, Fig. 3-75:).

Clean breather valve (2) in accordance with servicing plan.

- Unscrew breather filter (2), clean with white spirit or paraffin oil and blow dry with compressed air.
- Screw breather filter (2) back in place.

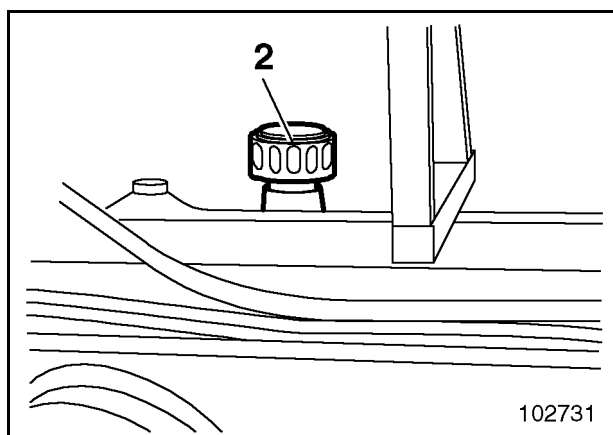

Fig. 3-75:

## Pre-chambers, checking oil level

Oil level in the pre-chambers is visible in the inspection glass (3, Fig. 3-76:) of the expansion reservoir (1).

The oil level must be checked regularly.

Oil level must be at middle of the inspection glass (3). Top up with oil if necessary.

The pre-chambers are vented through the breather filter (2).

Clean breather filter according to the inspection plan.

- Unscrew breather filter (2), clean in white spirit or paraffin oil and blow dry with compressed air.
- Screw breather filter (2) back in place.

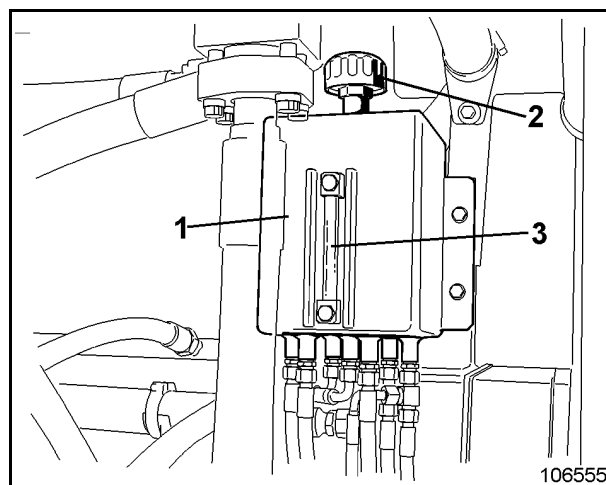

Fig. 3-76:

## SLEWING RING



Read and observe: "Inspection and servicing - Safety instructions."

Switch off electric motors.  
Wear protective gloves and firm protective clothing.

### Slewing ring - Instructions

The grease filling must be replaced:

- when repairs have been carried out on the slewing ring, the slewing ring seals or the slewing ring housing.

Remove old grease completely before filling in new grease.

If greater losses are detected, locate cause immediately to prevent damage to the slewing ring. Greases and greasy cleaning rags must not be allowed to pollute the environment. Discard grease and greasy cleaning rags separately from other waste without polluting the environment.

### Bearing races

The **central lubricating system** supplies grease continuously to the two **roller bearing races** and the **internal gearing**.

The grease is pumped to the greasing points of the bearing races by a distributor (Fig. 3-92:).

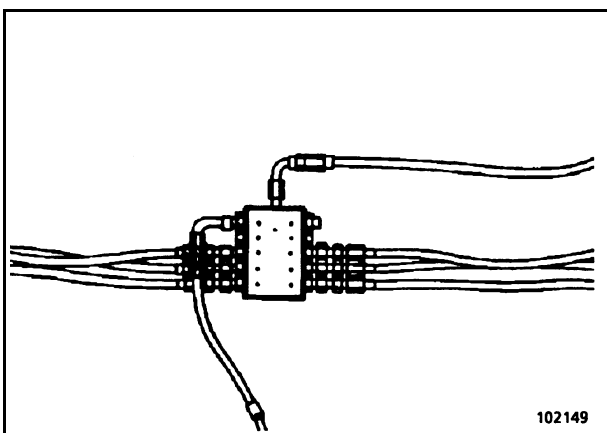

Fig. 3-92:

### Internal gearing

The internal gearing (1, Fig. 3-93:) and the pinion (2) are enclosed in a housing (3, Fig. 3-94:). The housing forms a grease-filled trough in which the pinion of the slewing mechanism moves.

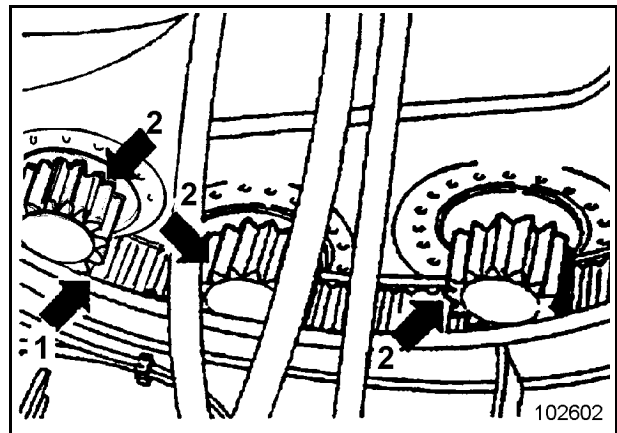

Fig. 3-93:

The grease is pumped to the greasing port of the grease trough by the distributor (Fig. 3-92:). The amount of grease used up during operation is replenished by the central lubricating system.

The housings have a check opening which is closed with a cover (2, Fig. 3-94:). For checking, the cover must be removed.

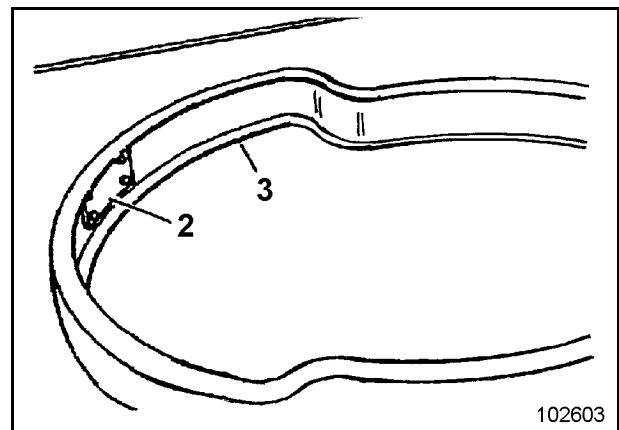

Fig. 3-94:

## LADDER (OPTIONAL)

To allow the ladder (Fig. 3-113:) to be lowered with the electric motors at standstill as well as in an emergency, the ladder mechanism is equipped with a pressure accumulator (1, Fig. 3-114:).

The pressure accumulator (1) is located in the superstructure and is accessible from the ground.

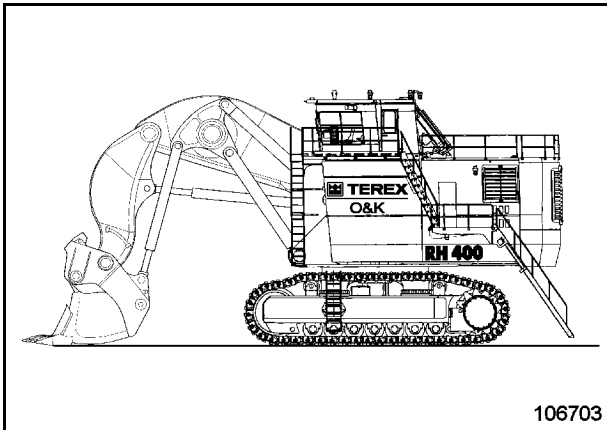

Fig. 3-113:

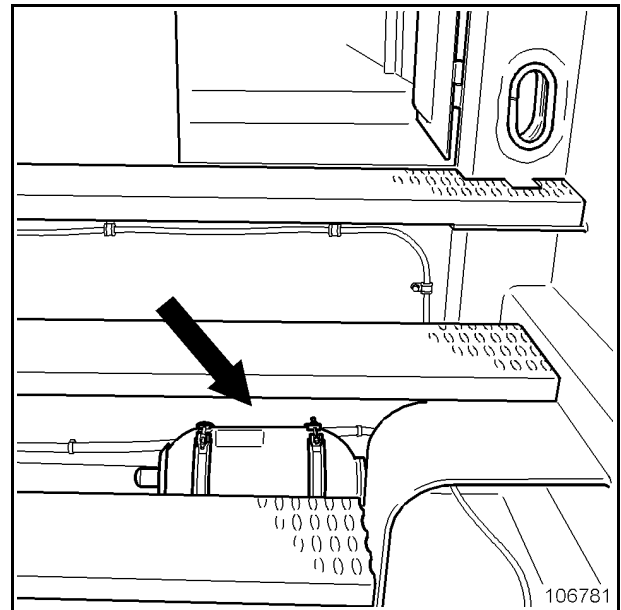

Fig. 3-114:

## 4 REPAIR WORK

	Operating instructions	Target group
<b>Part 1</b>	<b>INTRODUCTION FUNDAMENTAL SAFETY INSTRUCTIONS</b>	<b>Operating personnel</b> + <b>Inspection and servicing personnel</b> + <b>Repair personnel</b>
<b>Part 2</b>	<b>OPERATION</b>	<b>Operating personnel</b>  The operating personnel must have know-how relevant to the operation and the application of this or comparable machines.
<b>Part 3</b>	<b>INSPECTION AND SERVICING</b>	<b>Inspection and servicing personnel</b>  The inspection and servicing personnel must have know-how relevant to the inspection and servicing of this or comparable machines.
<b>Part 4</b>	<b>REPAIR WORK</b>	<b>Repair personnel</b>  The repair personnel must have know-how and experience relevant to the repair of this or comparable machines.
<b>Part 5</b>	<b>ANNEX</b>	<b>Operating personnel</b> + <b>Inspection and servicing personnel</b> + <b>Repair personnel</b>
<b>Part 6</b>	<b>INDEX</b>	<b>Operating personnel</b> + <b>Inspection and servicing personnel</b> + <b>Repair personnel</b>



**NOTES**

A series of horizontal dotted lines providing space for handwritten notes.

## ABBREVIATIONS

<b>A</b>	Ampere (SI base unit of electric current)
abt.	about
acc.	according to
Ah	Ampere hours (SI base unit of quantity of electricity)
API	American Petroleum Institute
approx.	approximately
<b>BA</b>	= OI = Operating instructions
bar	unit of pressure, 1 bar = 14.5 psi
Bh	= OH = Operating hour
<b>CE</b>	Communauté Européenne = European community
CECE	Committee for european Construction Equipment (Defines a measure for bucket, grab or scoop filling)
CEN	European Standardization Committee
cm	centimeter (= $\frac{1}{100}$ m)
cm <sup>3</sup> /rev	Cubic centimeters per revolution
CCW	counterclockwise
CW	clockwise
<b>dB(A)</b>	Decibel (sound intensity according to measuring method A)
dia.	Diameter
DIN	German Industrial Standard
<b>EDS</b>	Electronic diagnostic system
eff.	effective
e.g.	for example
etc.	etcetera
<b>Fig.</b>	Figure, serial number of illustration
FOPS	Falling objects protective structures
FS	Rock shovel (working equipment)
ft	foot (unit of distance), 1 ft = 0.30 meter
<b>gal</b>	gallon (unit of volume), 1 gal = 3.78 liters
GLR	Full-load controller (electronic module for PMS)
<b>HD</b>	Heavy duty
Hydr.	Hydraulic, Hydraulics
<b>i</b>	Transmission ratio
i.e.	id est = that is
IFN	ISO service rating, blocked

Incl.	including, inclusive of
ISO	International Standardization Organization
<b>kg</b>	Kilogram (unit of weight), 1 kg = 2.2 lb
kg/dm <sup>3</sup>	Kilograms per cubic decimeter (= unit of specific density)
km/h	Kilometers per hour
kNm	KiloNewtons per meter (1 kNm = 1000 Nm) = unit of torque
kW	Kilowatt (1 kW = 1.36 hp)
<b>l</b>	Liter (unit of volume), 1 liter = 0.26 gal
lb	pound (unit of mass), 1 lb = 0.45 kg
Lb/in <sup>2</sup>	Pounds per square inch (= psi)
LC	Long crawler
LDA	Charge pressure-dependent full-load limiter
LED	Light-emitting diode
l/min	Liters per minute
LpA	Sound pressure at workplace
LS	Limited slip
LwA	Sound power level of the machine in stationary operation
<b>m</b>	Meter (unit of distance), 1 m = 3.28 ft
M <sub>A</sub>	Tightening torque
mA	Milliampere (= $\frac{1}{1000}$ A)
max.	maximal, maximum
min.	minimal, minimum
min <sup>-1</sup>	Revolutions per minute
mm	Millimeter (= $\frac{1}{1000}$ m)
<b>N</b>	Normal, standard version
N, kN	Newton, kiloNewton (unit of force)
NLGI	National Lubricating Grease Institute (USA)
NLGI--Klasse	Consistency - lubricant classification acc. to DIN 51 818
Nm	Newtonmeter (unit of torque)
No.	Number
<b>OH</b>	Operating hour
op.inst.	Operating instructions
OW	Superstructure
oz	ounce (unit of volume) 1 oz = 0.03 liter

CLICK HERE TO **DOWNLOAD** THE COMPLETE MANUAL

- Thank you very much for reading the preview of the manual.
- You can download the complete manual from: [www.heydownloads.com](http://www.heydownloads.com) by clicking the link below



- Please note: If there is no response to CLICKING the link, please download this PDF first and then click on it.

CLICK HERE TO **DOWNLOAD** THE COMPLETE MANUAL