



BI015809
October 2014



Operation and Maintenance Manual

6090FS

Hydraulic Shovel

No. DHS90009, DHS90010



CLICK HERE TO **DOWNLOAD** THE COMPLETE MANUAL

- Thank you very much for reading the preview of the manual.
- You can download the complete manual from: www.heydownloads.com by clicking the link below



- Please note: If there is no response to CLICKING the link, please download this PDF first and then click on it.

CLICK HERE TO **DOWNLOAD** THE COMPLETE MANUAL



OPERATING INSTRUCTIONS RH400

Table of contents

CENTRAL LUBRICATING _____	3-109
Design _____	3-109
Function _____	3-110
Filling up the grease container _____	3-111
Breather filter _____	3-111
Checking the greasing pressure _____	3-112
Unblocking a grease line _____	3-112
Oilfilter for hydraulic circuit grease pump replace _____	3-113
Grease filter replace (Filling the grease container) _____	3-114
Grease filter replace (Grease lines) _____	3-115
OTHER MAINTENANCE _____	3-116
Engine _____	3-116
Equipment _____	3-117
LADDERS (OPTIONAL) _____	3-118
Pressure-accumulator inspection regulations _____	3-119
Extract from the German regulations _____	3-119
Checking the gas charging pressure in the pressure accumulator _____	3-119
ON-BOARD CRANE (OPTIONAL) _____	3-120
Monitoring, warning and control elements _____	3-120
Checking the on-board crane _____	3-120
Drive unit _____	3-121
On-board crane _____	3-121
PUTTING THE EXCAVATOR OUT OF OPERATION AND RECOMMISSIONING _____	3-122
Putting the excavator out of operation _____	3-122
Battery storage _____	3-122
Recommissioning _____	3-122
NOTES _____	3-124
4 REPAIR WORK _____	4-1
REPAIR WORK - SAFETY INSTRUCTIONS _____	4-3
REPAIR WORK, FIRE AND EXPLOSION HAZARD _____	4-5
ENGINE _____	4-6
ELECTRICAL SYSTEM _____	4-7
Assisted starting (with jumper cables) – Safety instructions _____	4-7
Assisted starting (with jumper cables) _____	4-7
Starting the engine with jumper cables (external batteries) _____	4-7
HYDRAULIC SYSTEM _____	4-9
Repair instructions _____	4-9
Hydraulic hoses – Instructions _____	4-9



Special work in conjunction with utilization of the machine and maintenance and repairs as well as troubleshooting during work; disposal of parts and consumables

Observe the adjusting, maintenance and inspection activities and intervals set out in the operating instructions, including information on the replacement of parts and equipment. These activities may be executed by skilled personnel only.

Brief operating personnel before beginning special operations and maintenance work, and appoint a person to supervise the activities.

In any work concerning the operation, conversion or adjustment of the machine and its safety-oriented devices or any work related to maintenance, inspection and repair, always observe the start-up and shut-down procedures set out in the operating instructions and the information on maintenance work.

Ensure that the maintenance area is adequately secured.

If the machine is completely shut down for maintenance and repair work, it must be secured against inadvertent starting by:

- ➔ removing the ignition key and
- ➔ attaching a warning sign.

Carry out maintenance and repair work only if the machine is positioned on stable and level ground and has been secured against inadvertent movements.

To avoid the risk of accidents, individual parts and large assemblies being moved for replacement purposes should be carefully attached to lifting tackle and secured. Use only suitable and technically perfect lifting gear and suspension systems with adequate lifting capacity. Never work or stand under suspended loads.

The fastening of loads and the instructing of crane operators should be entrusted to experienced persons only. The marshaller giving the instructions must be within sight or sound of the operator.

For carrying out overhead assembly work always use specially designed or otherwise safety-oriented ladders and working platforms. Never use machine parts as a climbing aid

Wear a safety harness when carrying out maintenance work at heights above 1 m.

Wear an approved harness equipped with fall arresters and safety lines.

Keep all handles, steps, handrails, platforms, landings and ladders free from dirt, snow and ice.

Clean the machine, especially connections and threaded unions, of any traces of oil, fuel or preservatives before carrying out maintenance/repair. Never use aggressive detergents. Use lint-free cleaning rags.

Before cleaning the machine with water, steam jet (high-pressure cleaning) or detergents, cover or tape up all openings which - for safety and functional reasons - must be protected against water, steam or detergent penetration. Special care must be taken with electric motors and switch-gear cabinets.

Ensure during cleaning of the machine that the temperature sensors of the fire-warning and fire-fighting systems do not come into contact with hot cleaning agents as this might activate the fire-fighting system.

After cleaning remove all covers and tapes applied for that purpose.

After cleaning, examine all fuel, lubricant, brake and hydraulic fluid lines for leaks, loose connections, chafe marks and damage. Any defect found must be rectified without delay.

Always tighten any screwed connections that have been loosened during maintenance and repair.

Any safety devices removed for set-up, maintenance or repair purposes must be refitted and checked immediately upon completion of maintenance and repair work.

Ensure that all consumables and replaced parts are disposed of safely and with minimum environmental impact.



OPERATION, FIRE AND EXPLOSION HAZARD



Safety instructions

Prior to commencing work, obtain information on the national and corporate rules for the prevention of accidents and avoiding fires.

Pay particular attention to hazards caused by combustible and easily flammable substances.

Obtain information on the safe handling of the fire extinguishers to be used.

Avoid smoking and open fire on, next to and below the excavator.

Combustible and easily or highly inflammable substances or liquids increase the risk of fire and explosion

Do not store or transport flammable substances on the excavator during the work. This is also valid for pressure vessels containing flammable substances as, for instance, spray oil or cold-starting fluid (ether). They are heat-sensitive and can explode even if exposed only to intensive sunlight.

Clean the excavator carefully, if oil, grease, fuel, detergents or cold-starting fluid have been spilled over the machine. If possible, use a steam-jet cleaner for cleaning.

These substance can also ignite themselves if they come close to hot units or objects as, for instance, a turbocharger.

Clean rubber or electrical with compressed air only.

Ensure sufficient ventilation.

Even battery gases can ignite in open flames or fire.

Avoid parking the excavator in places where

- combustible substances such as coal dust or tar are present.
- open or smouldering fire may occur.

Remove the excavator from such an area where combustible or easily flammable liquids have spilled from the excavator onto the ground.

Flying sparks (caused by welding, flame cutting, grinding, electrical short-circuit) may cause fire on the ground that can spread to the excavator.

Clean the excavator before starting work.

Place suitable fire guardings (fire barriers) if open fire or flying sparks cannot be avoided during repair work.

If necessary, also cover the ground with fire-protective blankets.

Apply special protection to cables, cable ducts as well as to hose and pipe lines.

The engine compartment can be equipped with pressure vessels containing cold-starting fluid (ether). Ether is toxic and highly flammable; the vessels are under pressure. These pressure vessels can explode if exposed to high temperatures (above 49°C / 120°F) or in the event of damage. Protect the pressure vessels against damage before beginning to work in or close to the engine compartment.

Ensure sufficient ventilation.

Do not keep any fire extinguishers that are not suitable or have not been tested.

Do not extinguish flammable liquids with water. Use:

- dry-powder, carbon-dioxide or foam extinguishing compounds.

When getting into contact with burning substances, the fire-fighting water would abruptly evaporate and distribute the substance such as oil over a wide area. Water causes short-circuits in the electrical system thus possibly entailing new hazards.

Call the fire brigade.

Have all your welding, flame cutting and grinding work approved before starting work.

Cab interior lamps

The interior lamps are switched on and off with switch (2, Fig. 2-15:).

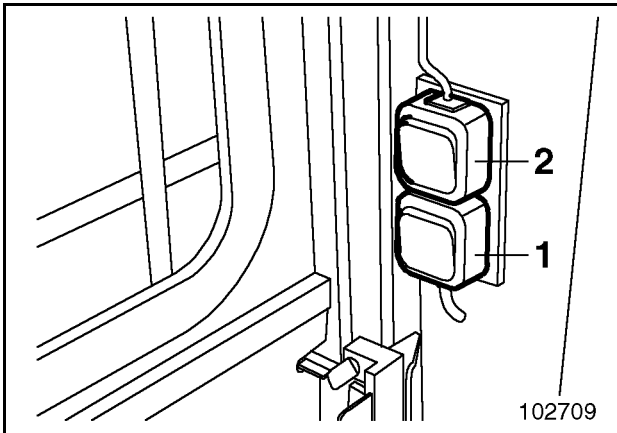

Fig. 2-15:

The interior lamps can be used even if the electrical system is switched off.

Therefore, switch off the interior lamps when leaving the machine. The batteries may be discharged if the interior lamp is left on for prolonged periods.

The interior lamps are also switched on and off with switches (1, Fig. 2-16:) or (96, Fig. 2-17:).

Switch position 0 - lamp off

1 - lamp on.

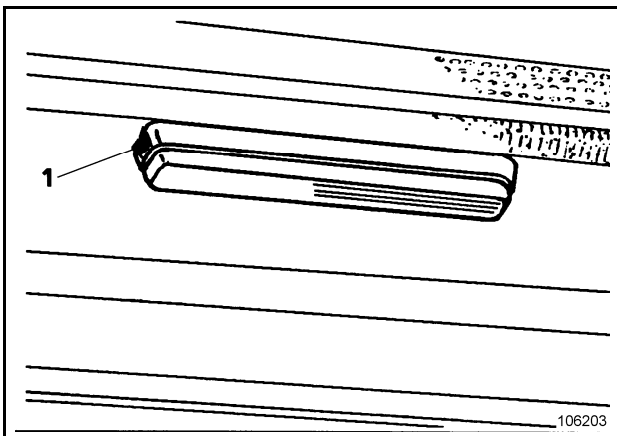

Fig. 2-16:

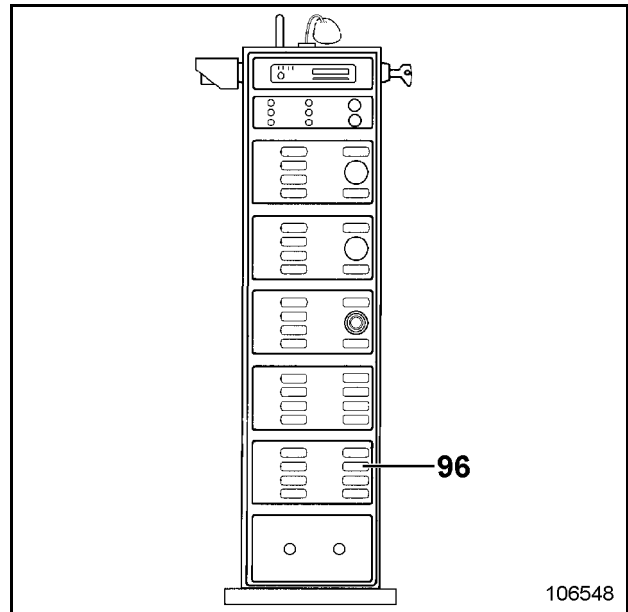

Fig. 2-17:

Control column lighting

The control column front could be illuminated with lamp (30, Fig. 2-18:). Turn lamp head from "0" to "I" to switch the lamp on.

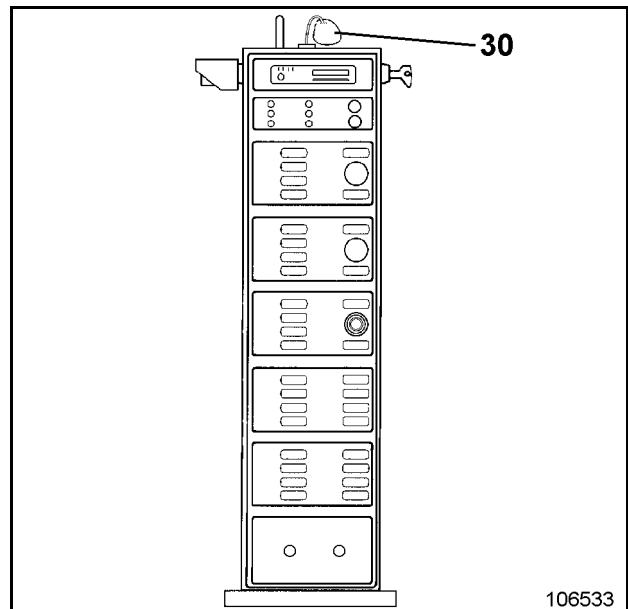

Fig. 2-18:



(Fig. 2-40:)











No.	Element	Function	Symbol
1	BCS Electronic measuring-data collection and processing system	Collection of essential operating data of the excavator	
2	Monitor BCS	Displays the data collected. Gives warnings and provides help, if desired.	
3	UP button	Selects the BCS program Positions the Cursor	
4	DOWN button	Selects the BCS program Positions the Cursor	
5	ENTER button	Confirms a program Activates a desired program	
6	BACK button	Recalls the Service Menu	
7	HOLD button	Freezes actual service data	
8	Print button	Recalls the Print Menu	
9	SERV. button	Recalls the Service Menu	
10	HELP button	Recalls the Help Menu	
11	BL + button	Adjusts BCS monitor background lighting	
12	BL - button	Adjusts BCS monitor background lighting	

Fig. 2-45:











No.	Element	Function	Symbol
61	Switch Starting (right engine 2)	Starts the engine. Hold switch approx. 5 – 7 sec. This is necessary to start and pressurize the engines prelube system. After then the engine starts automatically.	
62	Switch Stopping (right engine 2)	Shuts off the engine	
63	Switch Idling (right engine 2)	Shuts off the engine with 5 minutes after run.	
64	Switch	Not connected	
65	Switch Diagnostic ON / OFF	Switches fault codes monitoring via warning lamps Pos. 44 - 46 on / off.	
66	Speed adjustment Potentiometer (right engine 2)	Regulates the engine speed <ul style="list-style-type: none"> ▪ turn CCW to limit stop: idling speed ▪ turn CW to limit stop: full-load speed 	
67	Switch Diagnostic incre- ment / decrement	Switches between fault codes monitored via Pos. 44 - 46.	

Fig. 2-50: (Engine 1 (left) monitoring)

No.	Element	Function	Symbol
121	Antenna (optional)		
122	Radio (optional)		
123	Monitoring lamp Oil interval prolonging (left engine 1, optional)	Lamp is lit up, when one oil pump is running. Lamp flashes or pulsates, when both oil pumps are running.	
124	Monitoring lamp Oil interval prolonging (right engine 2, optional)	Lamp is lit up, when one oil pump is running. Lamp flashes or pulsates, when both oil pumps are running.	
131	Monitoring device Engine monitoring (engine 1 left)	Indicates different parameters on the display (E) Use push buttons (C and D) to scroll through parameter list. Indicator lamps (A and B) lit when an active fault occurs.	
132	Thermometer Engine temperature (engine 1 left)	Indicates the cooling-water temperature.	
133	Pressure gauge Engine oil pressure (engine 1 left)	Indicates the oil pressure in the diesel engine lubricating system.	
134	Warning device Engine monitoring (engine 1 left)	Gives an acoustic warning signal if a fault is reported <ul style="list-style-type: none"> Engine oil pressure too low, Engine temperature too high.  <p>Lower the equipment to the ground and shut off engine immediately if the warning device (134) sounds. The warning device (134) continues to sound until the fault has been rectified.</p>	
135	Indicator lamp Idle (engine 1 left)	Lits up when engine is in idle phase.	
136	Warning lamp Cooling water level (engine 1 left)	Lits up when the cooling-water level is too low.	
137	Warning lamp Alternator (engine 1 left)	Lits up when the batteries are not recharged.	

Assemblies resp. reservoirs	Measuring device	Remarks
Fuel tank	BCS fuel indicator (2, Fig. 2-58:)	<p>BCS displays the fuel level in the fuel tanks.</p> <p>Stop filling when the fuel tanks are full (service station shuts off automatically by counter-pressure).</p> <p>Maximum fuel level can also be monitored by the indicator lamps (32 and 33, Fig. 2-59:), to do so:</p> <p>Switch on the display system with toggle switch (23), indicator lamp (22) lits up.</p> <p>Start filling in fuel via expresscoupling (1).</p> <p>When the right fuel tank is filled, indicator lamp (33) lits up. When the left fuel tank is filled, indicator lamp (32) lits up.</p> <p>After filling the fuel tanks, switch off the display system with toggle switch (23), indicator lamp (22) is off.</p>

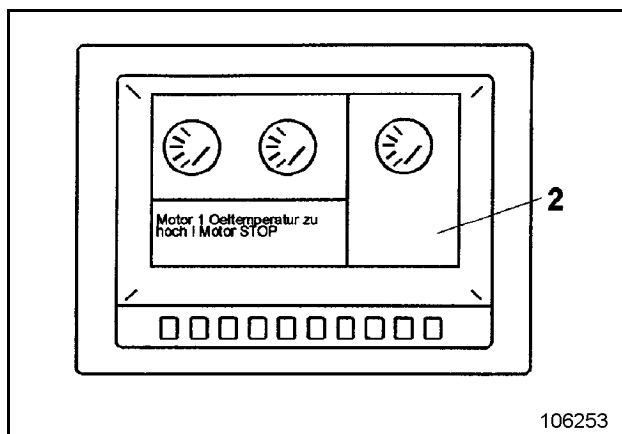

Fig. 2-58:

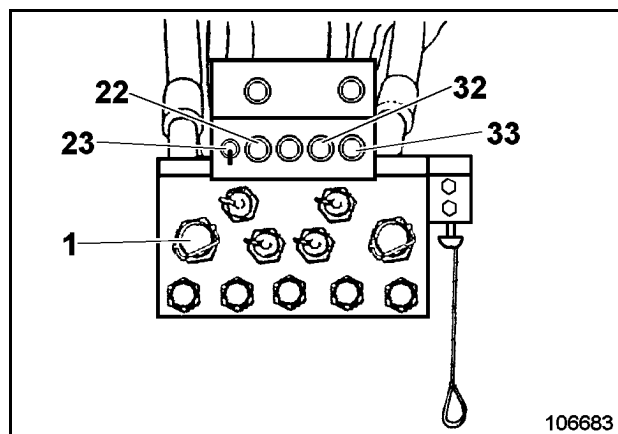

Fig. 2-59:

TRAVELLING SAFETY INSTRUCTIONS

Have the attachment raised only so far as to permit the machine to be driven under overhead power lines without any risk.

Close the cab door.

If the machine is fitted with a safety belt for the operator, fasten the belt.

If the superstructure is turned by more than 90° from the BASIC POSITION, the excavator travels in the opposite direction to that selected.

If the position of the superstructure in relation to the undercarriage is not exactly known, touch the accelerator lightly to see which direction the machine takes, before initiating the full travelling movement.

Warn persons in the immediate vicinity by sounding the horn before setting off.

Never drive across slopes.

Take the utmost care on slippery, greasy ground.

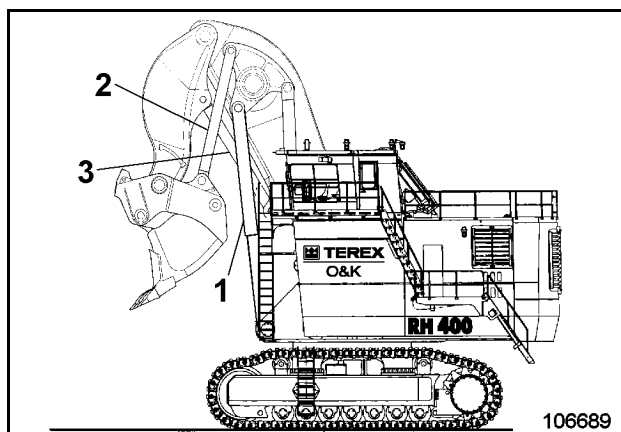

Fig. 2-85:

Running-in specifications for components of the crawler tracks:

Prior to initial commissioning and/or after repair work, run in the idlers, track rollers and support rollers as follow:

- Raise the equipment (Fig. 2-85:).
- Drive the excavator in reverse approx. 50 m / 164ft.
- Drive the excavator in forwards approx. 50 m / 164ft.
- Stop the excavator.
- Measure the temperature at each idler, track roller and support roller with an infrared thermometer. (at a temperature of approx. 100° C / 212°F wait for idlers, track rollers and support rollers to cool down).
- Repeat this running-in procedure up to 10x.
- Check all idlers, track rollers and support rollers for leaks.

The engines must be at operating temperature before being subjected to full load.

If the machine is to be driven a longer distance, the superstructure must be secured against turning by means of the superstructure holding brake.

Emergency lowering of the equipment

In case of a failing out of the electronic excavator control and / or the engines lower the equipment as follows:

- Switch on the electric system with switch (32, Fig. 2-101:),
- Operate switch (91),
- Push control lever (116) forwards.

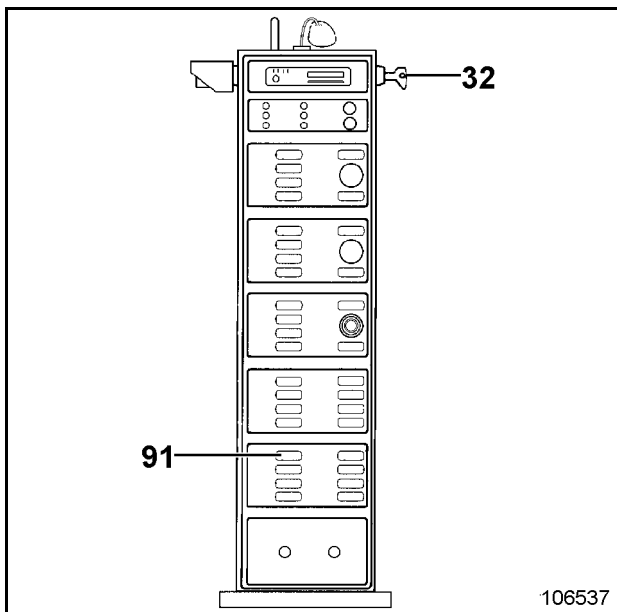

Fig. 2-101:



INSPECTION AND SERVICING - SAFETY INSTRUCTIONS

Operating manual

No inspection and servicing work must be carried out until the operating manual has been read and understood.

Pay special attention to:

Fundamental safety instructions" and all warnings and safety instructions attached to the machine.

The operating manual lists all jobs to be done. The descriptions of job sequences, however, provide only

Experienced personnel with the necessary instructions.

The operating manual must be kept with the machine at all times.

Inspection and servicing personnel

Inspection and servicing personnel must have the necessary know-how on the inspection and servicing of this or comparable machines.

The necessary know-how can be acquired in a several day's instruction, e.g. by an **Bucyrus HEX** mechanic or by attending an **Bucyrus HEX** training course.

Personal protective equipment and working clothing

Wear closely fitting working clothing when working on the machine. Loose, wide garments may catch on machine parts and result in injury.

Wear a safety helmet, safety footwear, gloves and, in the event of high noise levels, ear protectors.

Securing the working equipment

Stand working equipment on the ground in such a way that no movements can be made if mechanical or hydraulic connections become detached.

Secure any equipment or component which is to be mounted or dismantled, or whose position is to be changed, with hoists or appropriate slinging / supporting devices to prevent them from moving, slipping or falling inadvertently.

Securing the machine

Carry out servicing work only if the machine is secured as described in the section "Securing the machine".

Climbing onto and off the machine

Use only the ladders, steps, platforms and handrails provided when climbing onto or off the machine.

Always keep ladders, steps, platforms and handrails in a non-slip, safe state and remove any oil, grease, soil, clay, snow, ice and other foreign matter immediately.

Always face the machine when climbing on and off.

Checking the state of tools

Use only fully functional, reliable tools.

Select the right tool for the job.

Wrenches of the wrong size, for example, may slip and cause injury.



Plan V

Plan V - Once prior to initial commissioning

Page 1 of 2

Location	Servicing work	Quantity/ No.
Engine	Check oil level	2
Engine oil reservoir	Check oil level	2
Cooling system		
Cooling liquid level	Check	2
Electrical system		
Battery	Check liquid level (not applicable when maintenance-free batteries build in)	8
Lighting	Check operation	
Monitoring, warning and control elements	Check function of monitoring, warning and control elements	
BCS	Check emergency OFF function	
	Check function	
Hydraulic system	Check function of working and travelling movement	
Hydraulic oil reservoir	Check pressure (see Technical Handbook)	
Hydraulic cylinders	Check oil level	1
	Vent (see chapter "Venting hydraulic system")	
Pump transfer gearbox	Check oil level	2
- Pre-chambers		
- Expansion reservoir	Check oil level	2
Swing gearbox	Check oil level	6
Travel gearbox	Check oil level	2
- Pre-chambers	Check oil level	2 x 2
- Brake chambers	Check oil level	2 x 2
Swing ring		
Internal gearing	Check grease filling	1
Undercarriage		
Track roller	Check for leaks and free movement	2 x 7
	Check grease filling, fill with grease ³	
Support roller	Check for leaks and free movement	2 x 2
	Check grease filling, fill with grease ³	
Track tensioner	Check pressure	2
Idler	Check for leaks and free movement	2

³ Machines with undercarriage greasing system

CLICK HERE TO **DOWNLOAD** THE COMPLETE MANUAL

- Thank you very much for reading the preview of the manual.
- You can download the complete manual from: www.heydownloads.com by clicking the link below



- Please note: If there is no response to CLICKING the link, please download this PDF first and then click on it.

CLICK HERE TO **DOWNLOAD** THE COMPLETE MANUAL



Plan **A** - after every 250 OH
(at 250, 750, 1250 ... OH)

Plan **B** - after every 500 OH
(at 500, 1500, 2500 ... OH)

Plan **C** - after every 1000 OH
(at 1000, 2000, 3000, 4000 ... OH)

Plan **D** - after every 5000 OH
(at 5000, 15000, 25000 ... OH)

Plan **E** - after every 10000 OH
(at 10000, 20000, 30000, ... OH)

Location	Servicing work	No. of	Plan A	Plan B	Plan C	Plan D	Plan E
Pump transfer gearbox	Carry out oil analysis	2		●	●	●	●
	Change oil	2 ¹³			●	●	●
	- Breather filter	Clean 2 x 1			●	●	●
	- Pre-chamber	Change oil 2 x 9 ¹³			●	●	●
	- Breather filter	Clean 2 x 1			●	●	●
	Oil filter	Check for contamination and damage 2 x 1			●	●	●
	Replace 2 x 1				●	●	
Swing gearbox	Carry out oil analysis	6		●	●	●	●
	Change oil	6 ¹³			●	●	●
Travel gearbox	Carry out oil analysis	2		●	●	●	●
	Check oil level	2		●	●	●	●
	Change oil	2 ¹³				●	●
	- Magnetic rod	Clean 2 x 4			●	●	●
	Pre-chambers	Check oil level 2 x 1		●	●	●	●
		Change oil 2 x 1 ¹³				●	●
	- Magnetic rod	Clean 2 x 1			●	●	●
	Brake chambers	Check oil level 2 x 2		●	●	●	●
		Change oil 2 x 2 ¹³				●	●
	Breather filter	Clean / replace 2 x 3			●	●	●
Swing ring	Check grease filling	1		●	●	●	●
	Gearing / pinion	Check condition		●	●	●	●
	Fastening bolts (swing ring, undercarriage and super-structure)	Check for tightness (see Technical Handbook)				●	●

¹³ see "Refilling quantities – Oil" table



I. Oils for combustion engines and compressors

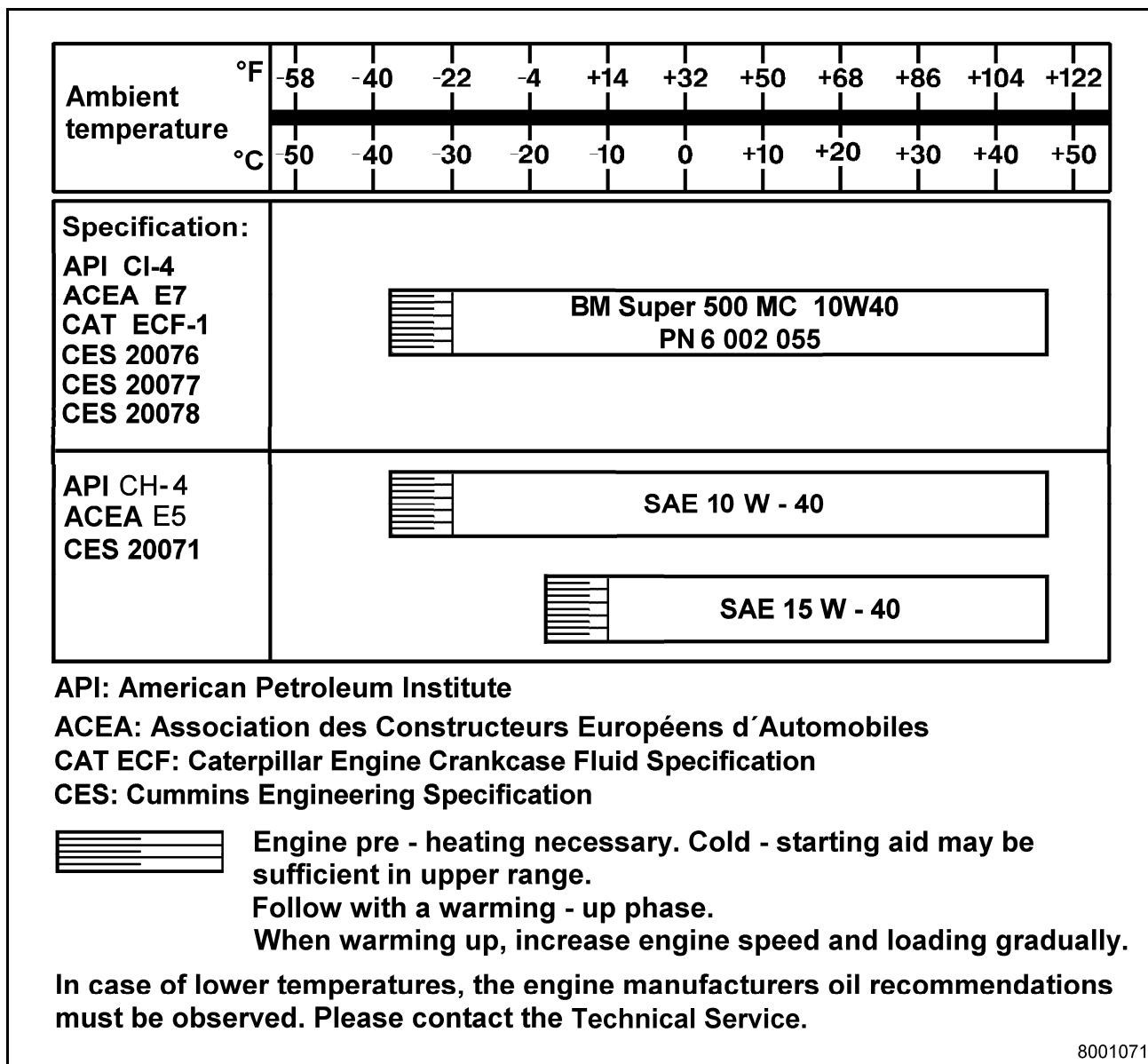

Fig. 3-3:

Changing the engine oil



Risk of scalding from hot engine oil.

The engines may also be hot.

Wear protective gloves and firm working clothing.

Collect escaping oil and discard without polluting the environment.

Drawing off engine oil with the service station.

- Bring engine oil to operating temperature.
- Park the machine on a horizontal surface and secure.
- Shut off the engines.

Draw off the engine oil through

- express coupling (8, Fig. 3-19:) for the lefthand engine
- express coupling (9) for the righthand engine.
- Unscrew cap of express coupling and connect hose line of the service vehicle.

The hose line and its use are described in the "Hose line for oil and cooling liquid change" section.

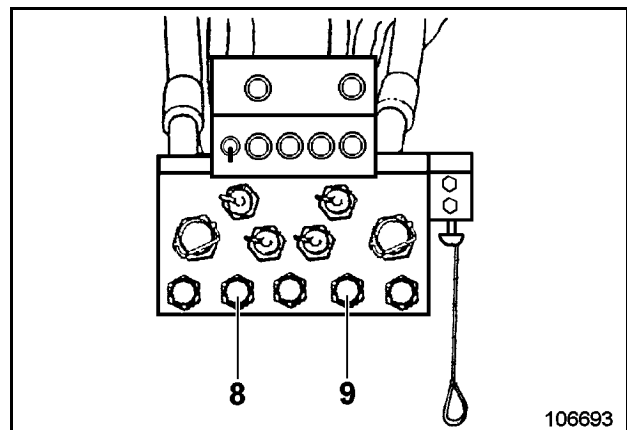

Fig. 3-18:

After the engine oil has been drawn off:

- Remove the hose line. The express coupling closes automatically.
- Screw on protective cap.

Topping up cooling-liquid

Cooling liquid can be topped up through the filler tube of the expansion reservoirs or through the service station (tanklift).



Risk of scalding from hot cooling liquid.

Wait until cooling liquid has cooled down.

Open caps of the expansion reservoirs cautiously.

Do not fill in cold cooling liquid when the engine is at operating temperature.

Before refilling, allow engine to cool down to below 50° C / 122°F.

- Fill cooling liquid through filler tube (1, Fig. 3-35:) into the cooling system.

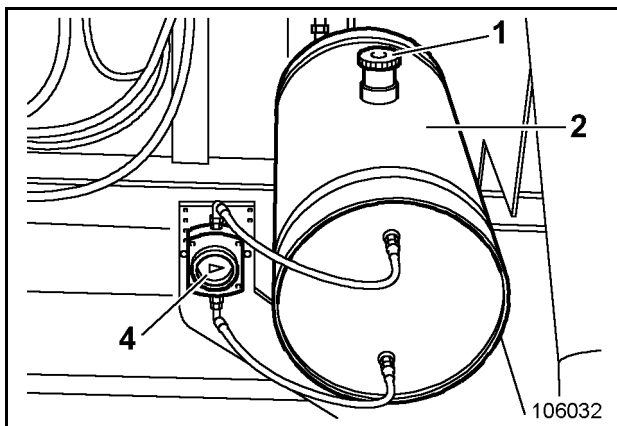

Fig. 3-34:

For topping up of the cooling system use specially prepared water only.

Specially prepared water must consist of:

- calcium-free water, distilled water, rain water,
- anti-freeze compound.



The anti-freeze compound must always be filled into the system independent of climatic conditions.

In this case, it serves as corrosion protection for the aluminium cooler.

The mixing ratio of anti-freeze / cooling water must be at least 50 % : 50 % (anti-freeze protection down to -40 °C / -40°F).

For use at lower temperatures, the amount of anti-freeze must be increased accordingly.

For further detailed information see engine manufacturer's operation and maintenance manual.

- After topping up cooling-liquid screw cap of the filler tube (1) back in place.

After filling in cooling liquid allow the engines to run for short period to eliminate air voids before topping up with cooling liquid to the lower edge of the filler tube.

In case of significant cooling-liquid losses, the whole cooling system must be checked for leaks.

Check regularly:

- all lines for leaks and all hose clamps for tightness.

Checking the SCA concentration



Observe the instructions of the engine manufacturer with regard to the SCA concentration (see engine manufacturer's operation and maintenance manual).

OPERATING INSTRUCTIONS RH400

Inspection and servicing

- Loosen the vent cap (1, Fig. 3-52:) on the filter to be replaced.
- Open the drain valve (5) and drain the fuel. Then close the drain valve (5).

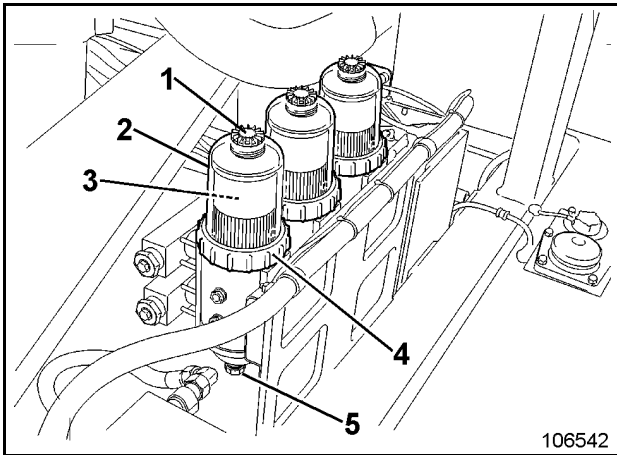

Fig. 3-51:

- Using the collar / vent cap wrench (Fig. 3-53:) remove the clear cover (2, Fig. 3-52:) by removing the collar (4).

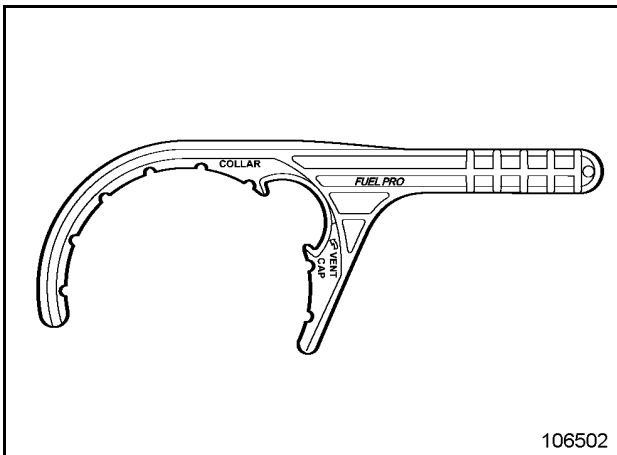

Fig. 3-52:

- Discard the O-ring (8, Fig. 3-54:) from the base of the cover (2).
- Remove the filter element (3) by pulling upwards and twisting slightly from the filter stud. Remove the sealing grommet (7) too.

New O-ring seals and grommet are supplied with the new filter elements.

Dispose of the filter in an environmentally responsible manner according to the state, federal, national and / or global environmental recommendations.

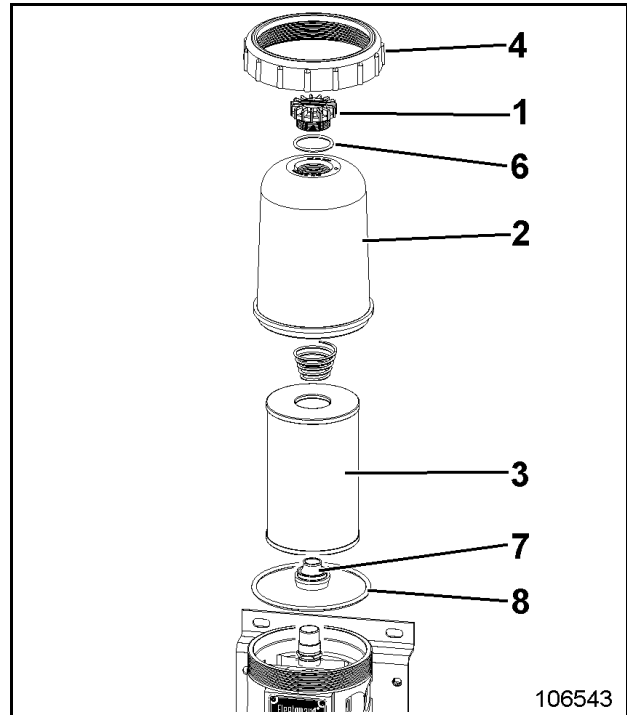

Fig. 3-53:

- Install the new filter (3) and grommet (7) on the filter stud.
- Place the new cover O-ring (8), cover (2) and collar (4) over the filter.
- Press down filter, holding it in place, while hand tightening the the collar until seated. **Do not use tools to tighten.**
- Fill the clear cover (2) with enough fresh, clean fuel to cover the bottom half of the filter element.
- Make shure the new O-ring (6) is installed on the vent cap (1), install the vent cap (1). **Tighten by hand.**
- Swing the valve handle (1, Fig. 3-51:) into position "ON".
- Raise the engine rpm for one minute to purge the air from the system.
- Replace the other outer filter the same way.
- Then replace the center fuel filter (see. "Replacing the center fuel filter").
- After then replace the filters at the other engine.

Checking and cleaning the filter element

Check the filter paper of the element by inserting a lamp into the element (Fig. 3-69:). Any damage can then be seen.

 **Replace damaged or distorted element immediately.**

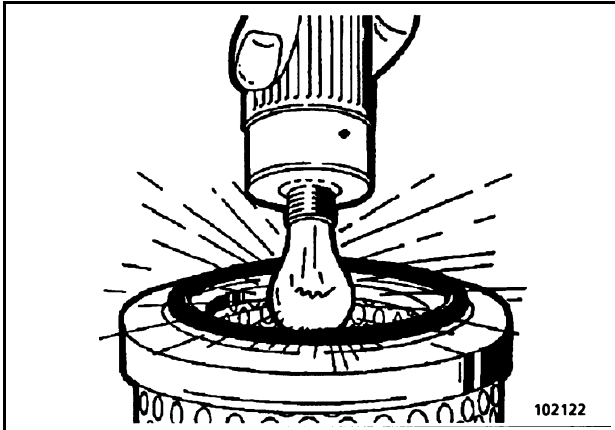

Fig. 3-68:

Check element seal. If damaged, replace filter element too.

Cleaning with compressed air allows the filter element to be re-used immediately.

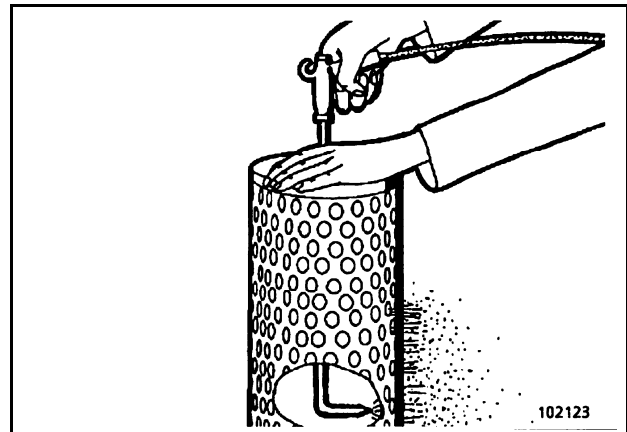

Fig. 3-69:

Blow filter element (Fig. 3-70:) dry with compressed air by moving the compressed-air piston up and down inside it.

The pressure at the nozzle must not exceed 6 bars / 87psi.

Cleaning is completed when no more dust is seen to leave the filter element.

 **Never clean filter element by beating it against hard objects.**

Replace main filter element after 1000 operating hours or 3 cleaning cycles, but not later than after one year of operation.

Filter (control circuit)



Read and observe the "Inspection and servicing - Safety instructions" chapter.

Shut off the engines.

Risk of scalding caused by hot hydraulic oil.

The filter housings may also be hot.

Avoid skin contact.

Skin contact with hydraulic oil may cause skin injury.

Wear protective gloves and firm working clothing.

Replacing the filter element

Change filter element regularly and when the BCS indicates a contamination.

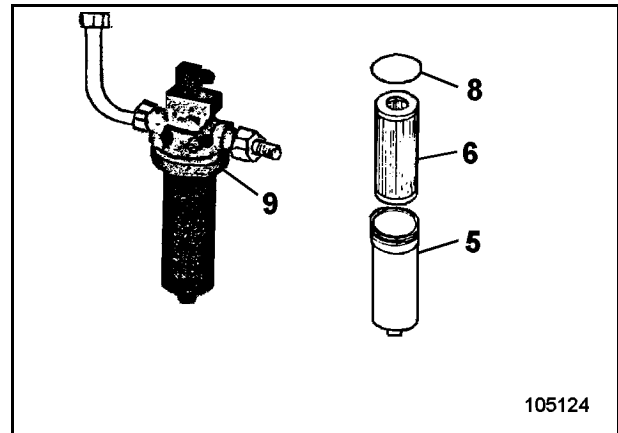

Fig. 3-87:

- Unscrew filter housing (5, Fig. 3-88:).
- Withdraw filter element (6) from filter housing (5).
- Clean filter housing (5) and the sealing face at the filter head (9) with white spirit or paraffin oil.
- Check seals (10 and 14) and replace, if required.
- Insert new filter element into filter housing (5) and refit to the filter head with new, lightly oiled sealing ring (8).
- Check for leaks after putting the filter into operation.

Cleaning the hydraulic oil cooler



Risk of injury from rotating cooler fan blades.

Shut off the engines.

Never start cleaning work until the cooler fan blades have stopped turning.

The hydraulic oil coolers reach the same temperature as the hydraulic oil. Risk of burning.

Allow the hydraulic oil cooler to cool down.

Wear protective gloves and firm protective clothing.

If the machine is used in places with heavily contaminated ambient air, the hydraulic oil coolers must be cleaned more often than specified in the servicing plan.

The speeds of the fan motors (1, Fig. 3-108:) are thermostat-controlled. The fan motors run at maximum speed when the hydraulic oil temperature reaches ca. 60°C / 140°F.

Cleaning

The hydraulic oil coolers are located in the oil cooler module.

Clean the hydraulic oil coolers at regular intervals.

- Shut off the engines.
- Remove any accumulated dirt.
- Clean the fan blades (2).
- Clean the radiators with a jet of water or compressed air from outside to inside.
- Leave hydraulic oil coolers to dry.
- Check the hydraulic motors (1) for free movement.



In winter-time, check that the fans (2) turn freely and that the cooling fins are free from ice and snow.



Fig. 3-107:

Preliminary gearbox - Draining off oil

- Place a collecting recipient for used oil under the preliminary gearbox. Choose the required capacity in accordance with the "Refilling quantities - Oil" table.
- Unscrew plug (5, Fig. 3-126:) and drain off oil completely.
- Clean plug (5) and screw back in place.

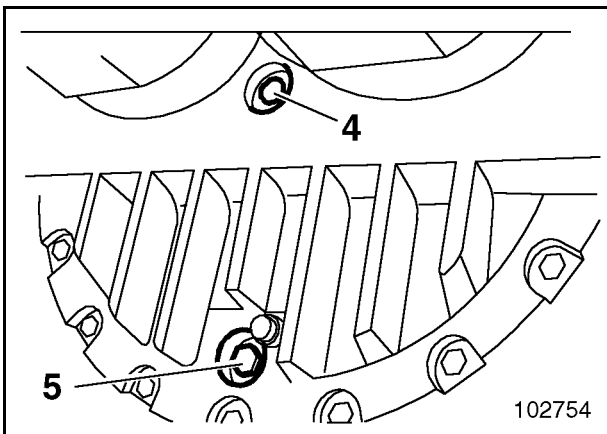

Fig. 3-125:

Main and preliminary gearbox - Filling in oil

- Move the excavator until the screw plugs (1 and 3, Fig. 3-127:) are in the positions shown in the diagram:
- Unscrew plugs (1 and 3). Fill in oil through opening in plug (3) until it flows out of opening in plug (1) or the oil level is visible in the level gauge (4, Fig. 3-126:).

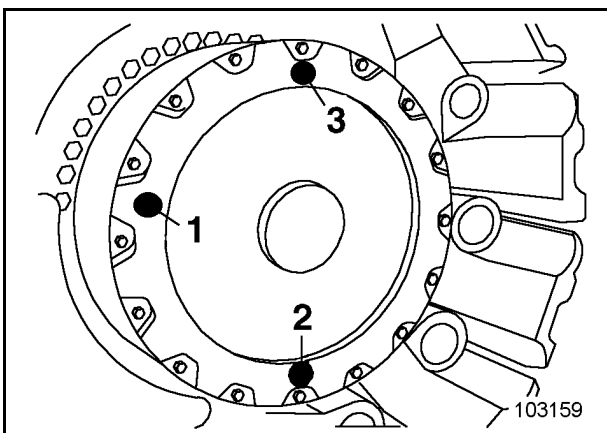

Fig. 3-126:

Pre-chamber - Draining off oil

- Place a collecting recipient for used oil under the pre-chamber. Choose the required capacity in accordance with the "Refilling quantities - Oil" table.
- Unscrew plugs (1, Fig. 3-128:), clean, and screw back into place.

Pre-chamber - Filling in oil

- Unscrew plugs (2, Fig. 3-128:) and overflow (3).
- Fill in oil through the opening of the overflow (3) until it flows out of the opening of the plug (2).

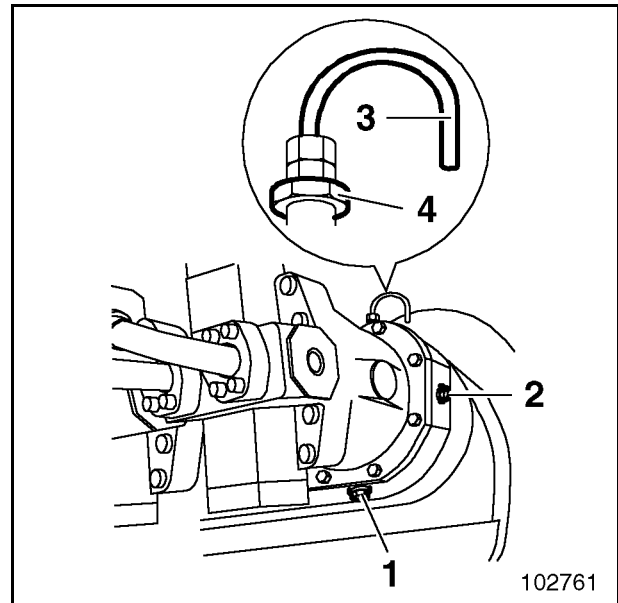

Fig. 3-127:



If oil emerges from the overflow (3, Fig. 3-128:), the external sealing of the driving motor must be checked.

Filling up the grease container

Fill up the grease container through the service station (Fig. 3-142:).

The use of the hose is described in the chapter "Hose for oil and cooling liquid changes"

- Switch on the display system with toggle switch (23, Fig. 3-142:), lamp (22) lights up.
- Unscrew the cap of the express coupling (11).
- Connect the filling hose of the service vehicle.
- Fill in grease.
- When the grease container is full, the monitoring lamp (24) lights up.
- Remove the flexible hose.
The express coupling closes automatically.
- Refit the protective cap.
- Switch off display system with toggle switch (23), lamp (22) is off.

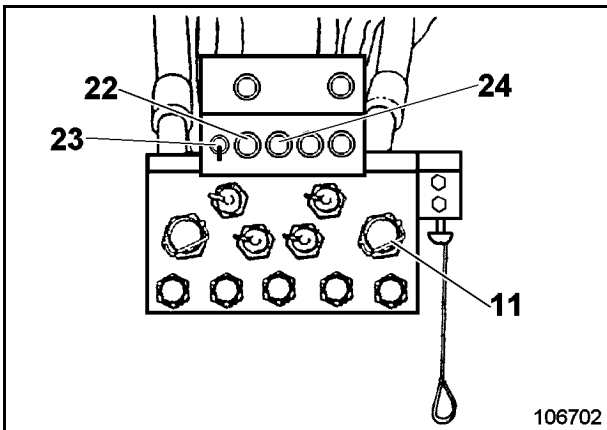

Fig. 3-141:

➤

Breather filter

Check/change the breather filter at regular intervals acc. to the maintenance plans.

- Unscrew wing nut that fixes the cover (10, Fig. 3-143:).
- Withdraw cover (7, Fig. 3-144:) and filter element (8).
- Check filter element. Replace if necessary.
- Re-install breather filter.

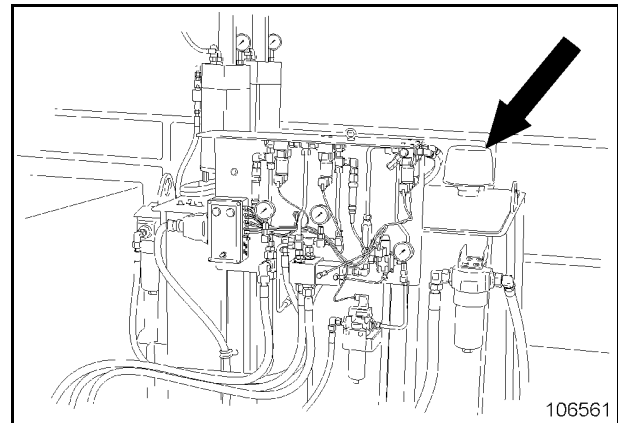

Fig. 3-142:

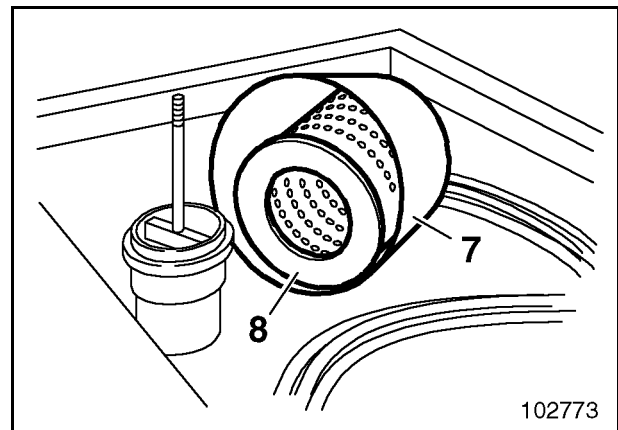

Fig. 3-143:

OPERATING INSTRUCTIONS RH400

Inspection and servicing

Drive unit

The drive unit comprises:

- crane engine
- hydraulic system

Crane engine

See operating instructions for the crane engine.

- Fill up fuel tank through filler (5, Fig. 3-159:) after each deployment.
- Prior to each deployment check the engine oil level with the dipstick; top up if necessary.
- regularly, at least once a year
 - change engine oil
 - replace engine oil filter
 - check / replace air filter
 - replace fuel filter
- Check batteries (7) and cable connections at regular intervals.

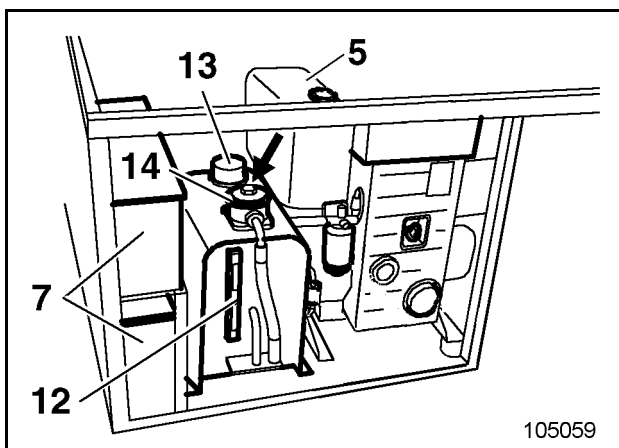

Fig. 3-158:

Air-intake system

Never start up the engine when the air filter is removed.

Hydraulic system

See crane operating instructions.

- Prior to each deployment, check the hydraulic oil level at the inspection glass (12, Fig. 3-159:); top up if necessary.
- Check contamination of hydraulic oil filter regularly at contamination indicator (arrow, Fig. 3-159:).
- Regularly, but at least once a year replace the hydraulic oil filter (14) and the breather filter (13).

On-board crane

Servicing

- Lubricate all bearings regularly and as required, and spray swing ring with a graphite spray (Fig. 3-160:)

1 -	bearing	4 lube points
2 -	joint (column/boom)	2 lube points
3 -	cylinder bearing	5 lube points
4 -	swing ring	

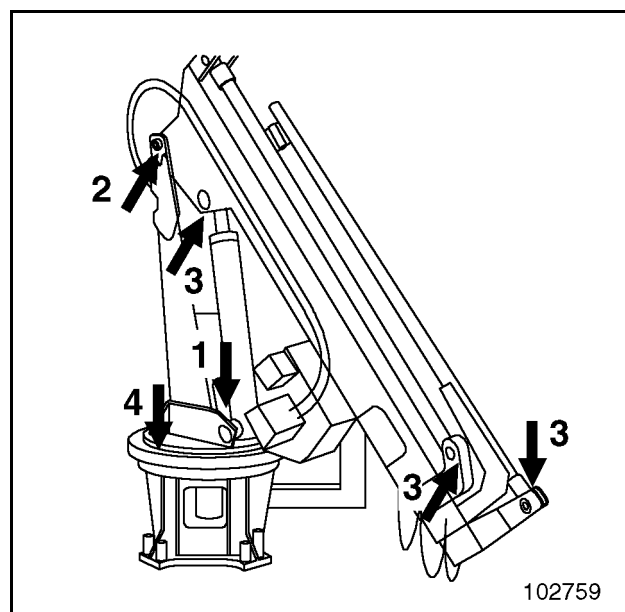

Fig. 3-159:

REPAIR WORK, FIRE AND EXPLOSION HAZARD



Safety instructions

Prior to commencing work, obtain information on the national and corporate rules for the prevention of accidents and avoiding fires.

Pay particular attention to hazards caused by combustible and easily flammable substances.

Obtain information on the safe handling of the fire extinguishers to be used.

Avoid smoking and open fire on, next to and below the excavator.

Even battery gases can ignite in open flames or fire.

Combustible and easily or highly inflammable substances or liquids increase the risk of fire and explosion. This is also valid for pressure vessels containing flammable substances as, for instance, spray oil or cold-starting fluid (ether). They are heat-sensitive and can explode even if exposed only to intensive sunlight.

These substances can also ignite themselves if they come close to hot units or objects as, for instance, a turbocharger.

Do not store these substances on the excavator. If combustible, easily or highly flammable substances or liquids were used during maintenance operations, they must be completely removed from the excavator at the end of the work.

Avoid parking the excavator in places where

- combustible substances such as coal dust or tar are present.
- open or smouldering fire may occur.

Remove the excavator from such an area where combustible or easily flammable liquids have spilled from the excavator onto the ground.

Flying sparks (caused by welding, flame cutting, grinding, electrical short-circuit) may cause fire on the ground that can spread to the excavator.

Place suitable fire guardings (fire barriers) if open fire or flying sparks cannot be avoided during repair work.

If necessary, also cover the ground with fire-protective blankets.

Apply special protection to cables, cable ducts as well as to hose and pipe lines.

Have all your welding, flame cutting and grinding work approved before starting work.

The engine compartment can be equipped with pressure vessels containing cold-starting fluid (ether). Ether is toxic and highly flammable; the vessels are under pressure. These pressure vessels can explode if exposed to high temperatures (above 49°C / 120°F) or in the event of damage. Protect the pressure vessels against damage before beginning to work in or close to the engine compartment.

Ensure sufficient ventilation.

Do not keep any fire extinguishers that are not suitable or have not been tested.

Do not extinguish flammable liquids with water. Use:

- dry-powder, carbon-dioxide or foam extinguishing compounds.

When getting into contact with burning substances, the fire-fighting water would abruptly evaporate and distribute the substance such as oil over a wide area. Water causes short-circuits in the electrical system thus possibly entailing new hazards.

Call the fire brigade.

Clean the excavator carefully after the maintenance, if oil, grease, fuel, detergents or cold-starting fluid have been spilt over the machine. If possible, use a steam-jet cleaner for cleaning.



HYDRAULIC CIRCUIT DIAGRAM

Detailed information can be found in the „Technical Handbook“ chapter 8 or contact **Bucyrus HEX**.

CLICK HERE TO **DOWNLOAD** THE COMPLETE MANUAL

- Thank you very much for reading the preview of the manual.
- You can download the complete manual from: www.heydownloads.com by clicking the link below



- Please note: If there is no response to CLICKING the link, please download this PDF first and then click on it.

CLICK HERE TO **DOWNLOAD** THE COMPLETE MANUAL