

# GROVE GMK5150L

## Operating manual

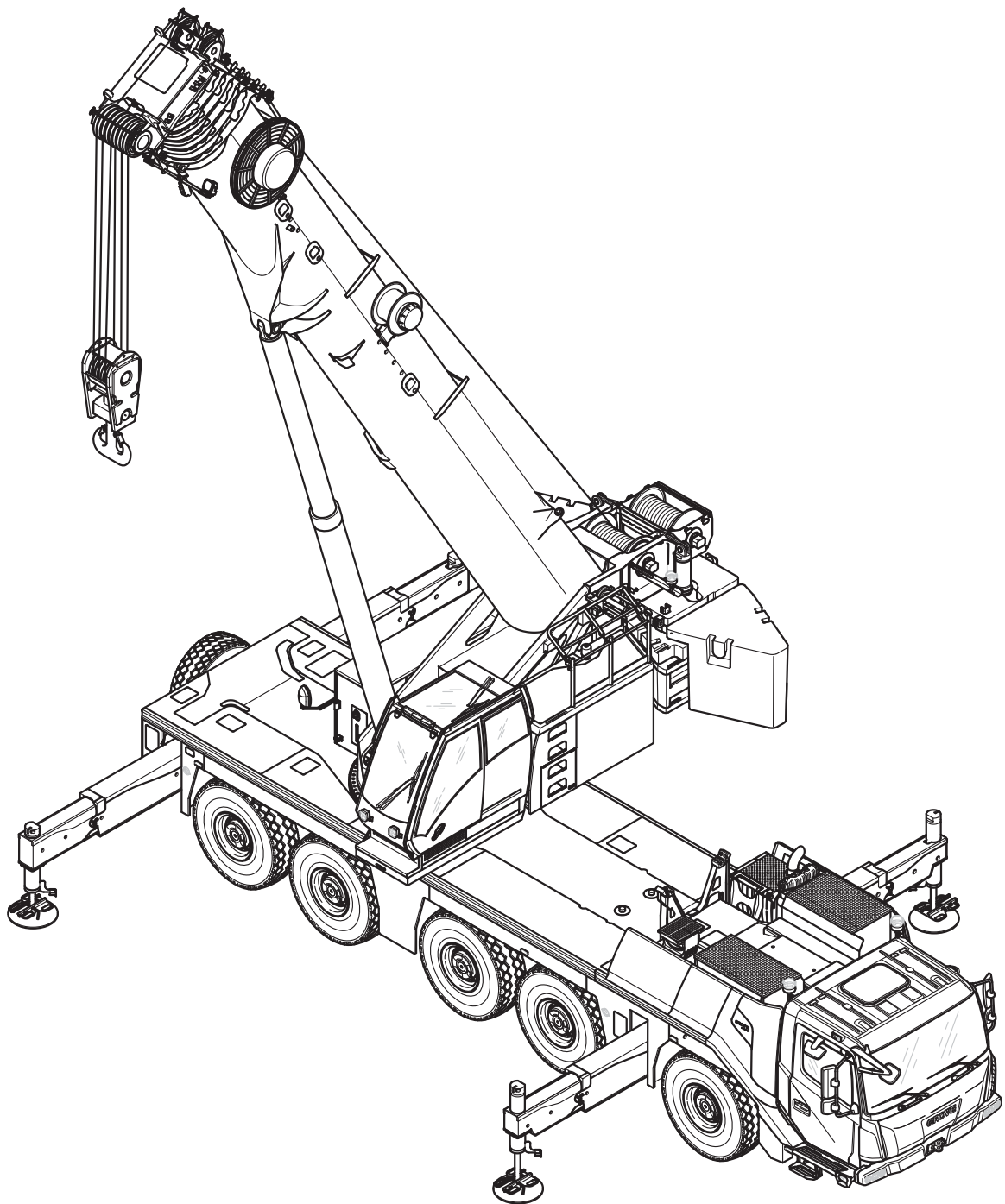

3 302 709 en  
12.01.2018

**Manitowoc**<sup>®</sup>

CLICK HERE TO **DOWNLOAD** THE COMPLETE MANUAL

- Thank you very much for reading the preview of the manual.
- You can download the complete manual from: [www.heydownloads.com](http://www.heydownloads.com) by clicking the link below



- Please note: If there is no response to CLICKING the link, please download this PDF first and then click on it.

CLICK HERE TO **DOWNLOAD** THE COMPLETE MANUAL

---

## 2 Basic safety instructions

2.1	Intended use .....	2 - 1
2.1.1	Improper use .....	2 - 2
2.2	Organisational measures .....	2 - 3
2.3	Personnel qualifications .....	2 - 5
2.4	Safety instructions for driving the truck crane .....	2 - 6
2.5	Safety instructions for crane operation .....	2 - 7
2.6	Instructions on transporting persons .....	2 - 10

---

## 7 Transport

<b>7.1</b>	<b>Transport with transport vehicle</b> .....	<b>7 - 1</b>
7.1.1	CHECKLIST: Checks before transport .....	7 - 2
7.1.2	Drive the truck crane on to the transport vehicle.....	7 - 4
<b>7.2</b>	<b>Transport by ship</b> .....	<b>7 - 6</b>

## 12 Rigging work

<b>12.1</b>	<b>Rigging work checklists for crane operation with the main boom</b> . . . . .	<b>12 - 1</b>
12.1.1	CHECKLIST: Rigging . . . . .	12 - 1
12.1.2	CHECKLIST: Unrigging . . . . .	12 - 7
<b>12.2</b>	<b>Choice of a suitable positioning site</b> . . . . .	<b>12 - 11</b>
12.2.1	Determining the required load-bearing area . . . . .	12 - 11
12.2.2	Safe distance from slopes and pits . . . . .	12 - 14
12.2.3	Earthing the truck crane . . . . .	12 - 15
12.2.4	Safe distance from overhead power lines . . . . .	12 - 16
<b>12.3</b>	<b>Rigging work after driving with a dolly</b> . . . . .	<b>12 - 19</b>
12.3.1	Switching off the boom floating position . . . . .	12 - 19
12.3.2	Switching off the slewing gear freewheel . . . . .	12 - 20
12.3.3	Switching off boom pre-tensioning . . . . .	12 - 21
<b>12.4</b>	<b>Connecting/disconnecting the hand-held control</b> . . . . .	<b>12 - 23</b>
<b>12.5</b>	<b>Starting the engine for rigging</b> . . . . .	<b>12 - 27</b>
12.5.1	Starting/shutoff the engine – with the hand-held control . . . . .	12 - 27
12.5.2	Starting/shutoff the engine – from the outrigger control units . . . . .	12 - 29
<b>12.6</b>	<b>Slewing range – only with the Standard slewing range type</b> . . . . .	<b>12 - 31</b>
12.6.1	Representation in the lifting capacity tables . . . . .	12 - 31
12.6.2	Enabled outrigger spans . . . . .	12 - 32
<b>12.7</b>	<b>Outriggers – Overview – MAXbase slewing range type</b> . . . . .	<b>12 - 33</b>
12.7.1	Definitions . . . . .	12 - 33
12.7.2	Representation in the lifting capacity tables . . . . .	12 - 35
12.7.3	Enabled outrigger spans . . . . .	12 - 36
<b>12.8</b>	<b>Outrigger operation</b> . . . . .	<b>12 - 41</b>
12.8.1	CHECKLIST: Extending the outriggers . . . . .	12 - 41
12.8.2	CHECKLIST: Retracting the outriggers . . . . .	12 - 43
12.8.3	Preparing the truck crane . . . . .	12 - 44
12.8.4	Setting the outrigger spans . . . . .	12 - 46
12.8.5	Extending/retracting outrigger beams . . . . .	12 - 49
12.8.6	Moving the outrigger pads into operating/driving position . . . . .	12 - 53
12.8.7	Enlarging the load-bearing area . . . . .	12 - 55
12.8.8	Extending/retracting supporting cylinders . . . . .	12 - 56
12.8.9	Levelling the truck crane on outriggers horizontally . . . . .	12 - 60
12.8.10	Levelling the free-standing truck crane . . . . .	12 - 64
12.8.11	Operating the axle raising system . . . . .	12 - 66
12.8.12	Outrigger pressure display . . . . .	12 - 68
<b>12.9</b>	<b>Rigging/unrigging the counterweight</b> . . . . .	<b>12 - 71</b>
12.9.1	Information on rigging . . . . .	12 - 71

## 1.2

## Branch offices

### 1.2.1

### Manitowoc Crane Care

If you need help or support with the operation on your truck crane, you can contact our branches at the following addresses **Manitowoc Crane Care**:

*<http://www.manitowoccranes.com>*

### 1.2.2

### Dealer list

Visit the following address for a global list of dealers:

*<http://www.manitowoccranes.com>*

## 1.3

## Warranty specifications

Please see the separately enclosed warranty certificate for information.

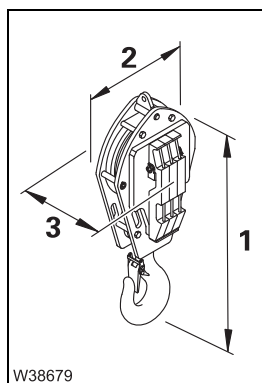

### Versions with ballast plate – Version A

Description	(1) x (2) x (3) in m	Weight In kg
Hook block 1 sheave <b>with</b> ballast plates	1.41 x 0.56 x 0.44 (4.63 x 1.84 x 1.44)	450
Hook block 1 sheave <b>without</b> ballast plates	1.41 x 0.56 x 0.35 (4.63 x 1.84 x 1.15)	325
1 ballast plate		19
Hook block 3 sheave <b>with</b> ballast plates	1.47 x 0.56 x 0.51 (4.82 x 1.84 x 1.67)	950
Hook block 3 sheave <b>without</b> ballast plates	1.36 x 0.53 x 0.30 (4.46 x 1.74 x 0.98)	440
1 ballast plate		25

### Auxiliary hoist

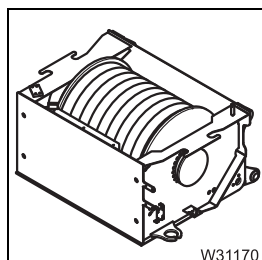

Description	Length x width x height in m (ft)	Weight in kg (lbs)
Complete auxiliary hoist	0.80 x 1.70 x 0.70 (2.62 x 5.58 x 2.29)	1,200 (2,646)



## 1.6

### Documentation supplied

The precise number of documents supplied depends on the rigging mode of the truck crane. The following documents are included in delivery:

– **Operating manual**

Contains information on driving and crane operation.

– **Lattice extension operating manual**

Is only supplied when the truck crane is equipped with a lattice extension or other parts for extending the main boom (for example, auxiliary single-sheave boom top and heavy load lattice extension).

– **Operating manual for additional equipment**

This is only supplied when the truck crane is supplied with additional equipment which is not described in the operating manual for driving and crane operation.

– **Documents from other manufacturers**

Original documentation for parts not manufactured by **Manitowoc Crane Group Germany GmbH**, such as the engine and central lubrication system, as well as the tachograph, auxiliary heaters, radio and, where appropriate, other additional equipment.

– **Maintenance manual**

Contains solely information on maintenance work and contains no instructions for repair work.

– **Safety manual**

Provides information on the safe operation of the truck crane.

– **Circuit diagrams**

Circuit diagrams for the electrical systems, hydraulic systems and pneumatic systems are supplied.

– **Lifting capacity table**

Information on the lifting capacity when the truck crane is in different rigging modes.



**1.8****Conversion table for US measuring units**

The following conversion factors will help you convert from metric to US units and vice versa when the truck crane is being used in countries that use US units of measurement.

<b>Converting from</b>	<b>into</b>	<b>Multiply by</b>
mm	into	0,03937
into	mm	25,4
m	ft.	3,28084
ft.	m	0,30479
m <sup>2</sup>	ft <sup>2</sup>	10,76391
cm <sup>2</sup>	in <sup>2</sup>	0,155
cm <sup>3</sup>	in <sup>3</sup>	0,061
ltr	gal (US)	0,264178
kg	lbs	2,204622
lbs	kg	0,45359
t	lbs	2,204.622
lbs	t	0,0004536
kN	lbf	224,809
daN/cm <sup>2</sup>	lbf/in <sup>2</sup>	14,50378
lbf/in <sup>2</sup>	daN/cm <sup>2</sup>	0,06895
bar	psi	14,50378
psi	bar	0,06895
m/s	ft/s	3,28084
km/h or km	mph or mi	0,62137
mph or mi	km/h or km	1,60935
Nm	lbf ft	0,7375
°C	°F	1.8 x °C+32
°F	°C	(°F-32)/1.8
t/m <sup>2</sup>	lbs/ft <sup>2</sup>	204,8
m <sup>2</sup> /t	ft <sup>2</sup> /lbs	0,04882

Appropriate servicing equipment is absolutely necessary in order to carry out maintenance work.

Observe national regulations that apply to transport when loading the truck crane. Also observe the additional safety measures prescribed by the forwarder (e.g. shipping or railway transportation company).

Monitor the work of personnel, at least occasionally, and make sure they work in accordance with the operating instructions in a safe and conscientious manner.

## 2.3

### Personnel qualifications

This operating manual is not a training manual for prospective crane operators!

All descriptions are written explicitly for crane operators who have been trained to operate truck cranes.

Personnel in training may only operate the truck crane under supervision.

Only reliable personnel may operate or carry out work on the truck crane.

As a crane operator you must fulfil a number of requirements:

- You must possess a driving licence for this type of vehicle that is valid in the country in which you are working.
- You must have general knowledge about working with cranes and the qualifications required in the country in which you are working.
- You must be familiar with and understand the operating instructions.
- You must be familiar with and have understood the accident prevention regulations.
- You must fulfil all physical and mental requirements for truck crane operation, e.g. perfect sight and hearing and the ability to react quickly.

Please also refer to the section in the *Safety manual* titled *You as driver and crane operator*.



<b>1</b>	Front flap	▣▣▣▣ p. 3 - 73
<b>2</b>	Driver's cab	▣▣▣▣ p. 3 - 6
<b>3</b>	Hose drum, installing/removing <sup>1), 2)</sup>	
<b>4</b>	Engine for driving	▣▣▣▣ p. 4 - 1
<b>5</b>	Rigging the main boom <sup>1)</sup> ,	▣▣▣▣ p. 6 - 17
<b>6</b>	Auxiliary hoist Operation <sup>1)</sup>	▣▣▣▣ p. 9 - 116
	Rigging the auxiliary hoist <sup>1)</sup>	▣▣▣▣ p. 6 - 39
<b>7</b>	APS connection/interface (Auxiliary Power Supply) <sup>1), 3)</sup>	
<b>8</b>	– Spare wheel <sup>1)</sup>	▣▣▣▣ p. 8 - 33
	– Towbar coupling <sup>1)</sup>	▣▣▣▣ p. 5 - 81
	– Third brake light – At the rear of carrier/storage compartment <sup>1)</sup>	▣▣▣▣ p. 5 - 12
	– Third brake light – At the spare wheel clamp <sup>1)</sup>	▣▣▣▣ p. 8 - 35
<b>9</b>	BirdView system 270° – Camera <sup>1)</sup>	▣▣▣▣ p. 3 - 53
<b>10</b>	Chocks <sup>1)</sup>	▣▣▣▣ p. 5 - 46
<b>11</b>	Storage space for the folding ladder	▣▣▣▣ p. 3 - 77
<b>12</b>	Outriggers	
	– Operation	▣▣▣▣ p. 12 - 41
	– Lighting	▣▣▣▣ p. 12 - 45
	– Installing/removing the outrigger beams	▣▣▣▣ p. 6 - 51
<b>13</b>	Swing-out ladders	▣▣▣▣ p. 3 - 77
<b>14</b>	– Fuel tank	▣▣▣▣ p. 4 - 5
	– Dual tank <sup>1)</sup>	▣▣▣▣ p. 4 - 6
<b>15</b>	– Outrigger control units	▣▣▣▣ p. 3 - 38
	– Emergency stop switch	▣▣▣▣ p. 4 - 19
<b>16</b>	Step at the crane cab Switching on/off	▣▣▣▣ p. 12 - 157

1) Additional equipment

2) ▣▣▣▣ *Lattice extension operating manual*

3) ▣▣▣▣ *Separate operating manual*



<b>1</b>	Indicator lamp for turn signal indicator	➡ p. 3 - 66
<b>2</b>	Indicator lamp for trailer turn signal indicator <sup>1)</sup>	➡ p. 3 - 66
<b>3</b>	Speedometer	➡ p. 3 - 70
<b>4</b>	On-board computer	➡ p. 3 - 15
<b>5</b>	Tachometer	➡ p. 3 - 43
<b>6</b>	Power steering malfunction	➡ p. 8 - 6
<b>7</b>	Malfunctions on the engine	➡ p. 8 - 19
<b>8</b>	Engine speed too high warning	➡ p. 3 - 43
<b>9</b>	Brake malfunction	➡ p. 3 - 58
<b>10</b>	ABS warning	➡ p. 5 - 35
<b>11</b>	Display:	
	– Time	➡ p. 3 - 73
	– Outdoor air temperature	➡ p. 3 - 73
<b>12</b>	Checking headlight – full beam	➡ p. 3 - 65
<b>13</b>	Check the retarder	
<b>14</b>	Clutch indicator	➡ p. 3 - 51
<b>15</b>	Parking brake indicator lamp	➡ p. 3 - 60
<b>16</b>	Parking light indicator	➡ p. 3 - 66
<b>17</b>	Kilometre counter	➡ p. 3 - 70
<b>18</b>	Fuel level display	➡ p. 4 - 5
<b>19</b>	Steering system warning	➡ p. 3 - 61
<b>20</b>	Steering malfunction	➡ p. 3 - 60
<b>21</b>	Steering circuit 1 warning	➡ p. 3 - 60
<b>22</b>	Steering circuit 2 warning	➡ p. 3 - 60
<b>23</b>	Steering circuit 3 warning	➡ p. 3 - 60
<b>24</b>	AdBlue (DEF) level indicator	➡ p. 4 - 7

<sup>1)</sup> Additional equipment

### 3.1.11

### CCS – Start menu

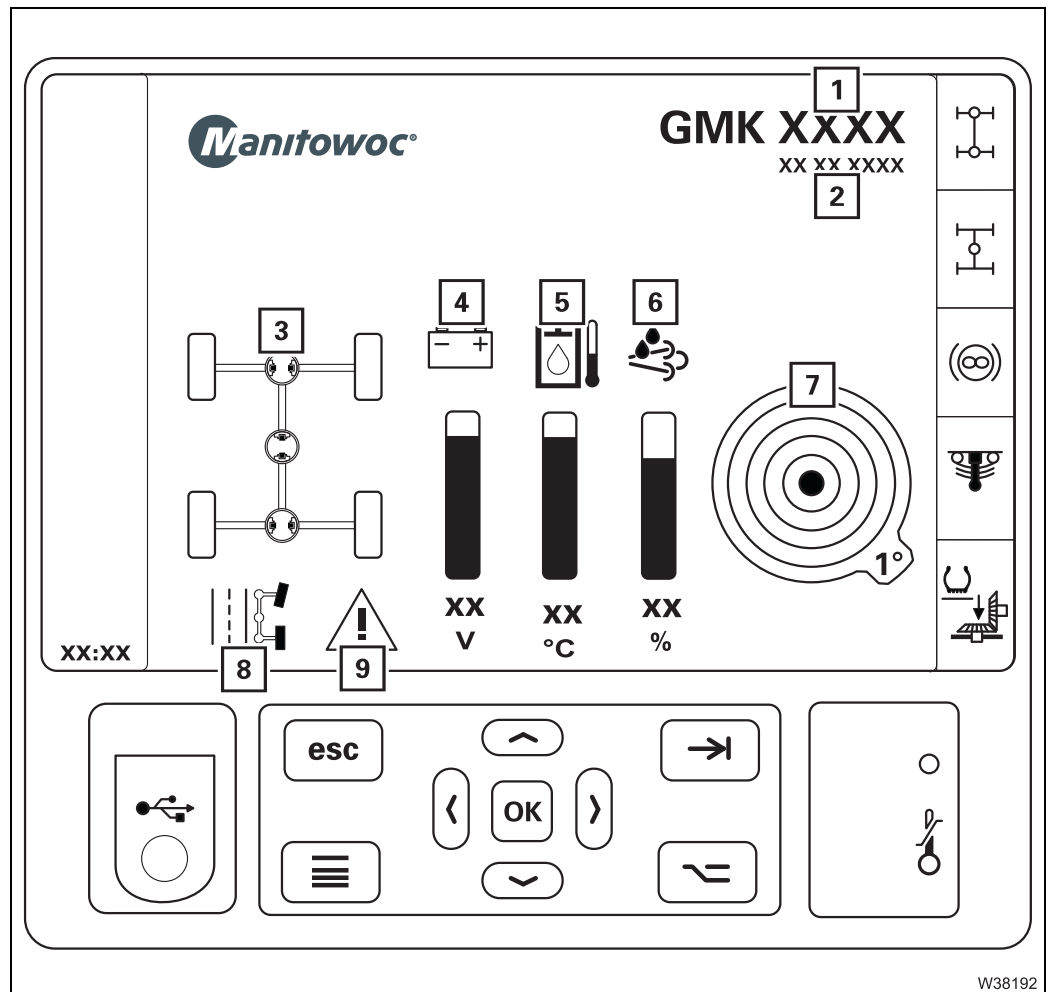

- 1 Display of crane type
- 2 Serial number display
- 3 Display of transverse and longitudinal differential locks on/off ▶▶▶▶ p. 3 - 28
- 4 Voltage monitoring display ▶▶▶▶ p. 4 - 15
- 5 Hydraulic oil temperature display ▶▶▶▶ p. 4 - 15
- 6 AdBlue level display ▶▶▶▶ p. 4 - 15
- 7 Display of current inclination ▶▶▶▶ p. 3 - 69
- 8 Steering mode display ▶▶▶▶ p. 3 - 62
- 9 Steering system malfunction/warning ▶▶▶▶ p. 3 - 62

## Operating hours menu

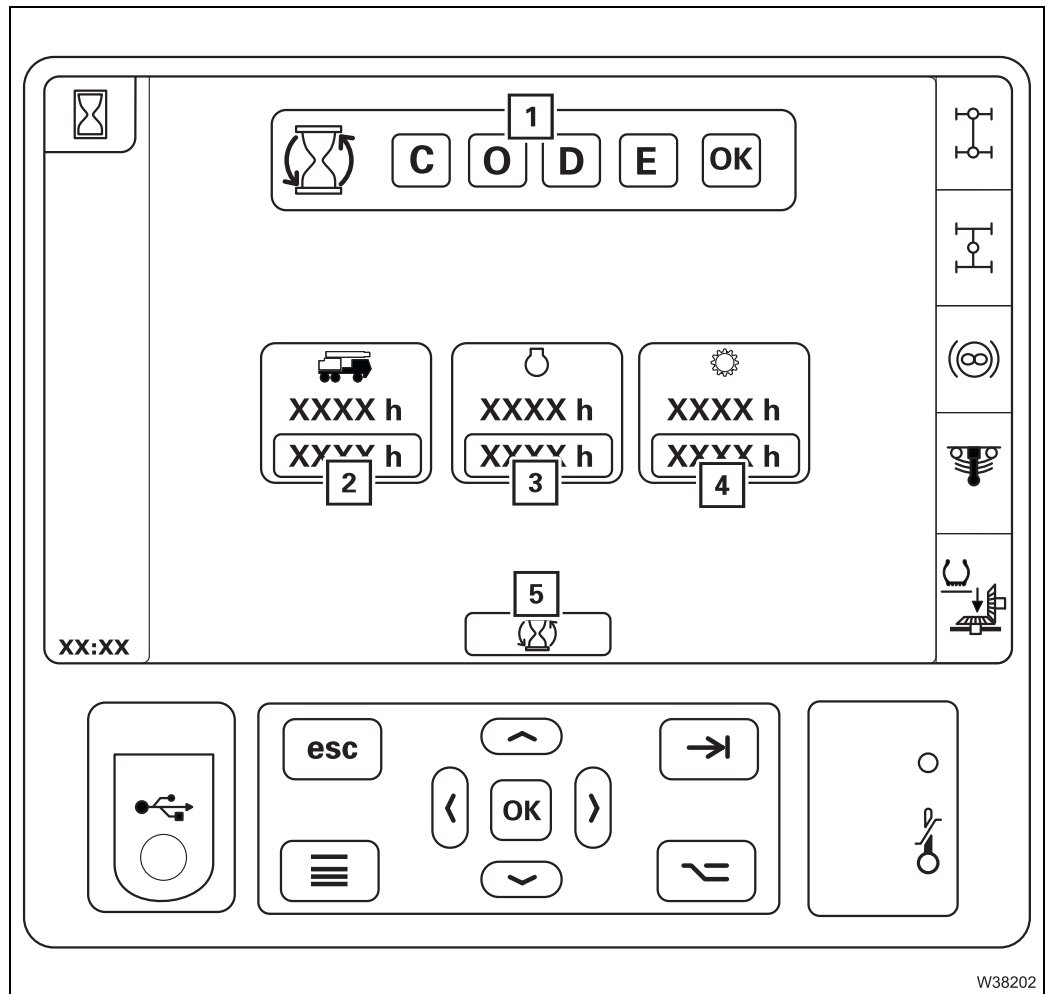

- |                        |                |
|------------------------|----------------|
| <b>1</b> Keycode input | ▣▣▣▣ p. 5 - 24 |
| <b>2</b> Carrier       | ▣▣▣▣ p. 5 - 24 |
| <b>3</b> Engine        | ▣▣▣▣ p. 5 - 24 |
| <b>4</b> Transmission  | ▣▣▣▣ p. 5 - 24 |
| <b>5</b> Selection all | ▣▣▣▣ p. 5 - 24 |



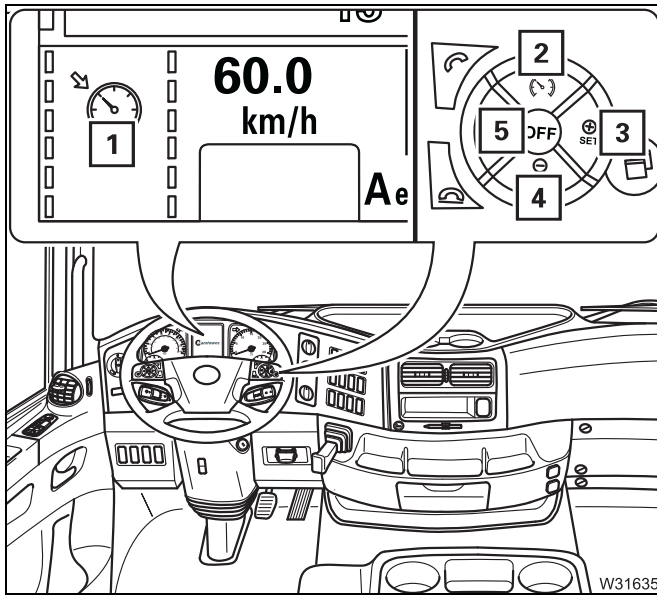

### Setting cruise control

The truck crane must be driving at a speed at least 15 km/h (9 mph).

- 2 Select the *Cruise control* menu – symbol (1) is **grey**
- 3 Switches on or increases the speed – symbol (1) is **white**
- 4 Switches on or reduces the speed
- 5 switch off

▣▣▣▣▶ p. 5 - 38

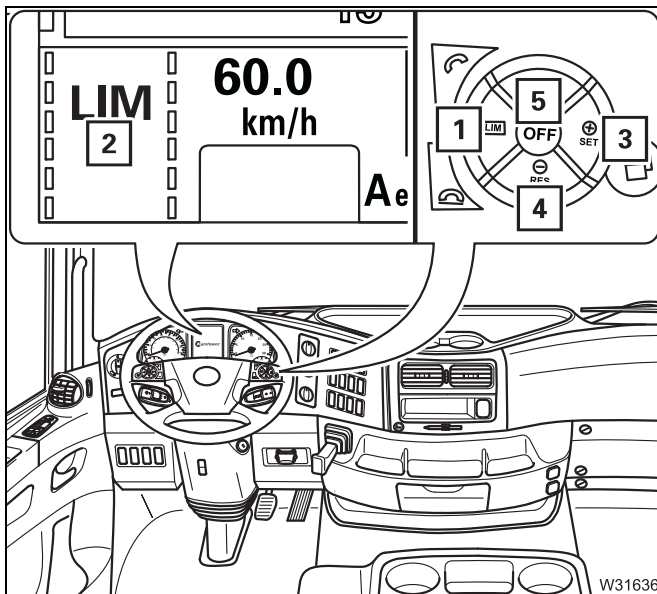

### Setting the Tempomet

The truck crane must be driving at a speed at least 15 km/h (9 mph).

- 1 Select *Tempomet* – symbol (2) is **grey**
- 3 Switches on or increases the speed limit – symbol (2) is **white**
- 4 Switch off or reduce the speed limit
- 5 Switch *Tempomet* off

▣▣▣▣▶ p. 5 - 40

## Instrument panel

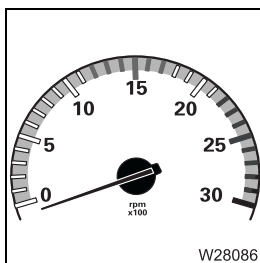

### Tachometer

Display, engine speed in rpm; ▣▣▣▣▶ p. 5 - 37

### 3.2.10

## BirdView system 270°

The BirdView system 270° is a driving assistance system.

The BirdView system 270° does not relieve you of the responsibility for maintaining a sufficient safe distance or braking in time! Drive with due care and attention! The sole responsibility lies with the crane operator.

**Manitowoc Crane Group Germany GmbH** explicitly states that no liability is accepted for damage resulting from a failure to observe these instructions.

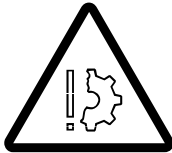

#### Risk of damage in driving mode

Obstacles in the driving area above the height of the camera are **not** displayed. Always also watch the driving area using the mirrors. This will avoid damage to the truck crane.

The BirdView system 270° shows rear and side views next to the carrier in the driver's cab.

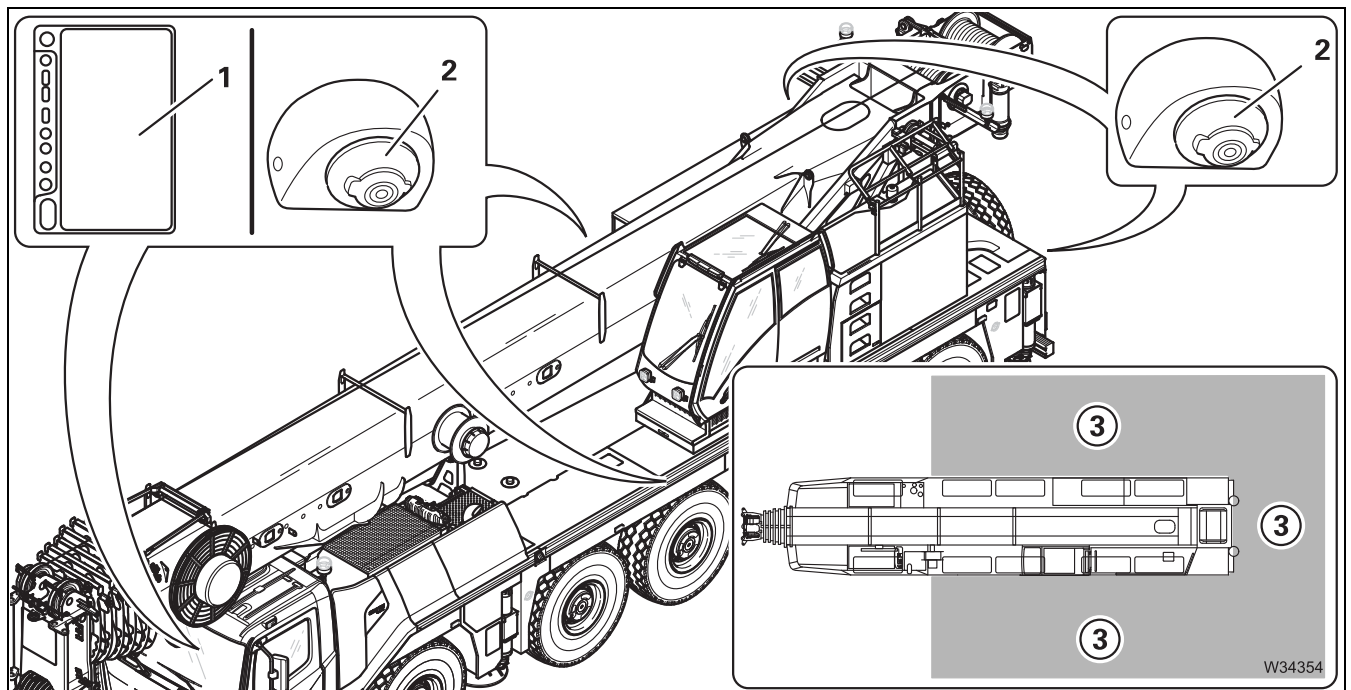

All cameras (2) simultaneous show images on the monitor (1).  
The monitor (1) shows the area (3) to the rear and side of the carrier.



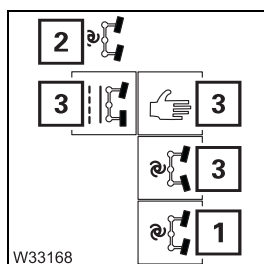

### Separate steering crab travel mode on/off

- **Switch on:** Select symbol (1) and confirm – Symbol (2) is displayed
- **Switch off:** Select a different steering mode – Symbol (3)

➡ p. 5 - 60

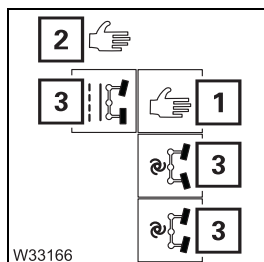

### Manual separate steering on/off

- **Switch on:** Select symbol (1) and confirm – Symbol (2) is displayed
- **Switch off:** Select a different steering mode – Symbol (3)

➡ p. 5 - 60

When separate steering is switched on, the speed is limited.

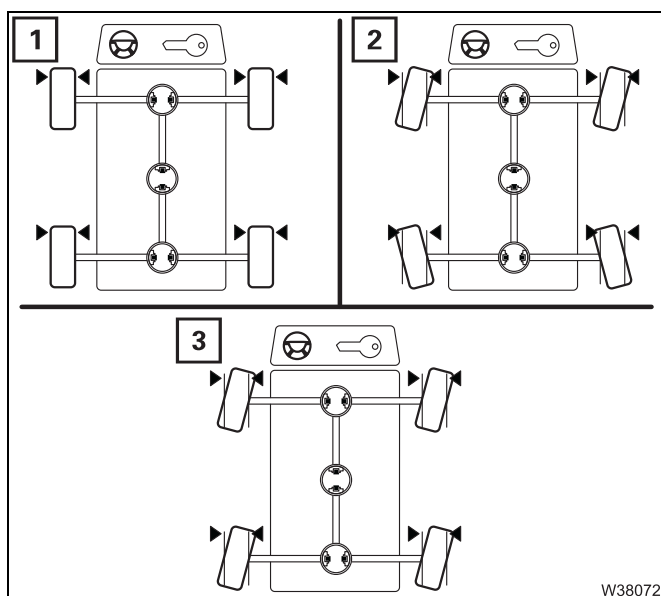

### Current wheel position display

The current status is shown using different symbols:

- 1 Straight ahead
- 2 Driving around corners
- 3 Crab travel mode

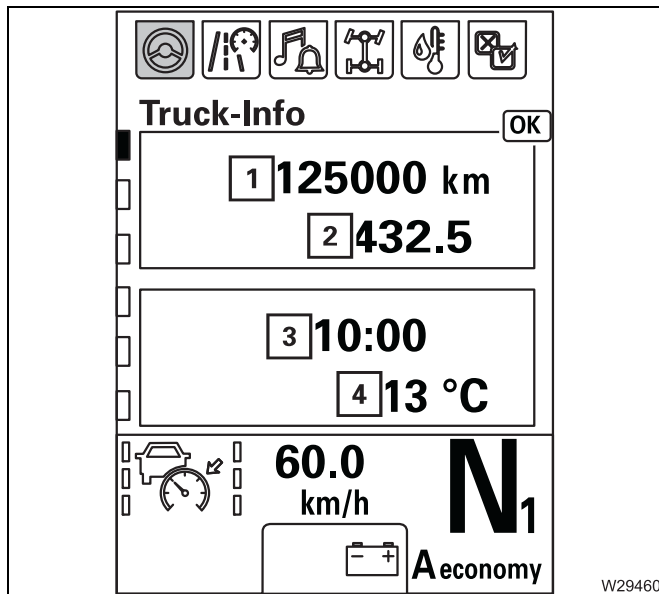

### Tour data menu

- 1 Total mileage
- 2 Daily mileage
- 3 Time
- 4 Outside temperature

### 3.2.22

### Front flap

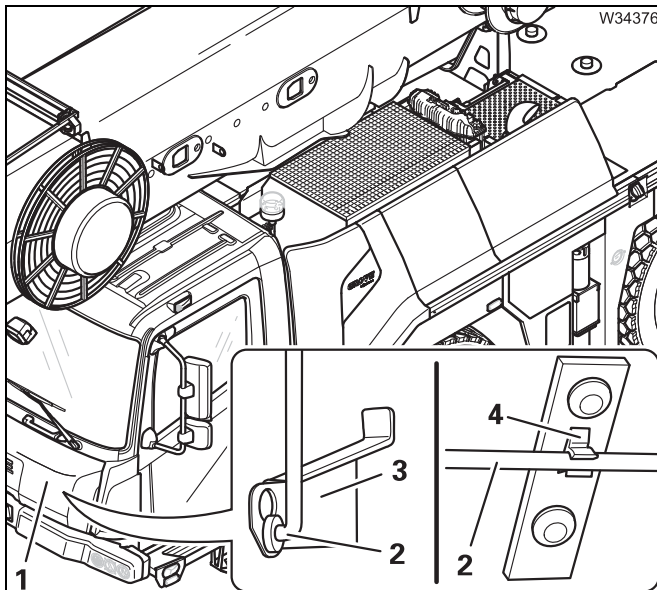

### Opening



- Fold up the front flap (1).
- Fasten the support (2) in the clamp (3).

### Closing

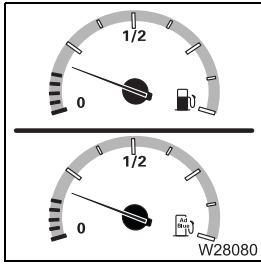
- Lift the front flap (1).
- Fasten the support (2) in the clamp (4).
- Fold down the front flap.
- Press the front flap against the driver's cab on both sides until you can hear it latch into place.



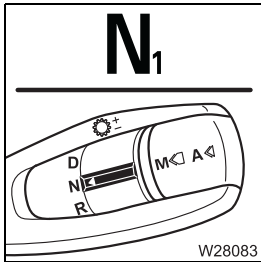

**10. Check the fluid supply:**

-  *Fuel tank*, p. 4 - 5,
-  *AdBlue tank*, p. 4 - 7
-  *Fuel tank auxiliary heater*, p. 11 - 5

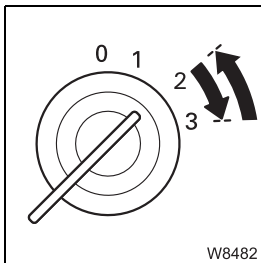

**11. Shift the transmission to neutral;  p. 5 - 26.**



**12. Start the engine;  p. 4 - 13.**

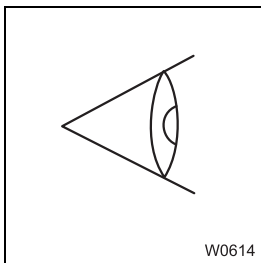

**13. Conduct the necessary checks after starting the engine;  p. 4 - 15.**

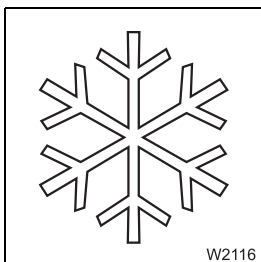

**14. In the event of low outside temperatures;  *CHECKLIST: At low temperatures*, p. 4 - 4.**

## 4.1.8

### Starting the engine



This section describes only how to start the engine from the driver's cab. You can also start the engine from the outrigger control units; p. 12 - 27.

Refer to the separate operating manual provided by the engine manufacturer for operating the engine. The engine can only be started if:

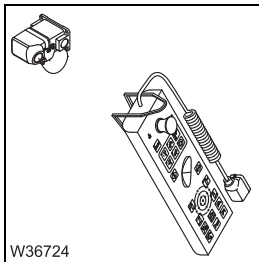

– The bridging plugs have been inserted in all sockets of the carrier and superstructure for the hand-held control; p. 9 - 83.



– The lamp (1) has gone out (superstructure ignition off).

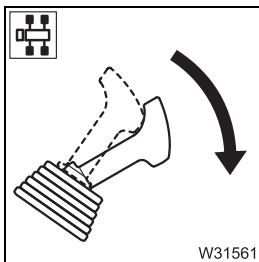

– The parking brake must be applied.

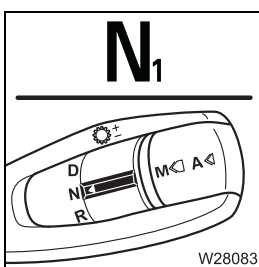

– The transmission must be in position **N**; p. 5 - 26.



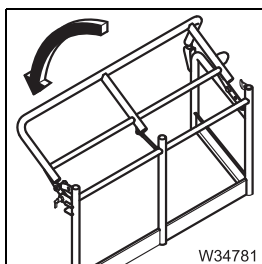

8. All railings must be folded in; p. 12 - 149.

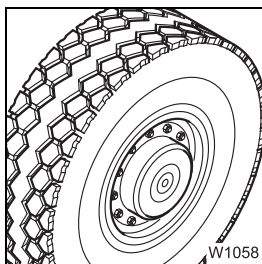

9. Check the tyres:  
– Tyre pressure when tyres are cold in on-road mode; p. 1 - 18.  
– Other checks; *Maintenance manual*.

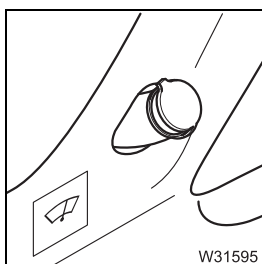

10. Check the level and function of the windscreen washing system;  
 *Maintenance manual*.

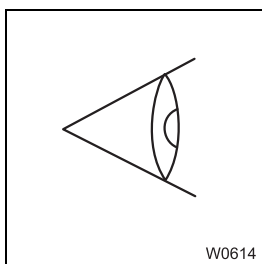

11. Carry out an inspection of the truck crane, looking out in particular for any leaks of fluids (oil, fuel or water).

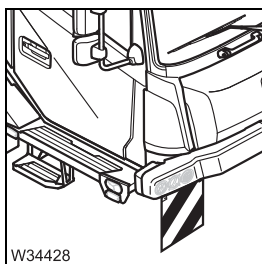

12. The warning signs for marking the vehicle width are folded down (only for vehicle widths of over 2.75 m (9.0 ft));  
Vehicle width; p. 1 - 8,  
Warning signs; p. 5 - 9.

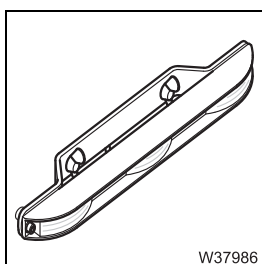

13. If necessary, check whether the third brake light is correctly connected;  
 p. 5 - 12.



### 5.1.3

## Adjusting the seat and the steering column

### Adjusting the driver's seat

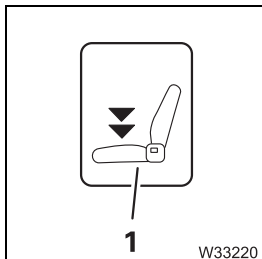

The seat height and lumbar support are adjusted pneumatically. You can only make these adjustments when:

- the switch (1) on the driver's seat is switched off (not pressed in),
- sufficient air pressure is available in the secondary consumer circuit. You may have to build up the supply pressure;  p. 5 - 10.

- Sit on the driver's seat; the seat will rise to the last position set.

You can make adjustments to suit your body size and shape.

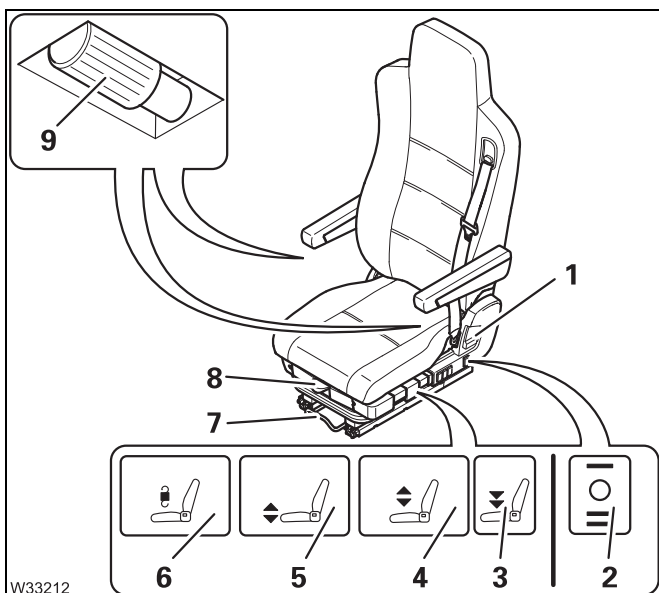

### Settings for body size

- 1 Back rest – angle
- 2 Seat heating on/off<sup>1)</sup>
- 3 Lower it to the lowest position
- 4 Seat – height
- 5 Seat – inclination
- 6 Spring hardness
- 7 Seat longitudinal adjustment
- 8 Seat cushion – longitudinal adjustment
- 9 Armrests – inclination<sup>1)</sup>

1) Additional equipment



## 5.1.6 Setting the time

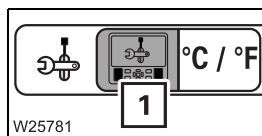

- Open the *Set display brightness and date/time menu (1)*.

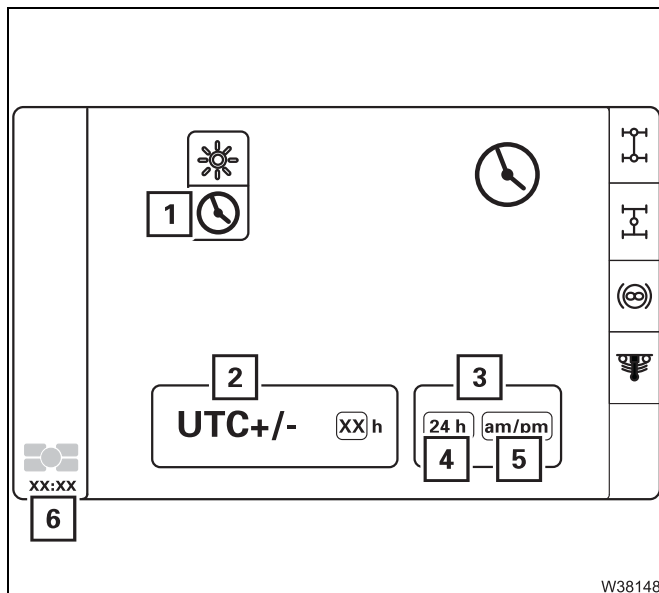

- Select and confirm the symbol (1).

### Setting the time

- Select and confirm the symbol (2).
- Select the current time – expressed as a deviation from UTC time.
- Confirm the selection. The newly set time is shown on the display (6).

### Switching the display type

- Select and confirm the display (3).
- Select the symbol for the desired display type.
  - 4 24 hours
  - 5 12 hours AM/PM

Confirm the selection, the selected display type becomes orange.

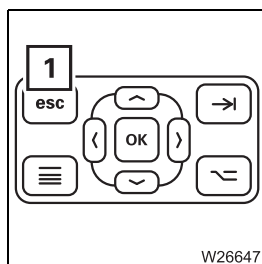

You can **cancel the input** at any time.

- Press button (1) – no values are changed.

## 5.2.7

### Changing the driving direction

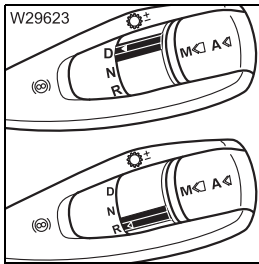

- Stop the truck crane.
- Shift to the position for the opposite direction.  
At a standstill, you can shift two levels in succession immediately.  
You do not need to wait for the intermediate position **N** to appear.

The newly engaged gear will be shown in the display.



Up to a speed of approx. 30 km/h, you can pre-select a reverse gear or forward gear when driving. The gear is switched when the truck crane comes to a stop. The shifting operation is complete when the display shows the selected gear.

## 5.2.8

### Stopping

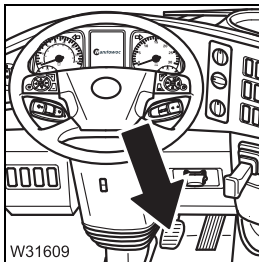

- In order to stop, remove your foot from the accelerator and actuate the brake pedal.

The transmission declutches shortly before the vehicle comes to a halt. The current gear remains engaged.

#### Stopping for longer periods

If you stop for more than 1 to 2 minutes with the engine running, you need to perform the following to protect the clutch:

- Apply the parking brake and
- Shift the transmission to neutral.

### Additional brakes

### Engine retarder

The truck crane has an engine flap brake which it uses as an engine retarder. The engine retarder only becomes effective at an engine speed of 950 rpm and can be used up to a maximum speed of 2,300 rpm.



#### Risk of accidents from unexpected acceleration

Maintain sufficient distance when the engine retarder is switched on. The effectiveness of the engine retarder is interrupted during gear shifting. This may cause the truck crane to accelerate briefly.

### Transmission retarder

The truck crane can also be rigged with a transmission retarder. The braking force of the transmission retarder depends on the speed. The higher the speed, the higher the braking power.



For long downhill stretches, we recommend that you use level 2. When the transmission retarder is switched on, you cannot regulate the speed with the accelerator.

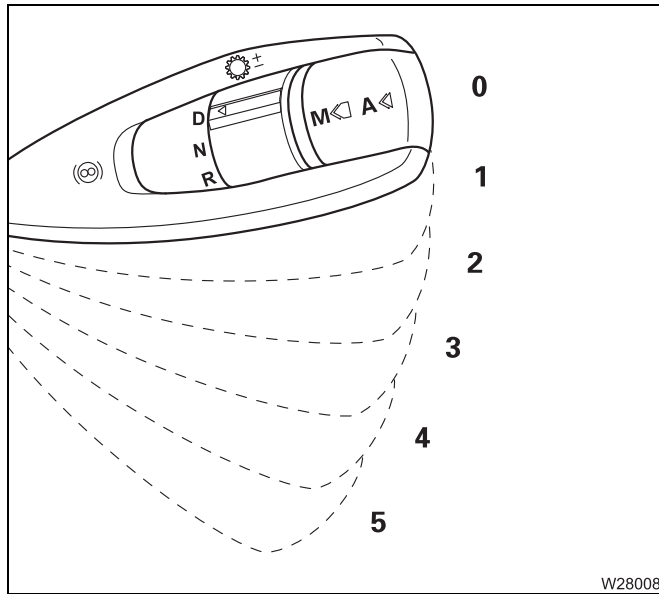

#### Switching on the additional brakes

- Pull the switch back to the required level (latch into place briefly at each level).
  - 1 20% brake power
  - 2 40% brake power
  - 3 60% brake power
  - 4 80% brake power
  - 5 100% brake power

#### Switching off the additional brakes

- Press the switch upwards to level 0.



When the additional brake is switched on, the lamp (1) lights up.

### 5.4.3

## Operating the level adjustment system

You can use the level adjustment system to set the on-road driving level, change the overall level and incline the truck crane.

### Open menu

You can only open the *Level adjustment system* menu when the current speed is less than about 5 km/h (3 mph).

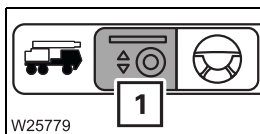

- Open the *Suspension/level adjustment (1)* menu.

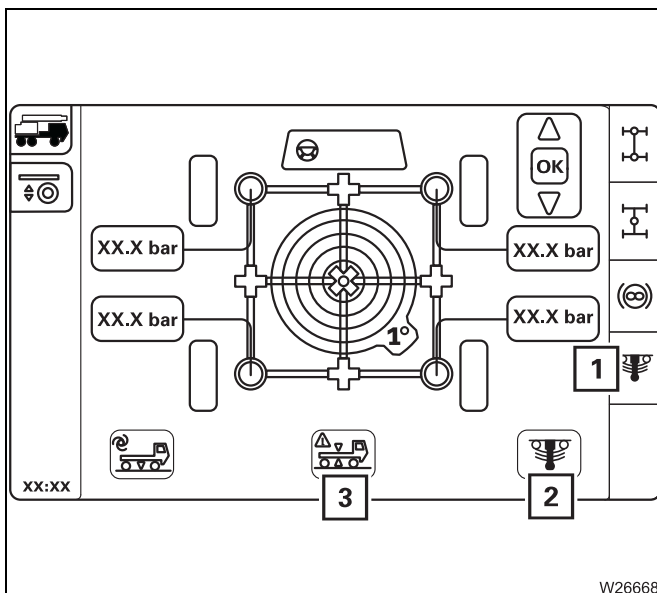

- Check that the symbol (1) is **green** (suspension on).
- If the symbol (1) is red then select and confirm the symbol (2) to switch the suspension on.

When the suspension has been switched on, you can:

- Set the on-road driving level
- Pre-select the suspension struts and change the vehicle level.

If the symbol (3) is shown for an error during a level adjustment, refer to **Manitowoc Crane Care**.



## 5.5.2 Switching to normal steering mode

After driving with separate steering, change over immediately to normal steering mode.

Switching off the separate steering is possible during standstill and while travelling, up to a speed of about 5 km/h (3 mph).

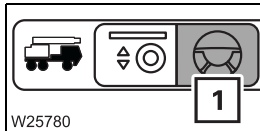

- Select and confirm the symbol (1).

The *Driving* menu opens.

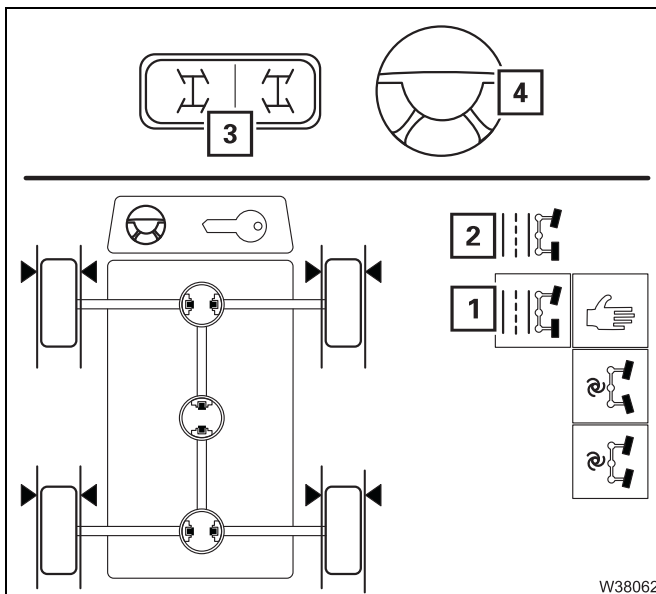

- Use the steering wheel (4) and the button (3) to turn the wheels to the *Straight ahead* position – the current wheel position is displayed.
- Select and confirm the symbol (1) – symbol (2) is displayed.



If the error symbol is displayed, contact **Manitowoc Crane Care**;  p. 8 - 24.



Always switch the auxiliary heater off if you switch off the truck crane whilst the battery master switch is switched on. In this way, you prevent the auxiliary heater from restarting and the batteries from running down after the engine has cooled down.

### Setting the date and time



If the error code **TEB** is shown in the display, the power supply has been interrupted for more than 8 minutes. You must reset the date and time.

Always set the current time and current day of the week. These settings are required for the correct activation point of the automatic heating start.

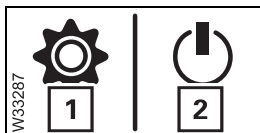

- Select and confirm the symbol *Settings* (1) – display symbol *Immediate start* (2).



- Select and confirm the symbol *Day of the week* (1) – display symbol (2), for instance **MON** for Monday.

- Select and confirm the desired day of the week.

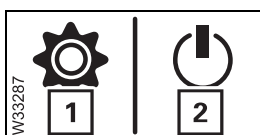

- Select and confirm the symbol *Settings* (1) – display symbol *Immediate start* (2).

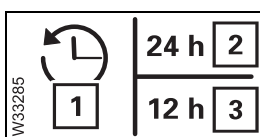

- Select and confirm the symbol *Time* (1) – display symbol *Time format*.
- Select and confirm the desired time format (2) or (3).



The *Time* display flashes.

- At the flashing display, set the hours and confirm the selection.





**Risk of accidents if the trailer is coupled improperly**

If the pin is protruding from the guide bushing, the trailer is not coupled properly and could become disengaged from the towbar coupling while driving.

**Connecting the supply lines**

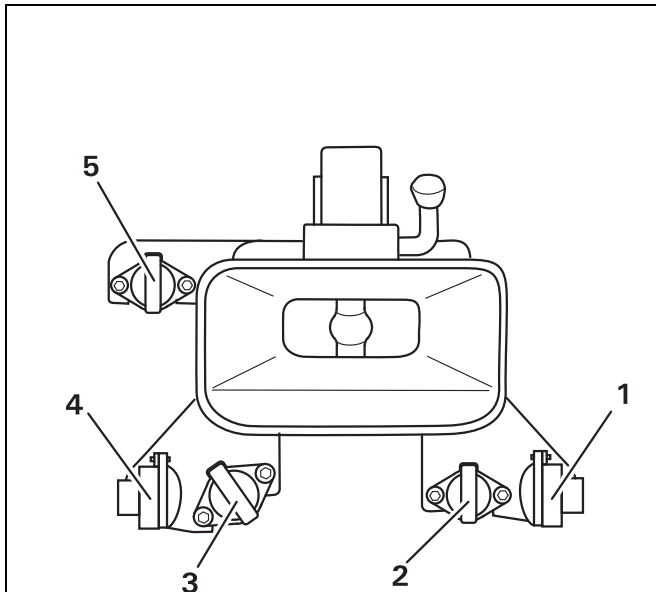

- Insert the plug of the trailer's electrical system into the socket (5).
- If necessary, insert the ABS connection cable into the socket (3).
- First connect the hose of the brake pipe to the yellow coupling head (4).
- Then connect the hose of the supply line to the red coupling head (1).

Socket (2) is designed for special equipment.



**Risk of accidents if the hoses are too short or installed improperly**

The hose lines may not come off even when driving around corners. When connecting the hoses, make sure they are long enough and have enough clearance.

- Check the function of the trailer lighting.
- Test the service brake and parking brake immediately after setting off.



## 6.2

# Weighing the truck crane

### Weighing error

The most precise method for determining the total weight of the GMK5150L is to use calibrated scales of appropriate capacity and a weighbridge on which all the wheels of the truck crane can stand at the same time.

All other weighing procedures are subject to various factors which can lead to weighing errors. This Operating manual describes a procedure by which the greatest number of sources of weighing errors can be avoided. Also observe all the instructions provided by the manufacturer of the scales.



#### Defective measurement of the axle loads and total weight.

When determining the axle loads and total weight, **do not** use individual dial scales. If individual dial scales are used to weigh a truck crane, this will lead to incorrect, unreliable measurement results.

If multiple individual scales are used, allowance must be made for the fact that the axle groups are hydraulically coupled. For this purpose, you will need wheel load scales of sufficient capacity and size.

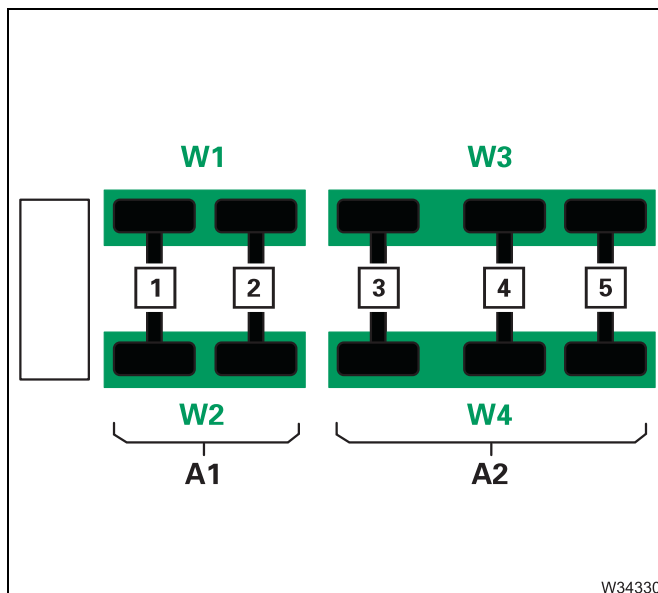

#### - Determining the total weight

The weights of all the axle groups belonging to the crane must be recorded at the same time in a single weighing procedure. In addition, only one set of scales may be used per axle group on each side of the vehicle. The GMK5150L has two coupled axle groups (A1 to A2) and you will require four wheel load scales (W1 to W4).



## 6.4

### Rigging the main boom

This section applies only to truck crane which are fitted with the pulling devices for removing/mounting the main boom.



#### **Risk of accident when removing/installing the main boom without pulling devices**

Only remove or install the main boom if the truck crane is equipped with the factory-installed pulling devices and with the necessary accessories. Without these factory-installed pulling devices, the main boom may be removed by **Manitowoc Crane Care** only.

#### **Additional equipment required**

In addition to the pulling devices, you also need the following accessories:

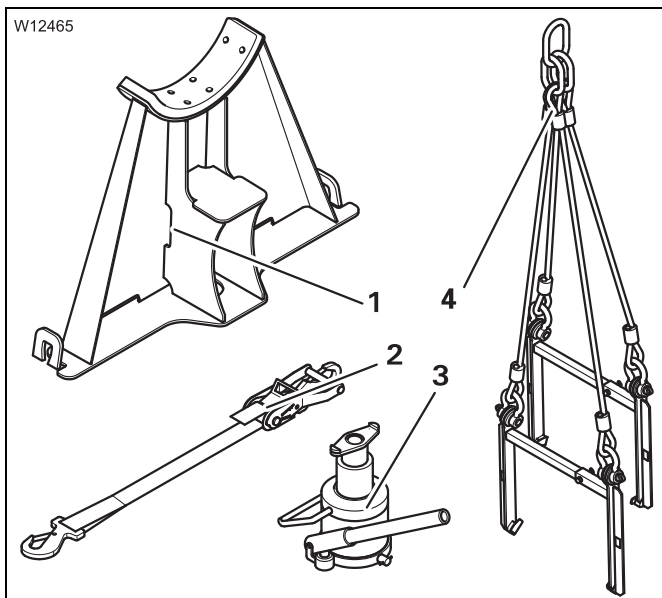

- a derricking cylinder support (1)
- a tightening belt (2)
- a lifting device (3)
- lifting gear (4)

as well as

- an auxiliary crane with sufficient lifting capacity,
- a separate vehicle with sufficient load bearing capacity and loading area.

Transport dimensions and weight;  
▣▣▣▣ p. 1 - 10.

### Attach lifting gear

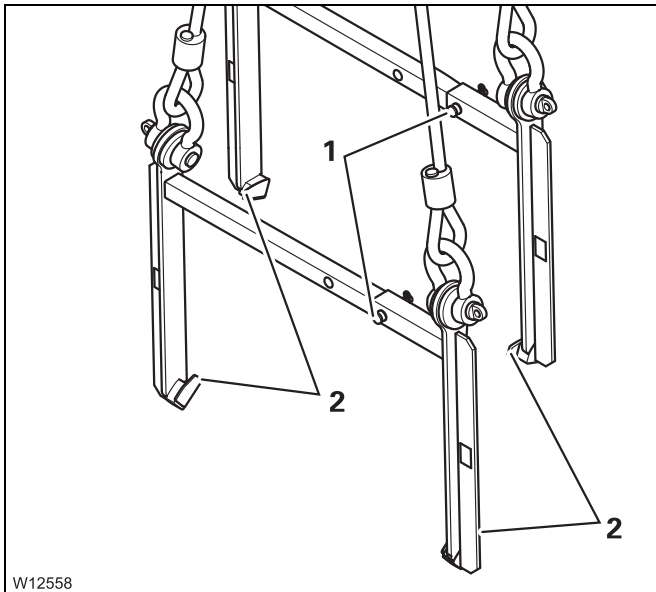

- If the installation is correct, the load-bearing equipment (2) of both brackets point to each other.
- Lock both brackets in the wide position. Secure the pins (1) using the retaining pins.
- Install the front bracket first. It hangs on longer ropes, which makes installing the back bracket easier.

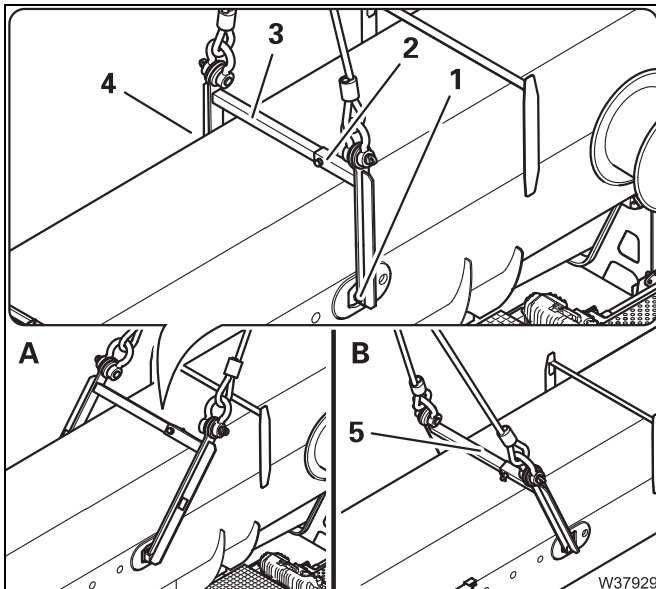

- Insert the bracket (3) into the slinging point (1). Pull the pin (2)
- Insert the bracket into the slinging point (4).
- Secure the bracket with the pin (2) and the retaining pin.
- (A) – Pull the bracket to the centre – the bracket must rest on the slinging point on both sides.
- (B) – Install the bracket (5) in the same manner

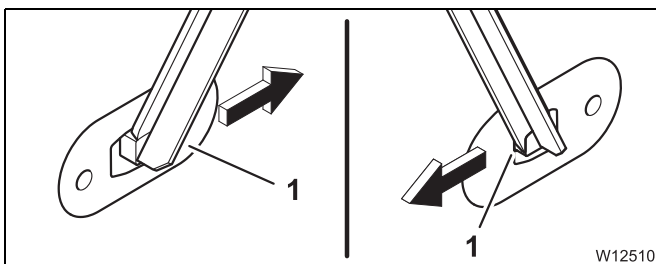

- (A) – Before lifting, make sure the brackets on both sides are resting on the slinging point (1)



## 6.4.12

### Inspections after main boom mounting

- Check to see if the pressure relief is switched off and is secured with the lock;  p. 6 - 29.

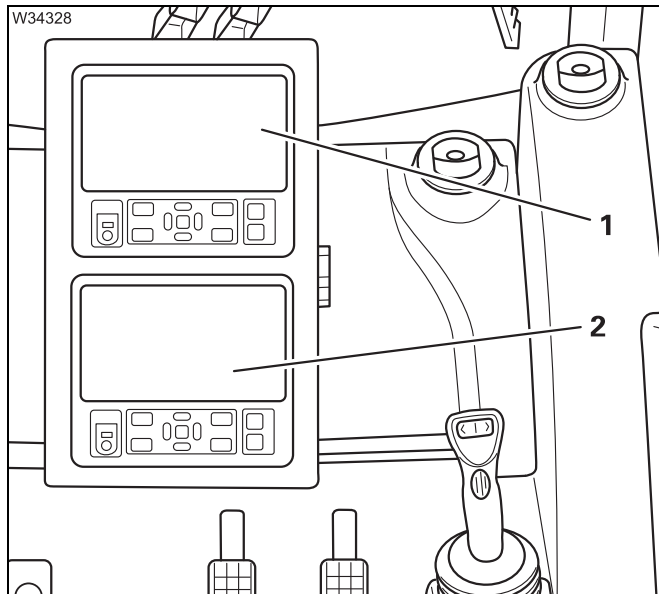

- Switch on the ignition.
- Check if the *RCL* (1) or *CCS* (2) control unit shows an error message.
- If an error message is displayed, check that all electrical connections are established;  p. 6 - 24.

The following requirements must be met for the subsequent inspection:

- The truck crane is on outriggers.
- The main boom is resting in the boom rest.
- The current rigging mode must have been entered and confirmed on the *RCL* display.

- Telescope the telescopic section about 1 m out and back in.
- Retract the telescoping cylinder into another telescopic section and mechanically lock it there.
- Check to see if the hydraulic connections in the turntable are sealed.



Before operating for the first time, carry out the movement *Incline lattice extension* with the hydraulically derricking lattice extension and check if the corresponding connections in the turntable are sealed.

Installing/removing the hose drum requires using an auxiliary crane with sufficient load-bearing capacity. The weight of the hose drum is about 170 kg (375 lbs).

## 6.5.9

### Check that the auxiliary hoist is functioning properly

#### Slewing direction

Check the slewing direction before laying on the hoist rope.



#### Risk of accidents due to incorrect slewing direction

Check after each installation that the slewing direction is correct.

This prevents accidents caused by the hoist rope winding up unexpectedly when it is applied.



#### Danger due to slack rope!

Only drive the auxiliary hoist briefly and at the lowest speed.

This prevents slack rope from being created, or the rope end fitting being pulled into the hoisting gear frame.

Ask someone to observe the slewing direction for you, or stand next to the auxiliary hoist and use the hand-held control.

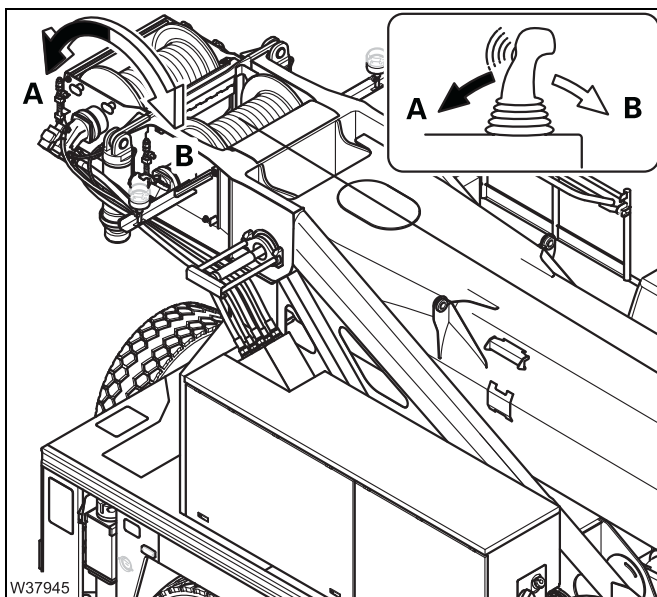

- Slowly perform the *Lift* and *Lower* movements – stop the movement as soon as the hoist drum turns.
- Check that the slewing direction is correct:

- A** Lifting
- B** Lowering

#### Slewing indicator

Check the function of the slewing indicator when applying the hoist rope.

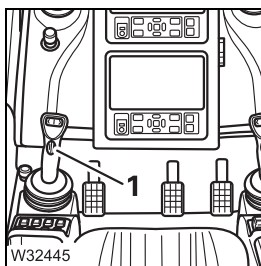

- You should feel a pulse on the slewing indicator (1) when the auxiliary hoist is rotating.
- If no pulse is present, contact **Manitowoc Crane Care**.



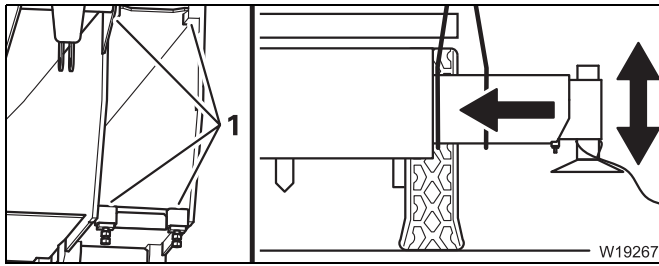

- Lift the outrigger beam as far as possible into the outrigger box. Correct the height so that it does not remain hanging on the edges (1).

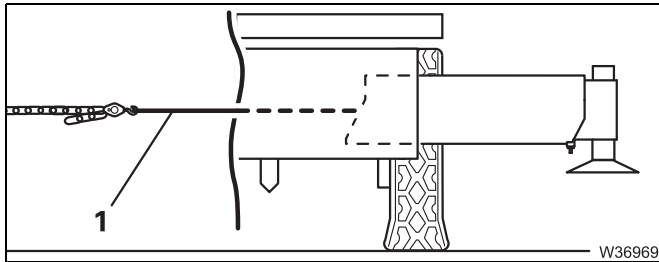

- Remove the lifting gear from the centre of gravity.
- Fasten a chain hoist to the lifting gear (1).

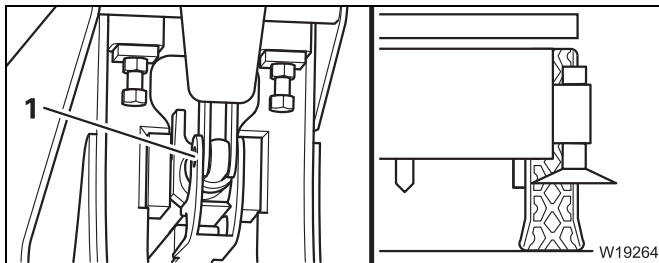

- Pull the outrigger beam in so far until the connecting points (1) align.
- Remove the chain hoist and lifting gear.

## 8.2.2

### Procedure during engine malfunctions

In the event of engine malfunctions, the electronic system will try to establish a secure operating condition with the remaining functions.

A text message is also displayed in addition to a symbol on the on-board computer display;  *Warning and malfunction messages on the on-board computer display, p. 8 - 9.*

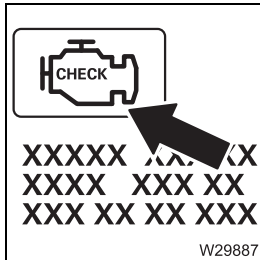

#### Engine malfunction

One or more systems have a malfunction:

- Engine
- Engine cooling system
- Engine control
- Fuel system
- Drive on until you have a chance to stop.
- Stop immediately and switch the engine off.



#### Risk of damage to the engine

Switch off the engine immediately the truck crane has come to a stop. Do not by any means restart the engine. This will prevent serious damage to the engine.

- If necessary, note the error messages and contact **Manitowoc Crane Care** or a qualified specialist repair shop.

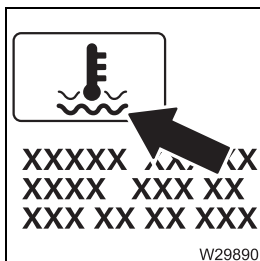

The coolant temperature is too high – the motor output is automatically reduced.

- Reduce speed.
- Drive on until you have a chance to stop.
- Stop immediately and switch the engine off.

### 8.3.3

## Warning messages on the CCS display

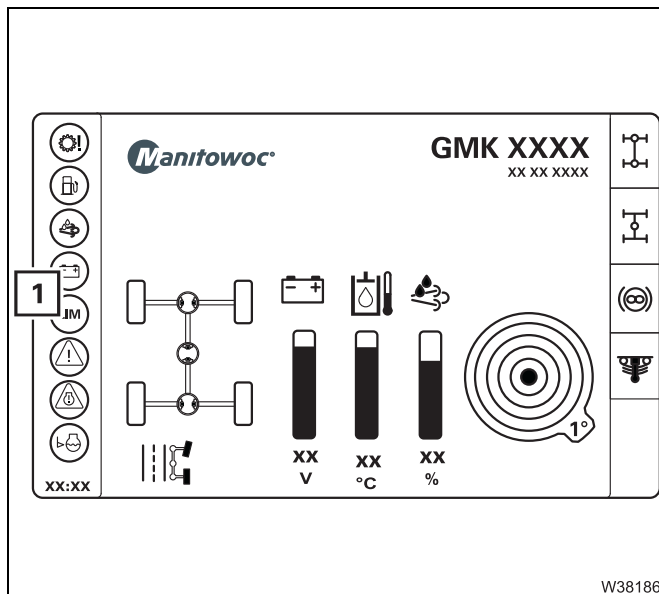

A warning message indicates that certain values do not correspond to a target value. If CCS detects a warning or a fault then in the display area (1) a symbol is displayed.

### Meaning of the symbols

The colour of the symbols indicates whether a warning or malfunction message is active in the corresponding area.

- Symbol **yellow** – malfunction.
- Symbol **red** – warning message.
- **No** symbol – no malfunction or warning message.

If a symbol is displayed in **red** or **yellow**, perform the following checks.



### Risk of damage if warning messages are disregarded!

Observe the following information in good time and take the appropriate remedial measures if a warning message appears. This prevents these malfunctions causing defects in the truck crane.

### Symbols in the display area

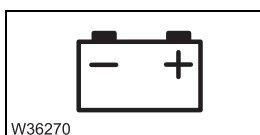







### Voltage monitoring

The voltage in the electrical system is too high or too low. Display of the current voltage;  p. 4 - 17.



## 8.4.5

## Malfunctions in the transmission

Malfunction		Cause	Solution
Transmission only shifts up to 2nd gear – the symbol is displayed		Transmission oil too hot	Switch to the neutral position and wait until the transmission oil has cooled down
		Transmission oil colder than about -7 °C (20 °F)	Wait until transmission oil temperature rises
Transmission is not upshifting at speeds over about 20 km/h (12 mph)		A locking procedure is not yet completed	Switch off differential locks;  p. 5 - 52
Transmission not shifting – the symbol is displayed		Retarder switched on	 <i>Switching off the additional brakes</i> , p. 5 - 43
The transmission does not respond to the controls		Fuse F1/6 blown	Replace blown fuses;  p. 8 - 49
		Transmission cannot shift down as otherwise the maximum permissible engine speed would be exceeded.	Braking the truck crane
Driving display indicates a malfunction		The electronic gear system has detected a malfunction	 <i>Procedure during transmission malfunctions</i> , p. 8 - 4
Transmission diagnostics plug not working		Fuse F1/2, F6/5 blown	Replace blown fuses;  p. 8 - 49



Further information;  *Warning messages on the CCS display*, p. 8 - 13.

## 8.5.4

### Wheel change

- If a puncture occurs while driving, stop the truck crane, taking the following traffic into account, and secure the truck crane as outlined in the applicable legal stipulations of the country in which you are working.
- Select as flat a place as possible to change the wheel.



#### **Risk of accidents due to a wheel falling over**

If you temporarily lean a wheel against the truck crane while changing it, secure it with a rope to prevent it falling over.  
Move the outriggers only when no wheel is leaning against the truck crane.

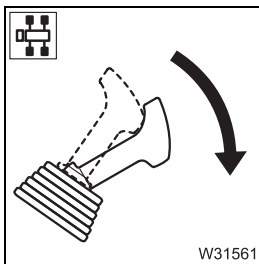

- Apply the parking brake.



#### **Risk of crushing due to turning wheels**

When you start the engine, no persons may be within the steering range of the 3rd and 5th axle lines. These axle lines can be briefly steered during the start of the engine; sometimes with five seconds delay.



## 8.6

### Tilting/lowering the driver's cab

To tilt the driver's cab (e.g. for maintenance work), the main boom must be raised and the hoisting gear moved.

This assumes that the engine can be started.



If the engine cannot be started, you must use the hydraulic emergency operation to lift the main boom;  p. 14 - 51.

### 8.6.1

#### Prerequisites and information on tilting

Before tilting the driver's cab, the following requirements must be met:

- The truck crane must be level.
- All loose objects must be removed from the driver's cab.
- The main boom is raised to the extent (about 1.5 m (4.9 ft)) that the driver's cab will not touch the main boom (nor the hose drum) when tilting!
- Ensure that the hook block is outside the driver's cab slewing range and the windscreen.



#### **Risk of damage to the steering's universal joint**

The steering wheel may only be moved when the driver's cab is lowered and locked. When moving the steering wheel into other driver's cab positions, the steering's universal joint can be damaged.

Designation	Amperage (A)	Function
F6/1	5	Engine emergency stop switch Tachograph, instrument panel
F6/2	3	Control unit CCM 11 Control unit IOL 31/32/33
F6/3	3	Display CCS Reverse camera Radio
F6/4	5	Air intake inhibitor
F6/5	10	Gearbox control
F6/6	5	Engine/transmission diagnostics plug
F6/7	3	<i>Outrigger</i> control unit left/right Inclination transmitter
F6/8	3	Engine electronic control system AdBlue system

Designation	Amperage (A)	Function
F7/1	3	Alternator
F7/2	3	Brake circuits 1 and 2
F7/3	3	Auxiliary heater time switch
F7/4	15	Retarder
F7/5	5	Horn Soot particle filter
F7/6	-	Unassigned
F7/7	10	Operating the mirror adjustment Window winder
F7/8	-	Unassigned



1 Side panel	▣▣▣▣▶ p. 9 - 8
2 Sun visor	
3 Current degree of utilisation display <sup>1)</sup>	▣▣▣▣▶ p. 11 - 51
4 Door unlocking mechanism	▣▣▣▣▶ p. 9 - 155
5 Lock/unlock windows	▣▣▣▣▶ p. 9 - 154
6 Air vents	▣▣▣▣▶ p. 11 - 152
7 Emergency stop switch	▣▣▣▣▶ p. 9 - 100
8 Windscreen washing system tank <sup>2)</sup>	
9 Adjusting the front panel	▣▣▣▣▶ p. 11 - 9
10 RCL control unit ( <b>R</b> ated- <b>C</b> apacity- <b>L</b> imiter)	▣▣▣▣▶ p. 9 - 76
11 CCS control unit	▣▣▣▣▶ p. 9 - 16
12 Service brake <sup>1)</sup>	▣▣▣▣▶ p. 9 - 162
13 Accelerator pedal	
14 Left-hand control panel	▣▣▣▣▶ p. 9 - 12
15 Right-hand control panel	▣▣▣▣▶ p. 9 - 13
16 Handle	
17 Crane cab seat	▣▣▣▣▶ p. 11 - 8
Seat contact switch	▣▣▣▣▶ p. 9 - 94
18 Rest	
19 Ignition lock	▣▣▣▣▶ p. 9 - 91
20 Cigarette lighter (24 volts)	
21 Ashtray	
22 Slewing gear freewheel <sup>1)</sup>	▣▣▣▣▶ p. 9 - 118
23 Slewing gear brake pedal – can be switched on/off <sup>1)</sup>	▣▣▣▣▶ p. 9 - 119
24 Crane cab, rear	▣▣▣▣▶ p. 9 - 10

<sup>1)</sup> Additional equipment

<sup>2)</sup> ▣▣▣▣▶ *Maintenance manual*



<b>1</b>	Display CCS	➡ p. 9 - 95
	Overview start menu	➡ p. 9 - 19
<b>2</b>	Jog dial	
<b>3</b>	Exiting the menu/input mode	➡ p. 9 - 98
<b>4</b>	Selecting / deselecting favourites	➡ p. 9 - 99
<b>5</b>	Warning for lifting limit switch shutdown	➡ p. 9 - 116
<b>6</b>	Sensor for brightness	➡ p. 9 - 98
<b>7</b>	Menu control	➡ p. 9 - 95
	Select / activate / confirm	
<b>8</b>	Display temperature warning display	➡ p. 9 - 99
<b>9</b>	Service/diagnosis connection <sup>1)</sup>	➡ p. 9 - 156
<b>10</b>	Overview menu groups – Operation	➡ p. 9 - 98
	Overview menu groups – Overview	➡ p. 9 - 22
<b>11</b>	Switch off the RCL buzzer	➡ p. 9 - 98
<b>12</b>	Slewing gear brake engaged/released	➡ p. 9 - 119
<b>13</b>	Function only in the menu Outtrigger	➡ p. 9 - 29
<b>1</b>		

<sup>1)</sup> For Service personnel only, not suitable for external devices, e.g. mobile phone

## Superstructure lock sub-menu

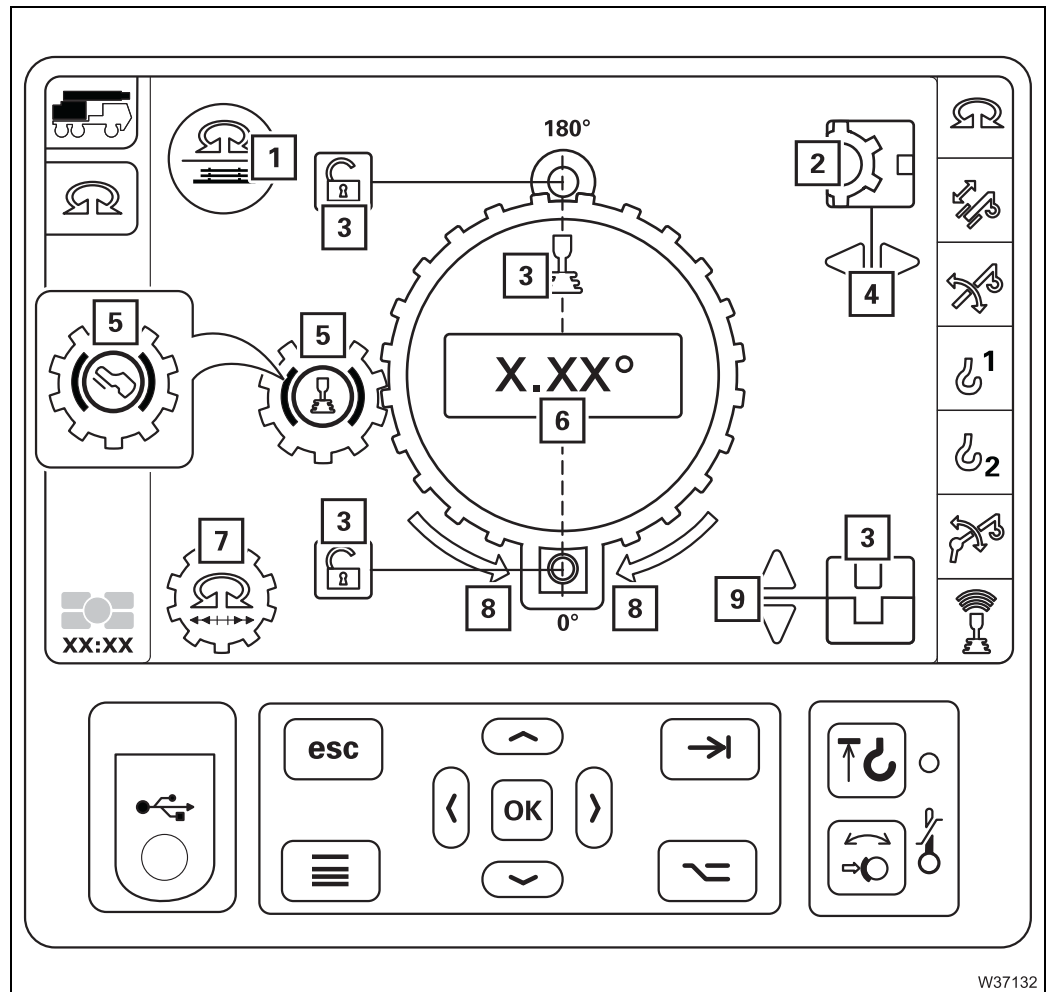

- 1 Slewing release display – identical to the display in the *Counterweight* menu ➡ p. 9 - 28
- 2 House lock locking status displays<sup>1)</sup> ➡ p. 9 - 131
- 3 Locking status displays ➡ p. 9 - 129
- 4 House lock on/off<sup>1)</sup> ➡ p. 9 - 131
- 5 Display/switch function for the slewing gear brake ➡ p. 9 - 119
- 6 Current slewing angle display<sup>1)</sup> ➡ p. 9 - 130
- 7 Slewing speed reduction on/off ➡ p. 9 - 119
- 8 Display slewing direction to 0°/180° ➡ p. 9 - 130
- 9 Locking/unlocking the turntable<sup>1)</sup> ➡ p. 9 - 129

<sup>1)</sup> Additional equipment



**9.1.11**

**RCL/Telescoping menu group**

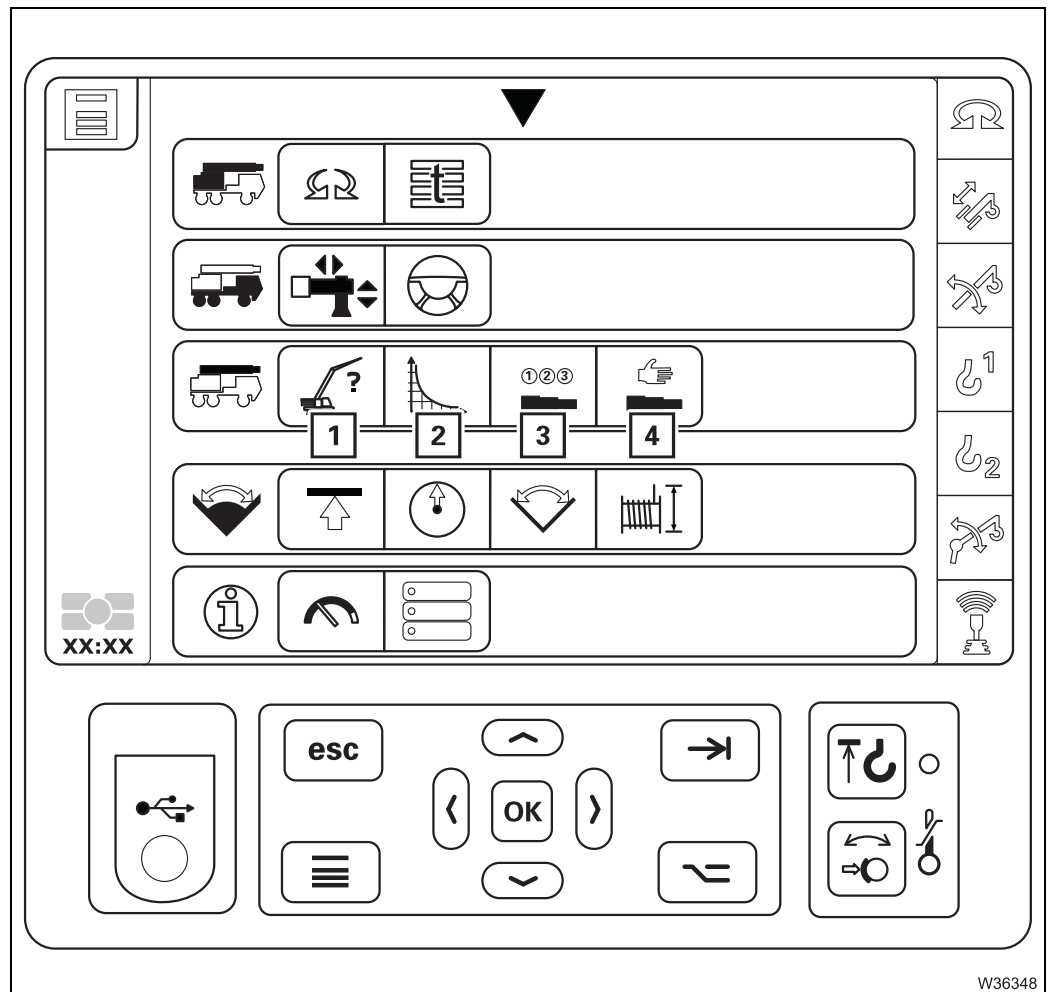

W36348

- |                                            |                 |
|--------------------------------------------|-----------------|
| <b>1</b> Menu enter rigging mode/telescope | ▣▣▣▣▶ p. 9 - 38 |
| <b>2</b> Lifting capacity tables menu      | ▣▣▣▣▶ p. 9 - 44 |
| <b>3</b> Telescoping semi-automation menu  | ▣▣▣▣▶ p. 9 - 45 |
| <b>4</b> Manual telescoping menu           | ▣▣▣▣▶ p. 9 - 46 |



## 9.1.12

### Working range limiter menu group

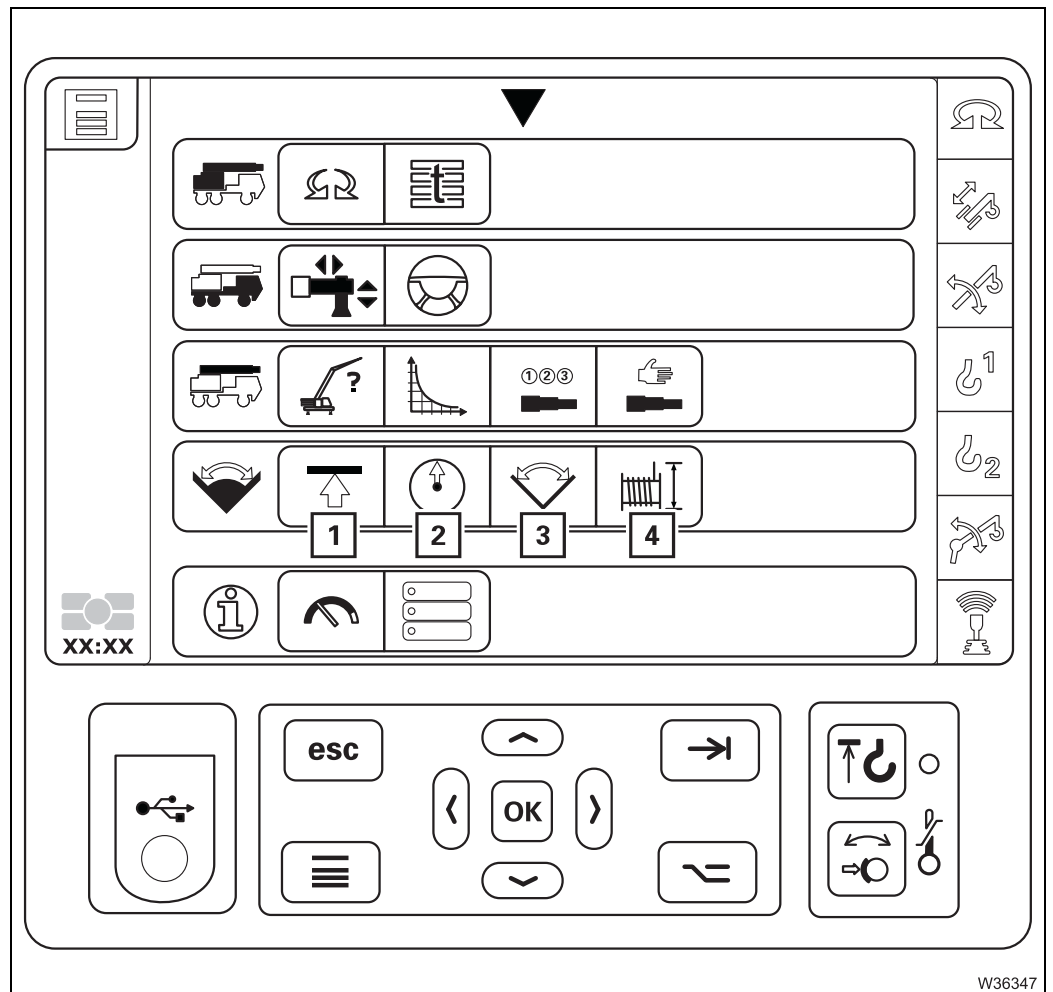

- |                                     |                 |
|-------------------------------------|-----------------|
| 1 Overall height menu               | ▣▣▣▣▶ p. 9 - 48 |
| 2 Working radius menu               | ▣▣▣▣▶ p. 9 - 49 |
| 3 Slewing angle menu                | ▣▣▣▣▶ p. 9 - 50 |
| 4 Hoist rope travel limitation menu | ▣▣▣▣▶ p. 9 - 51 |



## Heating/air-conditioning menu

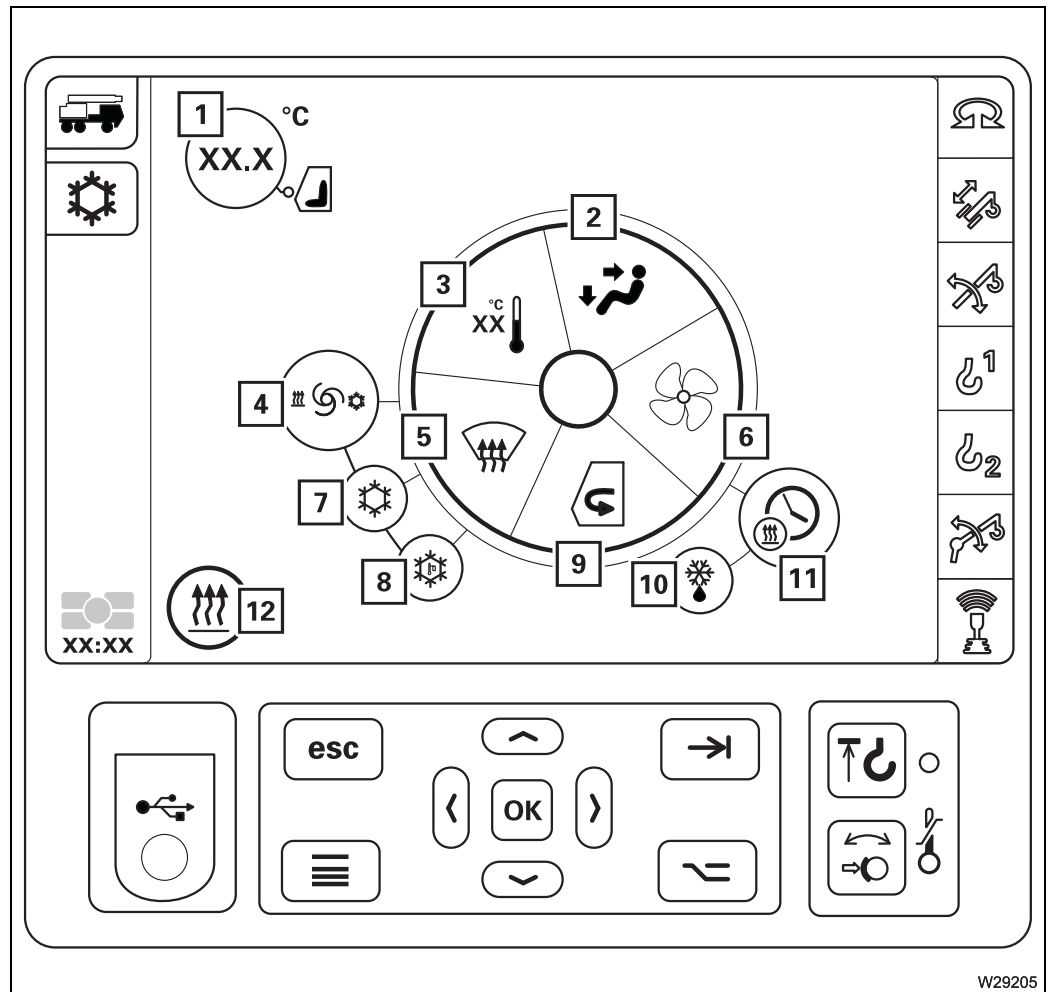

W29205

- |                                     |                  |
|-------------------------------------|------------------|
| 1 Outdoor temperature display       | ▣▣▣▣ p. 11 - 151 |
| 2 Air distribution                  | ▣▣▣▣ p. 11 - 152 |
| 3 Setting the temperature           | ▣▣▣▣ p. 11 - 151 |
| 4 Automatic air-conditioning system | ▣▣▣▣ p. 11 - 154 |
| 5 Defrosting the windscreen         | ▣▣▣▣ p. 11 - 151 |
| 6 Setting the fan                   | ▣▣▣▣ p. 11 - 151 |
| 7 Air-conditioning system on/off    | ▣▣▣▣ p. 11 - 153 |
| 8 Cooling, maximum                  | ▣▣▣▣ p. 11 - 154 |
| 9 Recirculated air                  | ▣▣▣▣ p. 11 - 151 |
| 10 Frost Guard <sup>1) 2)</sup>     |                  |
| 11 Setting the auxiliary heating    | ▣▣▣▣ p. 11 - 155 |
| 12 Heating on display               | ▣▣▣▣ p. 11 - 151 |

1) Additional equipment

2) ▣▣▣▣ *Separate operating manual*



**Set control lever  
characteristic  
curve menu**

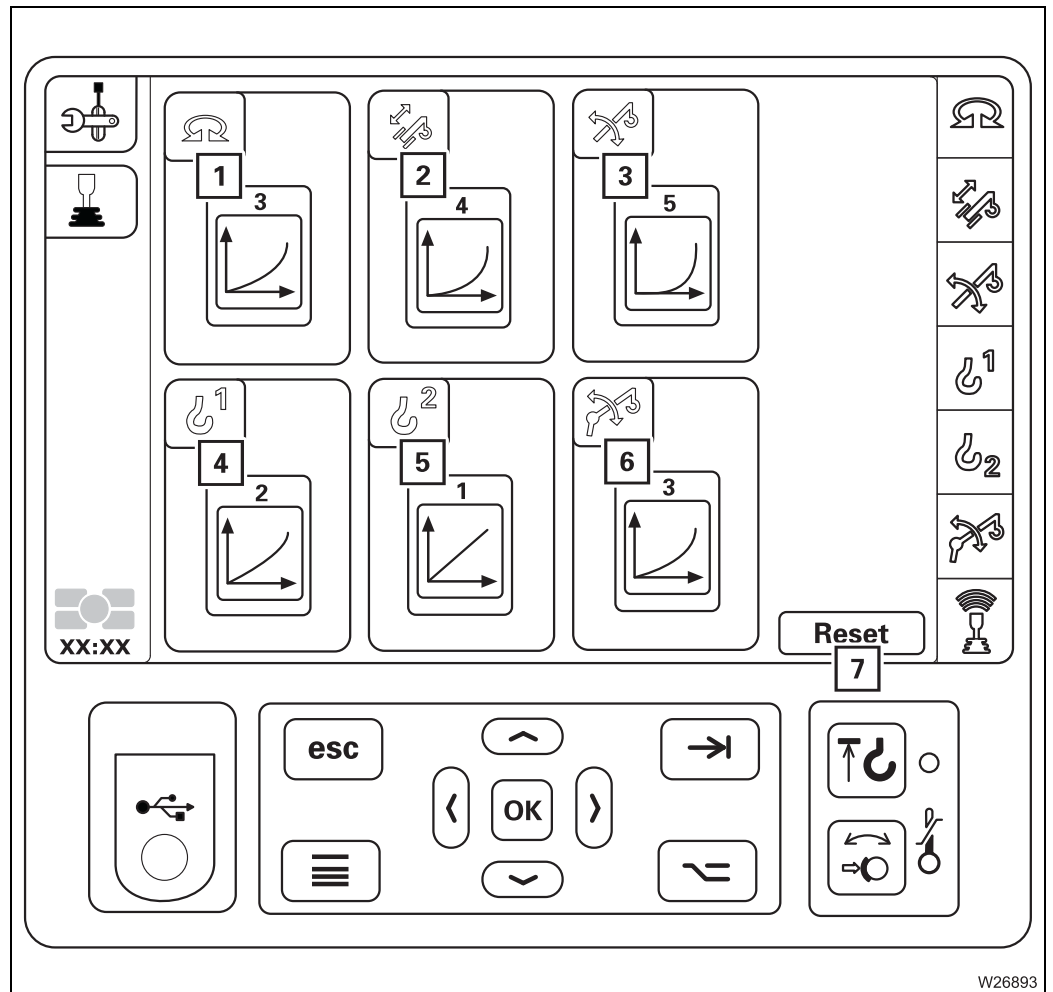

- 1 Characteristic curve slewing gear
- 2 Characteristic curve telescoping mechanism
- 3 Characteristic curve derricking gear
- 4 Characteristic curve main hoist
- 5 Auxiliary hoist<sup>1)</sup> characteristic curve
- 6 Lattice extension<sup>1)</sup> characteristic curve
- 7 Setting Reset characteristic curve

▶▶▶ p. 11 - 129

<sup>1)</sup> Additional equipment



## 9.1.20

### Menu-independent displays

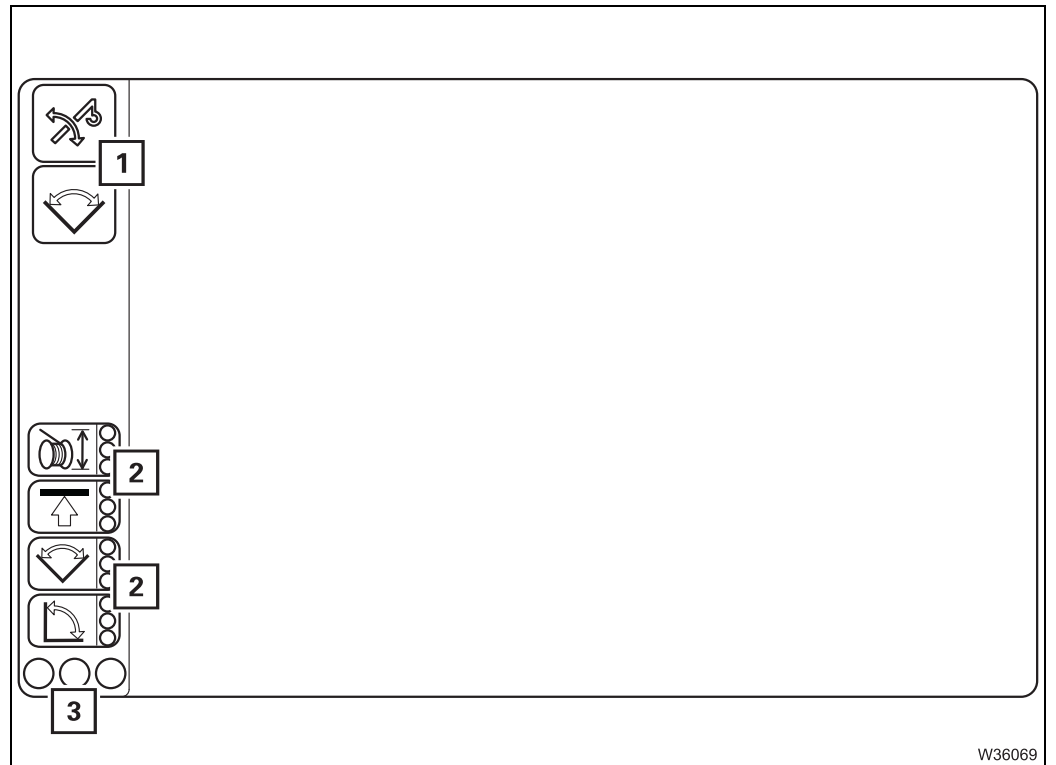

**1** Warning messages display

▣▣▣▣ p. 14 - 10

**2** Working range limiter displays

▣▣▣▣ p. 11 - 136

**3** RCL status display

▣▣▣▣ p. 11 - 51



**Opposite** means: on the side of the carrier opposite to the operator when looking at the control unit.

**Left and right** mean: to the left or the right of the control unit.

### Outriggers

- |   |                                                   |                  |
|---|---------------------------------------------------|------------------|
| 1 | Operating the left outriggers                     | ▶▶▶▶▶ p. 9 - 104 |
| 2 | Operating the left outriggers, opposite side      | ▶▶▶▶▶ p. 9 - 104 |
| 3 | Operating the right outriggers, opposite side     | ▶▶▶▶▶ p. 9 - 105 |
| 4 | Operating the right outriggers                    | ▶▶▶▶▶ p. 9 - 105 |
| 5 | Additional function F1                            |                  |
| 6 | Retracting all supporting cylinders               | ▶▶▶▶▶ p. 9 - 105 |
| 7 | Extending all supporting cylinders                | ▶▶▶▶▶ p. 9 - 105 |
| 8 | Pre-select high-speed mode                        | ▶▶▶▶▶ p. 9 - 103 |
| 9 | – Pre-select normal speed                         | ▶▶▶▶▶ p. 9 - 103 |
|   | – Automatic alignment – as additional function F1 | ▶▶▶▶▶ p. 9 - 105 |

### Outrigger pressure display

- |     |                                                 |                  |
|-----|-------------------------------------------------|------------------|
| 1.1 | Left-hand outrigger pressure display            | ▶▶▶▶▶ p. 9 - 109 |
| 2.1 | Left-hand outrigger pressure display, opposite  | ▶▶▶▶▶ p. 9 - 109 |
| 3.1 | Right-hand outrigger pressure display, opposite | ▶▶▶▶▶ p. 9 - 109 |
| 4.1 | Right-hand outrigger pressure display           | ▶▶▶▶▶ p. 9 - 109 |

### Inclination indicator

- |    |                                    |                  |
|----|------------------------------------|------------------|
| 10 | Switching over the measuring range | ▶▶▶▶▶ p. 9 - 108 |
| 11 | Display of current inclination     | ▶▶▶▶▶ p. 9 - 108 |



CLICK HERE TO **DOWNLOAD** THE COMPLETE MANUAL

- Thank you very much for reading the preview of the manual.
- You can download the complete manual from: [www.heydownloads.com](http://www.heydownloads.com) by clicking the link below



- Please note: If there is no response to CLICKING the link, please download this PDF first and then click on it.

CLICK HERE TO **DOWNLOAD** THE COMPLETE MANUAL

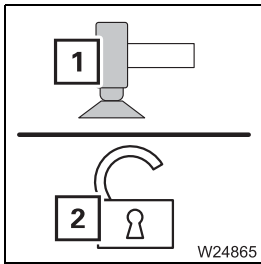

**In the operating area**

- For carrying out movements during rigging.  
The required element is marked, e.g. outrigger cylinder (1).
- For turning on/off and switching  
A symbol for a status is marked, e.g. symbol (2).

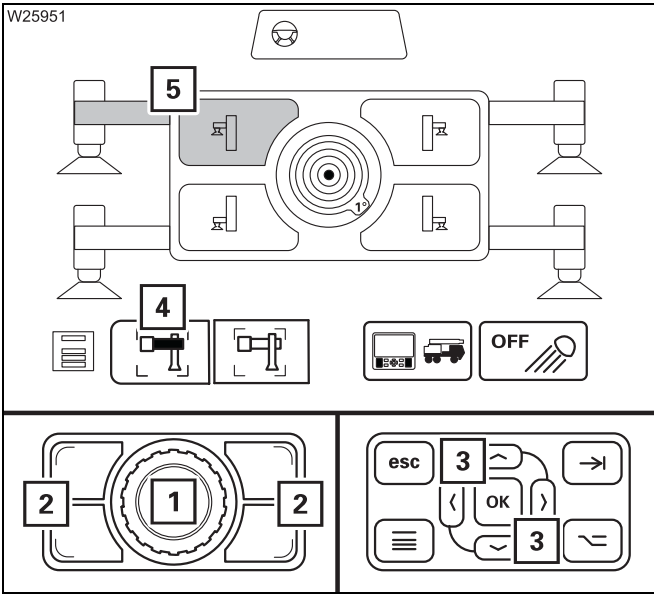

**Executing a movement**

- Select function  
**3 Press** or **1 Slewing**  
- The marked function (4) or (5) is selected.
- Move function  
**2 Press**  
- The selected function is carried out.

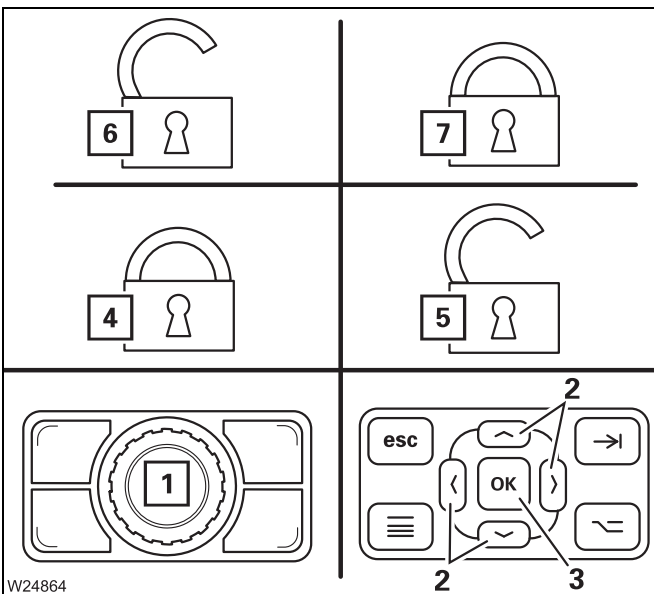

**Turning on/off and switching**

- Selecting status  
**2 Press** or **1 Slewing**  
- The marked state (4) or (6) is selected.
- Switch on state  
**1 Press** or **3 Press**  
- The selected state (5) or (7) is established.



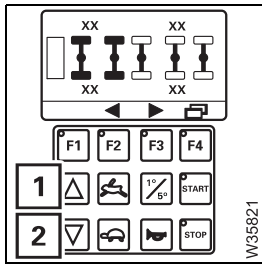

### Lifting/lowering wheels

The axle load on the pre-selected wheels lies in the permissible range.  
 The horn sounds when a button is pressed.

- 1 Raise:** Press the button – the selected axles are raised and the truck crane is lowered
- 2 Lower:** Press the button – the selected axles are lowered and the truck crane is raised

The movement stops after the button is released or the maximum permissible wheel load is exceeded.

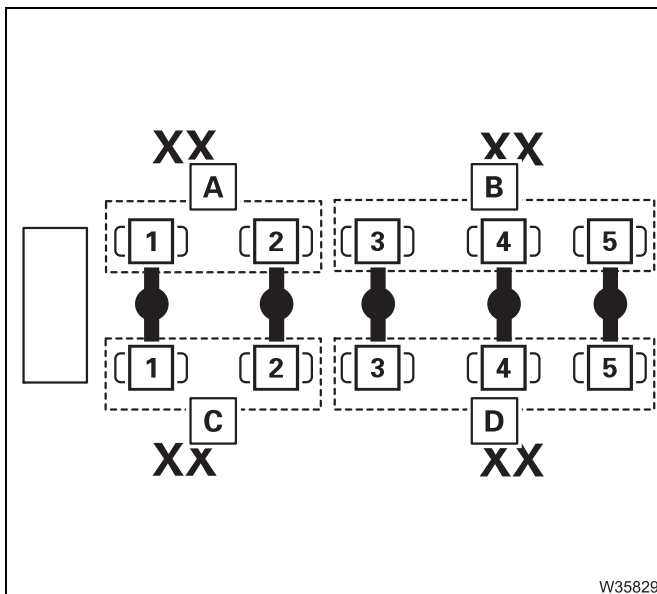

### Wheel load display

The displays (A) to (D) show the sum of the wheel loads for the associated wheels.

– **Opposite the operator side**

- A** Wheel load of the wheels A1 + A2
- B** Wheel load of the wheels B3 + B4 + B5

– **Operator's side**

- C** Wheel load of the wheels C1 + C2
- D** Wheel load of the wheels D3 + D4 + D5

The display is in tons or kilopounds, depending on the setting – (1 Kilopound = 1,000 lbs).

## CCS display

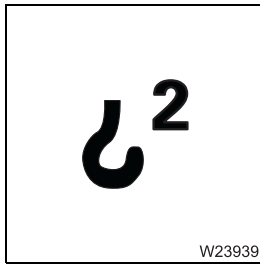

### Power units display

- **Green:** Auxiliary hoist on
- **Red:** Auxiliary hoist off

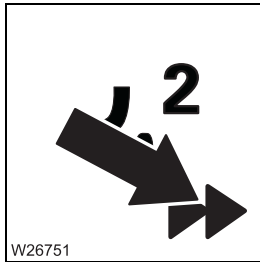

### High speed monitoring for the hoists

- **On:** High-speed mode on
- **Out:** High-speed mode off

▣▣▣▣▶ p. 11 - 113

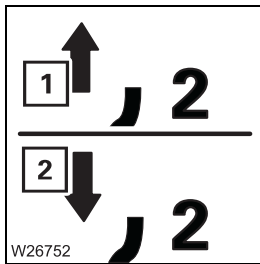

### Lift/lower the hoist display

- **Symbol (1):** Lifting
- **Symbol (2):** Lowering

▣▣▣▣▶ p. 11 - 113

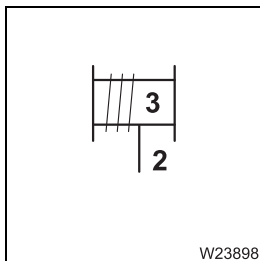

### Warning for lowering limit switch shutdown

- **Red:** Lowering limit switch triggered – auxiliary hoist stop
- **Grey:** Lowering limit switch not triggered

▣▣▣▣▶ p. 11 - 82

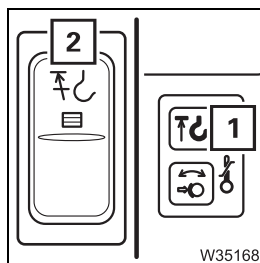

### Warning for lifting limit switch shutdown

#### Overriding the lifting limit switch

- 1 Short description with main hoist; ▣▣▣▣▶ p. 9 - 116
- 2 Short description with main hoist; ▣▣▣▣▶ p. 9 - 115

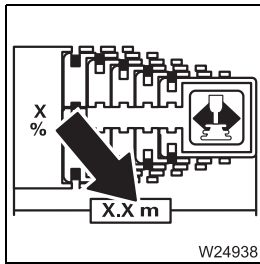

### Main boom length display

- **Display:** Current extended length of the main boom
- **Unit of measurement** Displayed depending on setting, mm (millimetres) or ft (feet)

:  
 p. 11 - 101

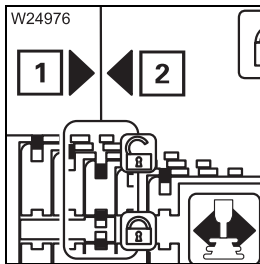

### Locking point display

- 1 Extend telescoping cylinder
- 2 Retract telescoping cylinder

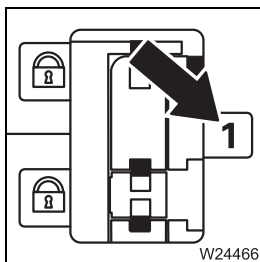

### Telescoping cylinder in the telescopic section display

Displayed telescopic section, e.g. telescopic section 1

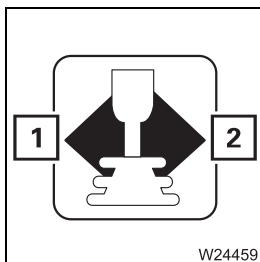

### Telescoping direction display

- 1 Start with *Retract*
- 2 Start with *Extend*

p. 11 - 110

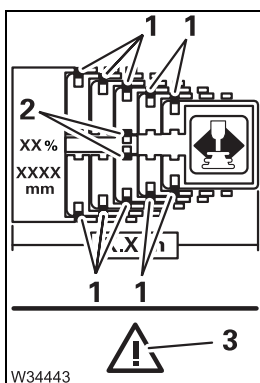

### Telescope diagram display

Current relation of the telescopic sections to each other – section of top view.

#### Locking pin

- 1 On the telescopic section
- 2 On the telescoping cylinder
- 3 Error

p. 11 - 102

#### Display 1 and 2

- **Green:** Locked
- **Yellow:** Intermediate position
- **Red:** Unlocked

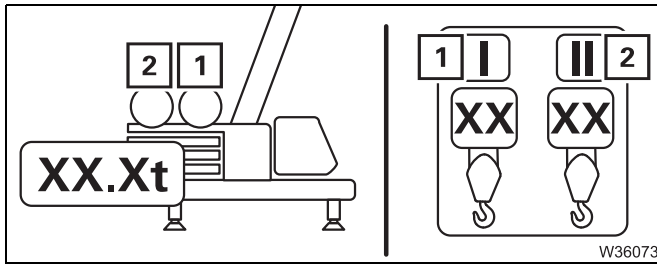

### Reeving input mode display

- 1 Main hoist
- 2 Auxiliary hoist

**Orange:** on

**Grey:** off

Enter rigging mode, p. 11 - 32

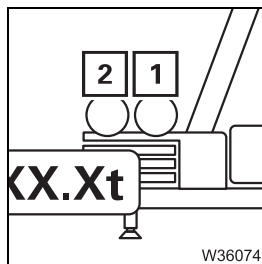

### Enter reeving

- 1 Main hoist  
In input mode – select and confirm current reeving
- 2 Auxiliary hoist – functions as with (1)

Enter rigging mode, p. 11 - 32

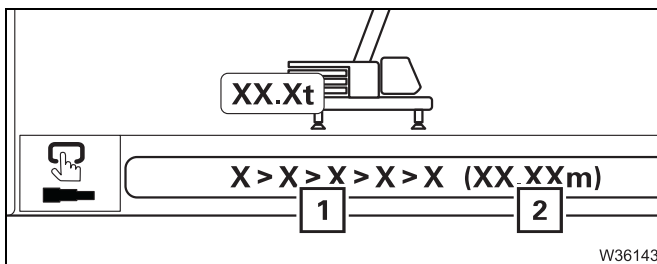

### Preselected telescoping display

- 1 Telescope status display in percentage (%)
- 2 Preselected main boom length (1) in metres (m) or in feet (ft)

Enter rigging mode, p. 11 - 32

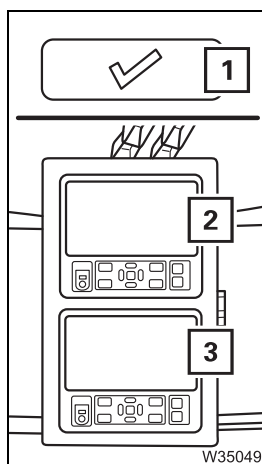

### Confirming the rigging mode

- 1 – **Orange:** Select and confirm
  - Rigging mode and preselected telescope status are adopted – lifting capacity table is confirmed
  - Display (2) – *Monitoring* menu on
  - Display (3) – *Start menu* on
- **Grey:** MAXbase only – no selection possible  
Measured outrigger width ≠ of required width

Enter rigging mode, p. 11 - 32



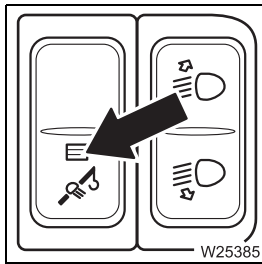

### Slewable spotlights on/off

- **Switch on:** Push down – lamp in the button on
- **Switch off:** Push up – lamp in the button off

▮▮▮▮ p. 11 - 130

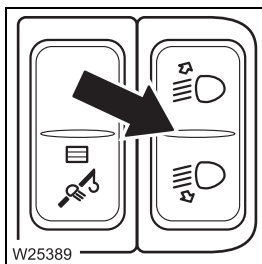

### Slew slewable spotlight

- **Down:** Push down
- **Up:** Push up

▮▮▮▮ p. 11 - 130

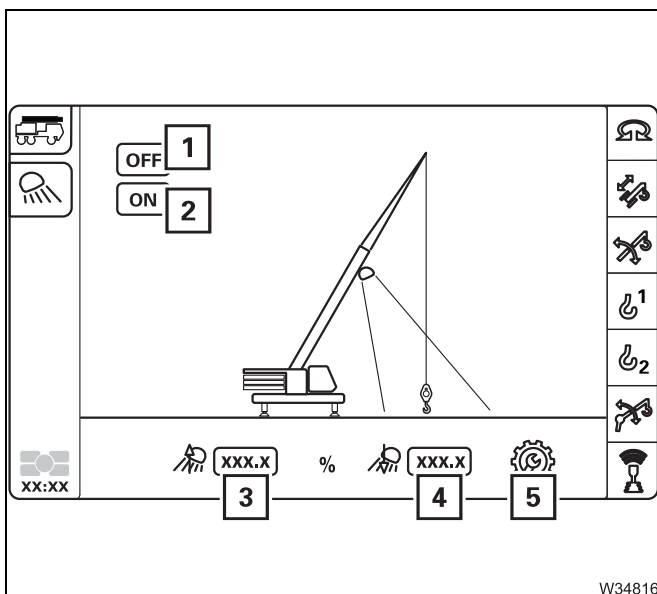

### Automatic spotlights

The spotlights are switched on.

- 1 Switch on – symbol (2) display
- 2 Switch off – symbol (1) display
- 3 Increase the slewing speed
- 4 Reduce the slewing speed
- 5 Submenu speed, opening/closing

▮▮▮▮ p. 11 - 130

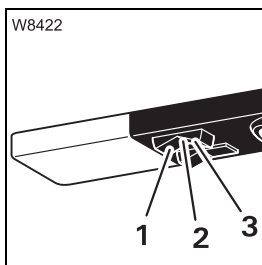

### Cab lighting

- 1 Always on
- 2 Always off
- 3 On/off via door contact



## 9.3

# Short description of the operating elements – driving from the crane cab

### 9.3.1

## Driving menu

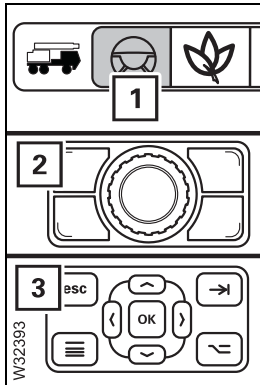

### Driving menu

- **Opening:** Select symbol (1) and confirm – menu is opened  
 The menu is also opened the first time the parking brake is released; p. 9 - 163
- **Applying:**
  - The parking brake must be engaged
  - Crane operation mode must be switched on

p. 13 - 19

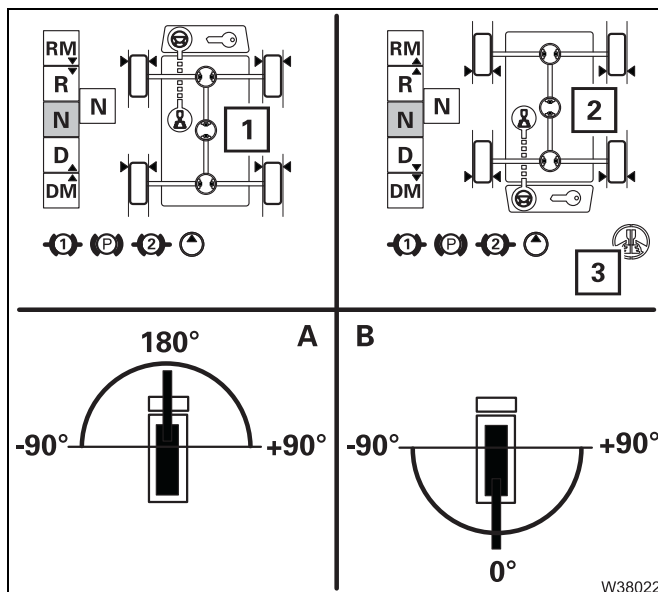

### Carrier display

- 1 Display in the front semi-circle (A)
- 2 Display in the rear semi-circle (B) – display of symbol (3)

p. 13 - 22





# 10

## Starting/switching off the engine – for crane operation

You must start the engine from the crane cab for crane operation. If the engine has been started from the carrier, then you must shut it down in the carrier and switch off the ignition before crane operation.

All the power units required for crane operation are only released when you start the engine from the crane cab.

The procedure depends on whether you:

- Start the (cold) engine for the first time in the day
- Start the engine from the crane cab;  p. 10 - 3,
- Start the engine with the hand-held control;  p. 10 - 10.

### 10.1

### When starting the engine for the first time in the day





#### Risk of crushing due to turning wheels

When you start the engine, no persons may be within the steering range of the 3rd and 5th axle lines. These axle lines can be briefly steered during the start of the engine; sometimes with five seconds delay.

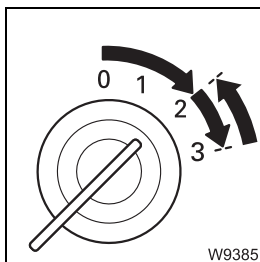
The first start of the day should always be made from the **driver's cab**, as all the displays for monitoring the engine can only be accessed there.



- Carry out all the required tasks and checks for starting the engine;  *CHECKLIST: Starting the engine*, p. 4 - 1.
- Start the engine from the driver's cab and perform all the necessary checks;  *Checks after starting the engine*, p. 4 - 15.

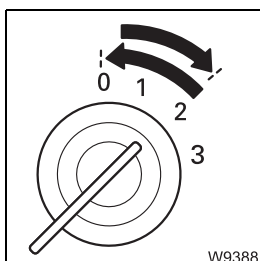

- Switch the engine off and switch off the ignition.



## 10.4

## Switch off the engine

### 10.4.1

### At the ignition lock and with hand-held control



#### Risk of accident by suspended loads

Never switch off the engine whilst a load is suspended. You must have the control levers at hand in order to intervene at any time. Always set down the load before you leave the crane cab.

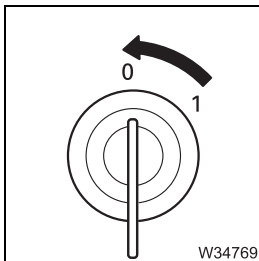

#### If the hand-held control is not connected:

- Turn the ignition key to position **0** – the engine will stop.  
The crane control is switched off.

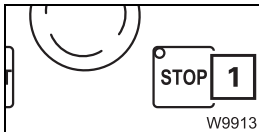

#### If the hand-held control is connected:

- Press the **(1)** button once – the engine will switch off.

In this case it is not possible to switch the engine off via the ignition lock.

### After switching off

Refer to the instructions in the respective sections for each type of stopping work;

▣▣▣▣ *In case of short work breaks, p. 11 - 149,*

▣▣▣▣ *In case of work breaks of more than 8 hours, p. 11 - 150.*

### 10.4.2

### With the idling button

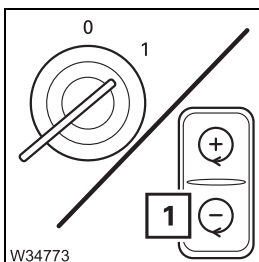

- Push the button **(1)** **down** and hold it there.
  - After about 3 seconds the idling speed will be at the standard value.
  - After a further about 3 seconds, the engine will switch off – the crane control remains switched on.  
The engine cannot be restarted until about 7 seconds have elapsed.

## Front control panel

You can adjust the height and inclination.

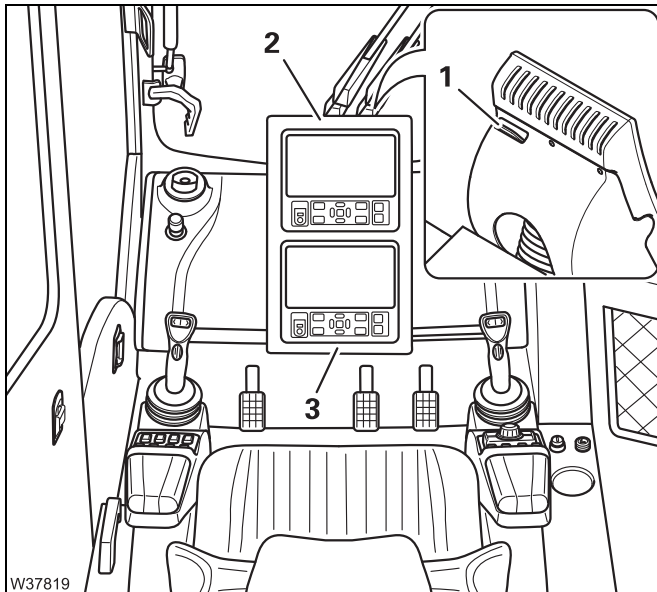

- Pull and hold the handle (1).
- Adjust the front panel to suit your requirements.
- Release the handle (1).

In addition, the inclination of the display can be adjusted:

- Press either (2) or (3).

### Switching off the houselock

- Check that the slewing gear is switched off, and switch it off if it is not;  
    ▶ *Switching off the slewing gear*, p. 11 - 17.

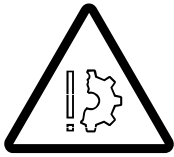

#### **Risk of damage during slewing!**

Always switch off the slewing gear before you operate the houselock. The system will be damaged if the superstructure is slewed during the locking procedure.

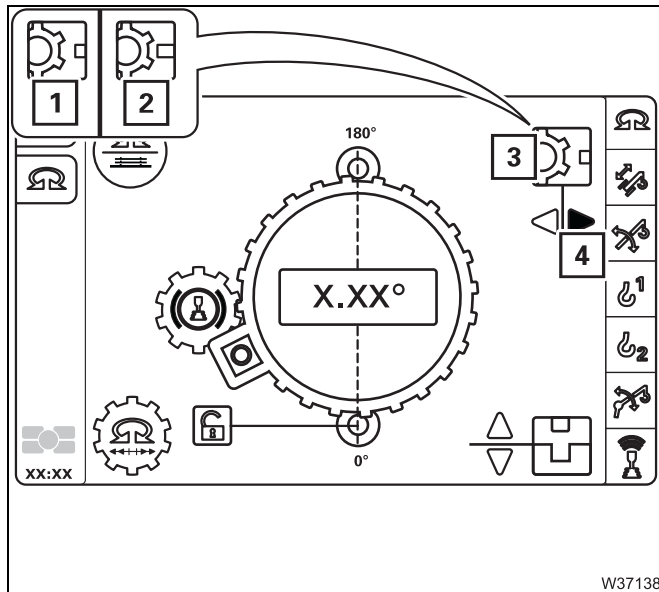

- Select the symbol (4).
- Press the button until the symbol (3) is displayed – *Houselock switched off*.

The display first shows the symbol (1), then symbol (2) in the intermediate position and then symbol (3) when the houselock is switched off.

## 11.4

### Operation of the rated capacity limiter

The rated capacity limiter is abbreviated to RCL (**R**ated-**C**apacity-**L**imiter) in these operating instructions.

If the truck crane's current rigging mode is registered properly, the RCL will prevent the permissible lifting capacity from being exceeded and the truck crane from being overloaded.



#### Risk of accidents due to an incorrectly set RCL

Ensure that the current rigging mode is correctly entered Before starting crane operation. An incorrect entry will give you a false sense of security. This may result in the truck crane overloading and causing an accident.

The current rigging mode is registered via

- Measurements,
- Acquired via manual entry.

Acquired via measurements	Acquired via manual entry
<ul style="list-style-type: none"> <li>– Main boom length</li> <li>– Main boom angle</li> <li>– Current load</li> <li>– Lattice extension inclination<sup>1)</sup></li> <li>– Outrigger span</li> </ul>	<ul style="list-style-type: none"> <li>– Counterweight</li> <li>– Length of lattice extension</li> <li>– Angle of the lattice extension<sup>2)</sup></li> <li>– Reeving</li> </ul>

<sup>1)</sup> Lattice extension – luffable

<sup>2)</sup> Lattice extension – inclinable

During the operation of the crane, a visual and acoustic early warning is issued before the load limit is reached and then the functions are shut down that would lead into the overload range.



#### Risk of accidents due to overridden or faulty RCL

The RCL must never be overridden.

It is prohibited to work if the RCL is switched off, overridden, out of service or faulty.



#### Danger of overturning in two-hook operation

The rated capacity limiter only ensures safety for single hook operation. Two-hook operation is not permitted.

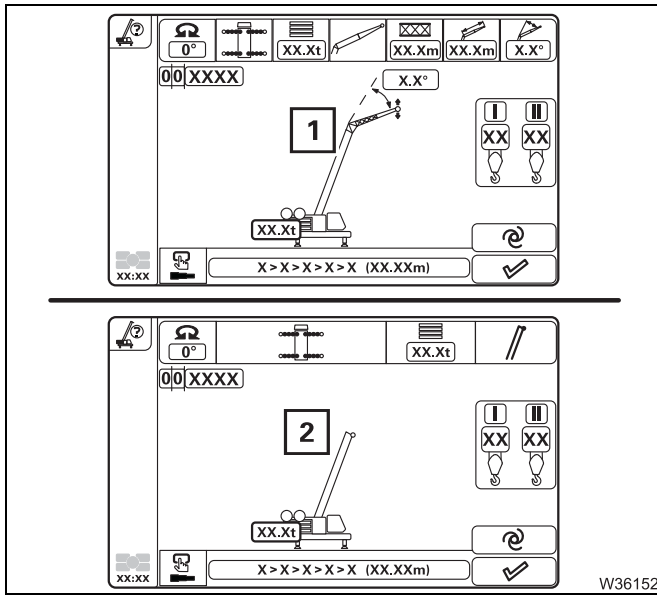

The confirmed boom system (1) or (2) is displayed.

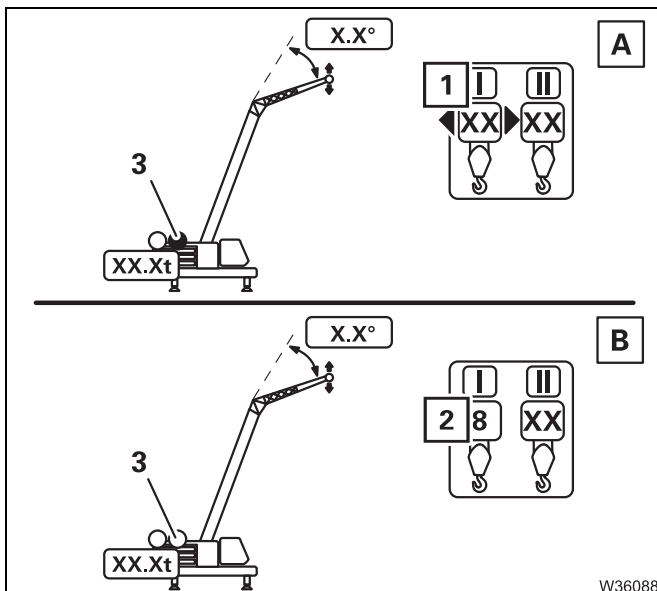

### Reeving

- (A) – Select and confirm the display for the hoist to be used for lifting the load, for example, display (1) for the main hoist – symbol (3) is orange.
- (B) – Select the currently rigged reeving (2), e.g. 8-fall.
- Confirm the selection and leave the display (1) – symbol (3) grey.



## 11.4.6

### Display during the crane operation

Various different information is shown on the *RCL* display and *CCS* display. This section describes only the displays that change during crane operation.

#### On the *RCL* display

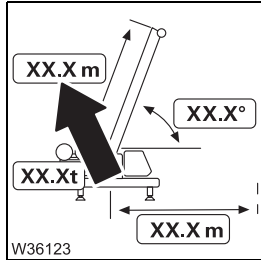

All displays are shown in the *Monitoring* menu.

#### Display of current main boom length

Shows the current main boom length in metres (m) or feet (ft).

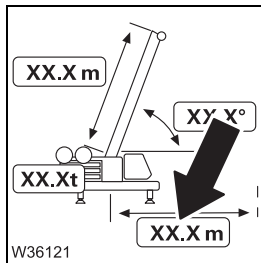

#### Current working radius display

Shows the current working radius = horizontal distance between the turntable axis and hook block axis in metres (m) or feet (ft).

The displayed value is calculated on the basis of the telescoping and the main boom or lattice extension angle.

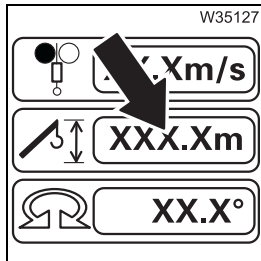

#### Current overall height display

Overall height = vertical distance between the lower edge of the outrigger pad and the highest point of the main boom or lattice extension.

The displayed value applies to fully extended outrigger cylinders on the largest outrigger span.

The value is displayed either in metres (m) or in feet (ft), depending on the setting.



## 11.4.9 Displaying the lifting capacity tables

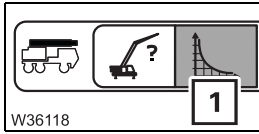

### Open menu

- Open the *Lifting capacity table* menu (1) on the CCS control unit.

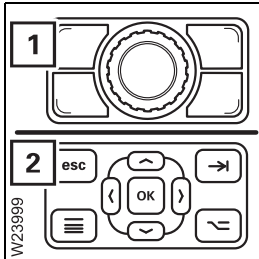

### Exiting the menu

- Press the button (1) or press the button (2) on the CCS control unit once – the Start menu opens.

### Slewing range type *Standard*

If the *MAXbase* slewing range type has been entered; ||||► p. 11 - 61.

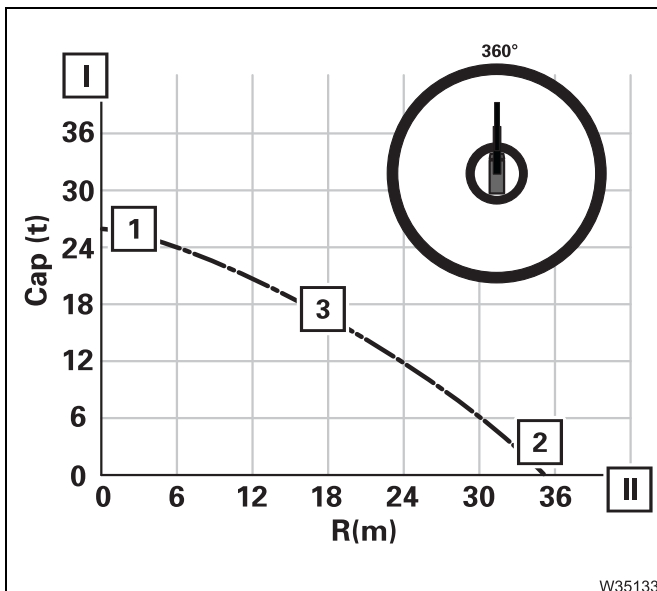

### Permissible working range display

The curve (3) applies to the displayed RCL code and the displayed telescope status.

- I Lifting capacity axis – in tons (t) or in kilopounds (klbs)
- II Working radius axis – in metres (m) or feet (ft)

The working range ends at the maximum possible working radius (2). Reduction of the working radius increases the enabled load along the curve (3) up to the maximum possible load (1).



## Display the data

You need the *CraneEvaluation* program in order to display the exported data. The installation program is located in the *CraneEvaluation* folder on the Owner's USB stick supplied.

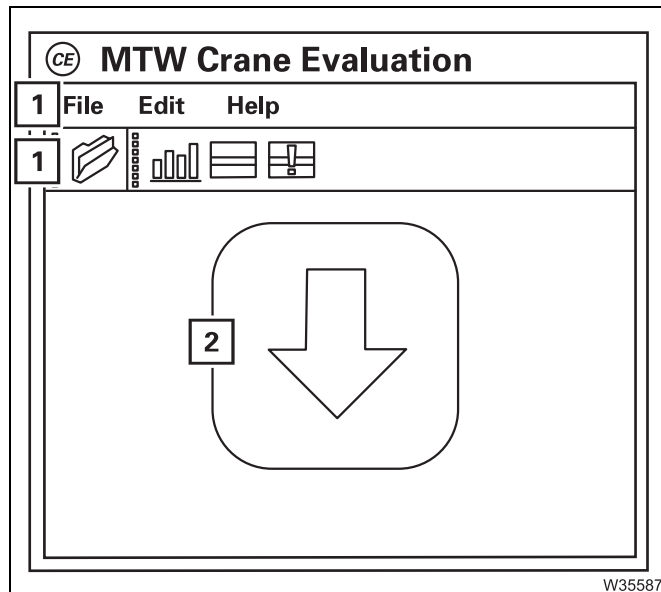

## Import data

- Start the *CraneEvaluation* program.
- Drag the file *xxx.mcd* onto the symbol (2) or open the file via a command (1).

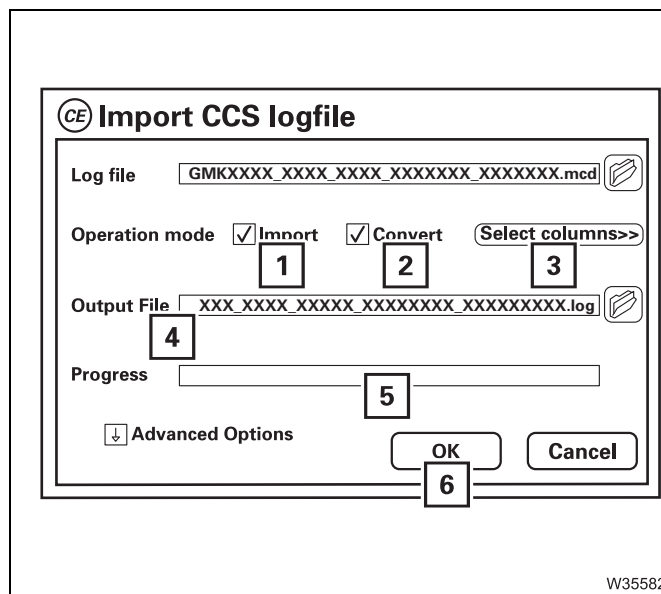

An Import window with various settings is displayed.

- 1 *Import* – the data is imported for display in the program.
  - 2 *Convert* – the data is saved in a log file that can be opened for example, with Excel.
  - 3 *Select columns* – with the default setting, all available data is imported. The menu allows individual selection.
  - 4 *Output File* – Storage location for the log file
- Confirm the selection via the symbol (6) – the display (5) shows the import progress.

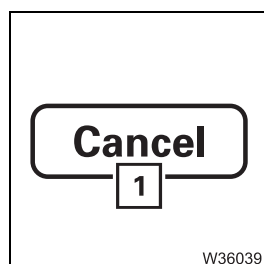

A graphical selection window opens. If you do not wish to select a graph, you can simply close the window – symbol (1); ➡ *Displaying tables*, p. 11 - 71.



### 11.5.3

## Auxiliary hoist



#### Risk of accidents when operating the auxiliary hoist

Read and observe all of the safety instructions in the section titled *Main hoist*, p. 11 - 75 before operating the auxiliary hoist.

All safety instructions for the operation of the main hoist also apply to the auxiliary hoist, along with the information in this section.



#### Risk of accidents due to a damaged hoist rope

If you reeve the auxiliary hoist rope in addition to the main hoist rope, make sure the hoist ropes do not rub against each other and that the auxiliary hoist rope does not touch the rotating flanged wheel of the main hoist during subsequent operation.

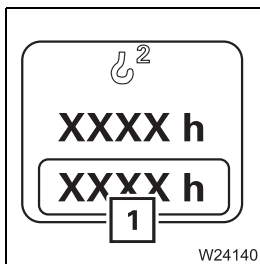

You can have the operating hours (1) of the hoist displayed; p. 11 - 133.

### Switching on the auxiliary hoist

After the ignition is switched on, all of the power units will be switched off and the lamps in the corresponding buttons will light up only dimly.

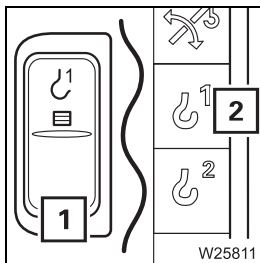

- Check whether the main hoist is switched off and therefore secured against unintentional operation.
  - The lamp in button (1) should light up only dimly.
  - Symbol (2) must be **red**.

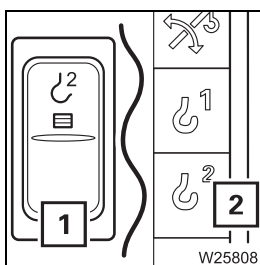

- Press the button (1) once.
  - The lamp in button (1) will light up brightly.
  - Symbol (2) is **green** when the auxiliary hoist is switched on.



## 11.5.6

### Telescoping mechanism

A telescoping process requires locking and unlocking processes in the main boom. You can telescope the main boom in different ways.

– **manual telescoping**

For manual telescoping, you must initiate all locking and unlocking processes at the right time.

– **telescoping with semi-automaton**

When telescoping with semi-automation, you enter a telescoping value and CCS controls all the locking and unlocking processes automatically. You may then need to manually telescope to an intermediate length.

– **telescoping with pre-selection**

When telescoping with pre-selection, you can enter several parameters for lifting the load and the CCS suggests corresponding telescoping values that you can use as the starting point for semi-automatic teleautomation. Telescoping with pre-selection has no independently selectable menu. The parameters are entered when entering the rigging mode at the RCL and the telescope status displays are in the RCL *Monitoring* menu.

This is operated using the control lever. The control unit *CCS still forms part of the operation*. Here you initiate processes, receive feedback and can monitor the telescoping process.

The *CCS* display shows various sectional views of the main boom. To make you familiar with these representations more quickly, the following section begins with an overview of the telescoping mechanism and a telescoping process.



The distance between the hook block and the boom head changes during telescoping. Ensure that the hook block does not trigger the lifting limit switch or touch the ground.

- Additionally carry out the following movements
  - Lower hoist when extending and
  - the Raise hoist movement when retracting.

The control lever movements for telescoping vary depending on the configuration.

– **With telescoping assigned to the right-hand lever**

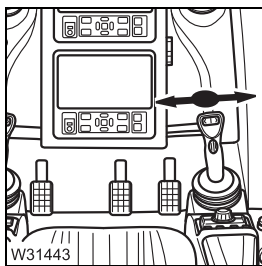

- To extend:** • Push the control lever to the right.
- To retract:** • Push the control lever to the left.

– **With telescoping assigned to the left-hand lever**

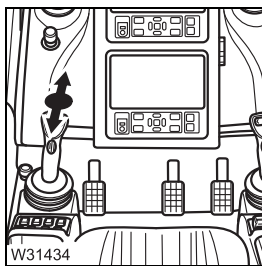

- To extend:** • Push the control lever forwards.
- To retract:** • Pull the control lever backwards.

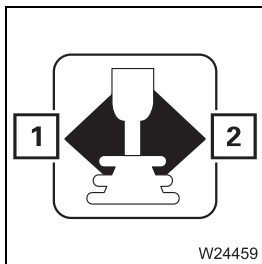

Telescoping will only start if arrow (1) or (2) for the selected telescoping direction is **green**.

You can regulate the speed by moving the control lever and changing the engine speed with the accelerator.



With certain telescoping states, the RCL will switch telescoping off, for example, when you leave the telescoping lengths or when the working range limit has been reached;  *RCL shutdown*, p. 11 - 57.



### Locking the telescopic section

Every telescopic section can be locked at the fixed lengths – fixed lengths;  
 p. 11 - 95.

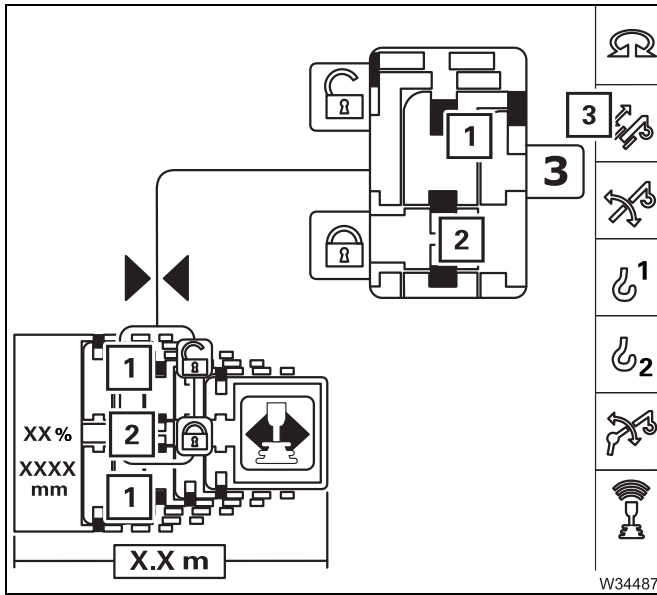

### Prerequisites

- Telescoping mechanism on – symbol (3) green
- Telescopic section unlocked – symbol (1) red
- Telescoping cylinder locked – symbol (2) green.

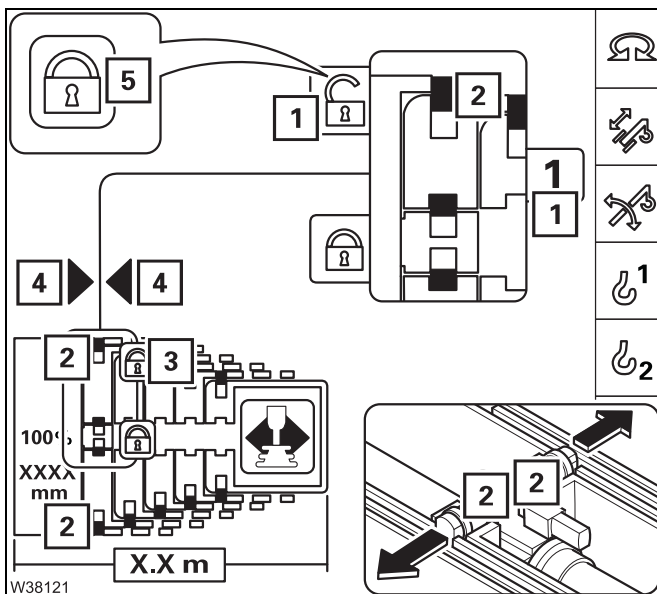

### Locking

- Telescope to the desired fixed length, e. g. telescopic section (1) 1 to 100%.
- If the symbol (4) is displayed, the telescopic section must be locked.
- Select and confirm the symbol (3). The locking pins (2) extend.
    - **Yellow:** Intermediate position
    - **Green:** Locked – symbol (5) displayed



## Braking the slewing movement



You may only brake the slewing movement with the slewing gear brake.

### Risk of the main boom buckling.

On no account switch the slewing gear off to brake it; only switch the slewing gear off when the superstructure has stopped rotating.

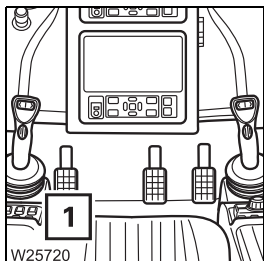

### With the *Brake pedal* function switched on

- Depress the brake pedal (1) Do not brake to such a degree that the load starts swinging.

If you only move the control lever to initial position, the slewing movement will slowly run down.

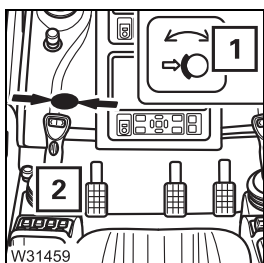

### With the *Control lever* function switched on

- Move the control lever (2) towards its initial position – the slewing movement will be stopped.

At the initial position, the slewing movement will be stopped. At the same time the slewing gear brake will be applied, and lamp (1) will light up.

## Slewing gear freewheel

The slewing gear freewheel is required if the slewing gear needs to be slewed by means of external forces, for example, when operating with two cranes.

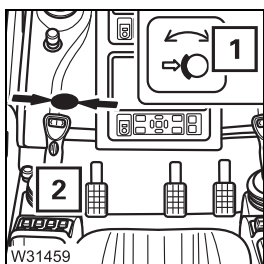

### With the *Brake pedal* function switched on

- Switch on the slewing gear.  
The slewing gear brake is released – lamp (1) lights up.
- Shift the control lever (2) to its initial position.

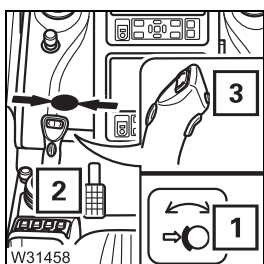

### With the *Control lever* function switched on

- Switch on the slewing gear.
- Shift the control lever (2) to its initial position.
- Press the button (3).  
The slewing gear brake is released – lamp (1) lights up.



## 11.6.7 Setting the characteristic curves for the control levers

The control lever characteristic curve determines how high the power unit speed should be for a particular control lever movement.

You can assign different control lever characteristic curves to the power units.

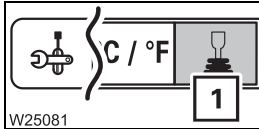

- Open the *Settings (1)* menu.

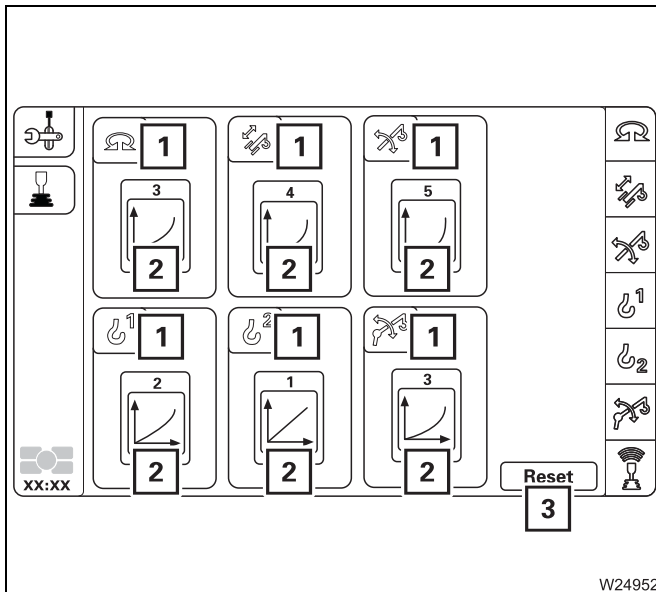

The symbols (2) show the set characteristic curves of the power units (1).

- Select the power unit for which you would like to change the characteristic curve.
- Set the desired characteristic curve.

Select and confirm symbol (3) to reset all power units to characteristic curve 1.

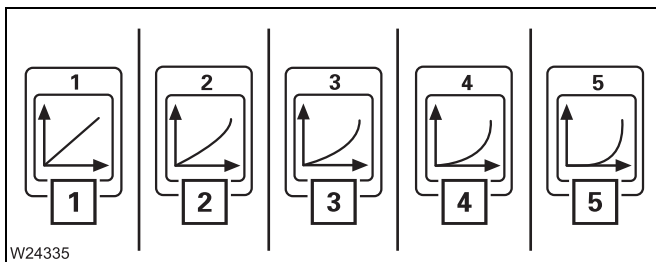

There are five characteristic curves:

The higher the number of the characteristic curve (1) to (5), the further the control lever must be moved to get a clear increase in speed.

With characteristic curve (5), you can work particularly sensitively with the control lever.

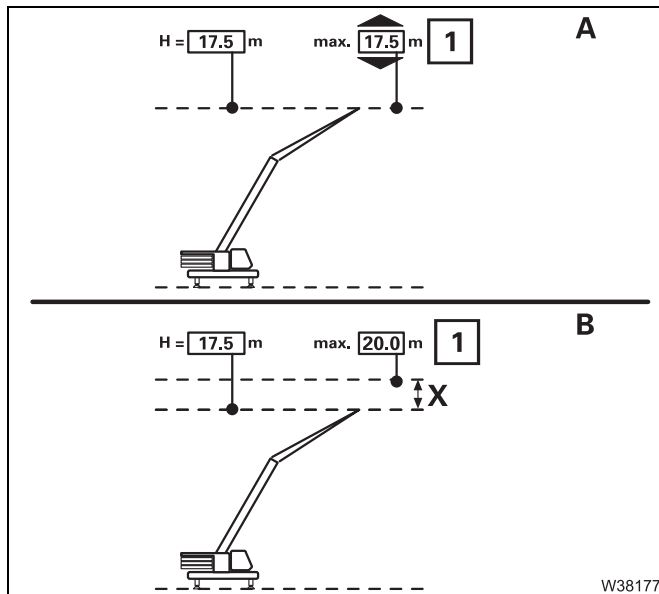

### Entering limit values manually

- (A) – Select and confirm the display (1).
- (B) – Enter the limit value, for example, 20.0 m and confirm the input.

Display (1) shows the newly inputted limit value.

The distance (X) shows the current distance to the shutdown range.

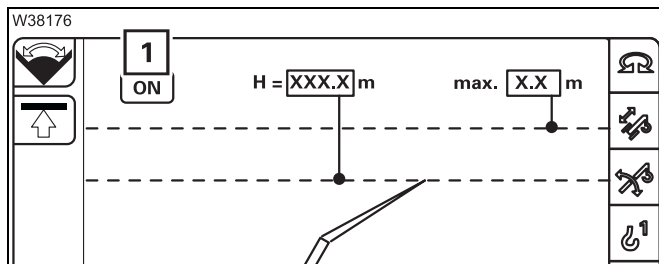

### Switch on monitoring

- Select and confirm the symbol (1).  
The *Overall height* monitoring is switched on.



The movement towards the shutdown limit is continually reduced until reaching a standstill. The current limitation is displayed;

- ▮▮▮▮ On the RCL display, p. 11 - 136,
- ▮▮▮▮ On the CCS display, p. 11 - 53.

## 11.8

## Work break

### 11.8.1

### In case of short work breaks



#### Risk of accident by suspended loads

Never switch off the engine whilst a load is suspended. You must have the control levers at hand in order to intervene at any time.

Always set down the load before you leave the crane cab.

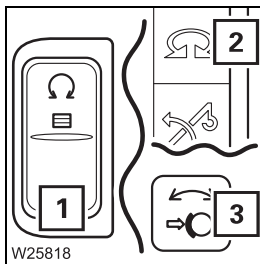

- Switch off the slewing gear.
  - The lamp in the button (1) must be dimly lit.
  - Then symbol (2) turns **red** – slewing gear switched off.
  - Lamp (3) must light up – slewing gear brake applied.

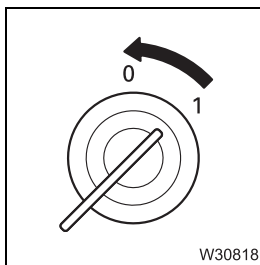

Switch the engine off, turn the ignition key to position **0** and remove it.

Ensure that no unauthorised persons can operate the truck crane;

➡ *To secure the truck crane, p. 11 - 150.*

# 12

## Rigging work

If the truck crane on the site has already been rigged, proceed according to the *CHECKLIST: Checks before operating the crane*, p. 11 - 1.

### 12.1

## Rigging work checklists for crane operation with the main boom



This checklist is not a complete operating manual. There are accompanying operating instructions which are indicated by cross-references.

**Observe the warnings and safety instructions there.**

### 12.1.1

## CHECKLIST: Rigging

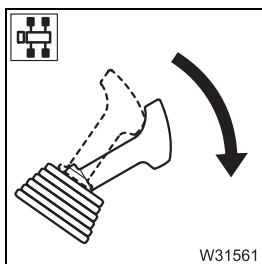

1. Choose a suitable site; *Choice of a suitable positioning site*, p. 12 - 11.

2. Check that the parking brake is engaged – if necessary, engage the parking brake.

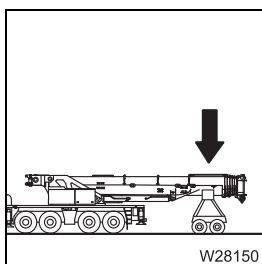

3. **If the main boom is resting on a dolly:**

- Switch off the boom floating position; p. 12 - 19
- Switch off the slewing gear freewheel; p. 12 - 20
- If necessary, switch off boom pre-tensioning; p. 12 - 21.







The following points only apply to rigging in *Free on wheels* working position. Continue the checklist at **point 8**. when rigging the truck crane on outriggers.



## 12.2

### Choice of a suitable positioning site

Choose the position of your truck crane at the site with care. Observe the following aspects:

- Check that the ground has sufficient load bearing capacity. You may need to enlarge the load-bearing area;  p. 12 - 11.
- Observe the required safe distances to slopes and pits;  p. 12 - 14.
- If there is a danger of it becoming charged with static electricity, earth the truck crane;  p. 12 - 15.
- Keep a safe distance to electrical cables;  p. 12 - 15.
- Choose the site such that the unevenness of the ground can be compensated for by adjusting the outrigger cylinders. Maximum hoist of the outrigger cylinders;  p. 1 - 19.
- Choose a location where it is possible to keep the working radius to a minimum and where no obstacles are within the slewing range of the crane.

### 12.2.1

#### Determining the required load-bearing area

The stability of the truck crane depends in the first instance on the load bearing capacity of the ground. The load bearing capacity of the ground and the occurring outrigger pressure determine the load-bearing area required for the operation.

$$\text{Load-bearing area (m}^2\text{)} = \frac{\text{Outrigger pressure (t)}}{\text{Load bearing capacity of the ground (} \frac{\text{t}}{\text{m}^2}\text{)}}$$

#### Outrigger pressure

- Determine the outrigger pressure for the operation planned using the *Outrigger pressure table*.



### 12.3.3

## Switching off boom pre-tensioning

You must switch off the boom pre-tensioning before you raise the main boom off the dolly.

To switch off boom pre-tensioning, you must bring the valves I to IV into the required positions, which will empty the pressure accumulator.

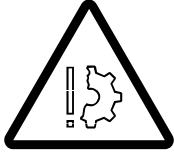

### Danger of the hydraulic oil overheating

Always switch the valve IV (▣▶ p. 12 - 19) over (lever in horizontal position) before operating the crane.

This prevents the pressure in the hydraulic circuit rising and the hydraulic oil exceeding the permissible temperature of 80 °C (176 °F).

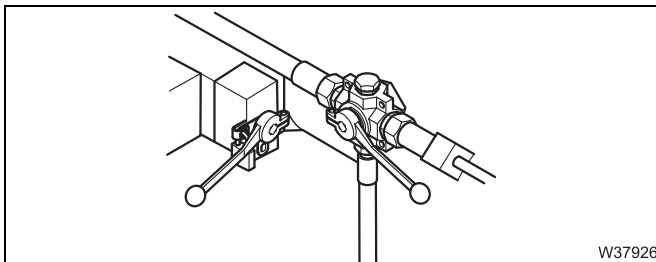

- Switch off the boom floating position; ▣▶ p. 12 - 19.

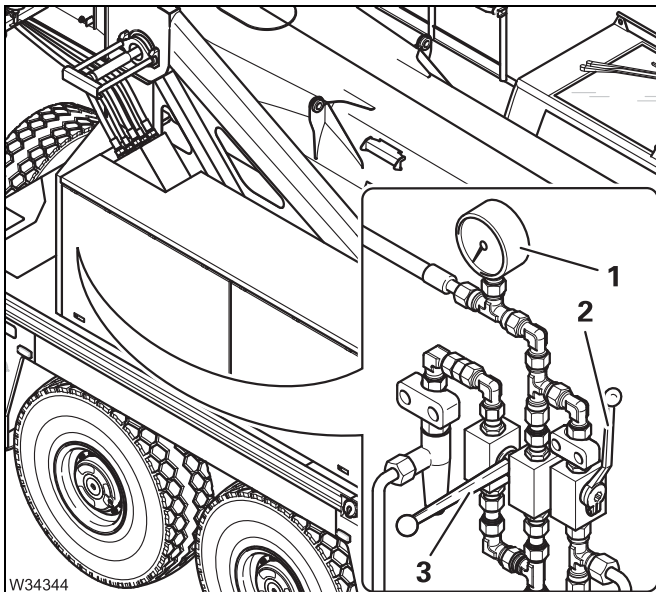

The valves II and III are under the pressure gauge (1).

- Open valve II – the lever (2) is vertical.

The pressure accumulator is emptied. The pressure on the pressure gauge (1) must drop to 0 bar (0 psi).

The valve III stays closed – lever (3) is horizontal.

## 12.6

### Slewing range – only with the Standard slewing range type

The information in this section applies only to the *Standard* slewing range type. If you wish to operate the truck crane using the *MAXbase* slewing range type;  p. 12 - 33.

All permissible outrigger spans are symmetrical. All outrigger beams are extended and all outrigger beams are extended to the same outrigger span;  *Enabled outrigger spans*, p. 12 - 32.

### 12.6.1

#### Representation in the lifting capacity tables

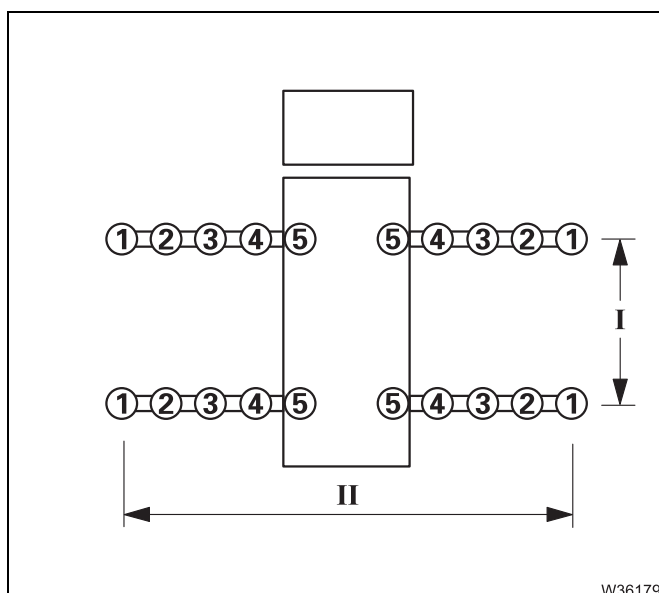

The outrigger span is always specified in this form in the *Lifting capacity table*.

**Outrigger length xxxx – outrigger width yyyyy**

#### – Outrigger length

The outrigger length (I) has a fixed value of 8.030 m (26.3 ft) and never changes for a fully supported truck crane.

#### – Outrigger width

The outrigger span relates to the overall width (II). There are five outrigger spans (1) to (5).

## 12.8

## Outrigger operation



### Danger of crushing by extending outrigger beams.

You may only activate the outriggers if you yourself or a banksman with whom you are in visual contact have an unobstructed view of their movements.

### 12.8.1

### CHECKLIST: Extending the outriggers



This checklist is not a complete operating manual. There are accompanying operating instructions which are indicated by cross-references.

**Observe the warnings and safety instructions specified here!**

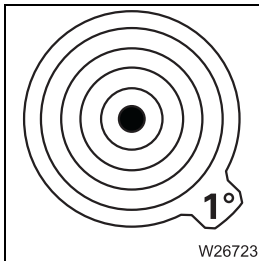

1. Level the truck crane with the level adjustment system and lower it as far as possible; p. 5 - 53.

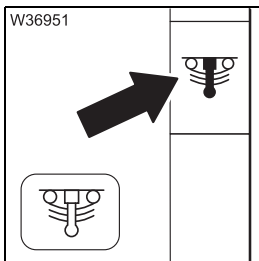

2. Deactivate (Lock) the suspension – symbol **red** (suspension off); p. 5 - 17.

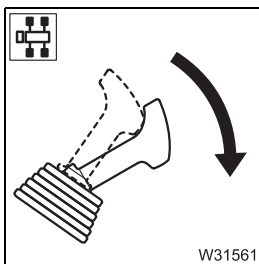

3. Engage parking brake; p. 5 - 46.

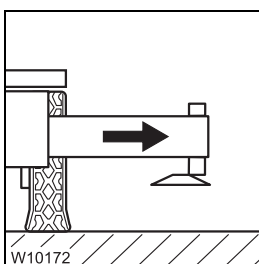

4. Extend all outrigger beams to the required span;
  - For the *Standard* slewing range type; p. 12 - 32
  - For the *MAXbase* slewing range type; p. 12 - 36
  - Setting the outrigger spans*, p. 12 - 46
  - Extending/retracting outrigger beams*, p. 12 - 49.



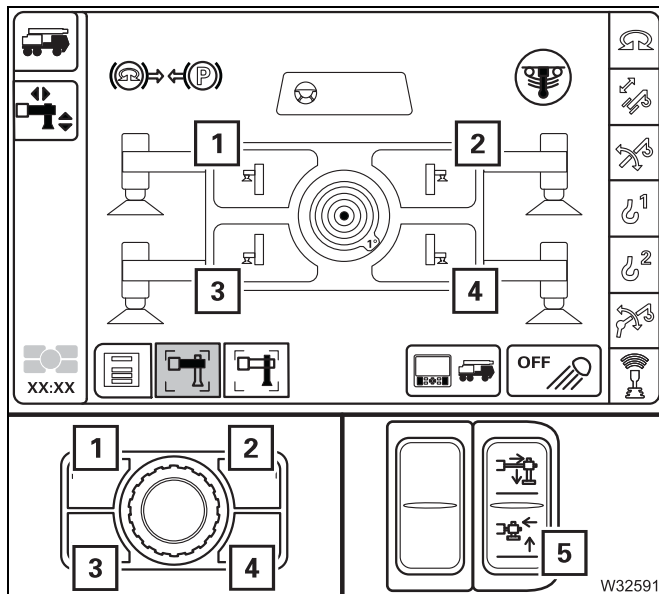

### Retracting

- Press the button for the desired outrigger beam.
  - 1 Front left
  - 2 Front right
  - 3 Rear left
  - 4 Rear right
- Press the button (5) in at the bottom – the selected outrigger beam retracts.

### From the control units

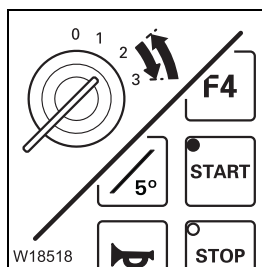

### Starting the engine

- Start the engine from the driver's cab; ||||► p. 4 - 13.
- You can also start the engine from the control units; ||||► p. 12 - 27.

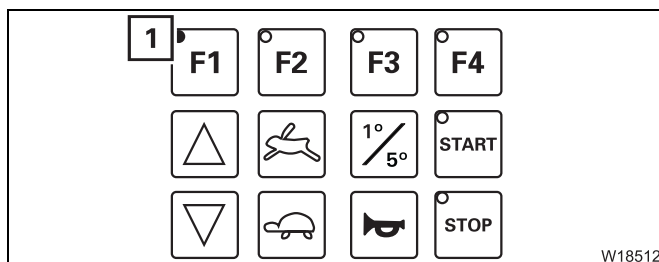

### Switching on the lighting

- Only the lamp (1) lights up after opening the door.
- Press any button.  
The lights are switched on.



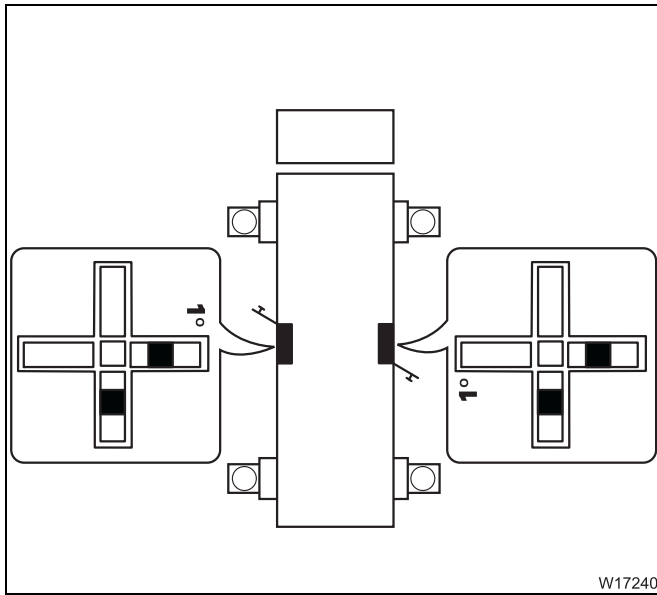

– *Outrigger* control units

The assignment to the carrier corresponds to the top view.

Due to the position of the control units, the displays on both sides differ.

In this example, the carrier would be standing higher to the rear on the right hand side.

**Prerequisites**

The following prerequisites apply to manual and automatic alignment.

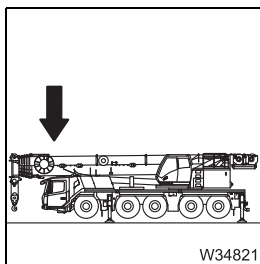

The main boom must be resting in the boom rest.

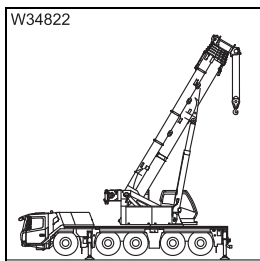

Or

- The main boom must be raised **and**
- the load must have been set down **and**
- the superstructure must be in the 0° or 180° position.



**Risk of overloading the main boom**

Always slew the superstructure to the 0° or 180° position and set down the load before levelling the truck crane.

In other positions, the deformation of the carrier will create incorrect results for the inclination and the truck crane will be at an angle. This could cause the boom to become overloaded during crane operation.



## 12.9

### Rigging/unrigging the counterweight

For driving, parts of the counterweight must be set down on the counterweight platform, installed on the turntable or removed, depending on the driving mode;  *Driving modes*, p. 6 - 1

#### 12.9.1

#### Information on rigging

Rigging the counterweight is a challenging task. Only experienced personnel who are familiar with the valid accident prevention regulations are authorised to sling counterweight sections and instruct the crane operator.

When the engine is running for crane operation, the rigging personnel may only climb on the truck crane when the slewing gear is switched off and the slewing gear brake is applied.

The crane operator and rigging personnel must maintain visual contact during the rigging process.

The rigging process for a single counterweight section is described. Proceed in the same manner when rigging other counterweight sections or blocks.

#### When rigging

##### As the crane operator

- Lift the counterweight section onto the counterweight platform as described in the section *Assembling counterweight combination*.
- Now inform the rigging personnel that they can climb on the truck crane.

##### As the rigging personnel

- Do not climb on the truck crane until permitted by the crane operator.
- Position the counterweight if necessary.



### Setting down the 2.3 t base plate

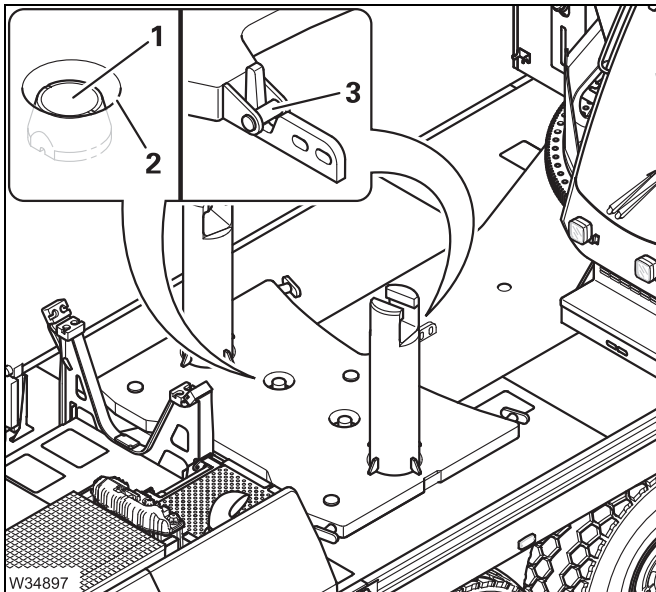

#### With versions 1, 2 and 3

Only the 2.3 t base plate may be set down directly on the counterweight platform. You can use the holder (3) to position the 2.3 t base plate centrally on the carrier.

- Position the 2.3 t base plate in such a way that the holders (1) grip into the recesses (2).

For larger counterweight combinations, now set additional counterweight sections onto the 2.3 t base plate.



#### Risk of damage to the counterweight

Always position the 4.6 t section at the top. This prevents the lifting cylinders and counterweight being damaged while rigging.

### Setting down the top counterweight section

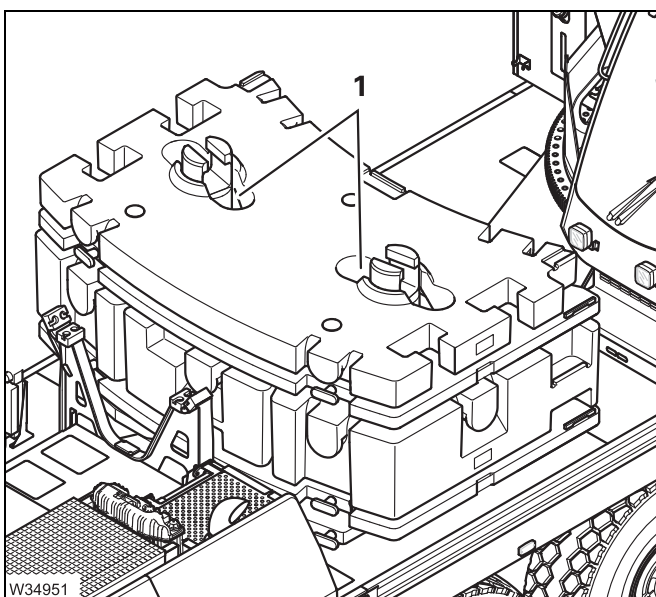

#### With versions 1, 2 and 3

Always place a plate with cutouts (1) as the uppermost counterweight section.

Only then can the lifting cylinder be rotated into the 2.3 t base plate.



Counterweight combination in t (lbs)	Counterweight sections in t (lbs)							
	2.3 (5,071) [1]	2.3 (5,071) [2]	4.6 (10,142) 2 x [3] <sup>1)</sup>	2.3 (5,071) [4]	4.6 (10,142) [5]	9.2 (20,283) [6] <sup>2)</sup>	1.0 (2,205) [7] <sup>3)</sup>	6.8 (14,991) [9]
1.0 (2,205)	-	-	-	-	-	-	●	-
3.3 (7,275)	●	-	-	-	-	-	●	-
5.6 (12,346)	●	●	-	-	-	-	●	-
7.9 (17,417)	●	● <sup>4)</sup>	-	●	-	-	●	-
	●	-	-	-	●	-	●	-
10.2 (22,487)	●	● <sup>4)</sup>	-	-	●	-	●	-
	-	-	-	-	-	●	●	-
12.5 (27,558)	●	● <sup>4)</sup>	-	●	●	-	●	-
	●	-	-	-	-	●	●	-
14.8 (32,628)	●	●	●	-	-	-	●	-
	●	●	-	-	-	●	●	-
17.1 (37,699)	●	●	●	●	-	-	●	-
	●	● <sup>4)</sup>	-	●	-	●	●	-
19.4 (42,770)	●	●	●	-	●	-	●	-
	●	● <sup>4)</sup>	-	-	●	●	●	-

- 1) Must always lie on [2].
- 2) Must be installed on the turntable.
- 3) Or use [8].
- 4) Must always lie on top.



Counterweight combination in t (lbs)	Counterweight sections in t (lbs)							
	2.3 (5,071)	2.3 (5,071)	4.6 (10,142)	4.6 (10,142)	2.3 (5,071)	2.3 (5,071)	1.0 (2,205)	6.8 (14,991)
	1	2	3	4	5	6	7 <sup>1)</sup>	9
24.0 (52,911)	●	1 x	3 x	●	–	–	●	–
	●	2 x	3 x <sup>2)</sup>	–	● <sup>5)</sup>	–	●	–
	●	–	3 x	●	● <sup>5)</sup>	–	●	–
	●	2 x	3 x <sup>2)</sup>	–	–	● <sup>7)</sup>	●	–
	●	–	3 x	●	–	● <sup>7)</sup>	●	–
	●	1 x	3 x <sup>2)</sup>	–	● <sup>6)</sup>	● <sup>7)</sup>	●	–
26.3 (57,981)	●	2 x	3 x	●	–	–	●	–
	●	1 x	3 x	●	● <sup>5)</sup>	–	●	–
	●	1 x	3 x	●	–	● <sup>7)</sup>	●	–
	●	2 x	3 x <sup>2)</sup>	–	● <sup>6)</sup>	● <sup>7)</sup>	●	–
	●	–	3 x	●	● <sup>6)</sup>	● <sup>7)</sup>	●	–
30.9 (68,123)	●	2 x	3 x	● <sup>8)</sup>	● <sup>6)</sup>	● <sup>7)</sup>	●	–
44.5 (98,106)	●	2 x	3 x	● <sup>8)</sup>	● <sup>6)</sup>	● <sup>7)</sup>	●	●

1) Or use 8

2) 1 x 3 can be replaced with 4

3) Must be installed on the turntable

4) 5 Must be installed under 6

5) Must always lie on top

6) 5 Must lie on top, or lie under 6 or installed under 6

7) 6 Must lie on top or be installed on the turntable

8) 4 Must lie on top, or lie under 5

## 12.9.10

### Setting down counterweight for driving

Which parts of the counterweight sections can be transported on the turntable and counterweight platform when driving the truck crane depends on the driving mode of the truck crane;  *Driving modes*, p. 6 - 1.

With all versions, the 1 t compensation weight or the auxiliary hoist is mounted on the turntable.

#### Versions 1 and 3

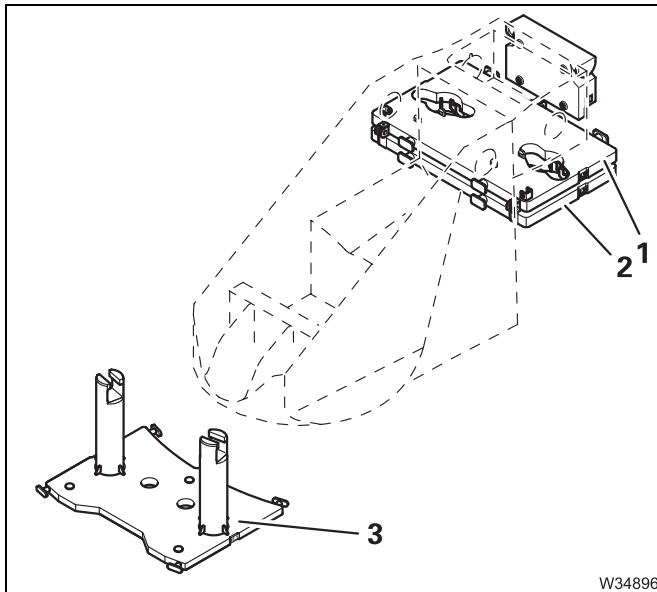

#### For driving with axle loads up to 12 t

- The 2.3 t plates (1) and (2) are mounted on the turntable,
- The 2.3 t base plate (3) is on the counterweight platform,

or, for the respective driving mode

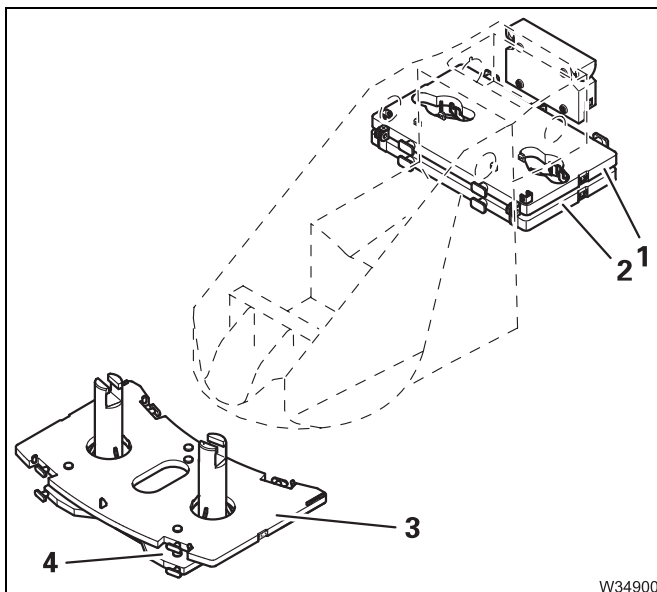

- The 2.3 t plates (1) and (2) are mounted on the turntable,
- The 2.3 t base plate (4) and the 2.3 t plate (3) lie on the counterweight platform.



## Rigging for crane operation

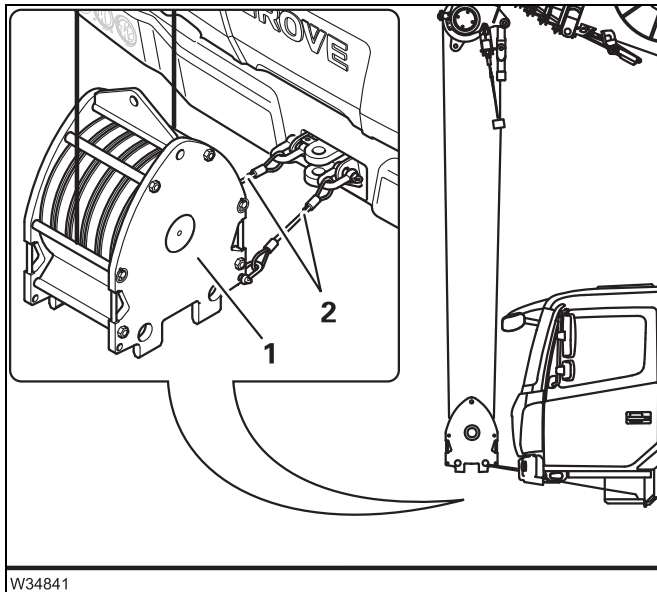

- Slacken the hoist rope and raise the main boom simultaneously.
- Raise the main boom until the boom head is in a vertical position above the block hook (1).
- Detach the block hook from the retaining ropes (2).

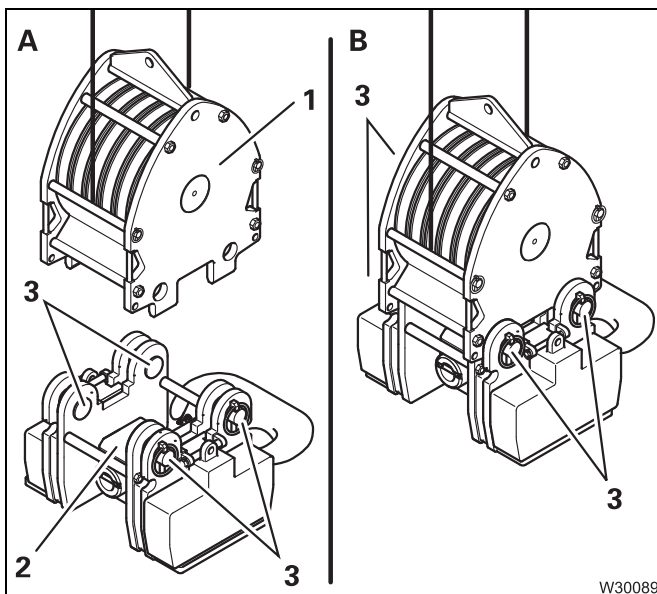

- (A) – Pull the pin (3) out.
- (B) – Raise the hook block (1) above the hook (2) until the connecting points are aligned.
- Insert the pins (3) and secure them with the retaining pins.

## Unreeving hoist rope

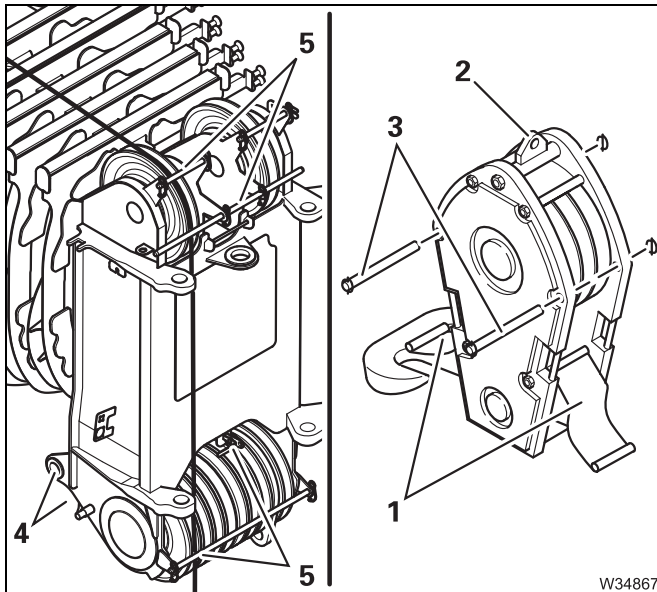

- Pull out the rods (5) and (3).
- Fold down the plates (1).
- Remove the rope end fitting from the fixed point (2) or (4).
- Unreeve the hoist rope.
- Insert the rods (5) and (3) and secure them.

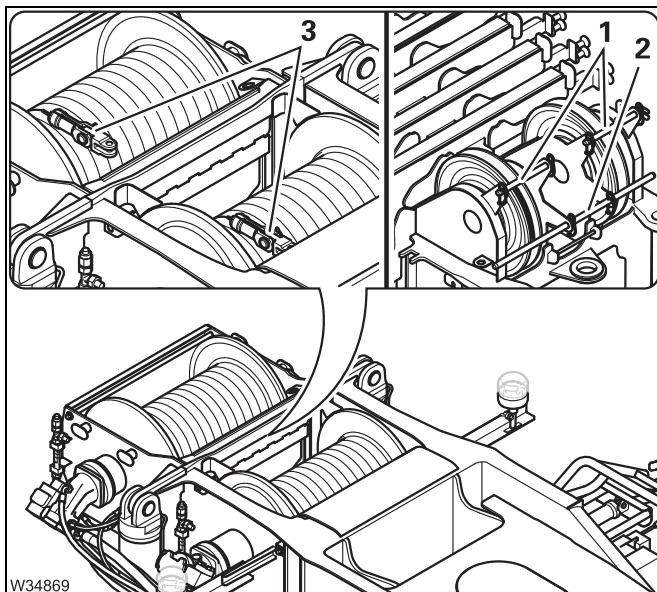

- Depending on the driving mode, you can:
- Fasten the hoist rope to the bumper;  
    ▶▶ p. 12 - 119 or
  - Pull out the rods (1), (2) and roll the hoist rope (3) on to the drum.
  - Insert the rods (1), (2) and secure them.
  - Secure the hoist rope (3).

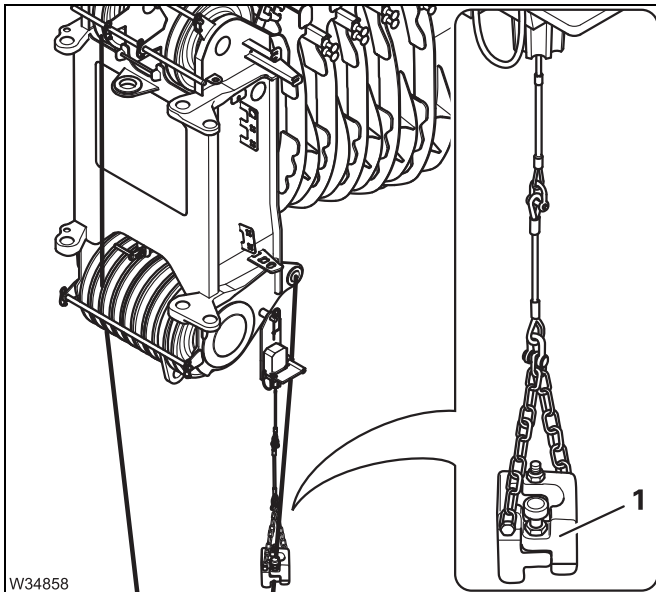

### Attaching the lifting limit switch weight

- Attach the lifting limit switch weight (1).

These lifting limit switches must not be blocked;  *Removing the lock*, p. 12 - 144.

If two hoist ropes are reeved, you must attach a lifting limit switch weight to each of the two lifting limit switches.

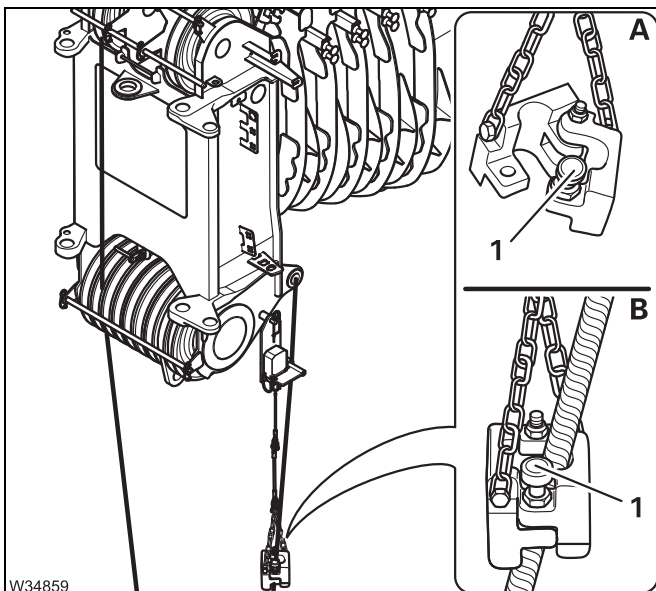

### Placing a lifting limit switch weight around the hoist rope

- (A) – Pull the safety pin (1) out and fold the two halves of the weight apart.
- (B) – Place the two halves of the weight around the last rope line leading upwards.
- Pull the safety pin (1) out and fold the two halves of the weight back together.
- Make sure the safety pin locks into place and the two halves of the weight are securely attached to each other.

If two hoist ropes are reeved, you must also place a lifting limit switch weight around the second hoist rope.



If you place the lifting limit switch weight around the last rope line leading upwards, less rope will run through the lifting limit switch weight, especially if there is a high number of reevings per lifting operation. This rope line will even be at a standstill if the number of rope lines is even.

This allows you to reduce the wear of the hoist rope and lifting limit switch weight and prevent unintentional deactivation procedures that may be caused by the running hoist rope lifting the lifting limit switch weight.



### 12.11.3

## Slings points for personal protective equipment

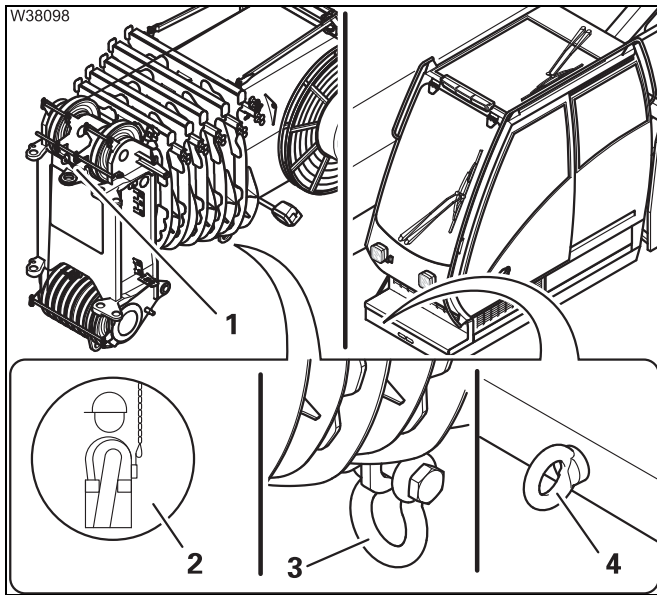

The labels (2) mark the approved slinging points for personal safety equipment, for example, slinging point (1).

The slinging options (3) and (4) are provided for the attachment of a fall protection device.

- Always use a slinging point (1) for securing yourself and your personal safety equipment or use an authorised fall protection device.



#### Risk of damage to the crane cab

Always use a fall protection device with activated abseiling function for the slinging point on the main boom.

This will prevent damage to the crane cab when raising.

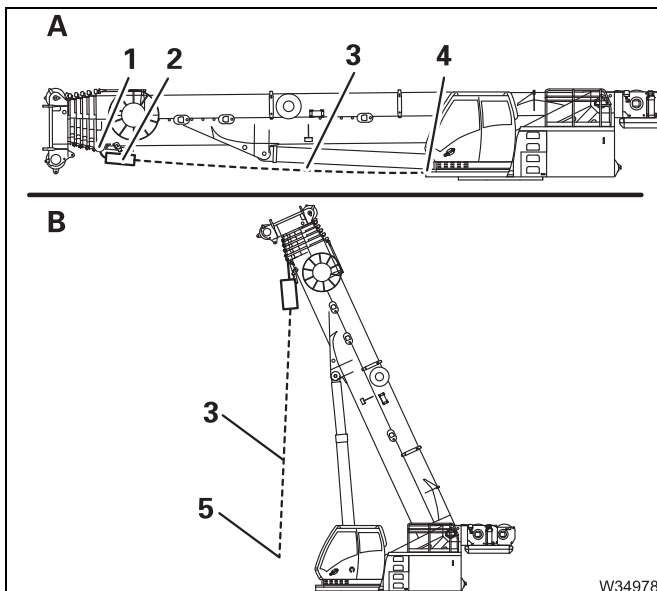

#### Fall protection device

- (A) – Lower the main boom.
- Sling the fall protection device (2) at the point (1).
- Guide the safety cable (3) to point (4) and fasten it.
- Make sure that the abseiling function on the fall arrester is activated.
- (B) – Raise the main boom and switch all power units off.
- Now connect the safety cable (3) to your personal safety equipment – at the point (5).

Counter weight in t (lbs)	Telescope status I - II - III - IV - V in %	Main boom Angle in °	Superstruc- ture position <sup>1)</sup>	Axle load <sup>2)</sup> in t (x 1,000 lbs)	
				front	rear
10.2 (22,487)	50 - 0 - 0 - 0 - 0	20 - 40	front	15.5 (34.2)	12.5 (27.6)
	0 - 0 - 0 - 0 - 0	80	rear	12.5 (27.6)	12.5 (27.6)
12.5 (27,558)	50 - 0 - 0 - 0 - 0	20	front	15.0 (33.1)	12.0 (26.5)
	0 - 0 - 0 - 0 - 0	65 - 80	rear	13.5 (29.8)	14.5 (31.9)
14.8 (32,628)	50 - 0 - 0 - 0 - 0	20	front	14.0 (30.9)	13.0 (28.7)
	0 - 0 - 0 - 0 - 0	60 - 80	rear	14.5 (31.9)	15.5 (34.2)
17.1 (37,699)	50 - 0 - 0 - 0 - 0	20	front	13.5 (29.8)	14.5 (31.9)
	0 - 0 - 0 - 0 - 0	70 - 80	rear	15.0 (33.1)	14.5 (31.9)
19.4 (42,770)	50 - 0 - 0 - 0 - 0	20	front	12.5 (27.6)	15.5 (34.2)
	0 - 0 - 0 - 0 - 0	80	rear	16.0 (35.3)	13.0 (28.7)
21.7 (47,840)	50 - 50 - 0 - 0 - 0	20	front	16.0 (34.2)	14.0 (30.9)
	0 - 0 - 0 - 0 - 0	70	rear	15.0 (33.1)	15.5 (34.2)
24.0 (52,911)	50 - 50 - 0 - 0 - 0	20	front	15.0 (33.1)	15.5 (34.2)
	0 - 0 - 0 - 0 - 0	70	rear	15.0 (33.1)	16.0 (35.3)
26.3 (57,982)	50 - 50 - 0 - 0 - 0	20	front	14.5 (31.9)	16.5 (36.4)
	0 - 0 - 0 - 0 - 0	65	rear	15.5 (34.2)	15.5 (34.2)
30.9 (68,123)	50 - 50 - 50 - 0 - 0	20	front	15.5 (34.2)	17.5 (38.6)
	0 - 0 - 0 - 0 - 0	65	rear	17.5 (38.6)	16.0 (35.3)
44.5 (98,106)	50 - 50 - 50 - 50 - 50	20	front	14.0 (30.9)	23.0 (50.7)
	0 - 0 - 0 - 0 - 0	50	rear	20.0 (44.1)	19.0 (41.9)

- 1) Rear: Display, slewing angle 0°  
Front: Display, slewing angle 180°
- 2) Front: on the first and second axle lines respectively  
Rear on the 3rd, 4th and 5th axle line

## 13.4

## Driving from the driver's cab



### Risk of accidents when driving the truck crane from the driver's cab with a lifted load!

With a lifted load, drive the truck crane only from the crane cab. You must be able to carry out crane movements in an emergency at all times.

### 13.4.1

## Preparing to drive

### Transmission

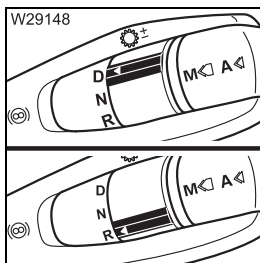

- In order to
  - for **forward travel** in position **D**,
  - drive **backwards**, shift to position **R**. An acoustic signal is given with additional equipment.

### Switching on separate steering

When driving the rigged truck crane, the separate steering must be switched on.



### Risk of damage to the steering linkage

Always switch on separate steering before driving the rigged truck crane and steer the truck crane only when it is rolling.

The steering linkage can be damaged if separate steering is switched off or if you steer the vehicle while it is stationary.

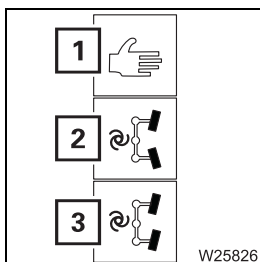

- Select and confirm the symbol
  - 1 – for Manual separate steering or
  - 2 – Separate steering automatic for driving around corners or
  - 3 – separate steering automatic for crab travel.

### Connections

If required, you can

- switch on the longitudinal differential locks; p. 5 - 51.
- switch on the transverse differential locks; p. 5 - 51.

### Switching the steering direction

The steering direction switched on is saved and is retained even after a restart.

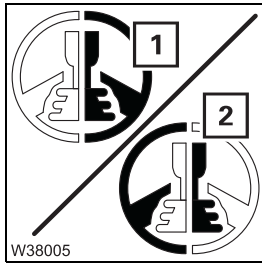

The display shows the currently set steering direction.

- 1 Steering direction *Steering wheel*
- 2 Steering direction *Reversed* (compared to steering wheel)

#### Switching over

- Select and confirm the desired symbol



All illustrations and descriptions in the following sections refer to the steering direction *Steering wheel*. When you switch to the *Reversed* steering direction, remember that the wheels will turn in the opposite direction.

### Displays when steering

The current steering angle of the wheels is displayed.

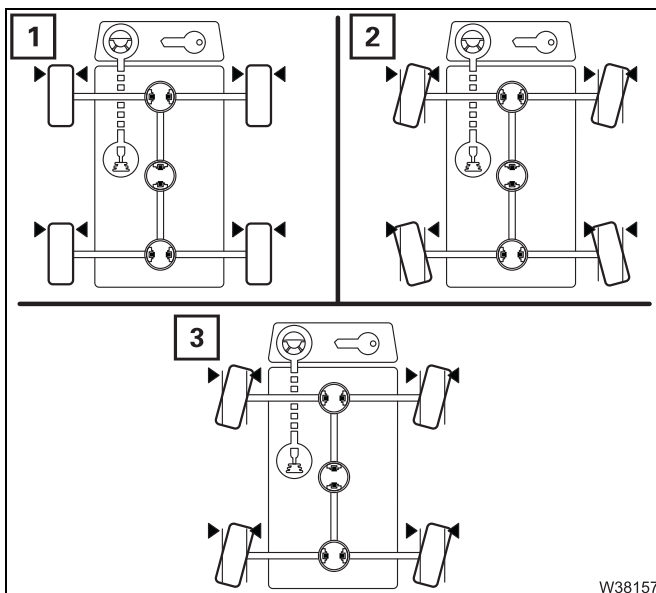

The symbols show the current steering angle:

- 1 Straight ahead position
- 2 Driving around corners
- 3 Crab travel mode



# 14

## Malfunctions during crane operation

### 14.1

### Emergency stop switch



#### Risk of overloading if used improperly

Press the emergency stop switch only if it is no longer possible to stop the crane movements with the normal operating elements.

The emergency stop switch stops the crane movements suddenly. This may overload the truck crane, e.g. in the event of high working speeds and large working radii.

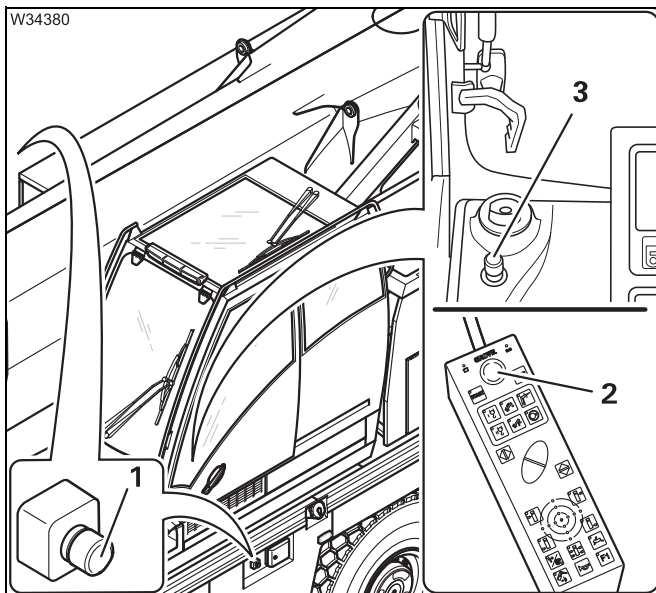

- Stop all crane movements.

Four emergency stop switches are provided for emergencies:

- 1 On the carrier
- 2 On the hand-held control unit
- 3 In the crane cab

- Press an emergency stop switch (1), (2) or (3). The switch latches.

The engine shuts down.

After activating an emergency stop switch;

▣▣▣▣ *Resetting the emergency stop switch, p. 4 - 19.*



The battery master switch cannot be used as an emergency stop switch for the engine. The engine continues to run after the battery master switch has been switched off.

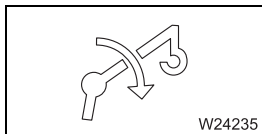

– **Lattice extension angle too small**

Raise the lattice extension; *Lattice extension operating manual.*

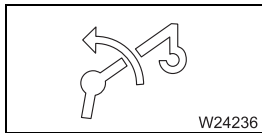

– **Lattice extension angle too large**

Lower the lattice extension; *Lattice extension operating manual.*

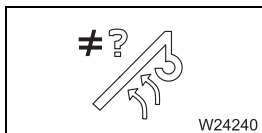

– **Boom extension angle not measured (different sensor values)**

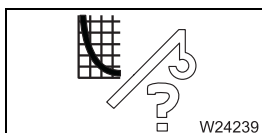

– **Main boom, lifting capacity table not present**

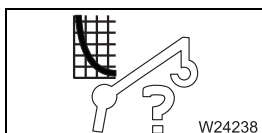

– **Lattice extension, lifting capacity table not present**



– **RCL override (switch 1) not actuated**



– **RCL override (switch 1) actuated**



– **RCL override (switch 2) not actuated**



– **RCL override (switch 2) actuated**



Malfunction		Cause	Solution
<b>Slewing only possible in one direction</b>		Shutdown angle of a limited slewing range reached (additional equipment).	Enter the RCL code for a slewing range of 360° ( <i>Standard</i> ) or reduce the working radius ( <i>MAXbase</i> ) or slew in the opposite direction to leave the shutdown angle
<b>Slewing not possible or only at low speed</b>		Speed limited	Increase limit; ▣▣▣▣▶ p. 11 - 125
<b>Slewing gear no longer responds to the control lever movement</b>		CCS malfunction	Emergency stop switch; ▣▣▣▣▶ p. 14 - 1
<b>No response to control lever movements</b>		CCS malfunction for operating elements in the crane cab	Unrig using hand-held control; ▣▣▣▣▶ p. 14 - 43

## Mechanical emergency activation

The following requirements must be met before manually unlocking a lock:

- The main boom must be lowered to the horizontal position so that the telescopic section cannot retract by itself.

or

- The telescopic section to be unlocked is secured against retracting by itself by using an auxiliary crane. Telescoping is done with the auxiliary crane.



### Risk of accidents due to sudden retraction of a telescopic section

Before unlocking the telescopic section, secure it against automatic retraction. This prevents the retracting telescopic section severing one of your limbs or the truck crane being damaged or overturned by the telescopic section suddenly retracting.



If the telescoping cylinder is positioned at a locking point, the corresponding telescopic section cannot be locked or unlocked manually.

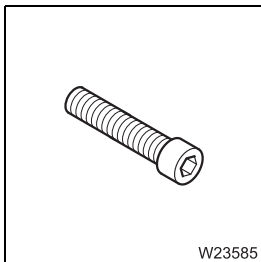

W23585

There are two **M8 x 110** bolts for every telescopic section.

These bolts are in the toolbox supplied with the crane.

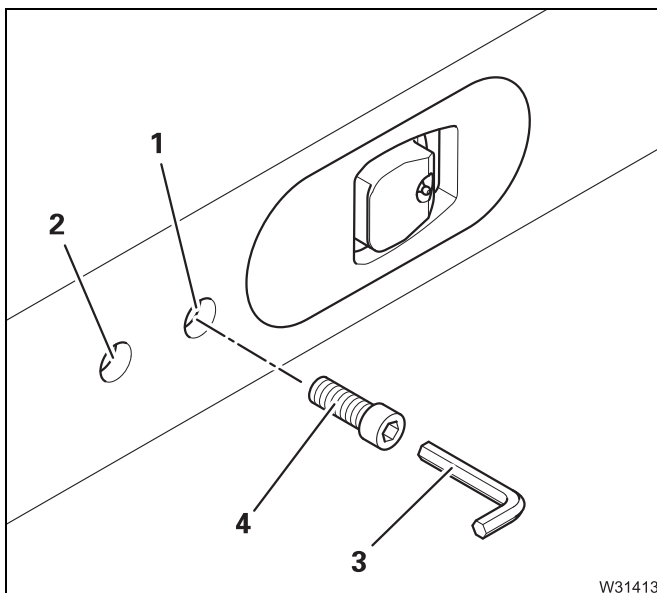

You will need a suitable tool (3), at least 250 mm (9.8 in) long.

In order to unlock the telescopic section, screw the bolts (4) into the bores (1) in the locking pins.

Pins located further inside are reached through the bores (2).



### 14.5.3

## Entering the current telescoping

CCS no longer displays the current telescoping

- if you telescoped in emergency mode, or
- if the power supply was interrupted in the course of saving data.

In these cases, you must enter the current telescoping, e.g. the values from the RCL display.

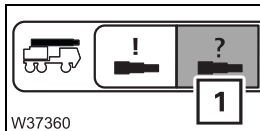

- Select and confirm the symbol (1) – the *Unknown telescoping* menu is opened.

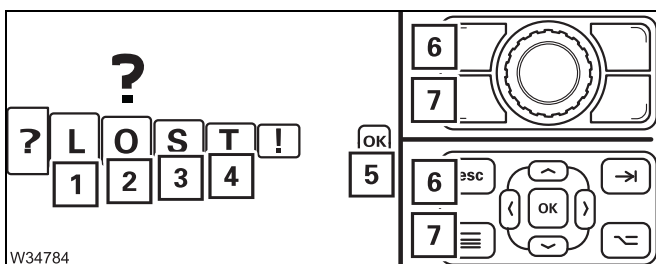

- Select and confirm the symbols (1) to (4).
- Confirm the entry with the symbol (5).

You can cancel the entry at any time using the (6) or (7) buttons.

After the correct input, the area for the set value input will be opened.

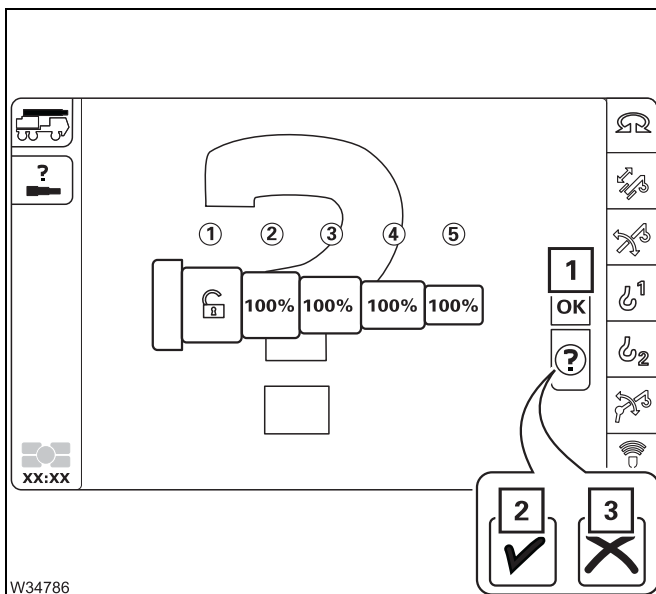

### Entering target values

- Select and confirm the symbols 1 to 5.
- Enter the desired target values for all telescopic sections, for example, *Unlocked, 100%, 100%, 100%, 100%*.
- Confirm the entry with the symbol (1).

Display symbol:

- 2 Permissible value
- 3 Impermissible value



## 14.6

## Hydraulic emergency operation with the hand pump



This section only applies to the standard hydraulic emergency operation. With the appropriate equipment you can also use the hydraulic emergency operation according to BGR 159; ■■■► p. 14 - 59.



### **Danger from mutual interference of the power units**

Check the positions of the valves **1** to **5** for the hydraulic emergency operation in accordance with BGR (in case available) and, if necessary, switch to *Crane operation*; ■■■► p. 14 - 67.

This prevents the power units suddenly starting to move.

### 14.6.1

### Operating principle

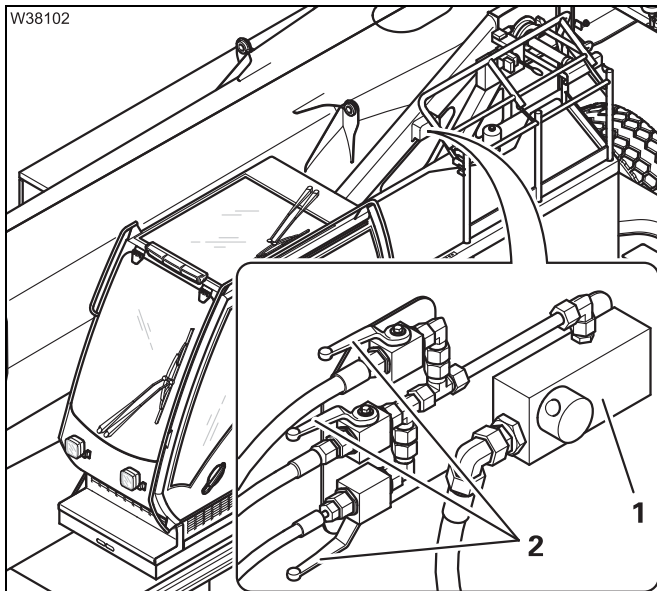

In hydraulic emergency operation, you can operate the derricking gear and perform the *Lower main hoist* movement, for example, to raise the main boom in the case of a defective engine.

The hand pump (**1**), which is activated by switching over a valve, is used as the energy source for the crane's hydraulic system.

The hydraulic circuits are switched via the valves (**2**).

The crane movements are performed by operating the hand pump.

## 14.7.2

### CHECKLIST: Emergency operation



This checklist is not a complete operating manual. There are accompanying operating instructions which are indicated by cross-references. **Observe the warnings and safety instructions specified here!**

#### 1. For emergency operation with self-sufficiency

- Attach and connect the transformer to the superstructure;  p. 14 - 63.

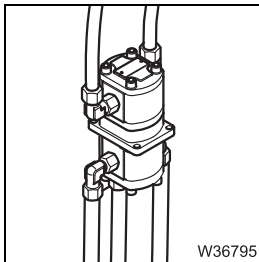

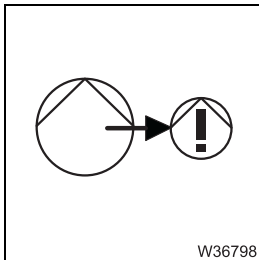

- Switching on emergency operation;  p. 14 - 65.

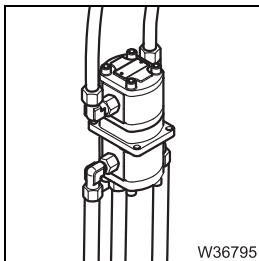

#### 2. For emergency operation with external energy source

- Attach and connect the transformer to the superstructure;  p. 14 - 66.



- 3. – Establishing the required hydraulic circuits;  p. 14 - 67.

- Carrying out emergency operation;  p. 14 - 71.

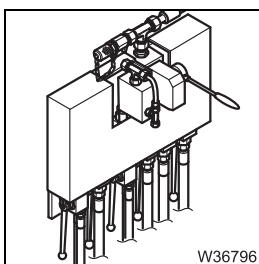

- 4. Put the truck crane into the original state;  *CHECKLIST: After emergency operation*, p. 14 - 62.

CLICK HERE TO **DOWNLOAD** THE COMPLETE MANUAL

- Thank you very much for reading the preview of the manual.
- You can download the complete manual from: [www.heydownloads.com](http://www.heydownloads.com) by clicking the link below



- Please note: If there is no response to CLICKING the link, please download this PDF first and then click on it.

CLICK HERE TO **DOWNLOAD** THE COMPLETE MANUAL