

Operating manual

Hydraulic excavator
R 996B

from serial number 26049

Document identification

ORIGINAL MANUAL

Order number: 10360931
Edition: 03 / 2021
Valid for: R 996B from serial number 26049
Author: LEC - Technical documentation department

Product identification

Manufacturer: Liebherr-Mining Equipment Colmar SAS
Type: R 996B
Type no.: 1281
Conformity:



Address

Liebherr-Mining Equipment Colmar SAS
49 rue Frédéric Hartmann
CS 50038, F-68025 Colmar Cedex

CLICK HERE TO **DOWNLOAD** THE COMPLETE MANUAL

- Thank you very much for reading the preview of the manual.
- You can download the complete manual from: www.heydownloads.com by clicking the link below



- Please note: If there is no response to CLICKING the link, please download this PDF first and then click on it.

CLICK HERE TO **DOWNLOAD** THE COMPLETE MANUAL

1.1.3 Undercarriage

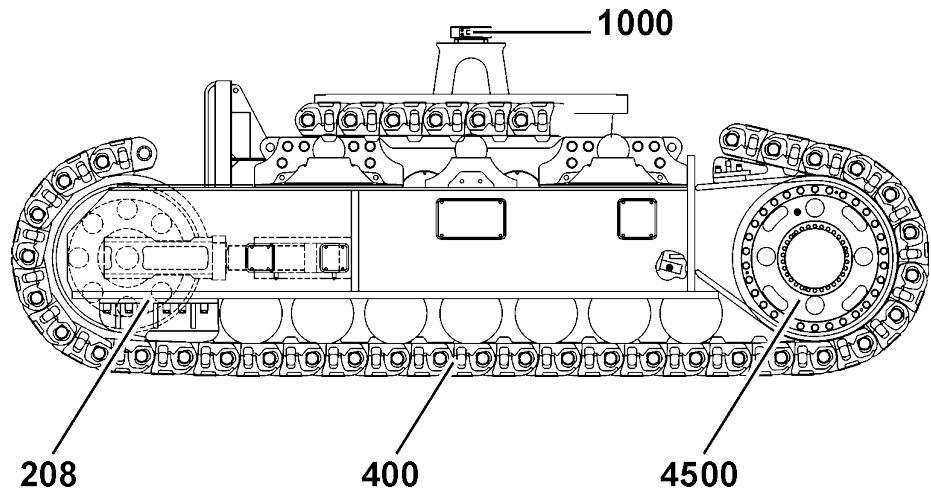

Fig. 1-3 Undercarriage

- | | | | |
|-----|-------------|------|---------------------------|
| 208 | Idler | 1000 | Rotary connection |
| 400 | Track chain | 4500 | Travel gear with sprocket |

1.2 Vibration emission

Designation	Unit	Value	Measurement uncertainty
Hand-arm vibrations	m/s ²	≤ 2,5	The measurement uncertainty is defined in standard EN 12096:1997
Whole-body vibrations	m/s ²	≤ 0,5	

Tab. 1-1 Vibration emissions

Operator's seat

- The operator's seat built into the machine by the manufacturer conforms to ISO 7096:2000, EM 6.

Hand-arm vibrations

- If the machine is operated as intended, the weighted (frequency-weighted) effective value of the hand-arm vibrations in accordance with ISO 5349-1:2001 is less than 2.5 m/s².

Whole-body vibrations

- The value conforms to the specifications of the technical report ISO/TR 25398:2006.
- As the specified values are individual effective values for specific typical application areas, only a limited assessment of the load imposed on the operator by whole-body vibrations is possible.
- In order to accurately assess the daily exposure of an operator over an 8-hour

LEC/en/Edition: 03 / 2021

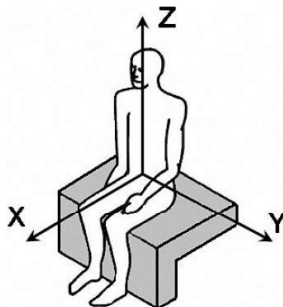

Built for Maximum Profitability

Electro-Hydraulic System Efficiency

Liebherr hydraulic technology in combination with the precision of electronic control contributes to the R 996 B's energy optimization. The high-pressure hydraulic system and the optimized pipe and hose layout maximize usable power transmission. The hydraulic pumps are electronically managed to provide optimal pressure compensation and oil flow management. The hydraulic system is independently regulated over the engine circuit for the best operational efficiency.

Independent Cooling System

Liebherr's large dimensioned cooling system reduces fan power consumption and ensures an ideal machine temperature. The hydrostatic fans operate always on the required level for optimal hydraulic oil cooling efficiency.

Closed Loop Swing Circuit

The Liebherr Mining excavators are all equipped with a closed loop swing circuit. Kinetic energy is regenerated when the swing motion deceleration, to drive the main and auxiliary pumps, reducing fuel consumption and allowing faster boom lift motion.



Comfort-Oriented Cab Design

An array of features:

- Tinted laminated safety glass
- Armored front and attachment side windows
- Heavy duty sun louvers on windows
- Adjustable air suspended seat
- A/C with dust filter in fresh air/recirculated
- Pressurization to prevent dust penetration
- Trainer seat



Fast Maintenance System

The service flap is hydraulically actuated and accessible from the ground level allowing for fast maintenance:

- Hydraulic oil refill
- Engine oil exchange
- Splitterbox and swing gearbox oil exchange
- Attachment/swing ring bearing grease barrel refilling with filters
- Windshield washer water refilling
- Fast fuel refilling line



Hydraulic System Efficiency

- Optimal oil flow distribution through the valves blocks reducing hydraulic losses
- Reduced pressure drops between pumps and consumers (hydraulic motors/cylinders)
- Allows the combination of the main movements under maximal forces
- Enables fast cycle times

Comfortable Cab for Efficient Work

The large and spacious cab which equips the R 996 B offers ideal working conditions and optimal operator's comfort. Mounted on silent blocks, the cab design reduces vibrations and limits noise pollution to provide a quiet environment.

Extended Components Lifetime

The R 996 B's high pressure hydraulic oil filtration systems remove contaminants from the fluid to offer the highest rate of hydraulic system efficiency. To maintain the oil quality, all return hydraulic oil flow goes through a 15/5 μm fine filtration system. To promote availability, the grease and fuel tanks are sized to considerably extend the time between service intervals.



Operator's Cab

Design	resiliently mounted, sound insulated, large windows for all around visibility, integrated falling object protection FOPS (ISO 10262)
Operator's seat	suspended, body-contoured with shock absorber, adjustable to operator's weight
Cabin windows	20.5 mm/0.8 in tinted armored glass for front window and 18 mm/0.7 in for left hand side windows, all other windows in tinted safety glass, high pressure windshield-washer system with 75 l/20 gal watertank, sun louvers on all windows in heavy duty design
Heating system/ Air conditioning	heavy duty, fully automatic, high output air conditioner and heater unit, contains fluorinated greenhouse gases HFC 134a with a Global Warming Potential (GWP) of 1430, the AC circuit contains 4.8 kg/ 10.6 lb of HFC-134 representing an equivalent of 6.9 tonnes/7.6 tons of CO ₂ , the 2 nd AC circuit (optional) contains 4.8 kg/ 10.6 lb of HFC-134 representing an equivalent of 6.9 tonnes/7.6 tons of CO ₂
Cabin pressurization	ventilation with filters, minimum pressurization of 50 Pa (ISO 10263-3)
Controls	joystick levers integrated into armrest of seat
Monitoring	via LCD-Display, data memory
Rear vision system	camera installation on counterweight and left-hand side of the uppercarriage, displayed over an additional LCD-display
Automatic engine shut off	in case of low engine oil pressure or low coolant level
Destroking of main pumps	in case of engine overheating or low hydraulic oil level
Safety functions	additional gauges with constant display for: engine speed, hourmeter, engine oil pressure, coolant temperature and hydraulic oil temperature
Noise level (ISO 6396)	L _{pA} (inside cab) = 78 dB(A)



Undercarriage

Design	3-piece undercarriage, box-type structures for center piece and side frames, stress relieved
Hydraulic motor	2 axial piston motors per side frame
Travel gear	Liebherr reduction gear
Travel speed	0 – 2.2 km/h/0 – 1.4 mph
Parking brake	spring engaged, hydraulically released wet multi-disc brakes for each travel motor, maintenance-free
Track components	maintenance-free combined pad-link, heavy duty track shoes
Track rollers/ Carrier rollers	7/3 per side frame
Automatic track tensioner	pressurized hydraulic cylinder with accumulator, maintenance free
Transport	undercarriage side frames are removable



Service Flap

Design	hydraulically actuated service flap, easily accessible from ground level to allow: <ul style="list-style-type: none"> – fuel fast refill – hydraulic oil refill – engine oil quick change – splitterbox oil quick change – swing gearbox oil quick change – swing ring teeth grease barrel refilling via grease filter – attachment/ swing ring bearing grease barrel refilling via grease filter – windshield washer water refilling other coupler type on request
---------------	---



Central Lubrication System

Type	single line lubrication system, for the entire attachment/ swing ring bearing and teeth
Grease pumps	2 hydraulic pumps for attachment/ swing ring bearing lubrication with switch over function 1 hydraulic pump for swing ring teeth lubrication
Capacity	600 l/ 158.5 gal bulk container for attachment/ swing ring bearing, separated 80 l/ 21 gal container for swing ring teeth
Refill	via the service flap for both containers with grease filters



Attachment

Design	box-type structure with large steel castings in all high-stress areas
Pivots	two floating pins per pivot, sealed covers, all bearings with wear resistant steel bushings, bolts hardened and chromium-plated
Hydraulic cylinders	Liebherr design, all cylinders located in well protected areas
Hydraulic connections	pipes and hoses equipped with SAE split-flange connections
Kinematics	Liebherr parallel face shovel attachment geometry
Pivots bucket-to-stick	O-ring sealed and completely enclosed
Pivots bucket-to-link	

- Do not use cold start materials (ether) in the vicinity of heat sources, naked flames or in inadequately ventilated areas.
- Do not use any starting aids containing flammable material to start diesel engines with preheating or flame glow systems. There is a risk of EXPLOSION.
- Familiarize yourself with the location and operation of fire extinguishers on the machine and with local fire warning and fire abatement options.
- It is possible to install an extinguisher into the driver's cab.
- All doors, covers and boxes locks have to be unlocked before operation in order to facilitate firefighting in case of fire. Only electrical boxes from and over 50V must remain locked during operation.

Bringing the machine safely into service

- Carry out a careful inspection tour around the machine each time before starting it.
- Ensure that no one, except an authorized person, is in the work and movement area of the machine.
- Check the machine for loose bolts, cracks, wear, leakage and damage.
- Never attempt to operate a damaged machine.
- Ensure that any damage is immediately rectified.
- Ensure that all hoods and covers are closed, but that locks are unlocked, to facilitate the fight against fire in case of.
- Ensure that all warning signs are present.
- Keep windows and interior and exterior mirrors clean. Secure doors and windows against unintended movement.
- Ensure that no one is working on or under the machine and warn personnel in the vicinity of the machine that it is about to start by sounding the horn.

Safely getting up

- Proceed with the same precautions to climb up or down onto the machine, as to install yourself at the operator's seat.
- When getting up or down, position the machine on even, horizontal ground. The upper structure should be positioned with the undercarriage in such a way that the steps and ladders are aligned with each other.
- Ensure that steps, ladders and hand-rails (grips) are in good condition. In particular, you should ensure that they are free of dirt, oil, ice and snow.
NOTE: To ensure that the doors open properly in all weather conditions, the door seals must be dusted with talc or silicon at least every two months or more often if required. The door hinges and locks should be greased regularly.
- Face the machine when getting in or out and always use three-point support, i.e. two hands and one foot or two feet and one hand must always be in contact with the access system at the same time.
- If you are able to reach the door handle with your free hand, open the doors before you climb any higher. External influences, such as wind, can make it more difficult to open doors. Because of this, always use your hand for control when opening doors. Ensure that the door is latched open to prevent it slamming open and shut.
- In case of bad weather conditions, be particularly vigilant to realise the climbing and descent from the cab with the best safety conditions, and do or give the instructions to the execution of prior preparations to be accomplished, as enunciated above, in order to displace yourself safely.
- Be particularly vigilant with those prerequisites conditions.

Transporting the machine safely

- Due to transport restrictions, use only suitable means of transport and lifting devices with sufficient load-carrying capacity.
- Park the machine on a flat surface and wedge the crawler or wheels securely.
- If required, detach a part of the machine's working attachment during transportation.
- The ramp used to drive the machine up onto the flatbed trailer should not exceed an inclination of the angle value indicated in the "Technical data" section of this manual (machine must be able to walk up unaided) and should have a wooden cover to prevent sliding back.
- The undercarriage should be swept clean, i.e. before driving up the ramp, clean any snow, ice and mud from the crawler / wheels of the machine.
- Align the machine precisely with the loading ramp.
- Attach the hand levers for fine-tune driving (crawler excavator) onto the travel pedals.
- Ensure that a spotter gives the machine operator the required signal.
- Prepare the placing block to ensure against rolling back when the machine is driving up onto the flatbed.
- Tilt the attachment up and drive up the loading ramp. While doing this, always hold the attachment securely over the loading area, drive very carefully up the ramp and onto the transportation vehicle.
- Rotate the uppercarriage carefully to the rear and lower the attachment. Due to restrictions during transport on hoe attachment, tilt the arm in and dismantle the bucket during transportation.
- After loading the machine onto the flatbed trailer, the upper structure must be secured facing the undercarriage using the stop bolts (only A devices).
- Secure the undercarriage and the remaining individual parts using chains and blocks to prevent slipping.
- Before you leave the machine, reduce pressure on all pressure lines, remove the ignition key and tilt up the safety lever.
- Lock all cab and panel doors.
- Before transportation, find out all details about the route to be travelled, particularly as they relate to width, height and weight restrictions.
- Pay particular attention when driving under electrical lines and bridges and through tunnels.
- When unloading the machine, take the same amount of care as was taken when it was loaded. Remove all chains and blocks. Start the engine as per the operating instructions. Drive carefully off the trailer's loading area and down the ramp. Hold the working attachment as securely as possible over the ground while doing this. Have a spotter guide you.

2.4 Servicing the machine safely

General safety instructions

- Maintenance and repair work may only be carried out by specially trained personnel.
- Observe statutory timetables or intervals given in the operating instructions for repeat tests / inspections. It is imperative that a suitably equipped workshop is available in order to carry out maintenance work.

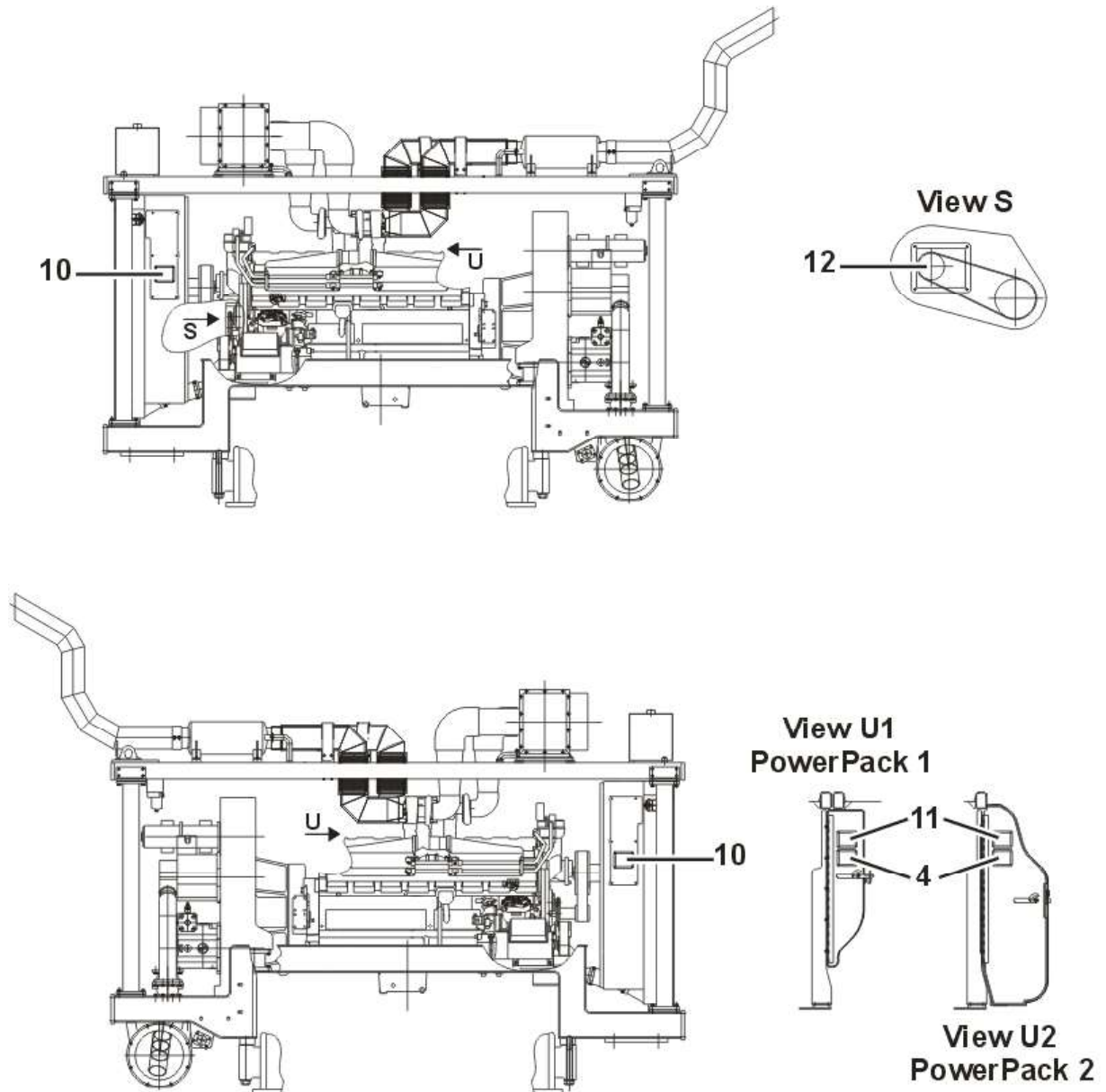

Fig. 2-2 PowerPack signs

- | | | | |
|----|-----------------------------|----|-------------------------------------|
| 1 | Typeplate LEC "CE" | 14 | Hydraulic valve position label |
| 3 | Typeplate LEC | 15 | Hydraulic tank pressure label |
| 4 | Oil injection hazard plate | 16 | Fuel tank pressure label |
| 5 | Banning label | 17 | External starting label |
| 6 | Emergency exit plate | 18 | Instruction manual warning label |
| 7 | Safety ladder plate | 19 | Control symbols label (backhoe) |
| 8 | Emergency stop label | 20 | Control symbols label (shovel) |
| 9 | Danger signal label | 21 | Safety lever label |
| 10 | Rotation blade hazard label | 22 | Hydraulic tank shut-off valve label |
| 11 | Burn hazard label | 23 | Collision risks label |
| 12 | Crush hazard label | 24 | Safety belt label |

LEC/en/Edition: 03 / 2021



Press button 31 - Travel brake

- ▶ Press button.
 - ↪ Travel brake is applied.
- ▶ Press button again.
 - ↪ Travel brake is released.

The travel brake is applied if the safety lever is operated or if the access ladder or the service trap is down.



Push button 32 - Swing brake

Use this button to switch the swing brake either in position "brake applied" or in position "semi automatic brake".

- ▶ Press button.
 - ↪ Swing brake shifts from one mode to the other.
 - ↪ Uppercarriage is locked.
 - ↪ LED in the button illuminates.
- ▶ Press button once again.
 - ↪ Swing brake is release.
 - ↪ Uppercarriage is unlocked.
 - ↪ LED in the button goes out.

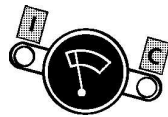

Push button 36 - Windscreen wiper

- ▶ Press switch.
 - ↪ Intermittent setting is activated.
 - ↪ LED I in the button illuminates.
- ▶ Press switch again.
 - ↪ Continuous operation is activated.
 - ↪ LED C in the button illuminates.
 - ↪ LED I in the button goes out.
- ▶ Press switch again.
 - ↪ Windscreen wiper is switched off.
 - ↪ LED C in the button goes out.

In addition, the break time for the intermittent setting can be adjusted:

- ▶ Select the intermittent setting and keep the button depressed.
 - ↪ After a few seconds, LED I in the button will start blinking rapidly.
- ▶ Release the button when the blinking duration has reached the desired break time. Adjustment is possible between 2 and 9 seconds.



Push button 39 - Windscreen washer

- ▶ Press and hold button.
 - ↪ Washing water will be sprayed onto the windscreen through the outlet nozzles.
 - ↪ The windscreen washer runs continuously.
- ▶ Release the button.
 - ↪ Washing water will be stopped.
 - ↪ Windscreen washer will run continuously for approx. another 3 seconds.



Push button 40 - Buzzer off

- ▶ Press button when error warning alarm sounds.
 - ↪ Error warning alarm turns off.
 - ↪ Error is acknowledge and.
 - ↪ Error code is stored.



E 566 - E 567 - E 568 - E 569 – Main pumps contamination
E 572 - E 573 - E 574 - E 575

This symbol appears if metallic particles have been deposited on the contamination switch of one of the main pumps (the pump number appears in the top corner of the symbol).

- ▶ Stop operation and turn the engine off.
- ▶ Notify the maintenance personnel.



E 570 - E 571 - E 576 - E 577 – Swing pumps contamination

This symbol appears if metallic particles have been deposited on the contamination switch of one of the swing pumps (the pump number appears in the top corner of the symbol).

- ▶ Stop operation and turn the engine off.
- ▶ Notify the maintenance personnel.



E 578 - E 579 - E 580 - E 581 – Main pumps overheating
E 584 - E 585 - E 586 - E 587

This symbol appears if the temperature on one of the main pumps increases above 92°C (198°F) (the pump number appears in the top corner of the symbol).

- ▶ Turn the engine off.
- ▶ Find and rectify the cause of the problem.



E 582 - E 583 - E 588 - E 589 – Swing pumps overheating

This symbol appears if the temperature on one of the swing pumps increases above 92°C (198°F) (the pump number appears in the top corner of the symbol).

- ▶ Turn the engine off.
- ▶ Find and correct the problem.



E 544 – External swing teeth greasing

This symbol appears if the swing teeth greasing system is defect.

- ▶ Find and rectify the problem.
- ▶ See also Lincoln servicing manual.



E 545 – Reserve



E 546 - E 547 – Engine air filter dirty

This symbol appears if an engine air filter is too dirty to operate correctly.

- ▶ Stop operation and stop the engine.
- ▶ Check condition of the engine air filter.
- ▶ Clean or change as necessary.

- doors. Lock the door.
- Now climb down to the ground.

3.2.1 Entering or leaving the cab

Climbing up



Caution!

Entering or leaving the cab incorrectly could lead to injury.

- ▶ Proceed with the same attention on exit or entry of the cab, as while climbing the machine.
- ▶ Ensure that the safety lever is always in its highest position when entering or leaving the cab.
- ▶ Always use the handholds provided for the purpose when entering or leaving the machine.
- ▶ Face the machine when getting in or out and always use three-point support, i.e. two hands and one foot or two feet and one hand must always be in contact with the access system at the same time.
- ▶ Never use the control elements as handles.
- ▶ Never jump from the machine.

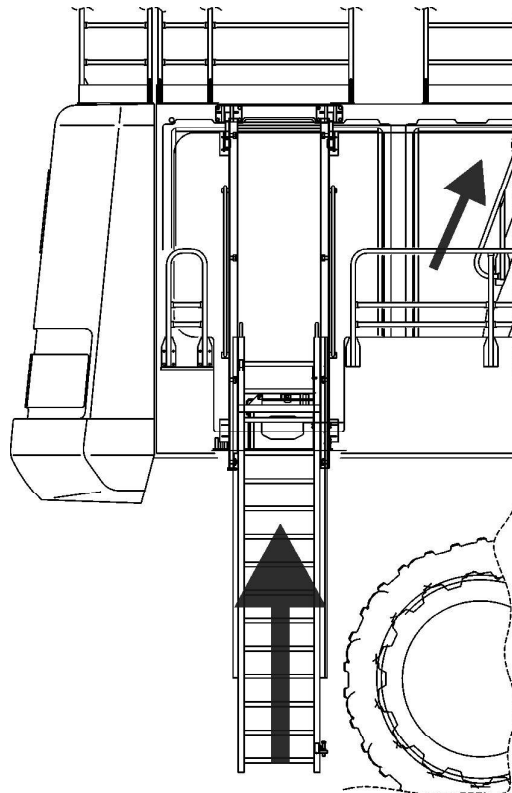

Fig. 3-21 Access ladder

Lateral emergency exit

You can use the rear right window of the cab as an emergency exit.

To open the emergency exit:

If the rear right window has an emergency handle:

- ▶ Pull the emergency handle on the inside of the window.
 - ↳ The window seal breaks into two parts and the window is released.
- ▶ Push the window out.

If the rear right window does not have an emergency handle:

- ▶ Break the window with the emergency hammer which is installed between the two right windows of the cab.

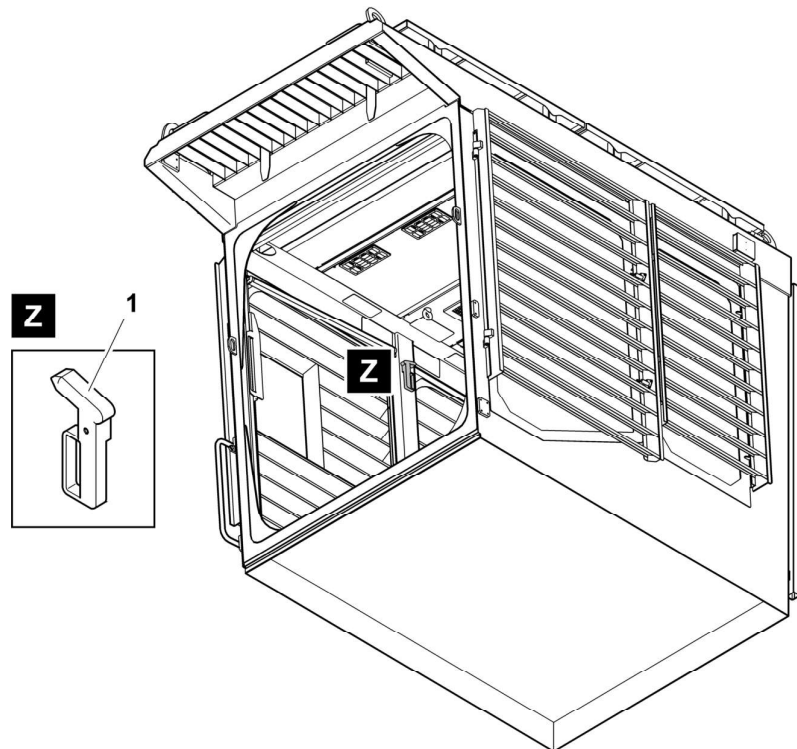

Fig. 3-34 Emergency hammer for the lateral emergency exit

Dual air conditioning (optional equipment)

When you switch the excavator on, the automatic dual air conditioning system is activated by default. The two air conditioning units are working alternately every 6 hours.

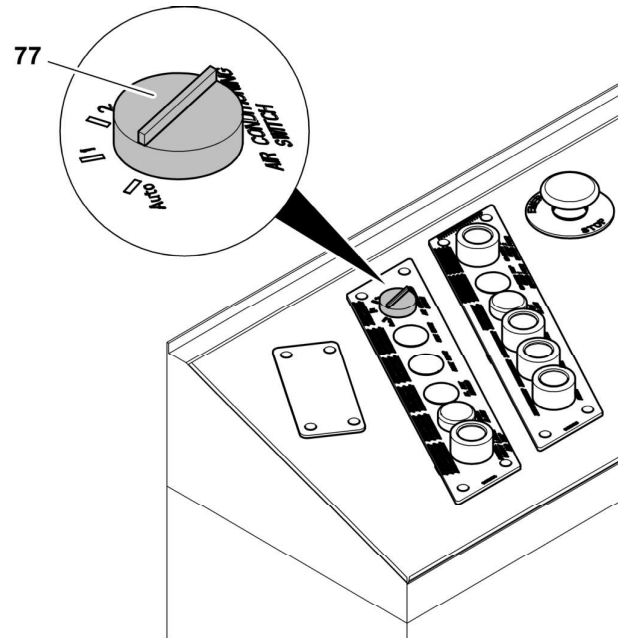

Fig. 3-42 Dual air conditioning switch 77 on control board

- ▶ Turn "Air conditioning switch" 77 on control board to pos. "1".
 - ↪ Automatic air conditioning mode is deactivated.
 - ↪ First air conditioning unit is activated.
 - ↪ Second air conditioning unit is deactivated.
- ▶ Turn "Air conditioning switch" 77 on control board to pos. "2".
 - ↪ First air conditioning unit is deactivated.
 - ↪ Second air conditioning unit is activated.
- ▶ Turn "Air conditioning switch" 77 on control board to pos. "Auto".
 - ↪ Automatic air conditioning mode is reactivated.

3.3 Setting the machine into operation

Bringing the machine safely into service

- Carry out a careful inspection tour around the machine each time before starting it.
- Ensure that no one, except an authorized person, is in the work and movement area of the machine.
- Check the machine for loose bolts, cracks, wear, leakage and damage.
- Never attempt to operate a damaged machine.
- Ensure that any damage is immediately rectified.
- Ensure that all hoods and covers are closed, but that locks are unlocked, to facil-

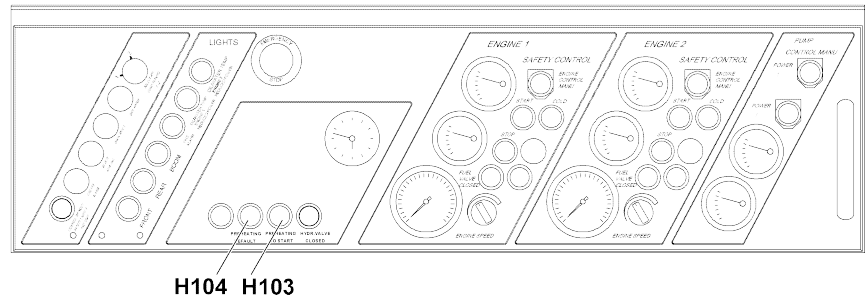

Fig. 3-47 H103 and H104 preheating additional indicators on control board

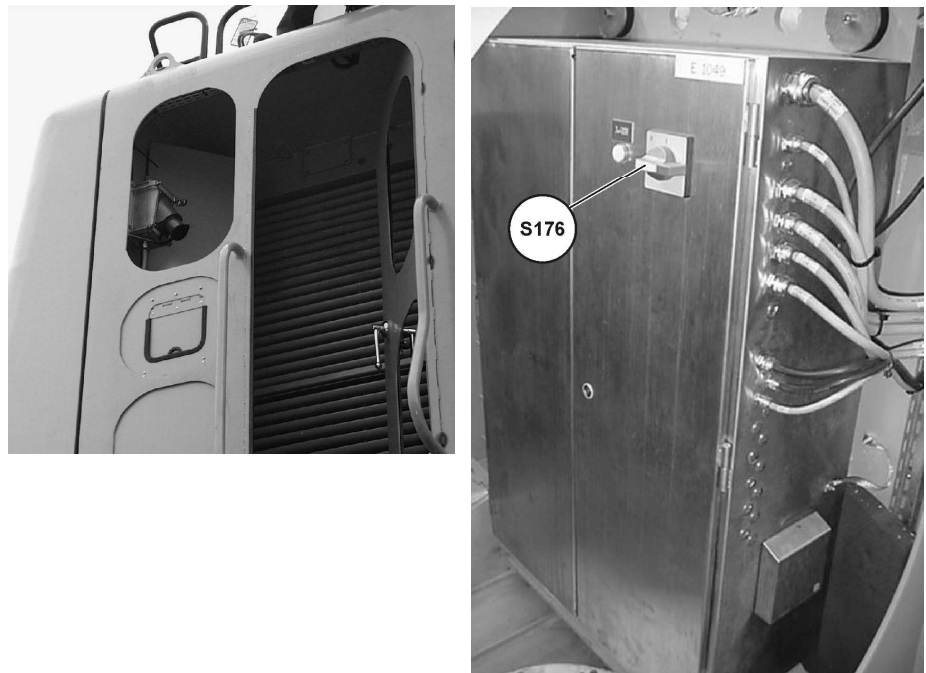

Fig. 3-48 Socket for power supply and switch S176

Preheating components

-30°C (-22°F) low temperature kit

This kit requires an 45kVA, 400V, 50Hz external power supply and must be activated every time the excavator is standing with external temperature between -30°C and 0°C (-22°F and 32°F) and weekend or service and maintenance day.

It consists of following components:

- engine cooling water equipment,
- engine oil immersion heaters,
- fuel heater,
- hydraulic oil immersion heaters,
- suction pipe immersion heaters,
- splitterbox immersion heaters,

LEC/en/Edition: 03 / 2021

Reversing:



Caution!

Before reversing, ensure that the area behind you can be safely entered.

- ▶ Push both pedals down (**5b** and **6b**).

Turning on the spot

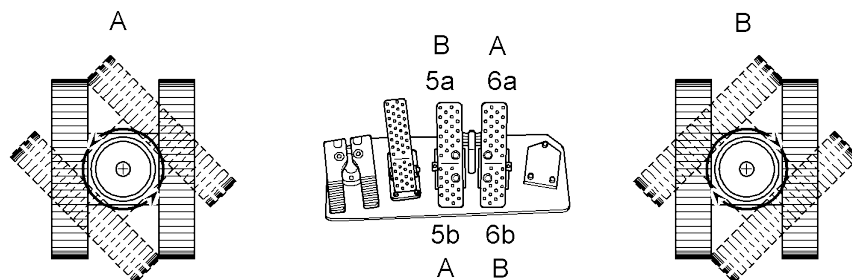

Fig. 3-54 Turning on the spot

Turning left (A):

- ▶ Push the left pedal down (**5b**).
- ▶ Push the right pedal forwards at the same time (**6a**).

Turning right (B):

- ▶ Push the right pedal down (**6b**).
- ▶ Push the left pedal forwards at the same time (**5a**).

Turning with a crawler

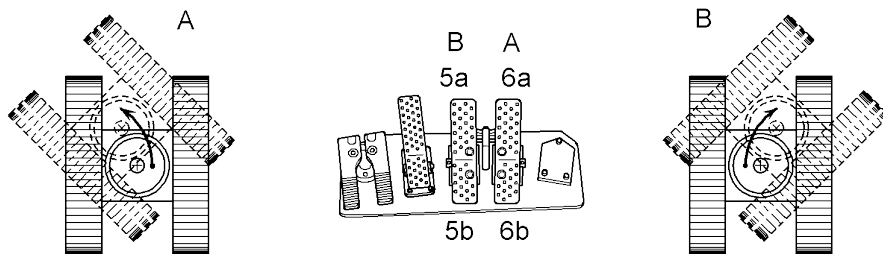

Fig. 3-55 Turning with a crawler

Turning to the left (A):

Push the right pedal forwards (**6a**).

Turning to the right (B):

Push the left pedal forwards (**5a**).

3.4.2 Operating the swing gear

Turning the uppercarriage

The swing movements of the uppercarriage are controlled by the left joystick.

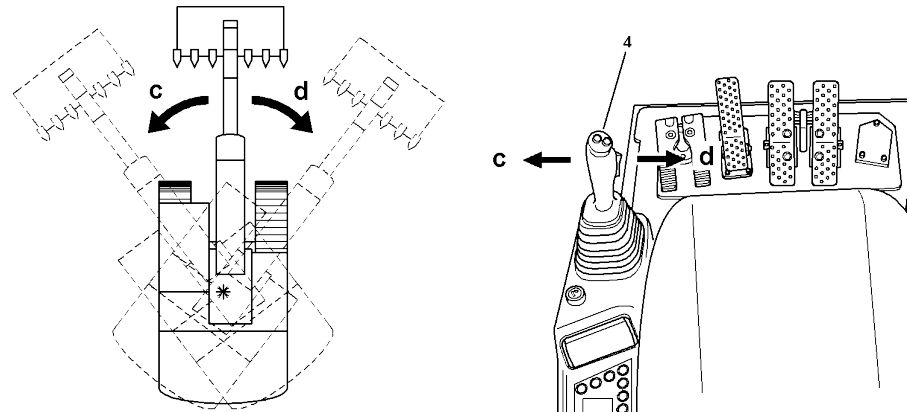

Fig. 3-57 Rotating the uppercarriage

- ▶ Push the left joystick to the left **c**:
 - ↪ The uppercarriage rotates to the left.
- ▶ Push the joystick to the right **d**:
 - ↪ The uppercarriage rotates to the right.

Braking the uppercarriage

The machine is equipped as well with an hydraulic as with a mechanical swing brake.

The hydraulic swing brake

- ▶ Let the left joystick move back to neutral position.
 - ↪ The hydraulically swing braking of the uppercarriage takes place. In normal working conditions, the braking efficiency is sufficient to bring the uppercarriage to a standstill rapidly.
- ▶ Move the left joystick in the opposite direction.
 - ↪ The maximum hydraulic braking action of the uppercarriage is achieved.

The mechanical swing brake

The mechanical brake is a negatively acting multidisc brake which is integrated in the swing gear. It allows to stop the uppercarriage in any desired position (for parking, when working on a slope, ...)

- ▶ Press button "Swing brake" button **32**.
 - ↪ Swing brake is applied.
 - ↪ LED in the button illuminates.
- ▶ Press button again.
 - ↪ Swing brake is released.
 - ↪ LED in the button goes out.



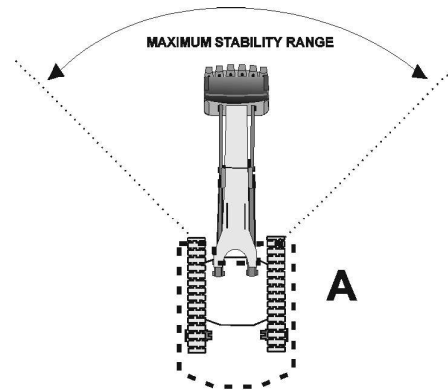

Fig. 3-68 Recommended digging

The recommended digging range is about a 90° arc in front of the machine (A).



Note!

Avoid digging at right angles to the tracks.

3.5.4 Working with the backhoe bucket



Danger!

Risk of fatal injury and damage to the machine when moving the backhoe bucket.

- ▶ Ensure that the backhoe bucket is not slewed too close to the cab.
 - ↳ The backhoe bucket could damage the cab and injure the machine's operator.
- ▶ Ensure that nobody is standing within the hazard area of the backhoe bucket.

Digging

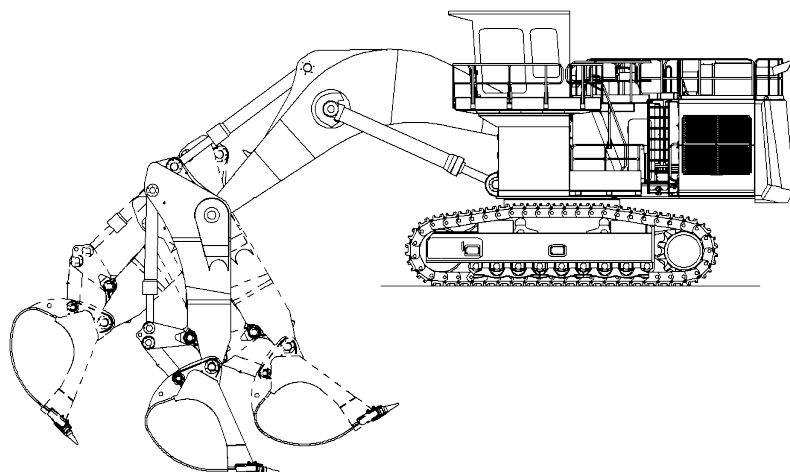

Fig. 3-69 Optimal angle for digging

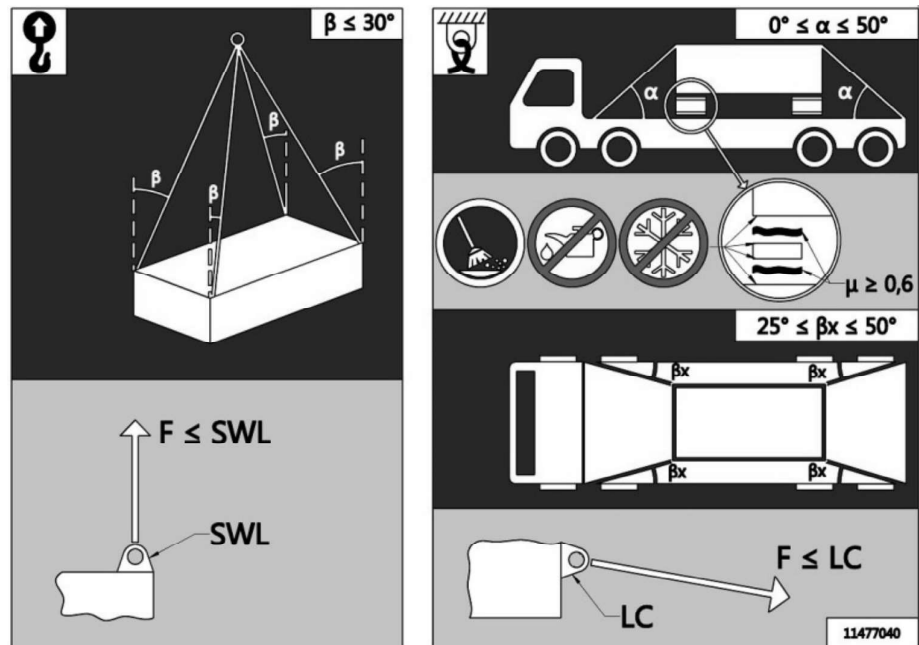

Fig. 3-77 Sticker for lifting and lashing operations

The Lashing Capacity **LC** is the maximum force that the lashing ring can hold in accordance with the angles given on the transport drawing.

The Safe Working Load **SWL** is the maximum load that the lifting ring can hold in accordance with the angles given on the transport drawing.

Transport drawings

The following drawings indicate the different lashing and lifting points on the elements of the excavator. Weight (with and without transport tooling and packaging), overall dimensions as well as center of gravity are also given.

The aim of these drawings is to ensure safe operation during transport, handling and storage.



Note!

The lashing and lifting points are indicated on the concerned elements of the excavator by specific labels (see § "Signs on the machine"). To be easily recognized, lifting points are painted in yellow (in red if excavator is yellow) as well.



Danger!

The lifting points given on a transport drawing for an element are designed to lift this element only and nothing else.

- ▶ Never lift an assembly of several elements by the lifting points of only one of these elements.

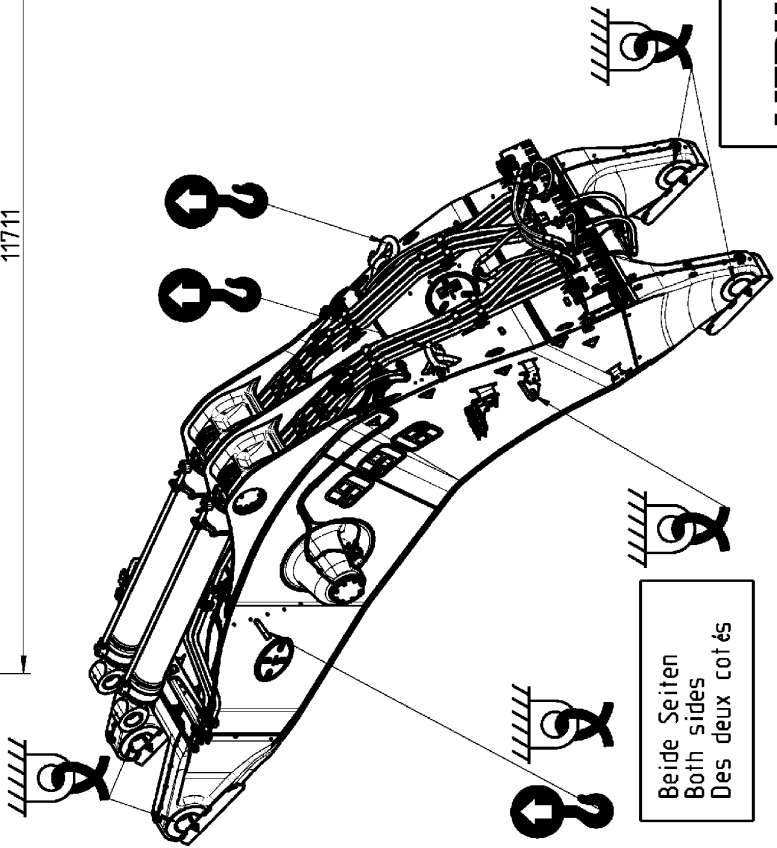
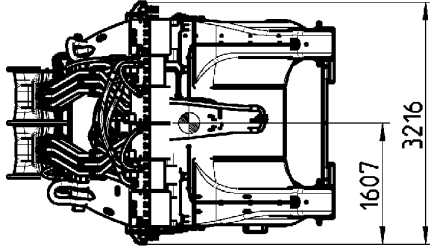
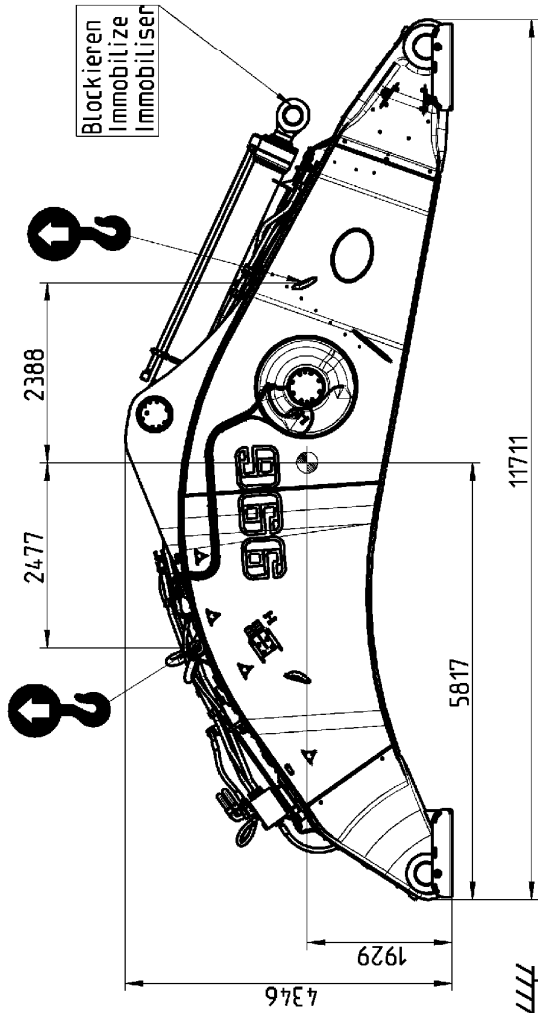

⊕
SCHWERPUNKT
CENTER OF GRAVITY
CENTRE DE GRAVITE

Gerechnet Calculated Calculé	Gewogen Weighed Pesé	Blatt / Page Feuille
65 533 kg		1/1
65 935 kg		

Gewicht ohne Werkzeug und Verpackung
Weight without tool and packaging
Poids sans outillage et emballage

Gewicht mit Werkzeug und Verpackung
Weight with tool and packaging
Poids avec outillage et emballage

Bezeichnung / Description / Désignation

TRANSPORTPLAN MONOBLOCKAUSLEG.
TRANSP.DRW.600SENECK BOOM
PLAN DE TRANSP.FLECHE RETRO



LIEBHERR

Ident.-Nr. / Ident. No.
N° d'ident



10820782

Index / Index
Index

003

 Fault / error	 Cause	 Solution
Engine starts but stops immediately after or runs irregularly	Fuel tank empty (low pressure in tank)	Fill tank and vent fuel system
	Fuel filter dirty	Clean or change filter and vent fuel system (tank)
	Particularly in winter: too viscous engine oil used	Use engine oil suitable for the outside temperature
	Dry-air filter dirty	Change main filter element
	Air in fuel system	Bleed fuel system
	Ventilation in fuel tank obstructed	Clean
	Fuel line bent	Check line and repair if required
Diesel engine emitting grey or black smoke	Dry-air filter dirty	Change filter
Diesel engine continually emitting white smoke (steam)	Water in combustion chamber	Consult customer service
Diesel engine does not reach full speed	Speed adjustment not set to maximum value	Set speed adjustment to maximum value
	Injection system is set incorrectly	Consult customer service
	Dry-air filter dirty	Replace filter
	Bad fuel supply	Clean or change fuel filter, check lines, drain water from tank
Diesel engine becomes too hot	Too little coolant	Fill coolant, check for leaks
	Water pump defective	Repair
	Thermostats do not work	Change thermostats
	Coolant contaminated	Clean coolant
Diesel engine has insufficient oil pressure Note! Switch off diesel engine immediately	Oil level too low	Correct oil level
	Oil pressure display faulty	Change oil pressure switch
Diesel engine consumes too much oil	External leak on diesel engine	Retighten screws, replace seals if required
Oil in coolant or coolant in oil		Consult customer service
Unusual noise / sound development on exhaust side	Exhaust system leaking	Check exhaust system / repair

4.2.2 Hydraulic system

 Fault / error	 Cause	 Solution
Unusual noise / sound development at hydraulic pumps Note! Switch off diesel engine immediately	Shutoff valve on hydraulic tank closed	Open the shutoff valve
	Hydraulic pumps taking in air	Check oil level in hydraulic tank, check intake lines for leaks
Hydraulic oil temperature too high	Coolant contaminated	Clean coolant
	Fan or fan control defective	Rectify error / consult customer service

LEC/en/Edition: 03 / 2021

CLICK HERE TO **DOWNLOAD** THE COMPLETE MANUAL

- Thank you very much for reading the preview of the manual.
- You can download the complete manual from: www.heydownloads.com by clicking the link below



- Please note: If there is no response to CLICKING the link, please download this PDF first and then click on it.

CLICK HERE TO **DOWNLOAD** THE COMPLETE MANUAL

- correctly adjusted.
- Control the surroundings, and particularly the nearness area of the machine, during operation or when travelling.
 - Mirrors are installed on the machine:
 - on the left to check the left side of the machine.
 - on the front to check the front side of the machine.
 - on the right to check the right side of the machine.
 - above the counterweight to check the rear side of the machine.
 - On some machines, some mirrors may be replaced with cameras.
 - At each extension, construction or change on the machine, the sight conditions must be maintained. These conditions must otherwise be checked according to ISO 5006.
 - Mirrors and cameras must always be clean.
 - Damaged mirrors and cameras must be immediately replaced.
 - The site has to be organised so that the dangers due to a restricted field of view are minimized, particularly for machines with an operating weight which is superior to 40 tons.

Crack testing

- Even when the machine is operated carefully, there is a possibility of individual cases of overloading occurring, which could lead to cracks or loose connections. The machine should therefore be checked regularly for cracks, loose connections or other visible damage to maintain operational safety.
- In order to be able to check for cracks, it is essential that the machine is kept clean and cleaned regularly.
- The tests should be carried out in accordance with the monitoring and maintenance plan:
 - every 250 operating hours by the machine owner's maintenance personnel.
 - every 500 operating hours by authorised specialist personnel.
- It is advisable to carry out these tests: supported, on firm, horizontal substrate, with the equipment in longitudinal and cross direction for variable loads. Current accident prevention regulations must be adhered to.
- Especially check the supporting components, in particular:
 - framed construction undercarriage with axle and gearbox storage, support outrigger, lower slewing ring support with tower and slewing ring.
 - framed construction uppercarriage with bearing for boom and hoist cylinder, upper slewing ring support, cab suspension, mounting for slewing gear and counter weight.
 - framed construction components of attachments, e.g. boom, stick, quick change adapter, digging tool and grapple.
 - hydraulic cylinders, axles, steering, pins and pin connections, ascents, ladders and mounting elements.
- The crack test should be carried out visually. If a crack is suspected, the dye penetration test should be carried out as a crack test on areas which do not have good visibility, such as the ring bearing support, in order to increase testing safety.
- Any damage found must be rectified immediately. Welding work on load-bearing parts of the earth-moving machinery, loading devices and transport devices may only be carried out by trained specialist personnel and only in accordance with the accepted rules of welding engineering. In case of doubt, contact the LIEBHERR customer support service to discuss suitable remedies.

Drilled anchor points

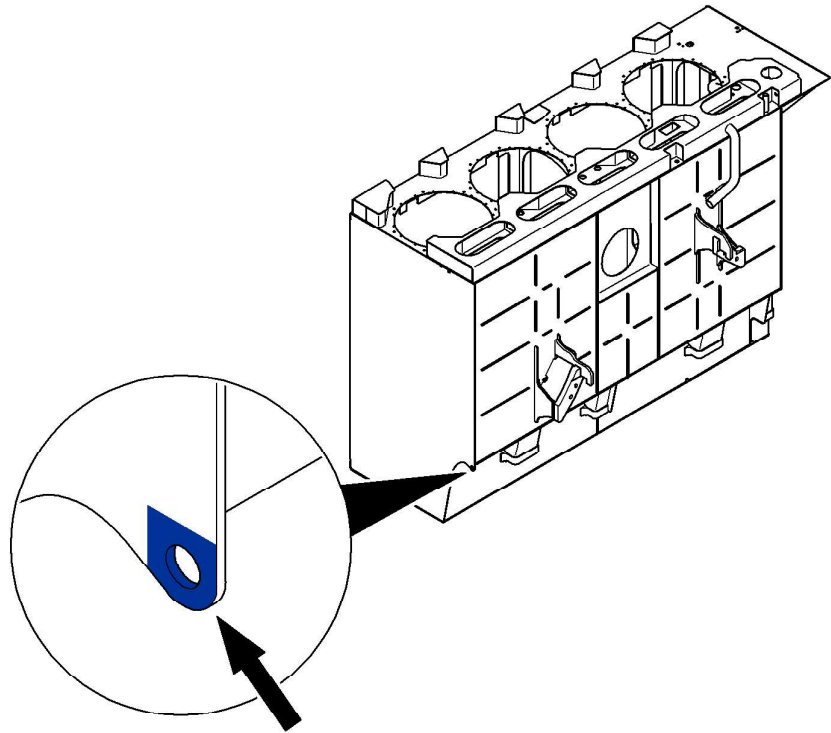

Fig. 5-4 Drilled anchor point (example)

5.3.2 Use the anchor points

- ▶ Before you use an anchor point, always do a check of its condition.
- ▶ If an anchor point has been used to arrest a fall, or if you are not sure about its safe condition, do not use this anchor point until it has been inspected and, if necessary, tested by a competent person.
- ▶ Always use the anchor points with applicable fall-arrest equipment.
- ▶ Use a harness with a maximum arrest force of 6 kN.
- ▶ Only attach to approved anchor points.
- ▶ Never attach more than three persons to a lifeline.
- ▶ Never attach more than one person to another type of approved anchor point. If several persons must attach themselves to the machine, they must use different anchor points.
- ▶ Never use an anchor point to attach parts or material.
- ▶ Persons who must work with fall-arrest equipment must be specially trained.
- ▶ All the anchor points and the tightening of the handrails mounting screws must be examined by authorized specialist personnel. For maintenance intervals, refer to the control and maintenance chart.

LIEBHERR oils for hydraulic system

Requirements

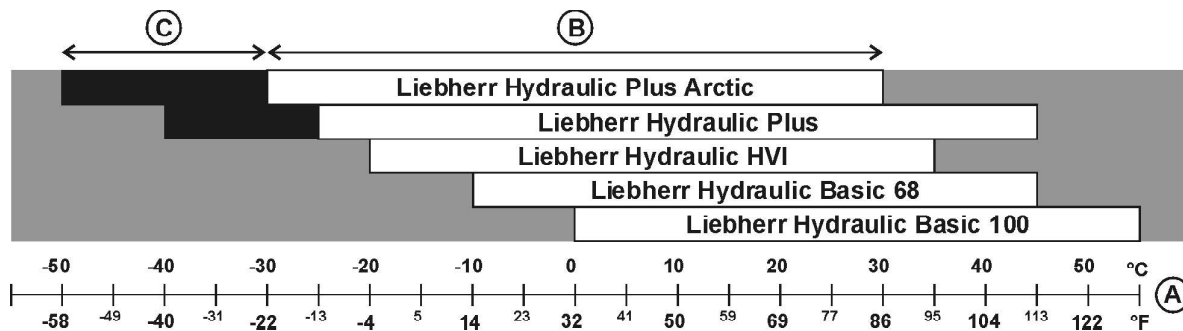

Fig. 5-8 LIEBHERR oils for hydraulic system

- A Ambient air temperature
- B Operating range
- C Extra-cold start range if excavator fitted with operating Liebherr arctic kit (with warm-up instruction)

Fans speed regulation settings

LIEBHERR oil	fans speed regulation setting
Liebherr Hydraulic Plus	"STANDARD"
Liebherr Hydraulic Basic 68	"STANDARD"
Liebherr Hydraulic Basic 100	"STANDARD"
Liebherr Hydraulic HVI	"COLD"
Liebherr Hydraulic Plus Arctic	"EXTRA-COLD"

Engine oils for hydraulic system

Requirements

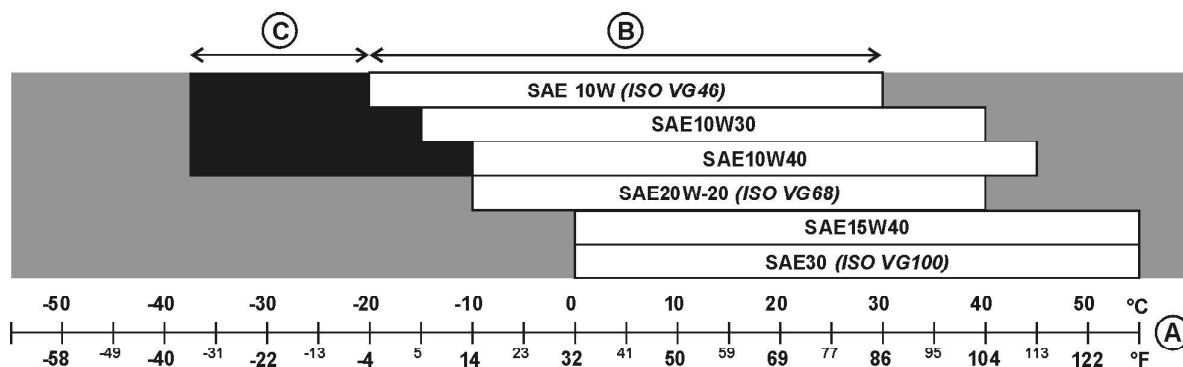

Fig. 5-9 Engine oils for hydraulic system

LEC/en/Edition: 03 / 2021

Lubricant	Description / manufacturer
Anti-corrosion grease for open piston rods (cylinders that do not move often or transportation)	Liebherr Cylinder Protect

5.6 Condition monitoring with oil analysis

5.6.1 General information

Oil analysis helps to monitor the main components condition by observing oil chemical and physical properties which can show either the oil contamination by foreign or wear particles, or the degradation of its properties.

Component oil analysis in accordance with the recommended procedures, intervals and specifications and the records of a component oil analysis are strongly recommended because this will support any warranty claim raised upon LIEBHERR.

By comparing the oil properties and contaminants to reference levels and even more by observing their trends over a period of operation, it is possible to optimize the component lifetime, possibly to prevent further damage (preventive exchange) and potentially to reduce rebuild and maintenance costs.

An oil analysis will give an indication of the component condition. But the measured values and their trend over a period of operation need always to be interpreted in relation to the machine operating conditions and to events such as services, top-up, component change-out, etc.

The interpretation of the analysis results need also to be compared to samples of the new oil. Therefore, new oil needs to be analysed twice a year and when changing to another oil supplier.

This procedure is applicable for these components:

- splitterbox(es)
- swing gears
- travel gears (not on pontoon machines)
- hydraulic oil
- Diesel engine(s) (not on electrical machines)

These parameters must be monitored:

- iron level
- copper level
- silicon level
- water content
- viscosity change
- additives change (e.g. Ca, Mg, B, Zn, P, Ba or S)

5.6.2 Oil sampling

Sampling intervals

- For each component, get an oil sample according to the Control and maintenance

Hydraulic oil

Component	Parameter	Action level value	Action
Hydraulic oil	Silicon level	15 ppm	Check for entrance of dust (cylinders, breathers...) (get a sample again after 250 hours).
	Viscosity change (at 40°C and 100°C)	<15% ^(*)	Change oil (get a sample again after 250 hours).
	Water content	0,10%	1. If the machine has a bypass filter element with water separator installed, replace the filter. <ul style="list-style-type: none"> – If not available, use an external filtration system until you get a satisfactory range. – If not available, change oil. 2. Get a sample again after 250 hours. If the results are still out-of-range: <ul style="list-style-type: none"> – Use an external filtration system until you get a satisfactory range. – If not available, change oil.
	Particle Quantification (PQ Index)	50	1. Change the return filters, pilot oil filters, leak oil filters and replenishing filters. 2. Get a sample again after 250 hours. If the results are still out-of-range: <ul style="list-style-type: none"> – Use an external filtration system until you get PQ Index < 20 or less. – If not available, change oil.
	Cleanliness level (ISO 4406)	21/19/16	1. Change the return filters, pilot oil filters, leak oil filters and replenishing filters. 2. Get a sample again after 250 hours. If the results are still out-of-range: <ul style="list-style-type: none"> – Use an external filtration system until you get contaminant code 20/18/15 or less. – If not available, change oil.

^(*) Difference compared to new oil value.

Diesel engine

Component	Parameter	Action level value	Action
Diesel engine	Please contact your engine manufacturer local representative.		

LEC/en/Edition: 03 / 2021

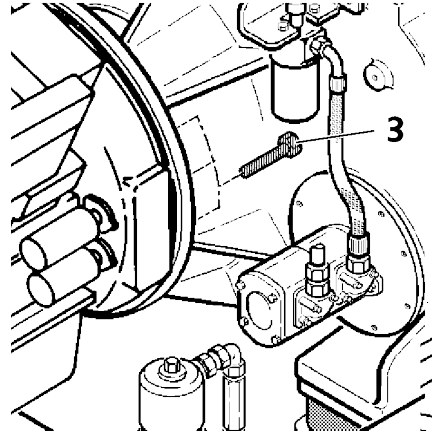

Fig. 5-29 Mounting screws

3 Hex. head screw 142 Nm

- ▶ Check the tightness of mounting screws **3** from the splitterbox to the diesel engine SAE housing regularly.
- ▶ For maintenance intervals, see control and maintenance chart.

5.8.2 Elastic bedding

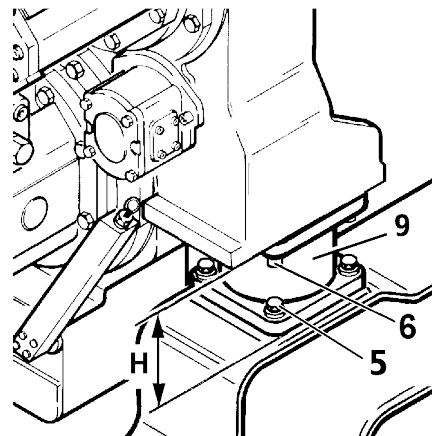

Fig. 5-30 Elastic bedding

- ▶ The two rubber buffers **9** at the splitterbox side must be checked and replaced at regular intervals.
- ▶ In addition, the height **H** (total height, including steel plates) of the rubber buffers **9** must be checked regularly: should height **H** be below the minimal acceptable height of 192 mm (7,56"), so the buffers **9** have to be replaced.
- ▶ For maintenance intervals, see control and maintenance chart.

5.12.2 Air dryer

The air dryer in the air pressure circuit dries and filters the compressed air.

Depending on the machine, there are two types of air dryer:

- the air dryer with filter element
- the cartridge-type air dryer

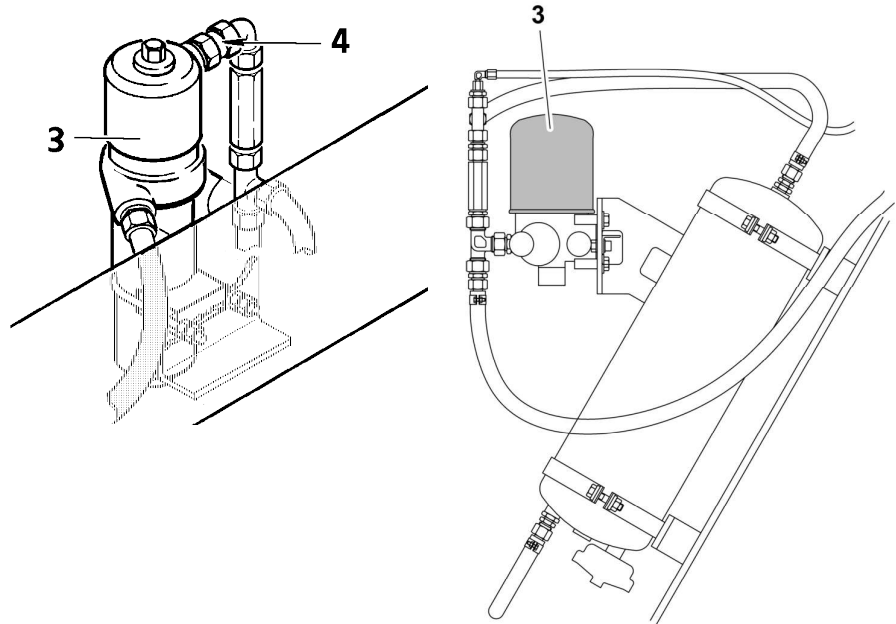

Fig. 5-41 Air dryer with filter element (left) and cartridge-type air dryer (right)

- 3 Air dryer
- 4 Air pressure line outlet

The filter element or the cartridge must be replaced at regular intervals.

► For maintenance intervals, see control and maintenance chart.

Replace the filter element

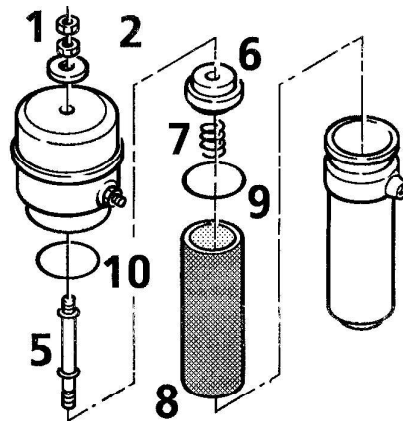

Fig. 5-42 Air dryer

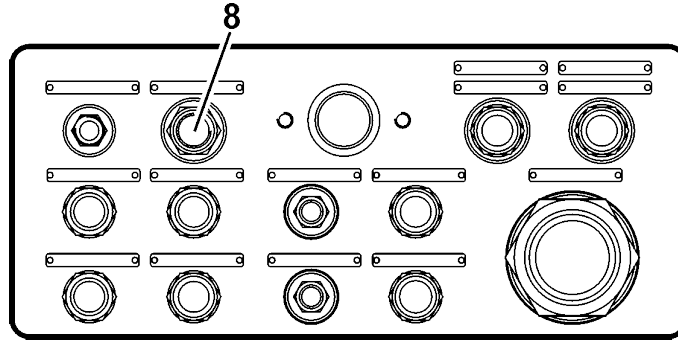

Fig. 5-52 Hydraulic oil change coupling on service trap

- ▶ Open hydraulic tank pressure release valve.
- ▶ Use the quick change coupling **8** of the service trap to drain and refill hydraulic oil until oil level reaches the center mark of the inspection window.
- ▶ Close hydraulic tank pressure release valve.

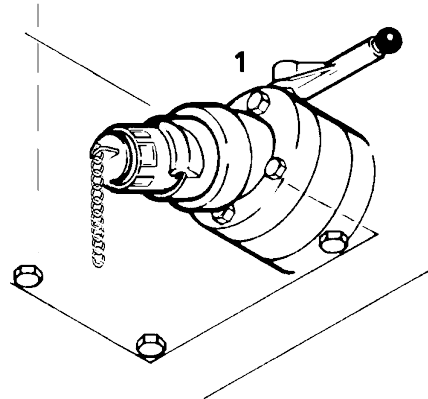

Fig. 5-53 Hydraulic tank shut-off valve

- ▶ As a help way, the hydraulic system can be drained using a drain hose via the drain coupling and the shut-off valve **1** at the bottom of the tank.

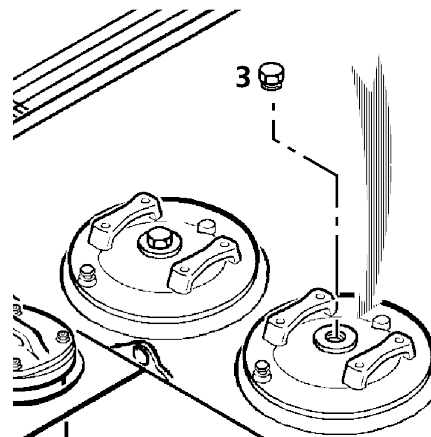

Fig. 5-54 Return filters on hydraulic tank

LEC/en/Edition: 03 / 2021

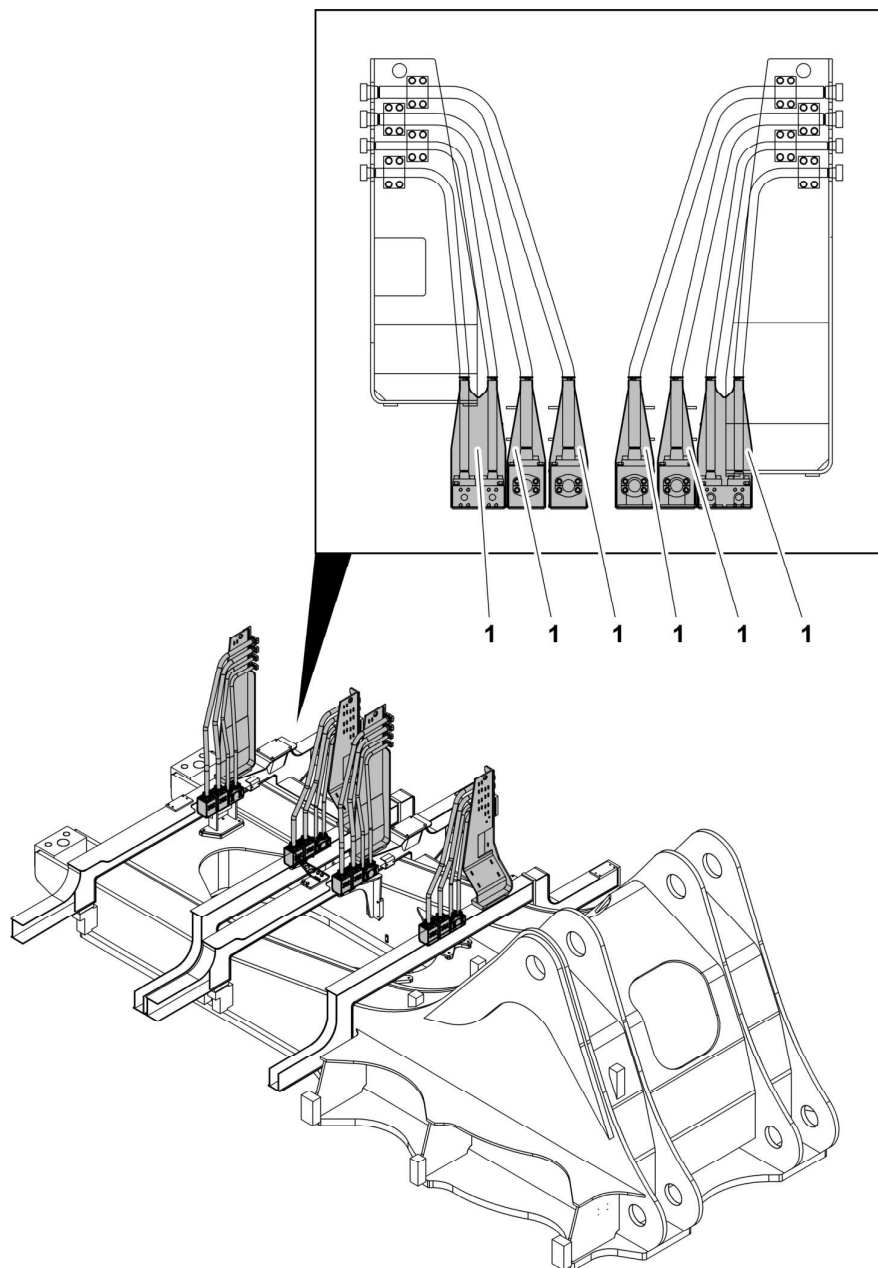

Fig. 5-65 Protective soft shield covers installation

1 Soft shield cover

- ▶ The protective soft shield covers **1** must be inspected and replaced regularly as indicated in the control and maintenance chart.
- ▶ If you find wear or damage on a protective soft shield cover **1**, replace it immediately.
- ▶ If an oil leak occurred which could have sprayed on a soft shield cover **1**, replace the soft shield cover immediately.

nected to the upper section of a swing gear via two hoses).

- ▶ When correct oil level is reached, reinstall the sealing cap 4.

For larger amount:

- ▶ Remove the sealing cap 4 on the expansion tank 7.
- ▶ Add oil via the quick-change coupling 6.
- ▶ When correct oil level is reached, reinstall the sealing cap 4.

Oil level:

The oil level must reach the middle of the lower sight gauge "L" of the expansion tank 7 when the oil is cold, and must not overpass the upper sight gauge "H" when the oil is hot.

5.15.3 Travel gear – oil change



Note!

If possible, drain the oil when the oil is at operating temperature.



Danger!

When the oil is hot, the travel gear elements may be under pressure. Before draining the oil, carefully loosen the oil filling plug 2 to allow the internal pressure to escape.

Each travel gear is equipped with two plugs 2 to check the oil level and to add oil and with two oil drain plugs. One drain plug 3 is mounted to the lower inner section, the second drain plug 5 to the outer ring which rotates with the sprocket.

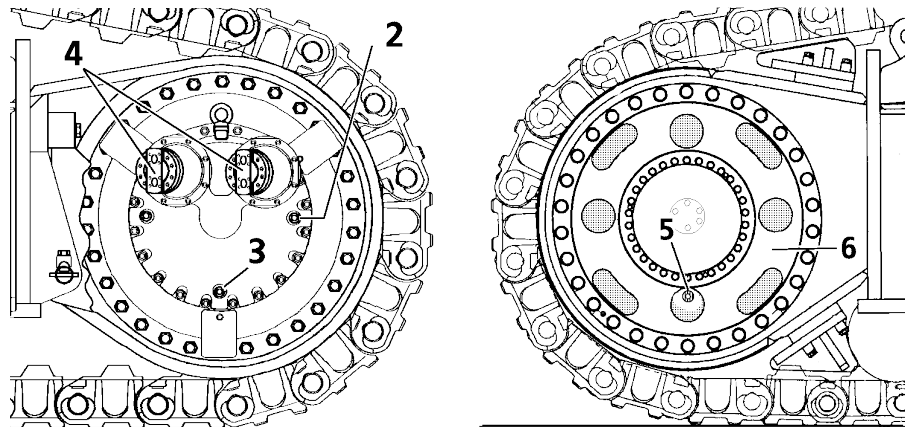

Fig. 5-74 Oil change on the travel gear

- | | |
|-------------------------------|--------------------|
| 2 Oil level and filling plugs | 5 Outer drain plug |
| 3 Inner drain plug | 6 Centering ring |
| 4 Travel motor | |

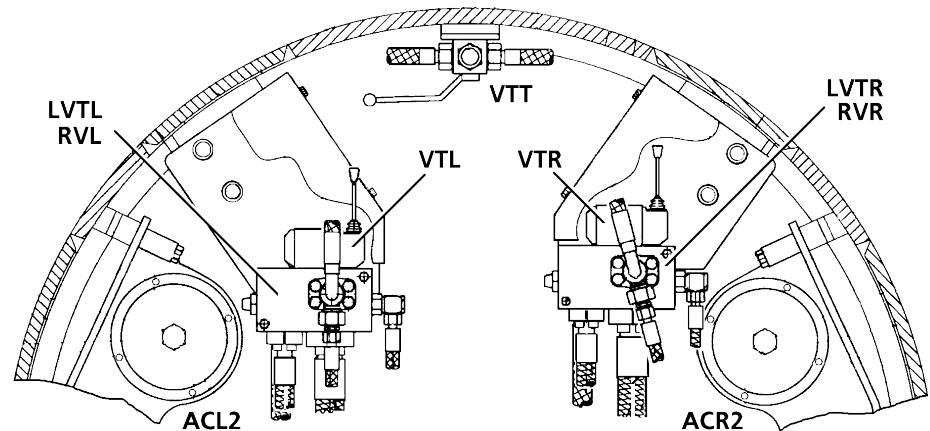

Fig. 5-84 Track tensioning levers

To tension the track

- ❑ Make sure lever(s) **VTL** (left chain) and/or **VTR** (right chain) in the swing ring area is/are closed.
- ▶ Open the track tension tap **VTT**.
- ▶ Start the engine of the excavator.
 - ↳ The chain(s) will automatically be tightened.

To release the track



Danger!

Risk of injury due to sudden pressure relief of the crawler chain.

- ▶ Before attempting to release the chain tension, release and remove every foreign body which may be stuck in the chain while driving forwards and backwards or doing as described in the section "Cleaning the track components" thereafter.
- ▶ Close the tap **VTT** in the swing ring turnet area.
- ▶ Move lever **VTL** or **VTR** to release the track tension pressure on the side you are working on.

5.17.4 Cleaning the track components



Caution!

Do not start the machine up if large stones, pieces of wood or of metal, wires or cables are stuck in the running gear.

Dried or frozen mud as well as stones or other foreign bodies in the travel gear parts could result in considerable damages for the machine if this one is operating or if you try to release the machine using engine power.

has to be replaced by reasons of explosion. While replacing, take care of the mounting direction. The exit is marked with an "A" and the top side is marked with "OBEN".

- ▶ Change the filter/drier **6** in air conditioning unit at regular intervals, at least once a year. The filter/drier **6** also have to be changed after each opening of the refrigerant circuit. The arrow symbols on the filter/drier have to be placed in the direction of the expansion valve.
- ▶ In addition, the refrigerant charge of the system must be checked at regular intervals, by observing the sight glass **7** of the receiver/filter/drier unit while the air conditioning system is operating.
Bubbles or foam in the sight glass **7** indicate an insufficient refrigerant charge.
- ▶ In this case, the system must be checked and refilled by a trained specialist.
- ▶ Check the color of the indicator in the sight glass **7**. If the indicator becomes yellow, it means that there is too much humidity in the system. The filter/drier **6** must be changed immediately by a trained specialist.

5.19.3 Additional maintenance operations

- ▶ Check operation of evaporator blowers and condenser fans. All blowers have to be in working order in order to avoid air short circuit.
- ▶ Check electric installation.
- ▶ Check all hose fittings and couplings for leakage.
- ▶ Check setting, and function of defrosting thermostat at the evaporator coil.
- ▶ Check compressor pressure switch. If the pressure at the compressor on the low pressure side is too high, the compressor pressure switch lights up an indicator lamps. This means that the compressor is not working well.

5.20 Check mounting bolts for tightness

- ▶ The mounting bolts listed below must be regularly checked and retighten if necessary.
- ▶ See control and maintenance chart for check intervals.



Note!

When installing bolts of size bigger than M40 the thread of the screw must be slightly coated with a MoS2 based grease. Also grease the bolt head supporting surface, unless hereafter otherwise specified.

sealed at the works).

- In addition, high pressure hoses, hydraulic lines and bolt connections on the hydraulic system can be replaced.

It should be noted that only original Liebherr replacement parts are to be used.

This is particularly relevant for hoses and hydraulic lines, which must be preassembled at the works. For all other repairs, particularly when dismantling the counterweight, works and dealership fitters are to be consulted.

5.22.2 Welding work on the machine

Welding work on all main components serving the power transmission (such as the chassis frame, rotating platform, equipment parts etc.) may only be carried out by the manufacturer or by an authorized workshop.

- ▶ Disconnect the batteries before starting any electric arc welding work on the machine.
- ▶ Disconnect the connectors of the engine control unit.
- ▶ Always disconnect the negative terminal (-) first and reconnect it last.
- ▶ Switch off the main battery switch!

Nevertheless if welding repair should be done on components which may contain inflammable gases (welded counterweight, hydraulic tank, fuel tank, ...) these components must be previously and sufficiently ventilated with pressurized air to avoid all fire or explosion hazard.



Caution!

If high currents flow through the bearings or sealing elements, these could be burnt.

- ▶ Move the earthing cable of the welding tool as close as possible to the welding surface so that the welding current cannot flow over parts like the swing ring, rotary connection, gears, bushings, bearings, hinges, joints, hydraulic hoses, sockets, rubber parts or seals.

5.23 Control and maintenance chart



Caution!

Careful maintenance can only be carried out when the machine is clean. Visual checks such as crack testing are only applicable on a clean machine.

- ▶ Clean the machine before you start maintenance work (see also the chapter "Servicing the machine safely", sections "Cleaning" and "Crack testing").



Caution!

You must do the weekly additional maintenance tasks. Liebherr recommends that you schedule this maintenance interval carefully.

WORK TO BE PERFORMED AT 250, 750, 1250 HOURS, ...	Check	Initials	Comments
Check <input type="checkbox"/> for first and only interval or Check <input type="radio"/> for repeat interval			
TRAVEL GEAR			
Do a visual check of the gear for leaks, if there are leaks, check oil level	<input type="radio"/>		
UNDERCARRIAGE			
Do a visual check of all parts for damages and cracks If necessary fill out the "Structural Inspection" form in Service Manual - Chapter 4	<input type="radio"/>		
ATTACHMENT			
Do a visual check of the bucket teeth and wear kit for wear	<input type="radio"/>		
Do a visual check of the grease supply at each lube point	<input type="radio"/>		
Do a visual check of cable harness and sensors for damage	<input type="radio"/>		
Do a visual check of all parts for damages and cracks If necessary fill out the "Structural Inspection" form in Service Manual - Chapter 4	<input type="radio"/>		
Do a visual check of the fastening of pin covers	<input type="radio"/>		
Do a visual check of the non-slip surfaces for wear and damage	<input type="radio"/>		
UPPERCARRIAGE			
Do a visual check of mirrors and cameras, clean and adjust if necessary	<input type="radio"/>		
Do a visual check of the service trap for leaks or damage	<input type="radio"/>		
Do a visual check of oil, grease or fuel for leaks	<input type="radio"/>		
Do a visual check of the non-slip surfaces for wear and damage	<input type="radio"/>		
SWING GEAR			
Do a visual check of the swing gears for leaks and oil level in expansion tanks	<input type="radio"/>		
CENTRALIZED LUBRICATION SYSTEM			
Perform a complete daily maintenance given in the LINCOLN Operating Instructions Manual	<input type="radio"/>		
Do a check of the grease tank level	<input type="radio"/>		
DIESEL ENGINE AND SPLITTERBOX			
Do a visual check in and around the engine compartment for leaks, contamination and damage	<input type="radio"/>		
Check engine oil level	<input type="radio"/>		
Sample and analyse engine oil	<input type="radio"/>		
Check oil level in oil reserve system (optional equipment)	<input type="radio"/>		
Check that the monitoring LED of the oil reserve system shows correct operation (optional equipment)	<input type="radio"/>		
Change oil in Diesel engine (if the optional oil reserve system is not installed)	<input type="radio"/>		

LEC/en/Edition: 03 / 2021

WORK TO BE PERFORMED AT 500, 1500, 2500 HOURS, ... Check <input type="checkbox"/> for first and only interval or Check <input type="radio"/> for repeat interval	Check	Initials	Comments
Follow the inspection intervals recommended by the specific Health and Safety rules existing in country and/or on mine site	○		
START THE ENGINE TO CHECK THE FOLLOWING ACTIONS			
General: Maintenance work must include the check of the correct functions of hydraulic and electric systems before starting operation	○		
Attachment: Check function of the working attachment lubrication system during operation	○		
Attachment: Check if the damping system on equipment is working correctly	○		
Uppercarriage: Check position of the hydraulic shut-off valve	○		
Uppercarriage: Check movement and locking of the access ladder	○		
Uppercarriage: Check that the swing movement of the uppercarriage is locked when the access ladder is lowered	○		
Swing Gear: Check function and operation of the swing brake	○		
Swing Ring: Check function of the swing ring bearing lubrication system during operation	○		
Swing Ring: Check function of the swing ring teeth lubrication system during operation	○		
Diesel engine: Check speed on RPM gauge	○		
Diesel engine: Check running noises	○		
Diesel engine: Check exhaust gas colour	○		
Diesel engine: Check oil pressure and coolant temperature during operation	○		
Diesel engine: Check if the prelub system is working properly	○		
Electrical system: Clean and check LCD screen of the display for proper function when starting	○		
Electrical system: Check indicator lights and gauges on the control panel when starting	○		
Electrical system: Check for warning and fault messages on display (monitoring, grease, air conditioning, ...). If necessary refer to chapter 4 in the Operating Manual to identify and rectify faults and errors.	○		
Air pressure system: Do a visual check of cut in and cut out pressure of air pressure regulator	○		
Air pressure system: Do a visual check of hydraulic tank pressure	○		
Cabin: Check if the safety lever is working properly	○		
Cabin: Check the horn	○		
Cabin: Check for green flash light on control module if fire fighting system is installed	○		

LEC/en/Edition: 03 / 2021

5.23.7 2000 Hours Maintenance Schedule - R 996B

Serial Number: Fleet Number: SMU HOURS: Travel Hours:	Completed by : Date and Signature :
--	---

WORK TO BE PERFORMED AT 2000, 4000, 6000 HOURS, ... Check <input type="checkbox"/> for first and only interval or Check <input type="radio"/> for repeat interval	Check	Initials	Comments
GENERAL HYDRAULIC SYSTEM			
Do a visual check of all hoses, pipes and fittings for any external damage or leakage	<input type="radio"/>		
Do a detailed check for good condition of pipes, hoses, clamps and fittings for damage and leakage	<input type="radio"/>		
Do a visual check of the hydraulic components for leaks and/or damages	<input type="radio"/>		
Do a visual check of the hydraulic cylinder rods for leaks and good condition	<input type="radio"/>		
GENERAL FASTENING			
General hydraulic: Do a visual check for missing, broken or loosen mounting screws of all hoses, pipes, fittings and clamps, tighten if necessary	<input type="radio"/>		
Track components: Do a visual check for missing, broken or loosen mounting screws of the sprockets, rollers, idlers, track guides, track pads, protection covers and final drives, tighten if necessary	<input type="radio"/>		
Track components: Do a detailed check for missing, broken or loosen mounting screws of the rollers, pins locking and track guides, tighten the screws	<input type="radio"/>		
Track components: Do a detailed check for missing, broken or loosen mounting screws of the idler axis locking keys, tighten the screws	<input type="radio"/>		
Track components: Do a detailed check for missing, broken or loosen mounting screws of the track pads, tighten the screws	<input type="radio"/>		
Travel gear: Do a detailed check for missing, broken or loosen mounting screws of the gears, sprocket wheels and hydraulic motors, tighten the screws	<input type="radio"/>		
Undercarriage: Do a detailed check for missing, broken or loosen mounting screws of the side frames, tighten the screws	<input type="radio"/>		
Undercarriage: Do a visual check for missing, broken or loosen mounting screws of all parts, tighten if necessary	<input type="radio"/>		
Attachment: Do a visual check for missing, broken or loosen mounting screws of the handrails, pin covers fastening and greases connections, tighten if necessary	<input type="radio"/>		
Attachment: Do a detailed check for missing, broken or loosen mounting screws of the handrails, pin covers fastening and greases connections, tighten the screws	<input type="radio"/>		
Uppercarriage: Do a visual check for missing, broken or loosen mounting screws of the counterweight, tanks, Powerpack, control valve console, cab, cab elevation, catwalks, handrails, grease box, ladder, tighten if necessary	<input type="radio"/>		

LEC/en/Edition: 03 / 2021

LEC/en/Edition: 03 / 2021

6.2 Centralized lubrication system

LEC/en/Edition: 03 / 2021

A. Description of the system as a whole

1	FUNCTION OF THE LUBRICATION SYSTEM.....	2
1.1	DESCRIPTION OF THE ENTIRE SYSTEM.....	2
1.1.1	Standard: 1 Pump variant	2
1.1.2	Option: 2 Pumps variant	2
1.2	SEQUENCE OF A LUBRICATION CYCLE.....	3
1.2.1	Systems 1 and 2:	3
1.2.2	System 3.....	3
1.3	LUBRICATION DIAGRAM	4
1.3.1	Standard: 1 Pump variant	4
1.3.1	Option: 2 Pump variant.....	5
2	OPERATION	6
3	ELECTRONIC CONTROLLER.....	7
3.1	DESCRIPTION OF DISPLAY AND OPERATING ELEMENTS	7
3.2	FAULT SIGNALS.....	10
3.3	ADJUSTED VALUES	10
3.4	PAUSE-TIME ADJUSTMENT.....	11
4	INSPECTION AND MAINTENANCE.....	12
5	TOPPING UP GREASE RESERVOIRS	13
5.1	P1 AND P2: FILLING OF THE CONTAINER	13
6	MALFUNCTIONS AND THEIR REMEDY	14

3.4 Pause-time adjustment

The operator may also use the control unit in the driver's cab to adjust the lubricant volume following the adjusting range given in chapter 3.2 in order to quickly react to poor or excessive lubrication.

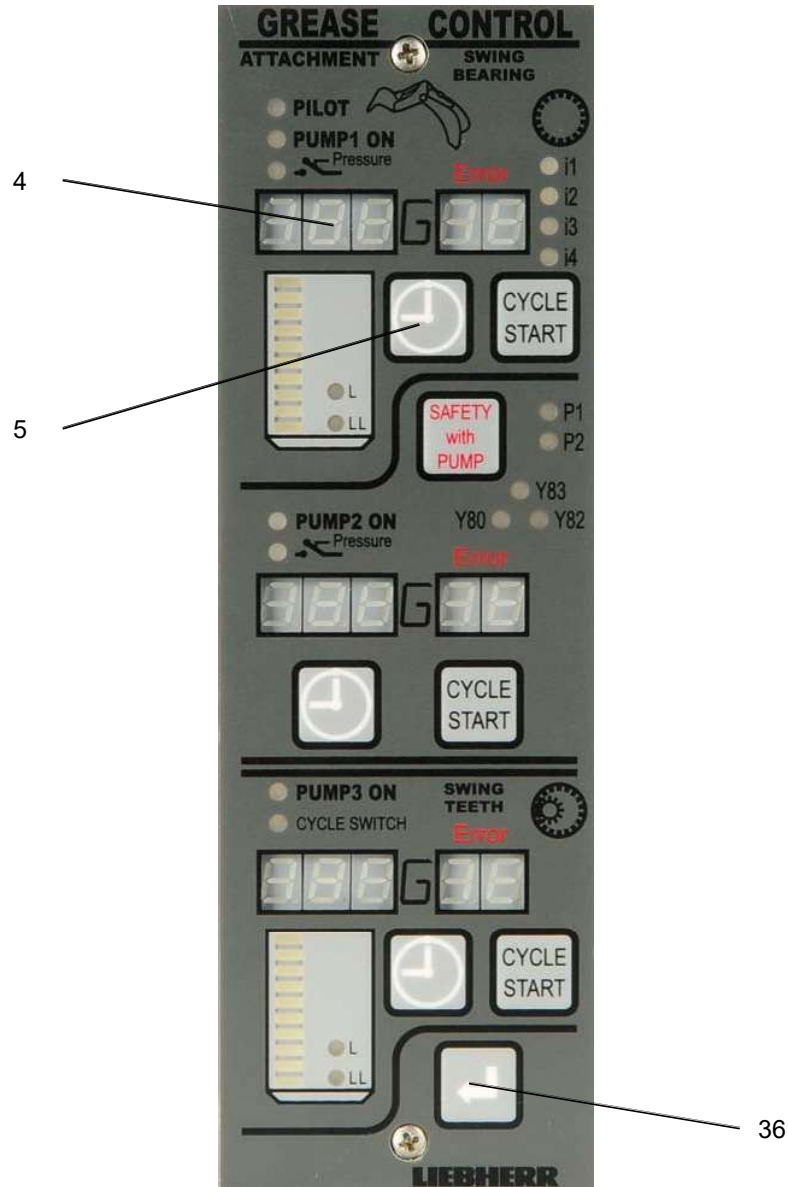

If **key 5** is pressed > 5 sec, the controller will change into the setup mode and the adjusted pause time will be indicated by a flashing mode in **display 4**.

Pressing the key in the setup mode < 5 sec increases the pause time by one second.

Pressing the key in the setup mode > 5 sec increases the pause time in increments of 5 sec continuously as long as the key is being pressed.

If in the setup mode *no key is pressed* during 20 sec, the former pause time setting will be taken and the setup mode will be quit.

When pressing the *Enter key* (36) the newly adjusted pause time will be adopted and the setup mode will be quit.

CLICK HERE TO **DOWNLOAD** THE COMPLETE MANUAL

- Thank you very much for reading the preview of the manual.
- You can download the complete manual from: www.heydownloads.com by clicking the link below



- Please note: If there is no response to CLICKING the link, please download this PDF first and then click on it.

CLICK HERE TO **DOWNLOAD** THE COMPLETE MANUAL