

Operating manual

Hydraulic excavator
R 9200

from serial number 40083

Document identification

ORIGINAL MANUAL

Order number: 12269252
Edition: 03 / 2021
Valid for: R 9200 from serial number 40083
Author: LEC - Technical documentation department

Product identification

Manufacturer: Liebherr-Mining Equipment Colmar SAS
Type: R 9200
Type no.: 1625

Address

Liebherr-Mining Equipment Colmar SAS
49 rue Frédéric Hartmann
CS 50038, F-68025 Colmar Cedex

CLICK HERE TO **DOWNLOAD** THE COMPLETE MANUAL

- Thank you very much for reading the preview of the manual.
- You can download the complete manual from: www.heydownloads.com by clicking the link below



- Please note: If there is no response to CLICKING the link, please download this PDF first and then click on it.

CLICK HERE TO **DOWNLOAD** THE COMPLETE MANUAL

1 Product description

1.1 Overview

1.1.1 Machine

Machine with backhoe attachment

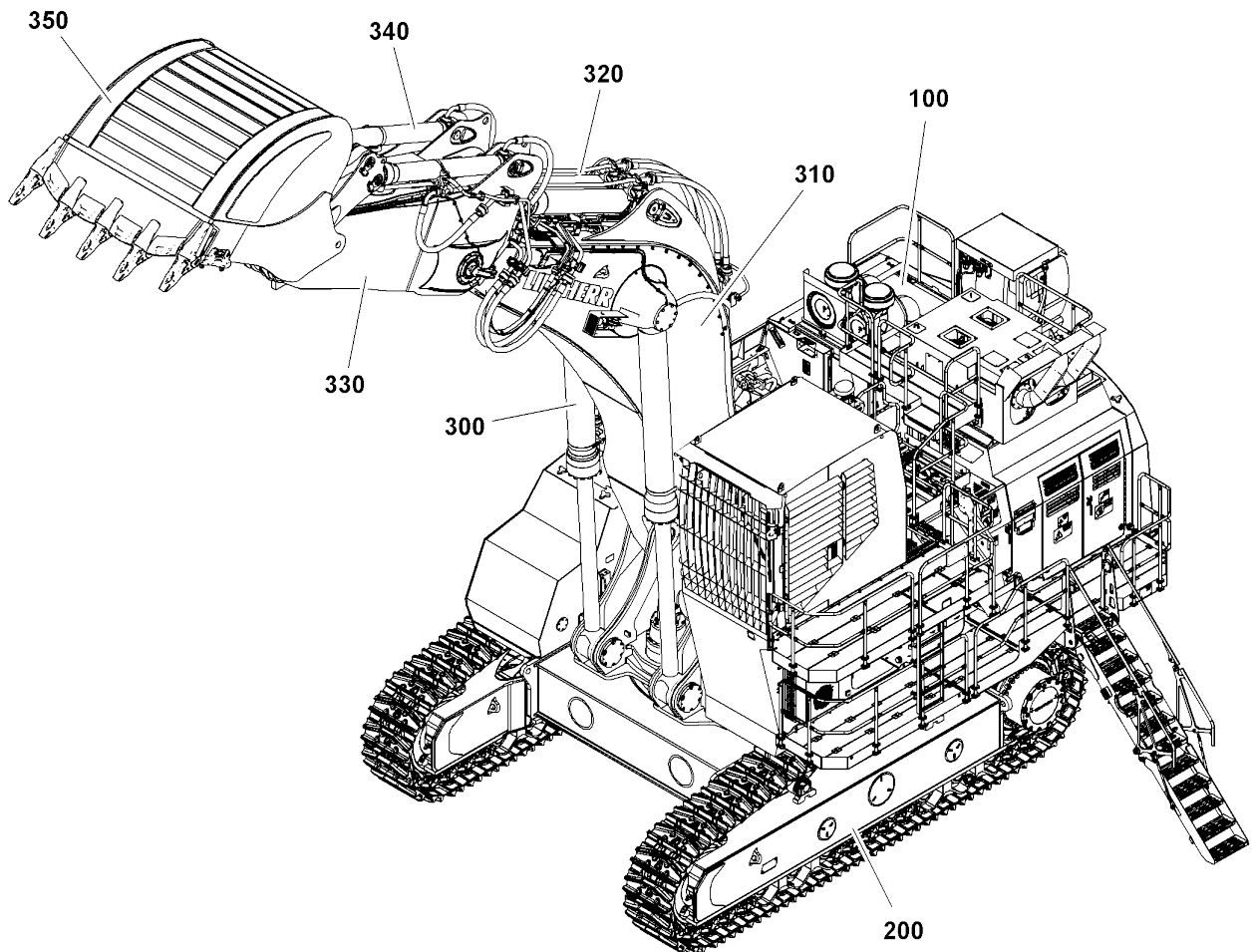

Fig. 1-1 Machine with backhoe attachment

- | | | | |
|------------|---------------|------------|----------------------|
| 100 | Uppercarriage | 320 | Stick cylinder |
| 200 | Undercarriage | 330 | Stick |
| 300 | Boom cylinder | 340 | Bucket tilt cylinder |
| 310 | Boom | 350 | Bucket |

Fast and Precise Movement

Proven Mining Engine

The R 9200 is powered by a single Cummins QSK38 diesel engine which is US EPA Tier 2 or US EPA Tier 4f/EU Stage V compliant. Renowned for its reliability, the engine delivers durable and superior performance contributing to achieve production goals. Liebherr's deliberate choice of the proven Cummins engine is due to the efficient proactive service on-site and continued collaboration with Cummins.

Easy Machine Control

The R 9200 is designed with user friendly controls featuring an advanced electronic piloting system, which promotes an intuitive and versatile control resulting in increased productivity.

Fast Cycle Time

Like all other Liebherr mining excavators, the R 9200 uses a closed-loop swing circuit. The main hydraulic circuit comprises a combination of four independent main valves fed by four working pumps, providing unrivalled flexibility of attachment control and force distribution, while allowing full oil flow integration for fast movement and lowest cycle times.



Single Driveline Concept

- Cummins QSK38 US EPA Tier 2 or US EPA Tier 4f/EU Stage V compliant
- Automatic idling system and engine shutdown
- Fuel pre-filter with water separator
- Max. altitude without deration: 3,600 m
- Fuel consumption optimized setting (optional)

Exclusive EVO Bucket Solution

- Liebherr patented EVO design to maximize the loading capacity
- Optimized Liebherr GET and wear package according to customer application
- Ensures optimal penetration efficiency
- Single GET hammerless locking system for safe and easy maintenance
- Fully patented GET system design for optimal penetration / lifetime
- 4 tooth profiles available for various range of applications

Ergonomic Cab Design

- Elevated and armored cab installation
- User-friendly piloting station
- Screen located for convenient operator viewing
- Passenger seat for trainer, mechanical engineer or geologist
- Additional protection offered

Cab Optimized for Performance

Accessibility, comfort and safety define the standard of the new Liebherr cab for the R 9200. A panoramic view combined with cameras system allow the operator to have in any case the control of the working environment. The seat, joysticks and pedals are designed and located to increase the result of the operator while reducing fatigue.

Highest Digging and Breakout Force

As a result of the highest digging and breakout forces in its class, the R 9200 provides fast and efficient filling of the bucket, even in extreme digging conditions.

Minimized Impact on Life

Optimized Energy Consumption, Fewer Emissions

The intelligent energy management system coordinates optimal interaction between the hydraulic system and engine output with the goal of maximum performance with minimum fuel consumption. "Eco-Mode", the machine is set up to reduce engine load, improve significantly fuel consumption and optimize emissions.

Controlled Emission Rejection

The R 9200 is powered by a high horsepower diesel engine which complies with the US EPA Tier 2 or US EPA Tier 4f/EU Stage V compliant emission limits. This power drive makes the R 9200 cost effective without compromising productivity and also reduces impact on the environment.

Sustainable Design and Manufacturing Process

Certified Environment Management Systems

Subject to the stringent European program for the regulation of the use of chemical substances in the manufacturing process REACH*, Liebherr undertakes a global evaluation to minimize the impacts of hazardous material, pollution control, water conservation, energy and environmental campaigns.

Extended Components and Fluids Lifetime

Liebherr is constantly working on ways to extend component life. Through the Remanufacturing Program, superior lubrication systems and the reinforcement of parts under stress, Liebherr can reduce frequency of part replacement. The result minimizes environmental impact and lowers the overall cost of ownership.

*REACH is the European Community Regulation on chemicals and their safe use (EC 1907/2006) It deals with the Registration, Evaluation, Authorization and Restriction of Chemical Substances.



The Liebherr-Mining Remanufacturing Program

- Reduced environmental impact
- Second life for your components
- Alternative to purchase brand-new replacement components
- Liebherr certified workshops

Eco-Mode

The Eco-Mode can be manually selected by the operator when maximal power is not required according to job need for:

- An improved fuel efficiency
- Less load on the engine
- Less noise pollution
- Less dioxide carbon emissions

Sustainable Manufacturing Process

- Promoted recovery-waste management
- Controlled non-recyclable waste elimination
- Eco-friendly material selection (95 % of material used on machine is recyclable)
- European certifications

2.3 Safety Instructions

General safety instructions

- Please familiarize yourself with the operating instructions before starting up the machine.
- Ensure that you have obtained, read and understood any additional instructions relating to special accessories for the machine.
- Only specifically authorized persons may operate, maintain or repair the machine. The legal minimum age is to be adhered to.
- Only employ trained or appropriately instructed personnel. Clearly establish which personnel are responsible for operating, setting up, maintaining and repairing the machine. Give personnel the power to refuse to carry out unsafe instructions. This also applies in relation to traffic regulations.
- Only permit apprentices and personnel who are in training or who have only general training to operate on the machine under the constant supervision of an experienced member of staff.
- As far as possible, monitor personnel to ensure that they are adhering to safe working practices, are aware of risks and are observing the operating instructions.
- Always wear safe work clothes when you are working on or with the machine. Avoid wearing rings, wrist watches, ties, scarves, open jackets, baggy clothing etc... There is a risk of injury from, for example, getting caught up or being drawn in.
- Wear individual protective equipment (protective goggles, safety helmets, safety shoes and gloves, reflective vests and ear protection etc...).
- Ensure that you obtain information on any special safety regulations for the job site from the site foreman.
- Always tilt up the safety lever before leaving the operator's seat.
- When getting in and out, do not hold on to the steering column, control panel or joystick. Doing this could cause unintentional movement, which could result in an accident.
- Never jump from the machine; use the steps, ladders, gangplanks and supporting straps provided for this purpose.
- Face the machine when getting in or out and always use three-point support, i.e. two hands and one foot or two feet and one hand must always be in contact with the access system at the same time.
- Familiarize yourself with the location of the emergency exit.
- In the absence of any other instructions, proceed as follows for all maintenance and repair work:
 - park the machine on firm, level ground
 - align the uppercarriage with the undercarriage so that the sprockets locate at the back-end
 - anchor the bucket in the ground.
 - place all operating levers into neutral and tilt the safety lever up.
 - switch off the engine and remove the start key.
- Before touching any parts of the hydraulic circuits, you must also operate all pilot control devices (joystick and pedals) in all directions with the start key in contact position and with the security lever lowered, in order to reduce the actuating and dynamic pressures in the work circuits. You must then reduce the internal tank pressure as described in these operating instructions.
- Secure all loose parts on the machine.
- Never operate a machine before carrying out a careful inspection tour and checking whether any warning signs are missing or illegible.

- The machine can still sway and tilt despite being aligned!
The following instructions are therefore to be observed at all times:

When moving the machine:

- Rotate the uppercarriage parallel to the undercarriage (transport position).
- Draw the attachment as close as possible to the machine.
- Only at this point may the support feet be retracted and the machine moved.
- Moving with loads is not permitted.
- Check the terrain to be covered to ensure that the ground is solid and even. Potholes and uneven surfaces jeopardize the stability of the machine.
- Adjust vehicle handling to suit the altered machine characteristics (high centre of gravity) and environmental conditions.
- Reduce your speed to prevent the need for sudden braking and steering manoeuvres.
- Avoid sudden speed changes, such as braking, accelerating and changing direction.
- Ascending gradients and obstacles may only be approached in the longitudinal direction in order to prevent unacceptable banking of the machine.
- Special care should be taken when driving through narrow passages - drive slowly!

When loading and unloading:

- The machine must be supported and aligned horizontally before moving (swing) the uppercarriage out of the transport position.
- It is imperative that you check the contact surface of the support (load carrying capacity of the substrate). A support subsiding would have disastrous consequences!
- Carry out all movements with increased care.
- To slew the load, move the attachment as close as possible to the machine (**Caution! swinging grab**) and hold the load close to the undercarriage and above the substrate.
- Avoid braking or accelerating the attachment or uppercarriage abruptly.
- Do not lift any loads which are heavier than those given in the load chart.

Protection from vibration

- Vibrational loads on mobile building machinery are mainly the result of the type and method of use. The following parameters in particular are decisive influences:
 - Terrain conditions: Uneven areas and potholes;
 - Operational techniques: Speed, steering, brakes, controlling the machine's control elements when driving and working.
- To a large extent, the machine operator determines the vibrational loads since he selects the speed, gearbox ratio, working method and route himself.
This means that there is a wide range of different vibrational loads for the same machine type.

Whole-body vibrational load for the machine operator can be reduced if the following recommendations are observed:

- Select suitable machines, attachment parts and auxiliary devices for each part of the job.
- Use a machine that has a suitable seat (i.e. for earth-moving machinery such as hydraulic excavators, this should be a seat which corresponds with EN ISO 7096).
- Keep the seat in good condition and adjust it as follows:
 - The seat and its damping action should be adjusted depending on the weight and height of the operator.
 - Check the seat's damping action and adjustment mechanisms regularly and ensure that these seat characteristics remain as per the seat manufacturer's in-

ber must be provided when ordering spare parts.



Danger!

Non-observance of **safety plates** can result in serious injury or death.

- ▶ Check warning plates regularly to ensure that they are complete and clearly legible.
 - ▶ Replace missing or illegible safety and information plates immediately. You will find the ordering numbers of these plates in the spare parts book of the excavator.
-

3 Control and operation

3.1 Operating and control elements

3.1.1 Overview of the control cab

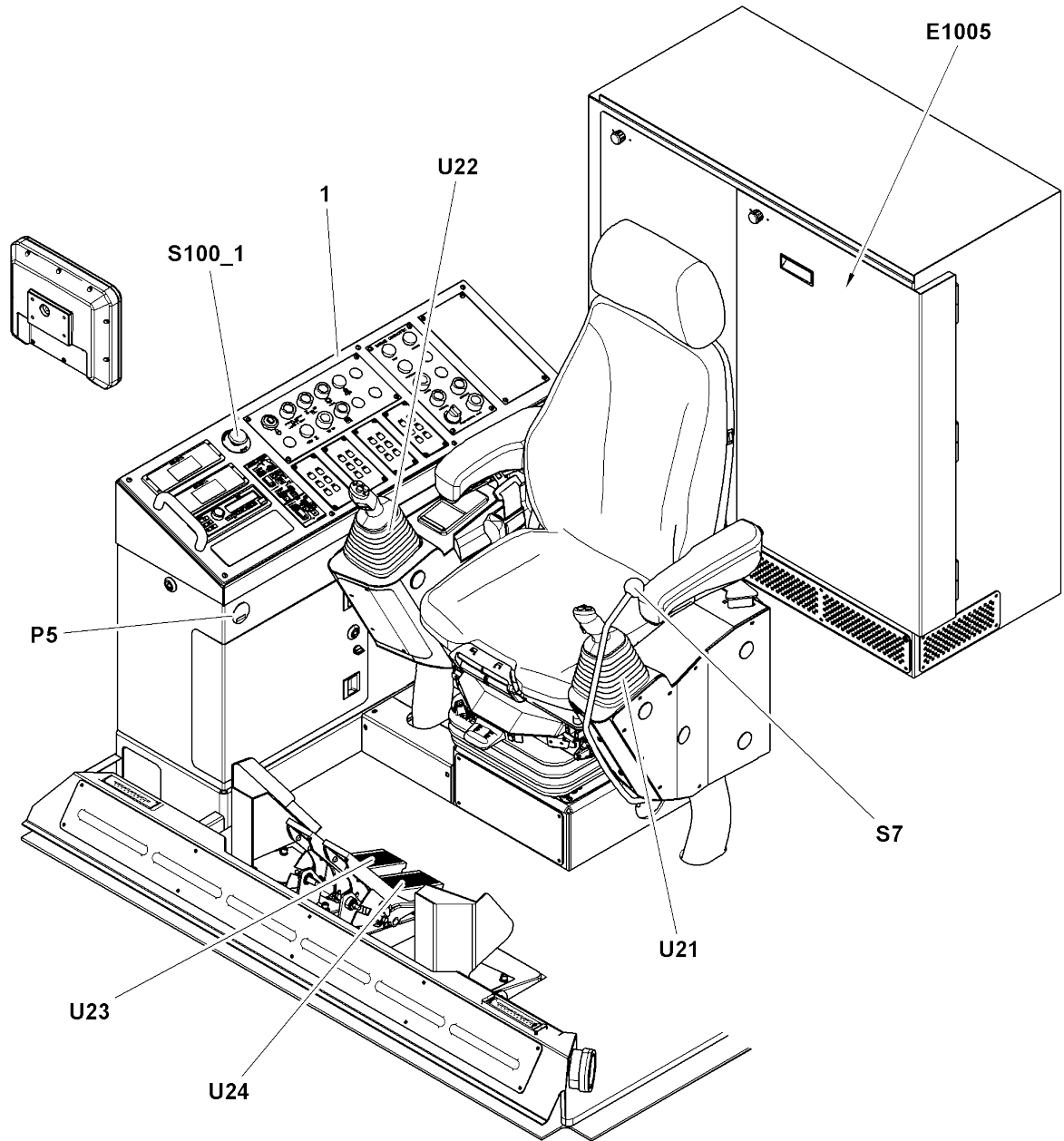

Fig. 3-1 Control cab

LEC/en/Edition: 03 / 2021

3.1.4 Cab control board

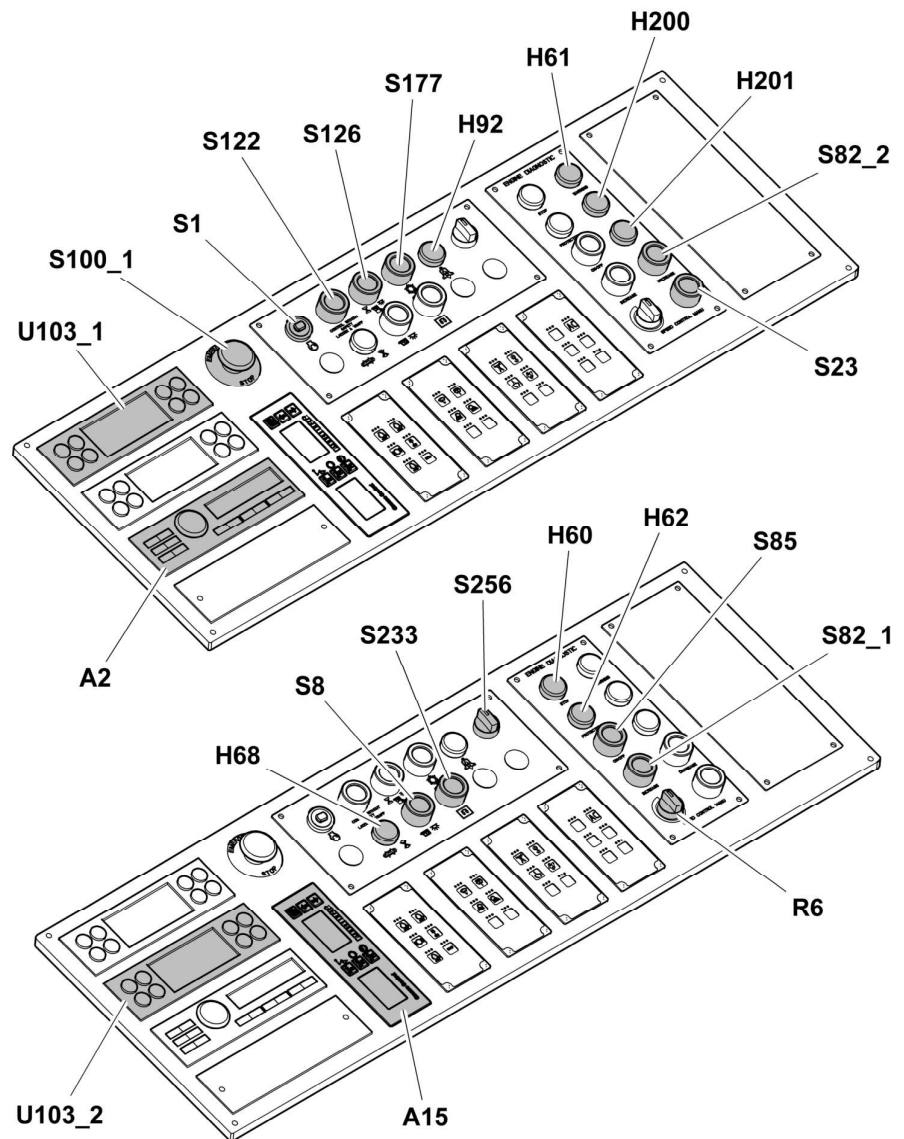

Fig. 3-6 Cab control board

A2	Radio	S23	Diesel engine safety operation ON
A15	Control unit for the centralized lubrication system	S82_1	Diagnostic increment
H60	STOP indicator	S82_2	Diagnostic decrement
H61	WARNING indicator	S85	ECM monitoring ON/OFF
H62	MAINTENANCE indicator	S100_1	Emergency stop
H68	Trap control lock	S122	Disable access ladder or trap control lock
H92	Fire alarm (optional)	S126	External cab lighting

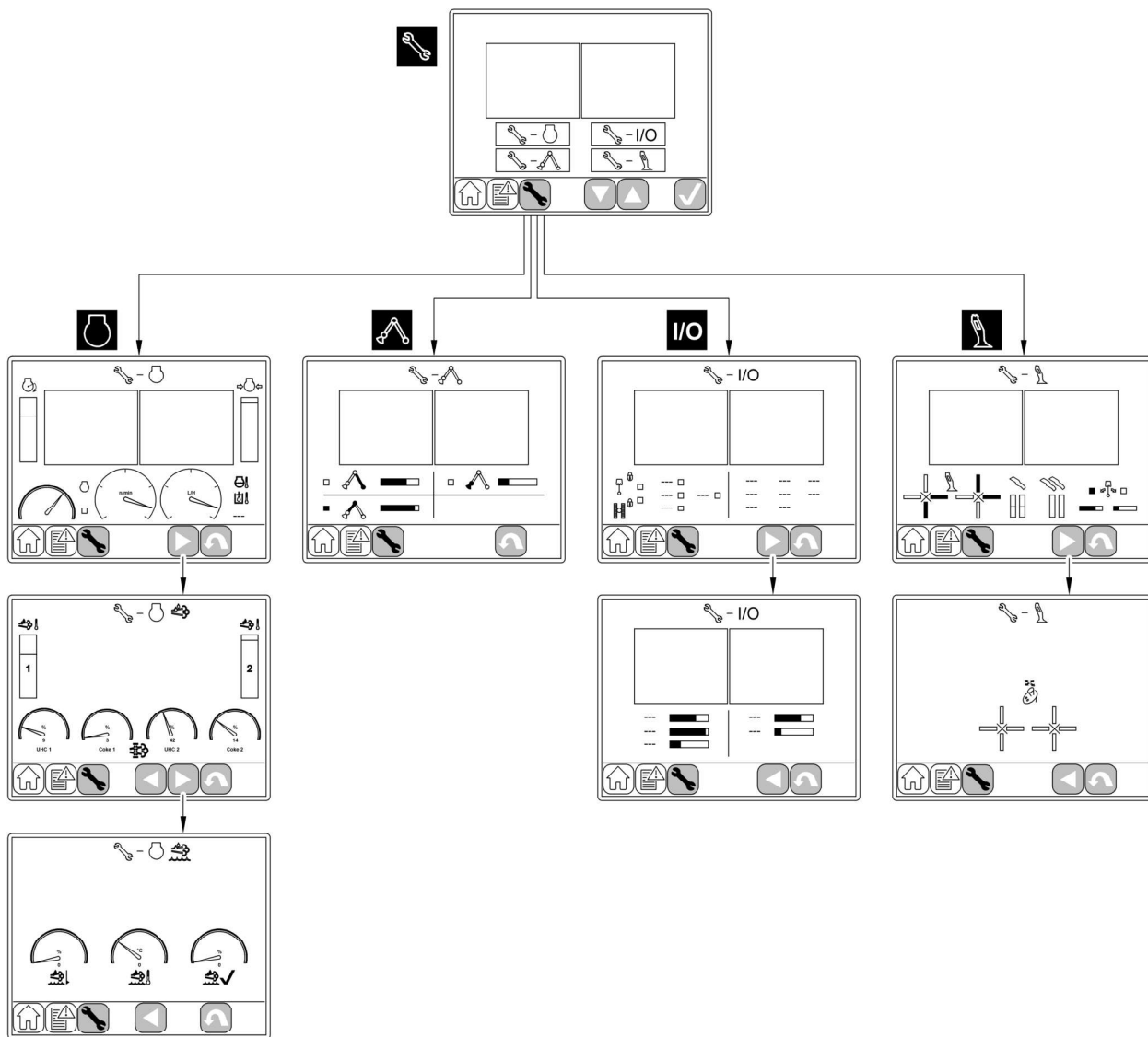



Fig. 3-15 Submenus of the menu "Check"

Submenus:

- Engine**



This submenu shows in real time different parameters values of the engine.

- Inputs Attachment**



This submenu shows the status of digital and analogical inputs of the machine attachment.

LEC/en/Edition: 03 / 2021

Submenus:

Time



This submenu is used to set the time.

Auto idle control



This submenu is used to set the auto idle interval of the auto idle function.

Wiper



This submenu is used to set the wind-screen wiper interval.

Brightness



This submenu is used to set the luminescence of the display.

Language



This submenu is used to set the language in which the error codes are written.

Set a parameter

From each submenu of the menu "**Settings**":

- ▶ Push the safety lever up.



- ▶ Push the "**Up**" and "**Down**" buttons to select the parameter to set (time, value or language).



- ▶ Push the "**Accept**" button to record the new parameter.

Submenu "Time"



You can also use this submenu to switch from summer to winter time (and back again).

- ▶ Push the "**Daylight**" button.

↖ This symbol is transparent when the time difference of an additional hour is deactivated.

↖ This symbol is green when it is activated.

- If you wish to work with the door open, it is necessary to fasten your safety belt. If unavailable, let it be installed before working with the door open.
- For cab with a rear door:
 - Now continue to climb up, still using the three-point support and close the door as soon as you enter the cab.
 - Sit down in the operator's seat and fasten the safety belt (if available) before tilting down the safety lever, and start the machine.

Safely getting down

- Proceed with the same precautions to climb up or down onto the machine, as to install yourself.
- Stop the machine on level, horizontal ground. The upper structure should be positioned with the undercarriage in such a way that the steps and ladders are aligned with each other.
- Open and lock the door. Be sure of it's locking. Take care of weather conditions ! Unfasten the safety belt.
- Position yourself with your face toward the machine when getting out and use three-point support, i.e. two hands and one foot or two feet and one hand must always be in contact with the access system at the same time. Climb down until you can close the doors safely. Always use your hand for control when closing the doors. Lock the door.
- Now climb down to the ground.

3.2.1 Enter or leave the cab

Climb up



Caution!

Entering or leaving the cab incorrectly could lead to injury.

- ▶ Proceed with the same attention on exit or entry of the cab, as while climbing the machine.
- ▶ Ensure that the safety lever is always in its highest position when entering or leaving the cab.
- ▶ Always use the handholds provided for the purpose when entering or leaving the machine.
- ▶ Face the machine when getting in or out and always use three-point support, i.e. two hands and one foot or two feet and one hand must always be in contact with the access system at the same time.
- ▶ Never use the control elements as handles.
- ▶ Never jump from the machine.

Height adjustment

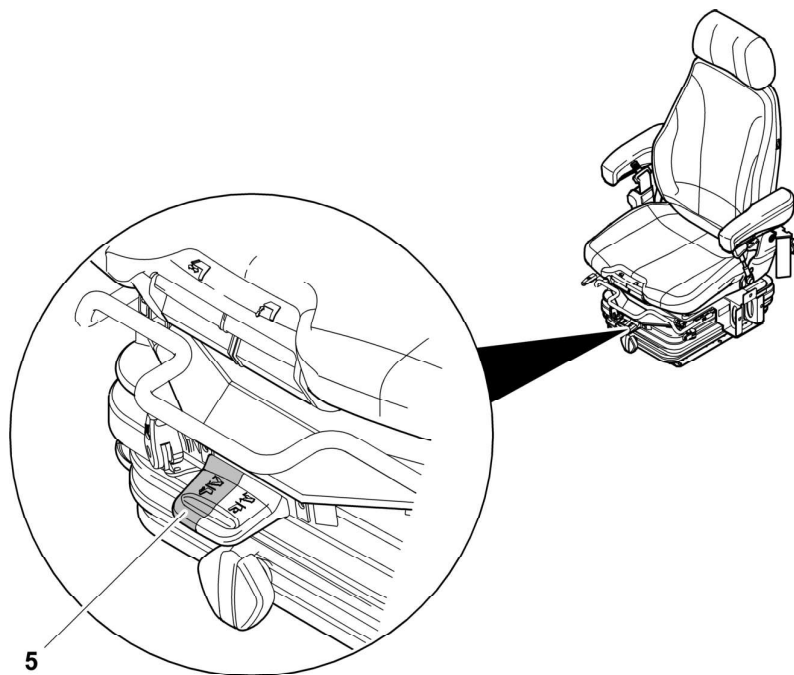

Fig. 3-30 Setting the height

The seat height can be set pneumatically and is continuously adjustable.

To adjust the seat height:

- ▶ Pull the lever 5 up or down.



Caution!

Before adjusting the height, adjust shock absorbers to the position «soft».

3.2.9 Windscreen

Windscreen wiper

Operate the windscreen wiper



- ▶ Make sure that the ignition key is switched to on.
- ▶ Push the button.
 - ↖ Intermittent mode is activated.
 - ↖ First LED in the button comes on.
- ▶ Push the button again.
 - ↖ Continuous mode is activated.
 - ↖ First LED in the button goes off.
 - ↖ Second LED in the button comes on.
- ▶ Press the button a third time.
 - ↖ Windscreen wiper is switched off.
 - ↖ LED in the button goes off.

Set the interval time for the intermittent switching

You can set the interval in the submenu "Wiper" of the monitoring display.

Windshield washer installation

Operate the windshield washer

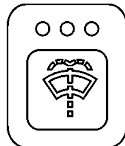

- ▶ Make sure that the ignition key is switched to on.
- ▶ Push and hold the button.
 - ↖ Washing water is sprayed onto the windscreen through the outlet nozzles.
 - ↖ Windscreen wiper runs continuously.
 - ↖ First LED in the button comes on.
- ▶ Release button.
 - ↖ First LED in the button goes off.
 - ↖ Washing water is stopped.
 - ↖ Windscreen wiper finish its cycle.

Second air-conditioning (optional equipment)

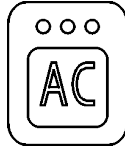

When you start the machine, the automatic second air-conditioning system is operated by default. The two air-conditioning units are working alternately.

The first LED and the second LED in the "Dual air conditioning" button of the control keyboard illuminate.

- ▶ Press the "Second air-conditioning" button.
 - ↖ Automatic air-conditioning mode is deactivated.
 - ↖ First air-conditioning unit is operated.
 - ↖ Second air-conditioning unit is deactivated.
 - ↖ First LED in the button comes on.
 - ↖ Second LED in the button goes out.
- ▶ Press the button again.
 - ↖ First air-conditioning unit is deactivated.
 - ↖ Second air-conditioning unit is operated.
 - ↖ First LED in the button goes out.
 - ↖ Second LED in the button comes on.
- ▶ Press the button again.
 - ↖ Automatic air-conditioning mode is operated again.
 - ↖ First LED and second LED in the button come on.

3.3 Setting the machine into operation

Bringing the machine safely into service

- Carry out a careful inspection tour around the machine each time before starting it.
- Ensure that no one, except an authorized person, is in the work and movement area of the machine.
- Check the machine for loose bolts, cracks, wear, leakage and damage.
- Never attempt to operate a damaged machine.
- Ensure that any damage is immediately rectified.
- Ensure that all hoods and covers are closed, but that locks are unlocked, to facilitate the fight against fire in case of.
- Ensure that all warning signs are present.
- Keep windows and interior and exterior mirrors clean. Secure doors and windows against unintended movement.
- Ensure that no one is working on or under the machine and warn personnel in the vicinity of the machine that it is about to start by sounding the horn.

Adjusting the operator's standing position

- Before starting the machine, adjust the seat, mirrors, armrests and operator's controls in such a way that you are able to work comfortably and safely.
- Acoustic insulation devices on the machine must be set to the insulation position throughout operation.

Protection from vibration - seat adjusting

- Keep the seat in good condition and adjust it as follows:
 - The seat and its damping action should be adjusted depending on the weight

Stop the Diesel engine



Caution!

The engine could be damaged.

- ▶ Do not switch off the engine suddenly from full throttle.



- ▶ Push the "Start/Stop" engine button on the keyboard.
 - ↪ The engine turns at minimum speed during 180 seconds.
 - ↪ The right LED in the button and the related symbol on the display flash.
- ▶ Turn the ignition key **S1** to position "0" to switch to off the machine.
 - ↪ Then the engine stops. The right LED and the display symbol are on.
 - ↪ The right LED goes off.
- ▶ Remove the ignition key **S1**.

3.3.2 Selective Catalytic Reduction (SCR) system

The Selective Catalytic Reduction (SCR) system decreases the nitrogen oxides (NOx) emissions in the exhaust gases. It operates with Diesel Exhaust Fluid (DEF).

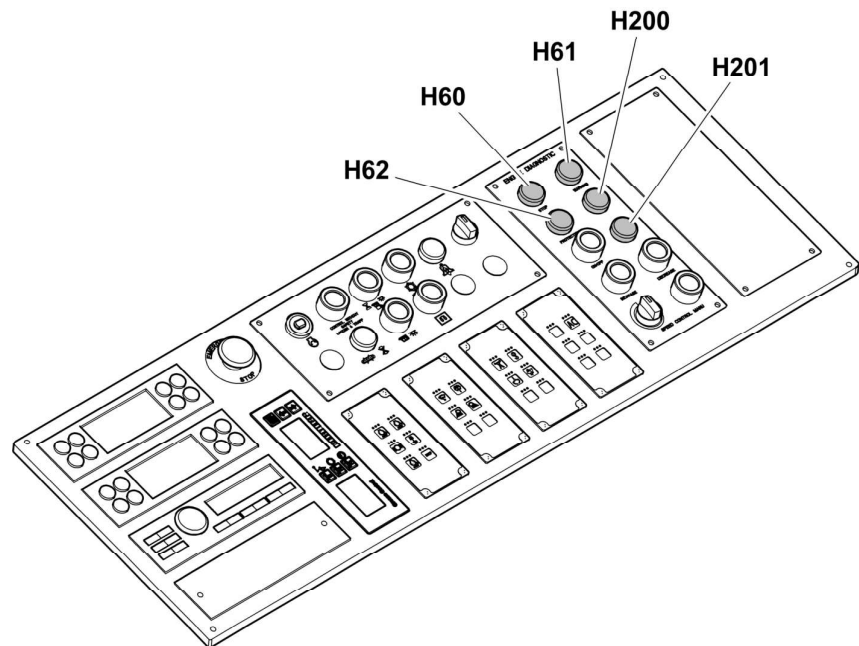
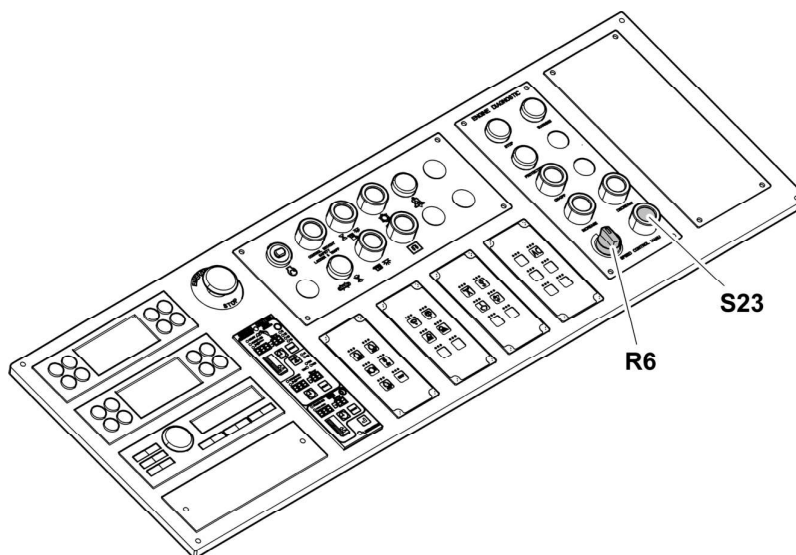

Fig. 3-50 Indicators for Diesel Exhaust Fluid (DEF) and Selective Catalytic Reduction (SCR) system on control board

H60	STOP indicator	H200	Indicator for level of the Diesel Exhaust Fluid (DEF)
H61	WARNING indicator	H201	Indicator for Selective Catalytic Reduction (SCR) system cleaning
H62	MAINTENANCE indicator		

LEC/en/Edition: 03 / 2021

Safety control of the Diesel engine speed**Fig. 3-58** Safety controls for the Diesel engine speed**R6** Speed adjustment of the Diesel engine**S23** Diesel engine safety operation ON

- ▶ Make sure that the safety start of the Diesel engine is on.
- ▶ Push the button **S23**.
 - ↳ The indicator light in the button comes on.
- ▶ Turn the knob **R6** clockwise to increase the engine speed.
- ▶ Turn the knob **R6** counterclockwise to decrease the engine speed.

↳ When you use this mode, this symbol "**Speed control off**" is shown on the display.

**Safety stop of the Diesel engine****Caution!**

Do not suddenly turn the engine off when it is running at high idle.

- ▶ Decrease the Diesel engine speed to low idle with the knob **R6**.
- ▶ Let the Diesel engine run at low idle for 3-5 minutes to decrease the temperature.
- ▶ Then turn the ignition key **S1** to the position "0" and remove it.

- Make sure that the working conditions are in the specified limits.
- Make sure that the special safety devices necessary for the task operate correctly.
- Always obey the applicable local regulations.

Incorrect use of the machine used for demolition application

- Demolition works must be carried out only by trained specialist personnel.
- Do not operate the machine if the counterweight is not suitable for the attachment or special tool you use.
- Do not operate the machine if applicable and approved operator protective structures (e.g. FOPS, front protective grid) are not installed.
- Do not move suddenly and jerkily.
Do not stop it suddenly.
Always move the attachment or special tool slowly and with constant speed movements.
- Because of the possible effects on the machine stability, reduce the height and the speed of the movement.
- Do not lift the machine with the attachment or special tool.
- Make sure that there is no rubble on the attachment or special tool.
- Operate the machine in the position that follows:
 - Align the uppercarriage with the undercarriage so that the sprockets locate at the back-end.
 - Work over the idler.
- Keep a sufficient distance between the machine and the object to demolish.
- Do not use the inertia of the attachment or special tool as an additional force.
- Never leave the machine unattended while the attachment or special tool is not safely positioned on the ground.
- Lay down the attachment or special tool on the ground to park the machine.
- Obey the symbols shown on the display and the acoustic warning signals.
- Prevent unwanted lateral forces on the attachment or special tool when the uppercarriage turns.
- Do not drive at a right angle to the slope.

Incorrect use of the attachment or special tool used for demolition application

- Make sure that you use an attachment or special tool exclusively designed for the task.
- Only use attachment or special tool approved by Liebherr.
- Only operate the attachment or the special tool with closed windshield and with a front protective grid.
- Only operate the attachment or the special tool with closed door.
- Do not clean the ground with the special tool.
- Make sure that the special tool works in its specified limits. For more information, also refer to the Operator's Manual of the tool manufacturer.

Safe use of a hydraulic hammer or a hydraulic ripper

- According to the severity of the application, the use of a hydraulic hammer or a hydraulic ripper can result in vibrations, shocks or stresses which are higher than in normal use. It may reduce the expected lifetime of structures and/or components.

- ↖ Bucket will be tilted inwards.
- ▶ Move the joystick to the right f.
- ↖ Bucket will be tilted outwards.

Shake the bucket (with backhoe attachment only)

You can shake the bucket to remove dirt collected in the backhoe bucket.

- ▶ Operate very quickly the right joystick **3** as follows:
 - Move the joystick fully to the right or to the left.
 - Move the joystick to the neutral position.
 - Move the joystick fully to the right or to the left again.
- ▶ While you do this sequence, the bucket shakes.



Caution!

Repetitive shakings cause fast wear of the components.

Operating the bottom dump bucket for shovel attachment



Danger!

Additional operating and control elements (joysticks/pedals) can have different functions.

- ▶ Always check functions of operating and control elements when you start a machine which has an additional attachment.

Manual flap control

You can control the bottom dump shovel bucket with the pedal or with the joystick.

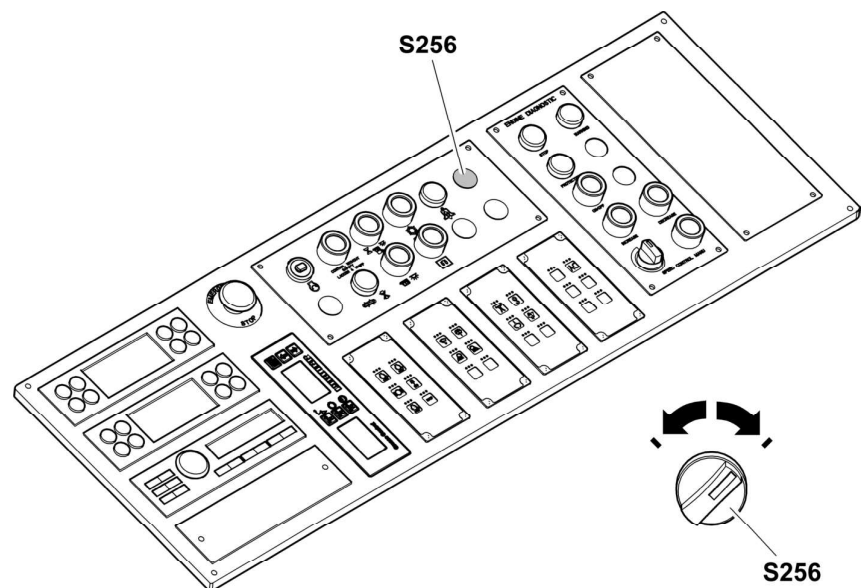

Fig. 3-73 Rotary switch for control selection

- ▶ Use the rotary switch **S256** to select one of the two control modes:
 - with the pedal

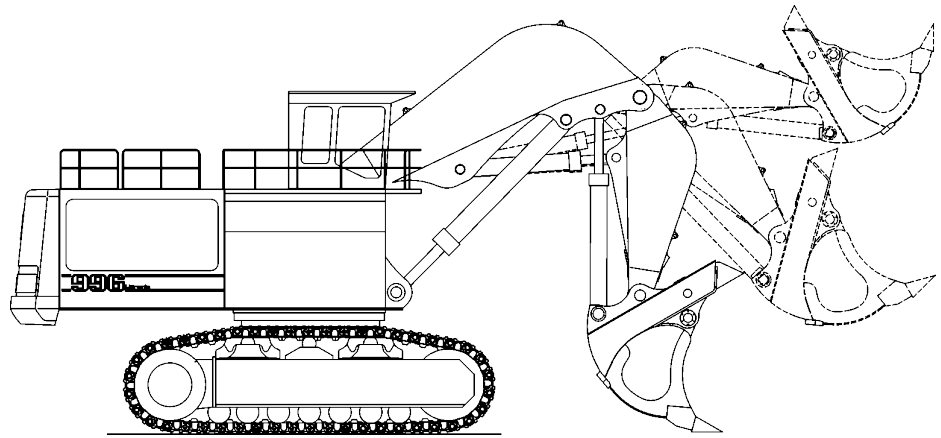

Fig. 3-87 Digging

- ▶ Most digging should be started with the bucket almost fully crowded back (50mm off stops or end of cylinders).
- ▶ When cleaning up or digging at floor level, angle the teeth aggressively to break out any toe that may be encountered.
- ▶ Keeping the heel of the bucket off the ground therefore creating a void under the rear of the bucket.
- ▶ Operate with the teeth and bucket lip doing all the work.



Note!

Avoid digging at right angles to the tracks.



Caution!

- ▶ Each time the stick is crowded back to commence a cut, extreme caution must be taken not to hit the tracks.
- ▶ The clam must always be closed when digging, although don't slam it shut. Avoid working on the cylinder limits and bucket stops during the digging cycle. Continual use of these practises will lead to premature failure of seals and O-rings and can cause stress fractures to the clam, stick and bucket and damage to the boom and superstructure.
- ▶ Crowd the bucket in (down) while closing the clam. This practise makes use of gravity to help minimise shock loading on the bucket cylinders.
- ▶ Never dig, or attempt to bring down any material overhang, with the bucket while the clam is open or partly open.
- ▶ Do not attempt to dig or clean the floor or face with the clam open. These practises can cause considerable damage to the clam cylinders.

0° ≤ α ≤ 50°
25° ≤ β × ≤ 50°
(2x) LC= 16.7t
D210/d85
E50



β ≤ 30°
SWL=16t
D210/d85
E50



0° ≤ α ≤ 50°
25° ≤ β × ≤ 50°
LC= 16.7t
D210/d85
E50

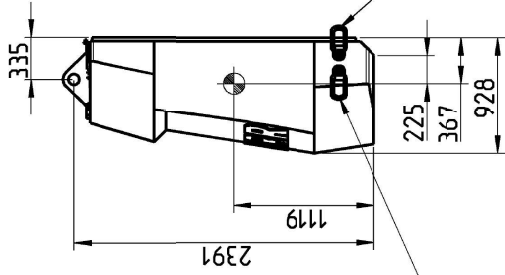

Beide Seiten
Both sides
Des deux cotés

0° ≤ α ≤ 15°
65° ≤ β × ≤ 90°
LC= 10t
D122/d82
E26.5



Beide Seiten
Both sides
Des deux cotés

0° ≤ α ≤ 15°
65° ≤ β × ≤ 90°
LC= 10t
D122/d82
E26.5

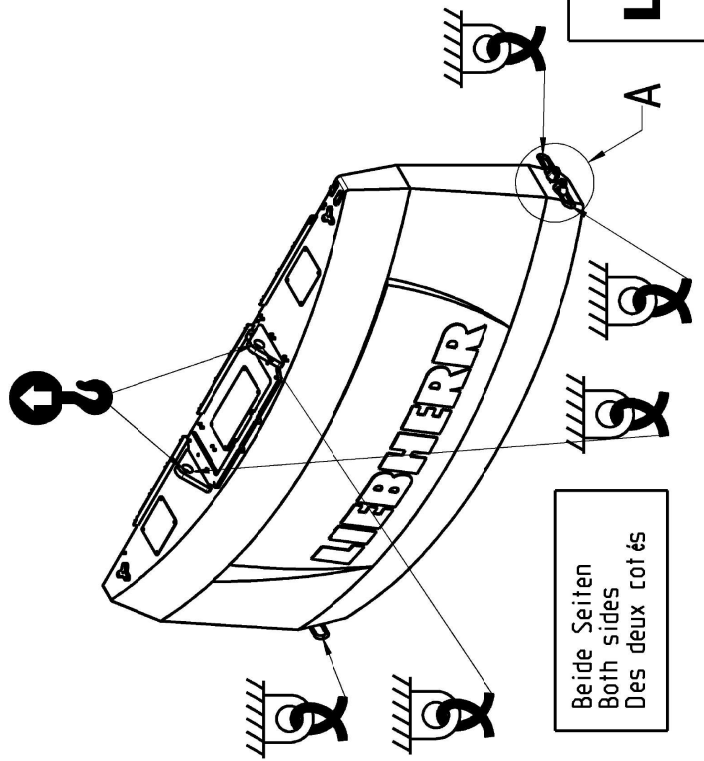
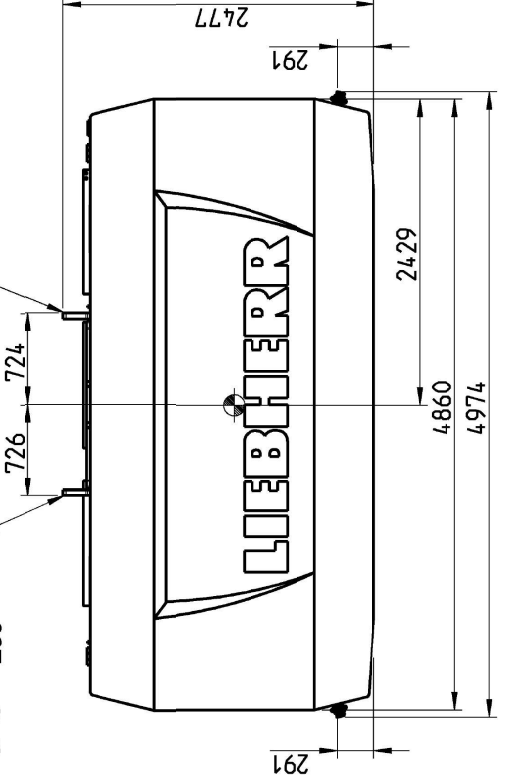

Beide Seiten
Both sides
Des deux cotés

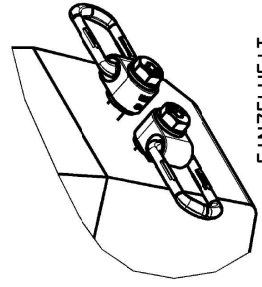

EINZELHEIT
DETAIL
DETAIL

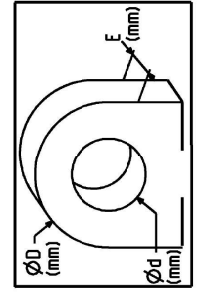

Gewicht ohne Werkzeug und Verpackung Weight without tool and packaging Poids sans outillage et emballage	22 000 kg
Gewicht mit Werkzeug und Verpackung Weight with tool and packaging Poids avec outillage et emballage	22 000 kg

SCHWERPUNKT
CENTER OF GRAVITY
CENTRE DE GRAVITE



Gerechnet Calculated Calculé	22 000 kg	Gewogen Weighed Pesé	

Bezeichnung / Description / Denomination	TRANSPORTPLAN BALLASTGEWICHT TRANSP.DRW.COUNTERWEIGHT R9200 PLAN DE TRANSP.CONTREPOIDS		
Ident.-Nr. / Ident. No.	13348187	Index / Index	100
Blatt / Page Feuille			1/1

LIEBHERR

4 Malfunctions

Warning messages and fault messages:

- Various faults are displayed on screen in the form of indicator lights or symbols (see chapter “Control and operating elements”).
- Warning functions can also be supported acoustically (buzzer).

Identifying and rectifying faults and errors:

- Faults can very often be traced back to incorrect operating or maintenance of the machine.

For each fault, therefore, read the relevant chapter in the operating instructions carefully once more.

- Analyse the cause of the fault and rectify it immediately.
- Describe the fault and all accompanying circumstances as precisely as possible if you contact LIEBHERR customer service.

Precise information makes it possible to find and rectify the cause of the fault quickly. Additionally, therefore, precise information on the type and serial number of the machine is also required.

- Do not carry out any work which you have not been trained to do.



Fig. 4-1 LIEBHERR service

If the cause of the fault cannot be recognised or rectified using the error codes and fault charts, please consult LIEBHERR customer service.

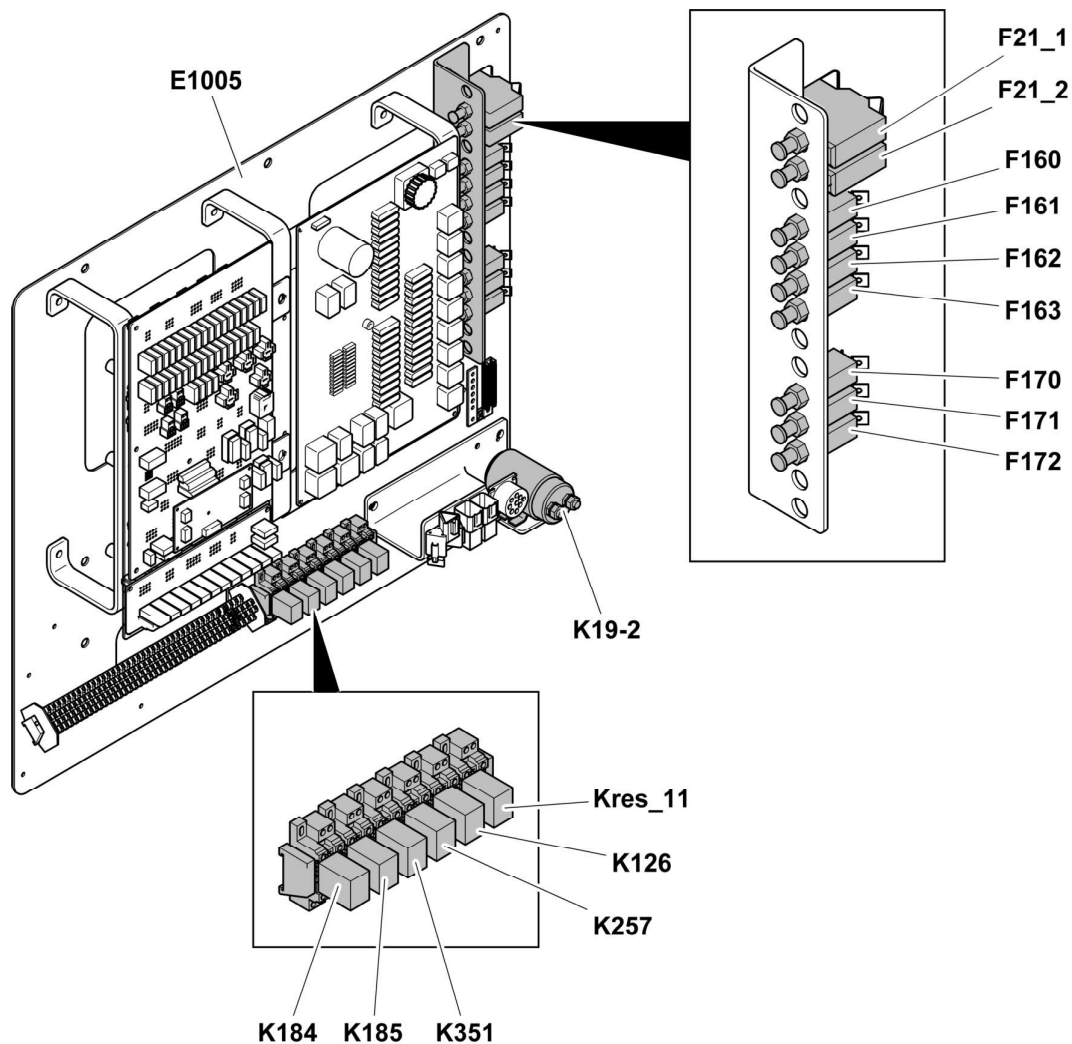

Fig. 4-7 Fuses and relays of cab connection box E1005

F21-1 Fuse 100 A	F172 Fuse 7,5 A
F21-2 Fuse 100 A	K19-2 Relay
F160 Fuse 7,5 A	K126 Relay
F161 Fuse 15 A	K184 Relay
F162 Fuse 15 A	K185 Relay
F163 Fuse 15 A	K257 Relay
F170 Fuse 15 A	K351 Relay
F171 Fuse 15 A	Kres_11 Relay

4.3.4 Electrical box E1091 for the Selective Catalytic Reduction (SCR) system

The electrical box E1091 for the Selective Catalytic Reduction (SCR) system is installed on the Diesel Exhaust Fluid (DEF) tank.

LEC/en/Edition: 03 / 2021

**Danger!**

Risk of falling when fall protection elements are removed.

The machine has anchor points for safe installation, maintenance and repair work.

Even if appropriate fall-arrest equipment is installed to the anchor points, fall-arrest equipment cannot prevent falls. Common sense and fall hazard awareness are important safety precautions for work that is done from above the ground.

5.3.1 Approved anchor points

There are four types of approved anchor points on the machine:

- welded anchor points
- drilled anchor points
- lifeline (optional)
- screwed anchor point (optional)



The welded and the drilled anchor points have a specific label (see § "Signs on the machine"). To be easily identified, the welded and the drilled anchor points are also painted in blue (in white if the excavator is blue).

The lifting points given in the section "Transport drawings" can also be used as anchor points.

The horizontal middle bar on handrails can also be used as anchor point (as illustrated below). The used handrail must have at least two vertical posts.

Couplings of the centralized lubrication system

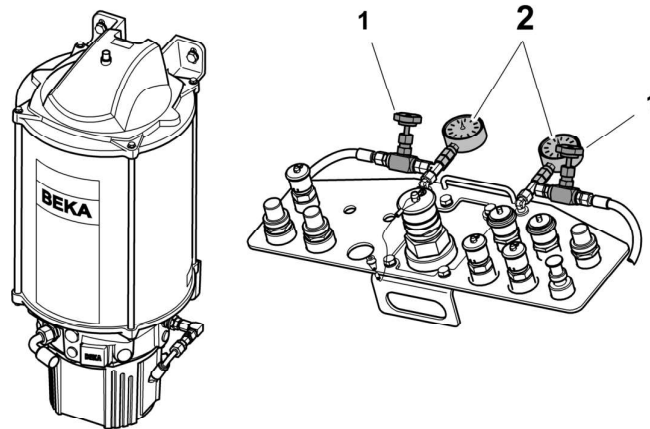

Fig. 5-7 Centralized lubrication system

- 1 Manual valves (2x)
- 2 Gauges (2x)

Symbol	Component	Wiggins adapter (with maximum flow)	Banlaw adapter (with maximum flow)
	Principal grease	6005A12 (15-30 l/min) Pmax 160 bar	GTXNBN (31 l/min) Pmax 160 bar
	Grease for swing ring teeth	6000B12 (15-30 l/min) Pmax 160 bar	GTXRB (31 l/min) Pmax 160 bar

You must also obey the procedure that follows to disconnect the couplings.

When the related pumps are stopped:

- ▶ Open the two manual valves 1.
- ▶ On the two gauges 2, check that the hydraulic pressure is zero.
- ▶ Disconnect the couplings.
- ▶ Close the two manual valves 2.

Couplings for the Diesel Exhaust Fluid (DEF)

Symbol	Component	Adapter (with maximum flow)
	Tank of the Diesel Exhaust Fluid (DEF)	Only to fill with DEF: Wiggins DEFN - 38-114 L/min
	Filling line of the Diesel Exhaust Fluid (DEF)	Only to drain the DEF: Wiggins DEFND - 38-114 L/min

Operate the service trap

The service trap is manually moved up and down from the ground level. As a help way, you can use the special lever 1, which is installed on the access ladder.

CLICK HERE TO **DOWNLOAD** THE COMPLETE MANUAL

- Thank you very much for reading the preview of the manual.
- You can download the complete manual from: www.heydownloads.com by clicking the link below



- Please note: If there is no response to CLICKING the link, please download this PDF first and then click on it.

CLICK HERE TO **DOWNLOAD** THE COMPLETE MANUAL

Engine oil	fans speed regulation setting
SAE30 (ISO VG100)	"STANDARD"
SAE 10W (ISO VG46)	"EXTRA-COLD" or "COLD"

Hydraulic oils for hydraulic system

Requirements

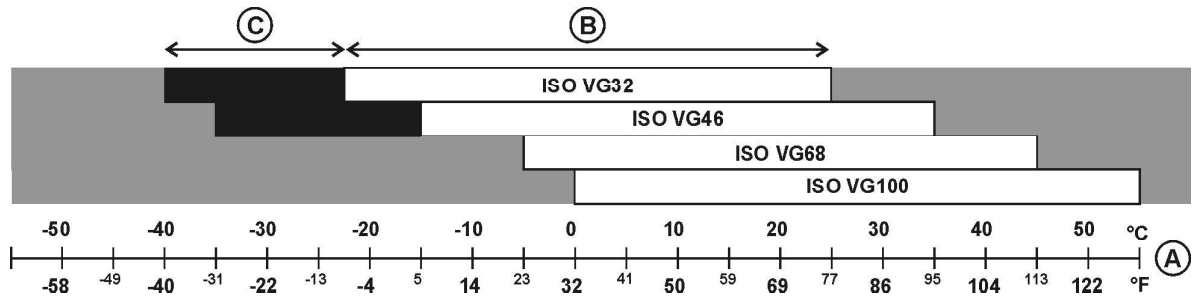

Fig. 5-18 Hydraulic oil for hydraulic system

- A Ambient air temperature
- B Operating range
- C Extra-cold start range if excavator fitted with operating Liebherr arctic kit (with warm-up instruction)



Caution!

Minimum ambient air temperature for extra-cold start depends on oil type and brand and equals to oil pourpoint temperature +5 degrees K.

Hydraulic oils must contain dispersant and detergent additives and conform to one of the following specifications:

DIN	ISO
51524-2 (HLP, HLP-D)	ISO 11158 (HM)
51524-3 (HVLP, HVLP-D)	ISO 11158 (HV)

Additional requirements:

Test/Requirement	Standard/Reference	Required level/Performance
Shear stability	DIN 51350-6 CEC L 45-A-99	KRL/C < 15%

LEC/en/Edition: 03 / 2021

- top-up oil quantity since last sample
- sampled oil type
- ▶ Send the sample in oil-proof adapted material.
- ▶ Check for the required sample delivery time and for sample export licence (if the laboratory is located out of the country, make sure that the export of the sample is authorized from your location to the laboratory).
- ▶ Do not wait before sending the sample to the laboratory.
- ▶ Record and save sampling operations and results.

If you get the oil sample with a sampling pump:

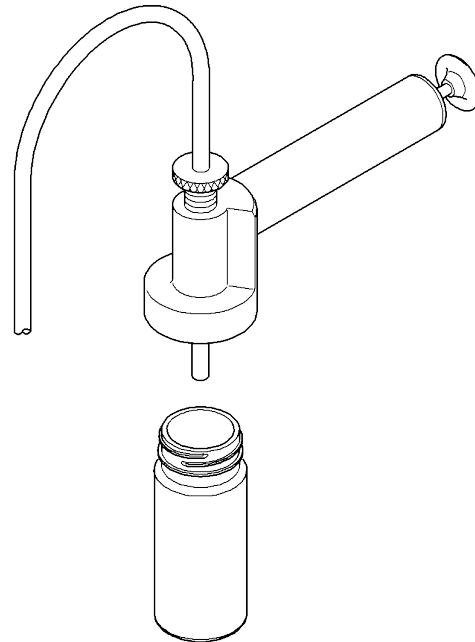

Fig. 5-23 Sampling pump

- ▶ Use a sampling pump if you get the sample directly in the tank or on the component (machine stopped).
- ▶ Always use a new sampling hose.
- ▶ Cut the sampling hose to the correct length (e.g. dipstick length plus 20 mm).
- ▶ First, let sufficient oil flow to flush the sampling hose.
- ▶ If you get the oil sample in the tank, take the sample in the middle of the tank.

If you get the oil sample through a sampling valve:

- ▶ Always use a new sampling hose.
- ▶ First, let sufficient oil flow to flush the sampling hose.
- ▶ Get the oil sample in the mid-stream, i.e. first let a small amount of oil flow through the valve before sampling it.

Sampling material

- ▶ You can order LIEBHERR approved sampling material to get the samples:

- ▶ Check the oil level with the dipstick 1.

5.7.2 Change the Diesel engine oil

- ▶ For oil quantities, oil specifications and oil change intervals, refer to the lubricant chart and to the control and maintenance chart.
- ▶ After each time you change or add oil, make sure that you get the correct oil level on the dipstick.

Drain the oil



Danger!

The Diesel engine oil is hot when it is at operating temperature!
Risk of burning.

- ▶ Avoid contact with hot oil and components containing oil as it can cause dangerous burns.

Drain the oil with the service trap

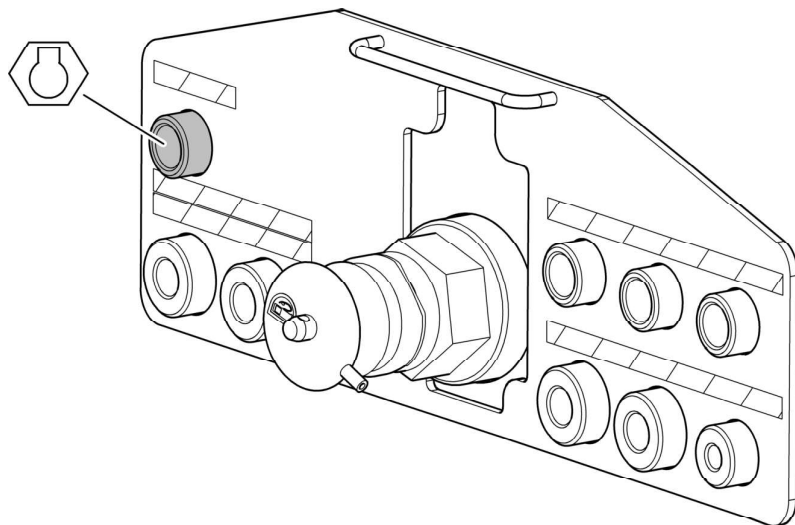

Fig. 5-29 Location of the quick coupling on the service trap

- ▶ Park the machine on level ground.
- ▶ Make sure that the Diesel engine oil is at operating temperature.
- ▶ Stop the Diesel engine.
- ▶ Use the quick coupling of the service trap.

Drain the oil through the drain plug of the Diesel engine

As a help way, you can also drain the oil through the drain plug of the Diesel engine, which is located on the oil pan.

5.9 Coupling

5.9.1 Check the coupling rubber rollers

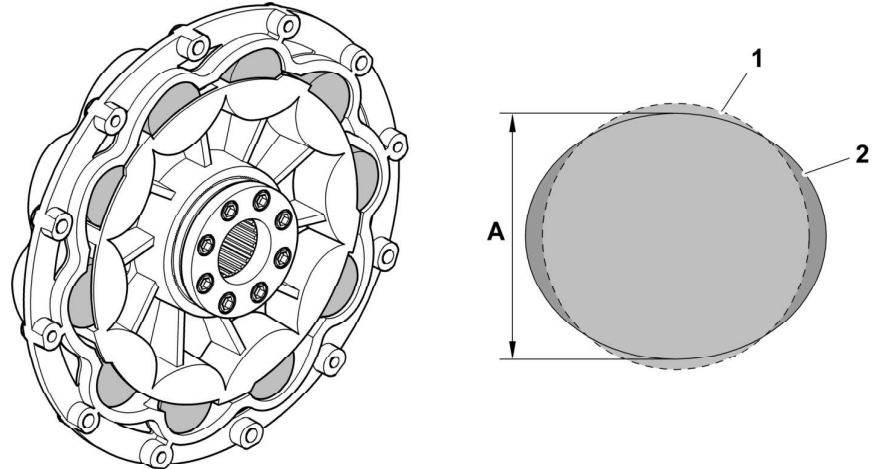

Fig. 5-39 Check the coupling rubber rollers

- 1 Rubber roller (new)
- 2 Rubber roller (with oval deformation because of normal wear)
- A Test distance

Make sure that the following preconditions are met:

- The machine is safely parked on firm and level ground.
- The Diesel engine is stopped.
- ▶ Examine the condition of the rubber rollers.

If a rubber roller is damaged:

- ▶ Replace all the rubber rollers immediately.
- ▶ Measure distance **A** of the rubber rollers.

If distance **A** is smaller than the minimum permitted distance of 75 mm:

- ▶ Replace all the rubber rollers immediately.

5.10 Cooling system

5.10.1 Check and clean the cooling system

To get optimal cooling, the cooler must be kept clean.

Location of the fuel shutoff valve

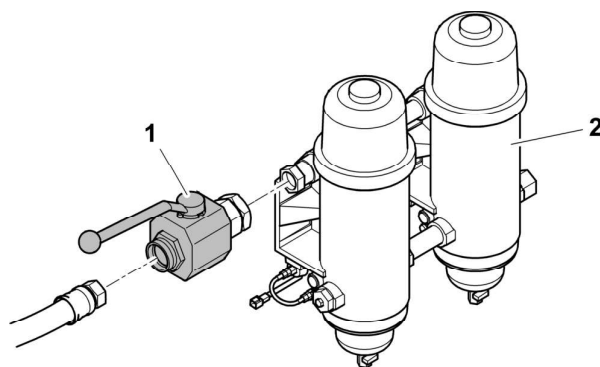

Fig. 5-49 Fuel shutoff valve

- 1 Fuel shutoff valve
- 2 Preliminary filters

The fuel shutoff valve 1 is installed upstream the preliminary filters 2.

On the preliminary filter

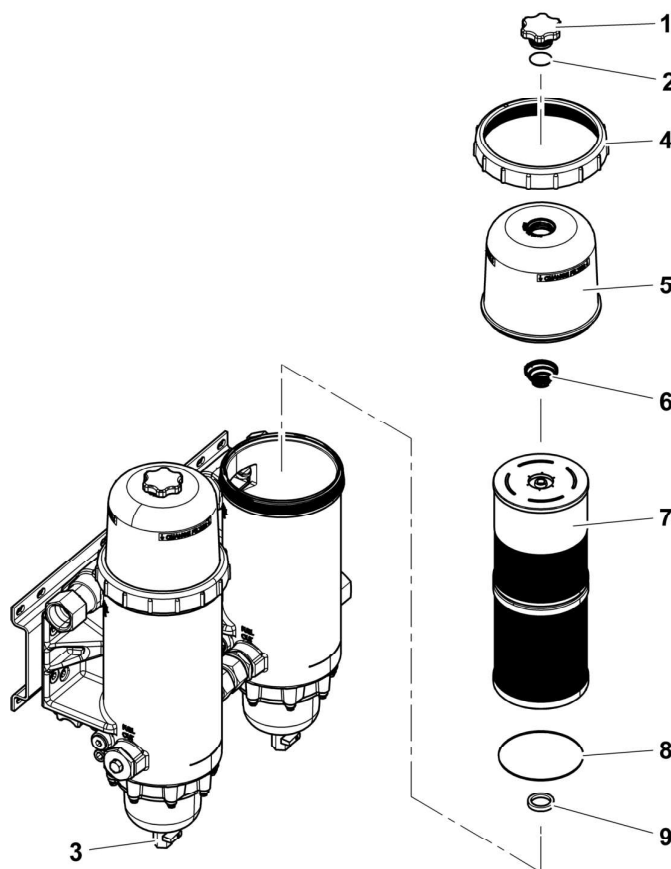

Fig. 5-50 Filter element on preliminary filter

- 1 Vent cap
- 6 Spring

LEC/en/Edition: 03 / 2021

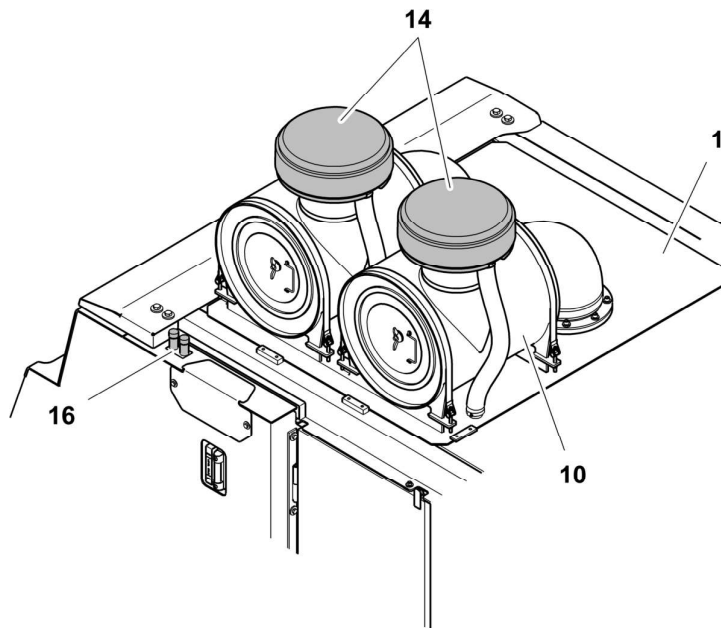

Fig. 5-59 Air intake system

- | | | | |
|-----------|-----------------------------|-----------|------------------|
| 1 | Engine compartment covering | 14 | Precleaner |
| 10 | Housing of dry air filter | 16 | Vacuum indicator |

The air cleaner, with precleaner **14**, primary and safety elements, is designed to give maximum protection at long maintenance intervals.

Maintenance also includes the replacement of the filter elements.

The vacuum indicator **16** stores the maximum recorded vacuum pressure on the filter outlet, during the Diesel engine operation.

Depending on the machines, the vacuum indicator can be different. Thus, you can have:

- a vacuum indicator - restriction gauge
- a vacuum indicator - switch

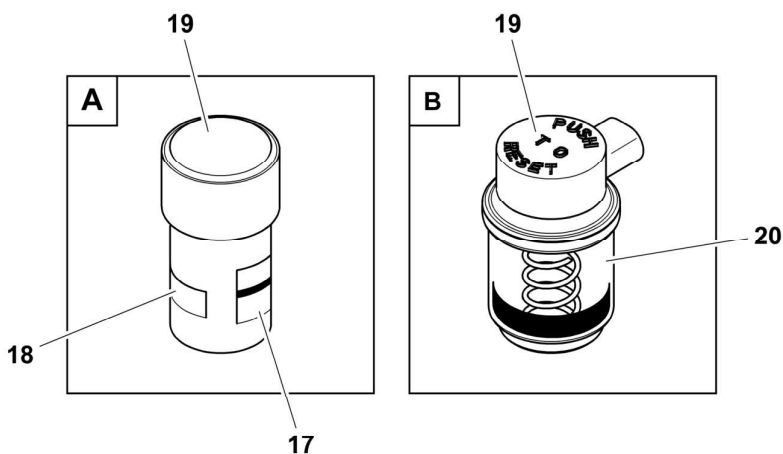

Fig. 5-60 Vacuum indicator

Fill the oil through the service trap

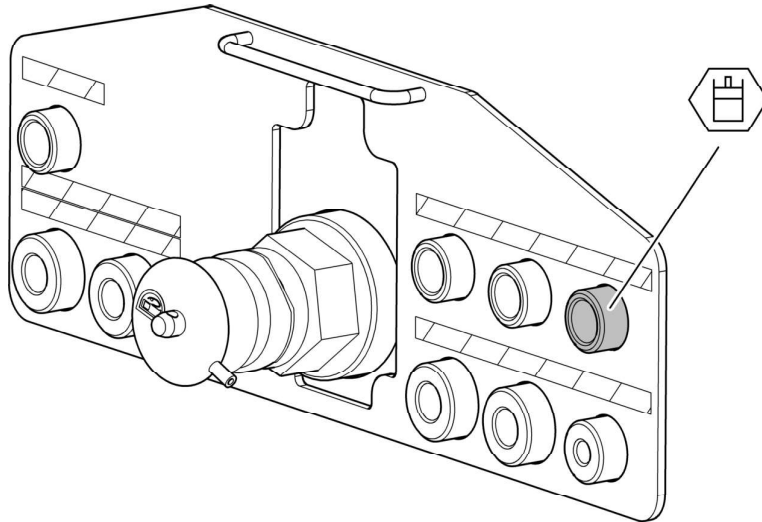

Fig. 5-69 Hydraulic oil change coupling on service trap

- ▶ Set the machine in the check position given before in this section.
- ▶ Release the hydraulic pressure as given before.
- ▶ Use the related quick change coupling of the service trap to refill hydraulic oil until you get the correct oil level.
- ▶ Close the breather filter.

5.14.10 Remove the pumps intake hoses

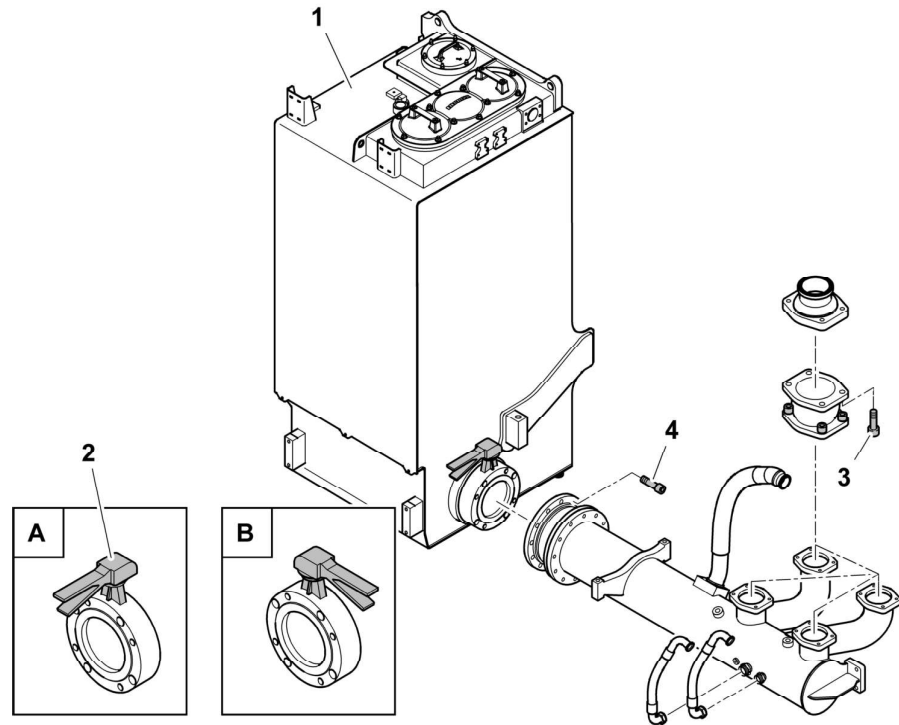

Fig. 5-79 Pumps intake hoses (aspiration)

- | | | | |
|---|-------------------------|---|--------|
| 1 | Hydraulic tank | 3 | Screws |
| 2 | Hydraulic shutoff valve | 4 | Screws |

Remove intake hoses and compensators

- ▶ Release the pressure from the hydraulic system as given before.
- ▶ Turn hydraulic shutoff **2** valve from position **A** to position **B** to close it.
- ▶ Drain the leak oil circuit.
For more information refer to section "Appendix" of this manual.
- ▶ Remove related intake hose and compensator.
- ▶ Drain the hydraulic oil in an applicable container.
- ▶ Install intake hoses and compensators:
 - Apply Loctite 243 on screws **3** and torque it to 35 +17 Nm.
 - Apply Loctite 243 on screws **4** and torque it to 180 +90 Nm.
- ▶ When the repair work is completed, turn hydraulic shutoff **2** valve from position **B** to position **A** to open it.
- ▶ Close the breather filter.

5.14.11 Bleed the hydraulic pumps

After working on the pumps or after oil change in the hydraulic system, you must bleed the hydraulic pumps.

face.

- ▶ Put the hose onto the bearing surface.
- ▶ Install the second half flange.
- ▶ Tighten mounting screws to the prescribed torque value and by following the progressive criss-cross tightening procedure described further in this chapter.

5.14.17 Progressive criss-cross tightening procedure



Note!

Always use this procedure to install the following flanges types:

- half flanges,
- single-part flanges,
- conical flanges,
- monobloc flanges (welded).

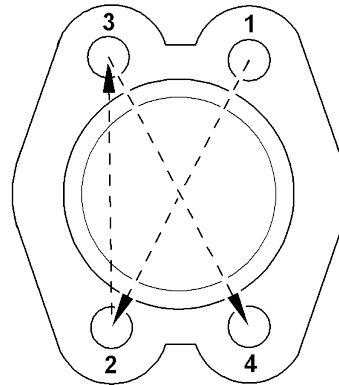

Fig. 5-90 Criss-cross tightening

- ▶ Make sure that all mounting surfaces have no damage, grease or contamination.
- ▶ Install the O-ring in the groove of the hose fitting.
You can use grease to hold the O-ring in position into the groove.
Be careful not to apply too much grease because it could look like a leak during operation.
- ▶ Put the hose in position onto the mounting surface (be careful that you do not cause damage to the O-ring or remove the O-ring).
- ▶ Pre-install the flange and pre-tighten the mounting screws by hand.
- ▶ Tighten the screws progressively in a criss-cross pattern:
 - first to 50% of the prescribed torque value,
 - then to 100% of the prescribed torque value,
 - do it again until the flange is tightened equally: the screw heads must not turn when you apply 100% of the prescribed torque value.

Track pad fastening

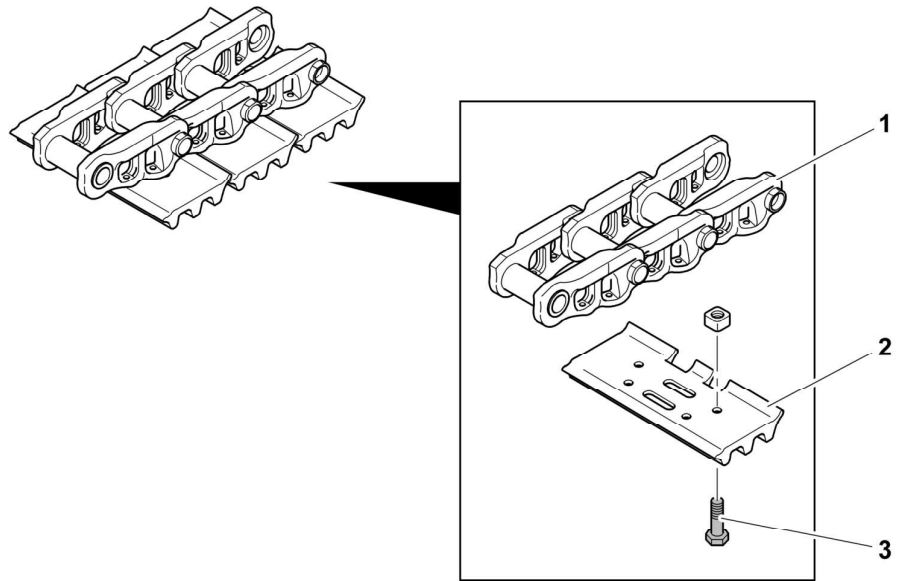

Fig. 5-98 Track pad fastening

- 1 Track link
- 2 Track pad
- 3 Screw M36x150-12.9 x quantity 4 for each track pad

Fastening

-

-

Do a check:

- 3780 Nm

Install a new screw:

- first 1000 ± 50 Nm

- then 160° + 10°

► When you install a track pad or a track link, the related screws and pins must be clean and greased with black grease (ID. 8503279).

Carrier roller fastening

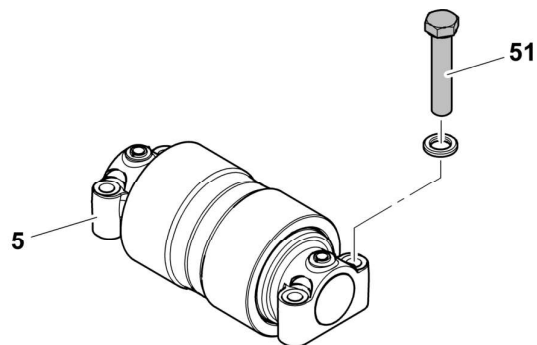

Fig. 5-99 Carrier roller fastening

- 5 Carrier roller

Torque

-

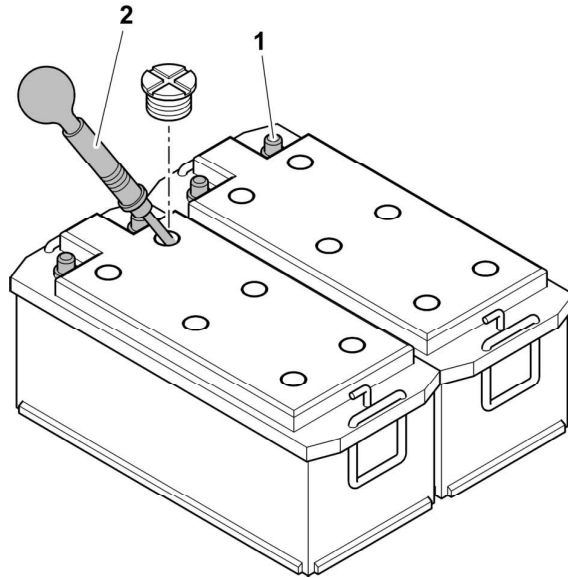

Fig. 5-109 Battery care

- 1 Cable terminals
- 2 Acid tester

► From time to time, measure the acid concentration using an acid tester 2.

When the battery is fully charged, the **unit weight is 1,28 kg/L (31,5° Bé)**.

► If the acid tester shows a lower value, the batteries is virtually flat and should be charged if necessary.

Check the dryer/receiver unit

Fig. 5-117 Location of the dryer/receiver unit

- 1 Dryer/receiver unit
- 2 Oil cooler box

The dryer/receiver unit 1 is installed on the oil cooler box 2.

► Obey the maintenance instructions given in the section "General procedures".

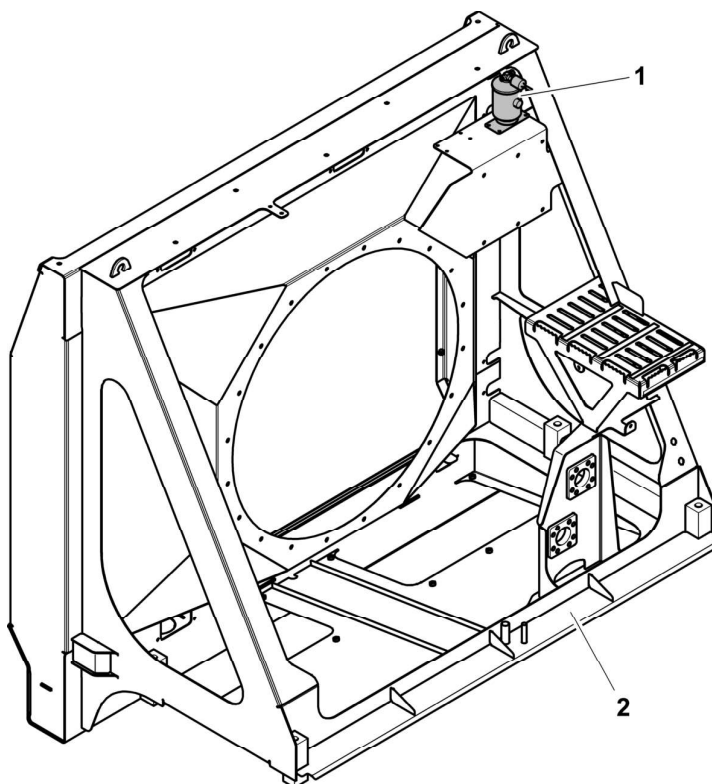
5.20.3 Mounting bolts of the fuel tank

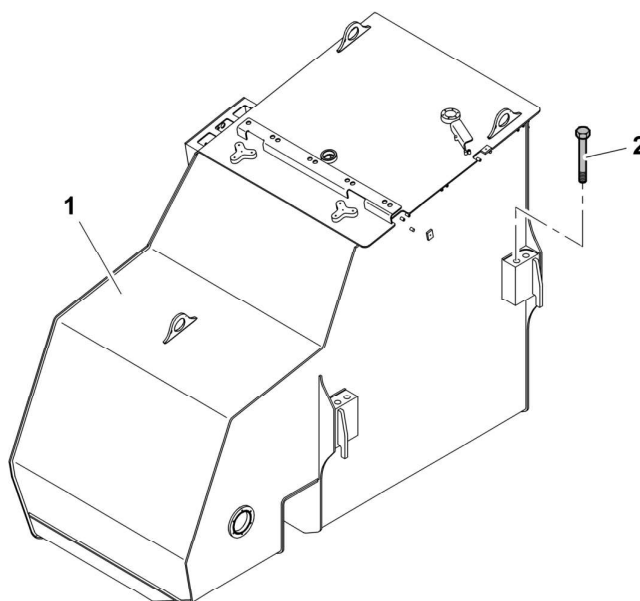

Fig. 5-126 Fuel tank bolts

		Torque	Quantity
1	Fuel tank	-	-
2	Screw M30x300	1920 Nm	6

**Note!**

If you find damage(s) on structural components (boom, stick, bucket, central part, side frames, rotating deck, hydraulic tank, fuel tank or cabin) please fill out the "Structural Inspection" form in Service Manual - Chapter 4.

In addition:

- a visual inspection is required every 500 hours,
- a detailed inspection is required every year or at least every 7500 hours.

5.23.1 General information

The following maintenance chart will help you to do the adequate maintenance on your excavator.

It is mandatory to follow these maintenance charts, to keep your excavator into best and safe condition.

The pre-requisite to any claim to Liebherr for operation issues or warranty, is that these maintenance charts are strictly followed and recorded.

It is mandatory to follow these requirements in order to keep your excavator safe, efficient and also for warranty reason. Liebherr is not responsible in case of damage if the maintenance requirements are not correctly followed. Moreover, your machine may not be running as efficiently and productively as it could be.

For lubricants and operating fluids, refer to the Operating Manual chapter 5.3.

Two types of inspection

Visual Check

- A visual examination of an interior or exterior area, installation or assembly to detect obvious damage, failure or irregularity. This level of inspection is made from within touching distance unless otherwise specified. A mirror may be necessary to ensure visual access to all surfaces in the inspection area. This level of inspection is made under normally available lighting conditions such as daylight, hangar lighting, flashlight or drop-light and may require removal or opening of access panels or doors. Stands, ladders or platforms may be required to have safe access to the area being checked.

Detailed Check

- An intensive examination of a specific item, installation or assembly to detect damage, failure or irregularity. This examination may require the use of specialized inspection techniques and/or equipment. Surface cleaning and elaborate access may also be required.

5.23.2 How to use the maintenance chart

The following maintenance chart is split in 5 individual check lists:

- a daily,
- a 250 hours,
- a 500 hours,
- a 1000 hours,
- and a 2000 hours.

WORK TO BE PERFORMED AT 250, 750, 1250 HOURS, ...	Check	Initials	Comments
Check <input type="checkbox"/> for first and only interval or Check <input type="radio"/> for repeat interval			
Do a visual check of the engine and external pipework for leaks	<input type="radio"/>		
Do a visual check of the exhaust gas system connections for leaks	<input type="radio"/>		
Do a visual check of the oil supply / return pipework for leaks	<input type="radio"/>		
Drain off water and sediment at fuel tank	<input type="radio"/>		
Do a visual check of the water separator on fuel filters, drain if necessary	<input type="radio"/>		
Do a visual check of the vacuum indicators for air filters clogging, replace if necessary and reset the indicator	<input type="radio"/>		
Do a visual check of the precleaner	<input type="radio"/>		
Replace primary element of the air filter (if necessary or at least once a year)	<input type="radio"/>		
Replace safety element of the air filter if indicated (if necessary or at least once a year)	<input type="radio"/>		
Do a visual check of the coupling for cracks, chips and missing parts	<input type="radio"/>		
Check oil level in the splitterbox	<input type="radio"/>		
Change oil in splitterbox	<input type="checkbox"/>		
Do a visual check of the splitterbox input shaft seal or engine main rear seal for leaks	<input type="radio"/>		
Do a visual check of the starter motors, alternator and AC compressor for cables, and brackets	<input type="radio"/>		
Do a visual check of the air intake hose for condition and leaks	<input type="radio"/>		
Do a visual check of the coolers for clogging and damage, clean or replace if necessary	<input type="radio"/>		
Do a visual check of the radiator core and fan, clean if necessary	<input type="radio"/>		
Do a visual check of the radiator cap for leaks, replace if necessary	<input type="radio"/>		
Perform the complete "Daily" Maintenance Echelon given in the CUMMINS Operating and Maintenance Manual	<input type="radio"/>		
Every 250hours or 6 months, perform a complete Maintenance Echelon given in the CUMMINS Operating and Maintenance Manual	<input type="radio"/>		
See CUMMINS Operation and Maintenance Manual for other maintenance (Eliminator, Centinel, Fleetguard, valves and injectors adjustment)	<input type="radio"/>		
HYDRAULIC SYSTEM			
Check oil level in hydraulic tank	<input type="radio"/>		
Sample and analyse hydraulic oil and change oil if necessary (if filled with HEES biodegradable oil)	<input type="radio"/>		
Clean magnetic rods of the leak oil filter	<input type="radio"/>		
Clean magnetic rods of all return filters	<input type="radio"/>		

LEC/en/Edition: 03 / 2021

<p>WORK TO BE PERFORMED AT 500, 1500, 2500 HOURS, ...</p> <p>Check <input type="checkbox"/> for first and only interval or Check <input type="radio"/> for repeat interval</p>	<p>Check</p>	<p>Initials</p>	<p>Comments</p>
<p>General comments:</p>			

LEC/en/Edition: 03 / 2021

Tab. 5-11 500 Hours maintenance schedule - R9200

WORK TO BE PERFORMED AT 2000, 4000, 6000 HOURS, ...	Check	Initials	Comments
Check <input type="checkbox"/> for first and only interval or Check <input type="radio"/> for repeat interval			
Uppercarriage: Do a detailed check for missing, broken or loosen mounting screws of the counterweight, tanks, Powerpack, control valve console, cab, cab elevation, catwalks, handrails, grease box, ladder, tighten the screws	<input type="radio"/>		
Swing gear: Do a visual check for missing, broken or loosen mounting bolts of the swing gear and hydraulic motors, tighten if necessary	<input type="radio"/>		
Swing gear: Do a detailed check for missing, broken or loosen mounting bolts of the swing gear and hydraulic motors, tighten the bolts	<input type="radio"/>		
Swing ring: Do a detailed check for missing, broken or loosen mounting screws and protective nuts of swing ring, tighten the bolts	<input type="radio"/>		
Diesel engine: Do a visual check for missing, broken or loosen mounting screws of the thermic protection on exhaust manifold fastening, tighten if necessary	<input type="radio"/>		
Diesel engine: Do a visual check for missing, broken or loosen mounting bolts of the starter motors, alternator and AC compressor, tighten if necessary	<input type="radio"/>		
Diesel engine: Do a detailed check for missing, broken or loosen mounting screws of the splitterbox, tighten the screws	<input type="radio"/>		
Diesel engine: Do a detailed check for missing, broken or loosen mounting screws of the engine, tighten the screws	<input type="radio"/>		
Hydraulic: Do a detailed check for missing, broken or loosen mounting screws of pumps, motors, clamps, ..., tighten the screws	<input type="radio"/>		
Cabin: Do a visual check for missing, broken or loosen mounting screws of the AC compressor, tighten if necessary	<input type="radio"/>		
TRACK COMPONENTS			
Clean track chains (after the end of each shift)	<input type="radio"/>		
Do a visual check of the tensioning cylinders, idler, carrier and track rollers for leaks	<input type="radio"/>		
Do a visual check of the track chains tension	<input type="radio"/>		
Liebherr recommends to measure the track chains with TCM software	<input type="radio"/>		
TRAVEL GEAR			
Do a visual check of the gear for leaks, if there are leaks, check oil level	<input type="radio"/>		
Sample and analyse gear oil, change oil if necessary	<input type="radio"/>		
Change gear oil (if filled with COB-1 gear oil)	<input type="radio"/>		
Change gear oil (if filled with COB-2, COB-3 or COB-4 gear oil)	<input type="radio"/>		
Sample and analyse lifetime sealing interspace oil, change oil if necessary (optional equipment)	<input type="radio"/>		
Change lifetime sealing interspace oil (optional equipment)	<input type="radio"/>		
Change the oil of the external travel brake	<input type="radio"/>		

LEC/en/Edition: 03 / 2021

6 Appendix

6.1 Visual check of the hydraulic hoses

6.1.1 Preface

This section describes the **procedure for the visual check of the hydraulic hoses**.



Note!

These instructions have been written for the **maintenance personnel** of the machine.

The activities described in this section may only be carried out by specially trained personnel.

The instructions are to be read and used carefully by all persons who carry out work with or on the machine before putting the machine into service for the first time and later, at regular intervals.

The instructions must be completed by information on current national regulations for accident prevention and protection. In addition, authorized specialist rules for safe and correct working procedures are also to be observed.

However, should you require any further explanations or information, LIEBHERR technical documentation, sales school and customer service departments are available for your convenience.



Danger!

Fluid injection injuries have to be treated immediately!

- Fluid under pressure can cause serious injury. It can be almost invisible when it escapes from a pinhole and it can go through the skin and contaminate the blood.
 - Do not touch a pressurized hydraulic hose assembly with any part of your body.
 - If a fluid-injection accident occurs, medical treatment is necessary immediately.
 - Stay out of hazardous areas while testing hose assemblies under pressure. Use available safety protection.
 - Refer to "Isolate machine for hydraulic repair" safe work procedure in the Service Manual.
-

6.2.3 General cleaning procedure

- ▶ For the complete description about the works to do, also refer to the chapter 2 "Safe Works Procedures" of the Service Manual.
- ▶ Always obey the sequence that follows:
 - **Step 1:** Stop the engine. The attachment must stay on the ground.
 - **Step 2:** Make sure that there is no pressure in the system. Refer to the Operating manual.
 - **Step 3:** Drain the hydraulic tank. Refer to the Operating Manual.
 - **Step 4:** Disconnect, drain and clean with applicable tools all of the related hydraulic circuits. Refer to the sections below that give all the components of each hydraulic circuit.

Depending on the different assemblies, it is possible that you must disassemble some components.

- **Step 5:** Clean the hydraulic tank. Refer to the section "Hydraulic tank" below.
- **Step 6:** Install all of the hydraulic circuits again. Refer to the Operating manual for general installation procedures.
- **Step 7:** Do the restart procedure before you put the machine in operation. Refer to the section "Restart the machine" below.

6.2.4 Location of the hydraulic tank filters

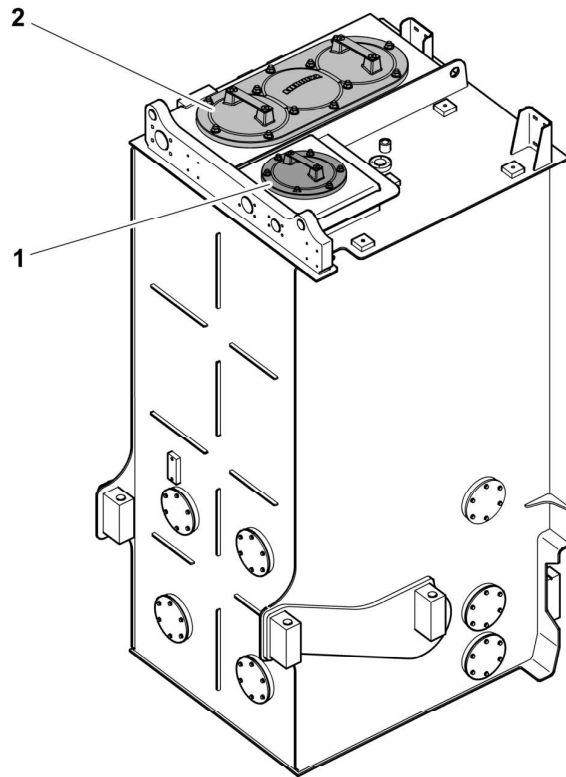

Fig. 6-6 Filters on the hydraulic tank

- 1 Leak oil filter

Leak oil circuit

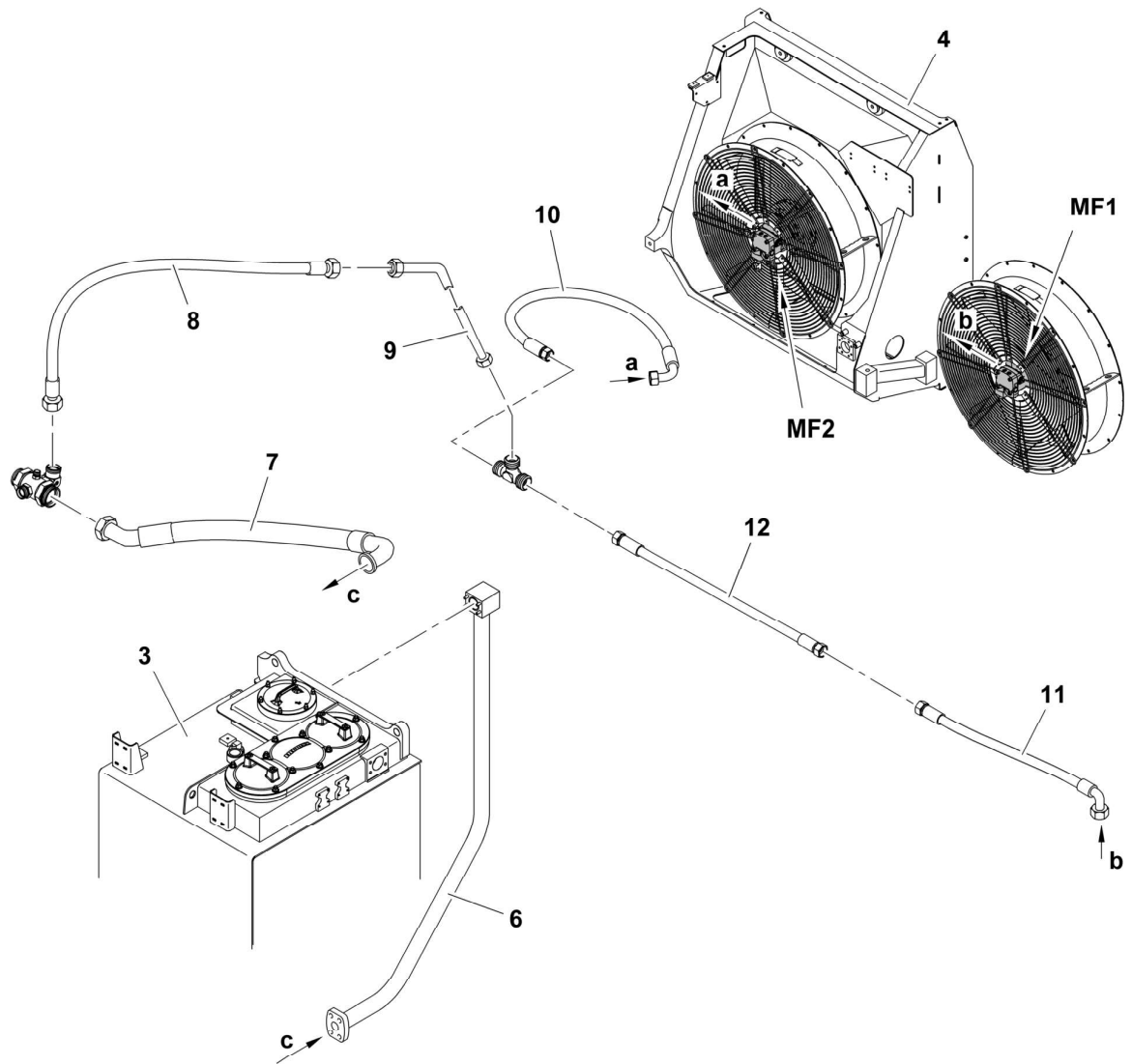

Fig. 6-16 Leak oil lines of fan motors

- | | | | |
|----------|----------------|------------|-----------------|
| 3 | Hydraulic tank | 10 | Hydraulic hose |
| 4 | Oil cooler box | 11 | Hydraulic hose |
| 6 | Hydraulic pipe | 12 | Hydraulic hose |
| 7 | Hydraulic hose | MF1 | Water fan motor |
| 8 | Hydraulic hose | MF2 | Oil fan motor |
| 9 | Hydraulic pipe | | |

LEC/en/Edition: 03 / 2021

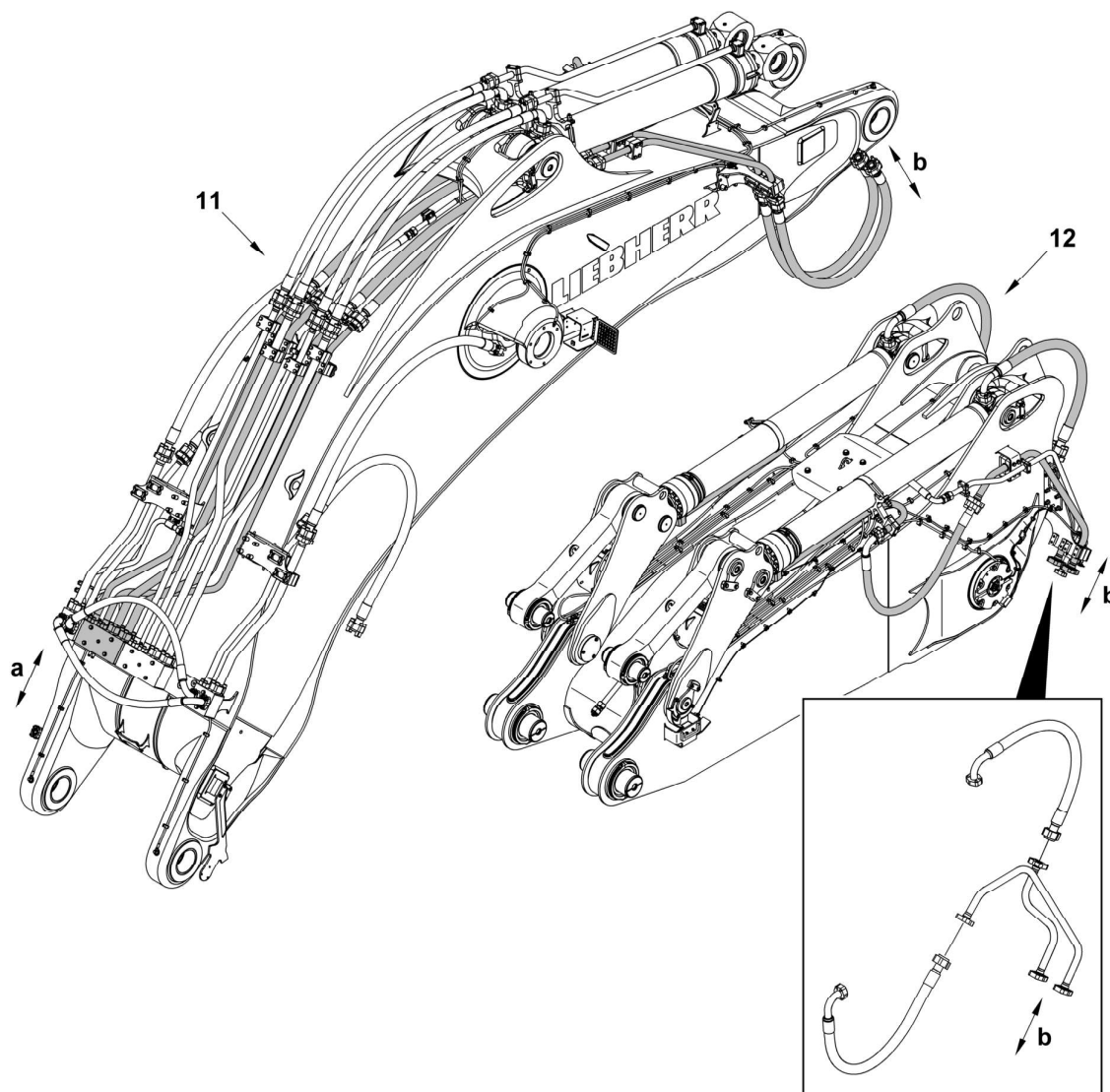

Fig. 6-26 Hydraulic lines on the attachment

- 11** Hydraulic lines installed on the boom
- 12** Hydraulic lines installed on the stick and on the bucket cylinders

- ▶ Disconnect, drain and clean all the hydraulic hoses, pipes and distribution blocks.
- ▶ Do the restart procedure before you put the machine in operation (refer to the related section).

LEC/en/Edition: 03 / 2021

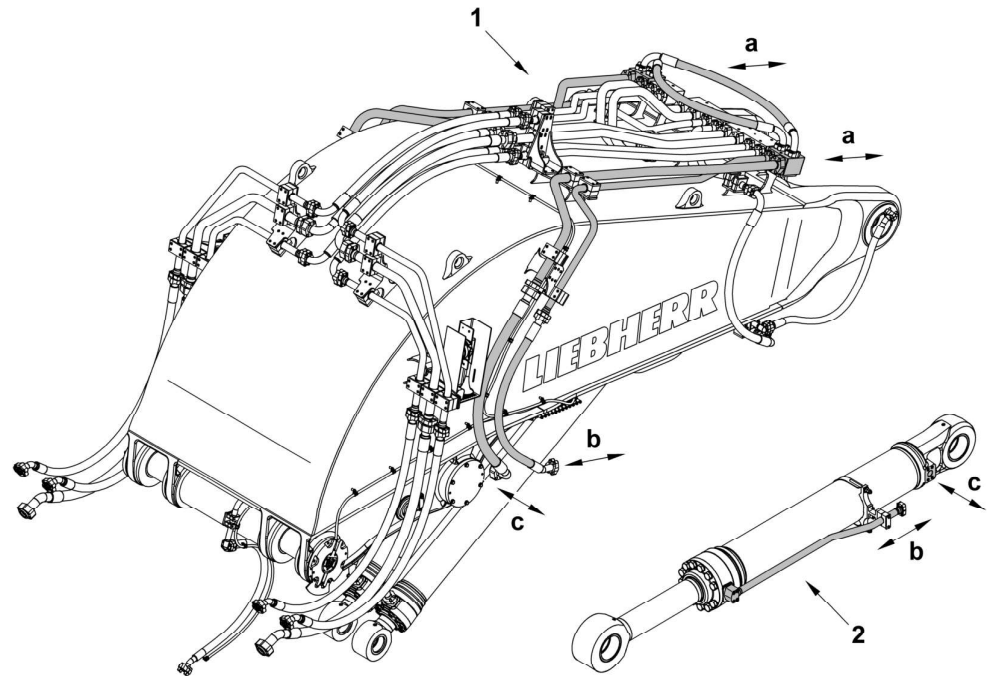

Fig. 6-36 Hydraulic lines on the boom

- 1 Hydraulic lines installed on the boom
- 2 Hydraulic pipe installed on the boom cylinders

- ▶ Disconnect, drain and clean all the hydraulic hoses, pipes and distribution blocks.
- ▶ Do the restart procedure before you put the machine in operation (refer to the related section).

- **Check :**

Upon entering the Check menu, the statuses of the analogue sensors are shown.

B 6 9	O K				
B 7 1	O K				
B 1 8 4	O K				
B 5 0 - 1	O K				
B 5 0 - 2	E R R				
					←

To represent Sensor values in mA, press and hold both "Up" and "Down" arrow buttons for more than three seconds. This will only apply when a service or inspector dongle is plugged.

B 6 9	1 2 mA	B 7 1	3 4 mA		
B 1 8 4	1 6 mA	B 5 1	1 2 mA		
B 5 0 _ 1	2 1 mA				
B 5 0 _ 2	1 9 mA				
B 1 5 0 - 1	9 mA				
B 1 5 0 - 2	9 mA				←

6. Appendix

- **Error List :**

G1: Press P1 stay low
G2: Press P2 stay low
G3: No feedback P3 line
G4: No press drop P1
G5: No press drop P2
G14: Lev sensor P1 NC
G17: Lev sensor P3 NC
G28: Grease lev P1 few
G29: Grease lev P3 few
G33: Grease lev P1 low
G34: Grease lev P3 low
G36: Pilot press low
G37: No feedback B150 - 1
G38: No feedback B150 - 2

9. Start up

Prior to putting the device into operation, it has to be checked that all safety devices are completely available and functional. All connections have to be correctly linked and professionally assembled.

9.1 Filling with lubricant

Caution!

The lubricant filling only takes place via the maintenance flap of the LIEBHERR mining excavator R 9200. The separate operating instruction of LIEBHERR has to be observed for this! As soon as the service station displays that the pump reservoirs are full, the filling operation has to be ended immediately. Otherwise, grease will leak out from the grease drums.

9.2 Filling of the container through service-plate

- Remove dust protective cap at the filling coupling and the dust protective cap at the filling nipple.
- Couple the filling hose for P1 resp. P3 and switch on the filling pump.
- When the reservoir is full, the sensor transmits an electric signal to the control unit. Visual control is possible by using the dipstick (P1) or the reservoir (P3). The solenoid valve for overfill protection will be closed.
- When the filling pump is switched off, disconnect the filling coupling and reinstall the dust protective caps.
- Lines are pressurized. Be careful when decoupling!
- Collect leaking lubricant in a suitable reservoir and dispose it professionally!
- Contaminated lubricant causes malfunctions and premature wear of the grease pump and other components of the system.
- Clean surroundings before exchanging or topping up.
- Switch off centralized lubrication system.
- Observe the machine manufacturer's lubricant details! Only use lubricants according to machine manufacturer's specifications!
- Observe the safety data sheet of the lubricant manufacturer!

Observe the operating manual and specifications of the mining excavator LIEBHERR R 9200.

Caution!

The entire central lubrication system has to be emptied, in case that a lubricant, which does not correspond to the LIEBHERR specifications, has been filled in by accident. Afterwards a lubricant according to the specifications has to be filled in and the entire system has to be ventilated.

9.3 Ventilation of the lubrication system

Ventilation can be achieved with a first filling of all hoses/pipes/lines prior to installation

9.4 Control of direction of rotation of the GIGA PLUS pump

- Compare the direction of rotation of the agitator blade with the directional arrow on the adhesive label of the reservoir!
- If the direction of rotation is wrong, check the connection to the terminal box and change it, as necessary!

Caution!

Longer operation with the **wrong direction of rotation** will cause **motor and pump damage!**

10.3 Description system P3

The central lubrication pump GIGA PLUS supplies lubricant to each lubrication point via the connected progressive distributors SX-5.

10.3.1 Configuration progressive system

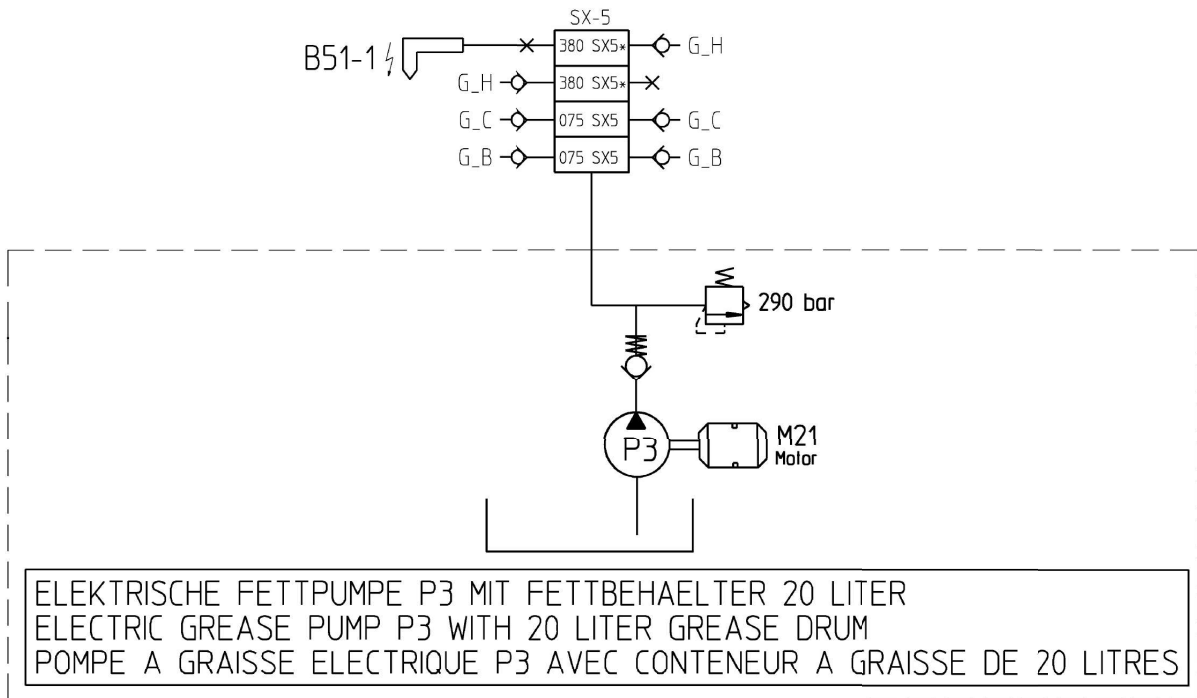

Fig. 14: Scheme toothed ring lubrication

CLICK HERE TO **DOWNLOAD** THE COMPLETE MANUAL

- Thank you very much for reading the preview of the manual.
- You can download the complete manual from: www.heydownloads.com by clicking the link below



- Please note: If there is no response to CLICKING the link, please download this PDF first and then click on it.

CLICK HERE TO **DOWNLOAD** THE COMPLETE MANUAL