

en

Operating manual

Wheel loader

L 566-460

From serial number 24314

Document ID

	ORIGINAL OPERATING MANUAL
Order number:	11002115
Issued:	06-2013
Version:	09
Author:	LBH / Technical Documentation Department

Product ID

Manufacturer:	Liebherr-Werk Bischofshofen GmbH
Type:	L 566
Type no.:	460
Serial no. from:	24314

Conformity:



Contact

Address:	Liebherr-Werk Bischofshofen GmbH Dr. Hans Liebherr-Straße 4 A – 5500 Bischofshofen
-----------------	--

CLICK HERE TO **DOWNLOAD** THE COMPLETE MANUAL

- Thank you very much for reading the preview of the manual.
- You can download the complete manual from: www.heydownloads.com by clicking the link below



- Please note: If there is no response to CLICKING the link, please download this PDF first and then click on it.

CLICK HERE TO **DOWNLOAD** THE COMPLETE MANUAL

Contents

1	Product description	19
1.1	Technical description	19
1.1.1	Overview of the complete machine	19
1.2	Technical data	21
1.2.1	Information on vibrations	21
1.2.2	Sound emission	22
1.2.3	Engine	22
1.2.4	Electrical system	22
1.2.5	Travel drive	23
1.2.6	Axles	23
1.2.7	Braking	24
1.2.8	Steering	24
1.2.9	Working hydraulics	25
1.2.10	Working attachment	25
1.2.11	Driver's cab	25
1.2.12	Heating, air conditioning	26
1.2.13	Air conditioning	26
1.2.14	Diesel particle filter	26
1.2.15	Refuelling pump	26
1.2.16	Towing device	27
1.2.17	Ballast	27
1.2.18	Tyres	28
1.2.19	Snow chains or guard chains	31
1.2.20	Tyres with foam	31
1.2.21	Complete machine with bucket (Z kinematics)	31
1.2.22	Attachment - high lift (Z kinematics)	33
1.2.23	Attachment - light material bucket	34
1.2.24	Attachment - high dump bucket	36
1.2.25	Attachment - forklift	37

1.2 Technical data

1.2.1 Information on vibrations

Hand, arm and whole-body vibrations

The driver's seat installed in the machine by the manufacturer complies with ISO 7096:2000, EM3 for wheel loaders. If the seat is replaced, the new seat must also comply with this standard.

Hand/arm vibrations

When the machine is correctly operated, the weighted (frequency-evaluated) effective value for hand/arm vibrations as per ISO 5349-1:2001 is less than 2.5 m/s².

Whole-body vibrations

When the machine is correctly operated, weighted (frequency-evaluated) effective values for certain example applications of the machine can be seen in the tables listed below. These values are based on the information in the technical report ISO/TR 25398:2006 "Earth-moving machinery - Guidelines for assessment of exposure to whole-body vibration of ride-on machines - Use of harmonized data measured by international institutes, organizations and manufacturers". The measuring method corresponds to ISO 2631-1:1997. The listed effective values for typical machines are given with standard deviations. These deviations are classified according to light, normal and heavy-duty operating conditions. The operator must classify the operating conditions according to the terrain, site conditions, site organisation, material, machine equipment, mode of operation and expertise of the driver.

Because the stated values are individual effective values for certain common applications, it is only possible to approximately assess the driver's exposure to vibrations. Therefore, in order to precisely assess the driver's exposure to vibrations during an 8-hour working day, use the Liebherr brochure on whole-body vibrations and the special software. Both of these are available from Liebherr dealers or with the documentation CD (Liebherr Parts) supplied with each new machine.

(For more information see: [2.4.19 Protection against vibrations, page 65](#))

Machine type	Typical working cycles	Weighted effective value in m/s ² under light, normal and heavy-duty operating conditions								
		x axis			y axis			z axis		
		Light	Normal	Heavy	Light	Normal	Heavy	Light	Normal	Heavy
Wheel loader	Load & Carry	0.44	0.60	0.76	0.44	0.58	0.72	0.38	0.52	0.66
	Transfer	0.31	0.54	0.78	0.40	0.65	0.90	0.32	0.49	0.66
	V mode	0.50	0.71	0.91	0.37	0.60	0.83	0.40	0.54	0.68
	Mining	0.57	0.91	1.24	0.47	0.69	0.91	0.34	0.81	1.28

Tab. 1: The measuring uncertainty is defined in the EN 12096:1997 standard.

1.2.19 Snow chains or guard chains



bpik0044

This equipment is optional.

When snow chains or guard chains are used, they must be attached to all four wheels.



Note

Failure to do this can damage the drive system.

► [\(For more information see: 2.4.18 Attachments and accessories, page 65\)](#) .

If chains are attached to the tyres, the ballast needs to be modified.

[\(For more information see: 1.2.17 Ballast, page 27\)](#)



Note

Installing or changing the working attachment or tyres.

► [\(For more information see: 2.4.18 Attachments and accessories, page 65\)](#)

1.2.20 Tyres with foam

This equipment is optional.

When tyres with foam are used, they must be attached to all four wheels.

If the tyres are filled with foam, the ballast needs to be modified. [\(For more information see: 1.2.17 Ballast, page 27\)](#)



Note

Installing or changing the working attachment or tyres.

► [\(For more information see: 2.4.18 Attachments and accessories, page 65\)](#)

1.2.21 Complete machine with bucket (Z kinematics)



bpik0039

The values stated refer to the machine:

- In its standard version
- With Michelin 26.5R25 XHA2 tyres,
- including all lubricants
- With a full tank
- With ROPS/FOPS cab and driver

Tyre sizes and additional attachments affect the operating weight and tipping load.

2 Safety warnings, signs

Working on the machine poses safety risks to the operator, driver or maintenance personnel. You can prevent risks and accidents by regularly reading and observing the various safety instructions.

This is especially important for personnel who only occasionally work on the machine, for example, carrying out rigging or maintenance work.

The safety instructions listed below, if conscientiously followed, will ensure your own safety and that of others, and will prevent the machine from being damaged.



Whenever tasks which could cause danger to personnel or damage to the machine are described, the necessary safety precautions are explained in this manual.

2.1 How the warnings are marked

	This is the warning symbol. It warns you of potential injuries. To prevent injury or death, carry out all the measures identified by this warning symbol.
--	---

Tab. 13

The warning symbol always appears together with the signal words:
DANGER, WARNING, CAUTION

	DANGER	indicates a hazardous situation that will immediately lead to serious or fatal injury if it is not avoided.
	WARNING	indicates a hazardous situation that may lead to serious or fatal injury if it is not avoided.
	CAUTION	indicates a hazardous situation that may lead to minor or moderate injury if it is not avoided.
	ATTENTION	indicates a hazardous situation that may lead to damage if it is not avoided.

Tab. 14

2.1.1 Further markings

	Note	indicates useful tips and information.
---	-------------	--

Tab. 15

Fire extinguisher sign

This equipment is optional.



Fig. 54: Fire extinguisher sign

Indicates that there is a fire extinguisher in the cab.

Working hydraulics sign

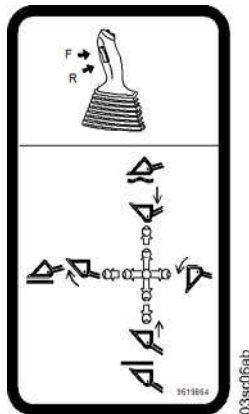

Fig. 55: Working hydraulics sign

It indicates the actuating directions of the control lever.

Bearing load table sign

This equipment is optional.

	LXXX	LXXX	LXXX	LXXX	LXXX	LXXX
	xxxxkg	xxxxkg	xxxxkg	xxxxkg	xxxxkg	xxxxkg
	xxxxkg	xxxxkg	xxxxkg	xxxxkg	xxxxkg	xxxxkg
ENxxxxx ISO xxxxxx					ID.:XXXXXXX	

Fig. 56: Bearing load table sign

Indicates the maximum permissible load in forklift operation.

The maximum permissible loads indicated on the sign refer to a machine equipped with standard tyres.

LBH/11002115/09/06-2013/en

13. Before starting maintenance or repairs, clean any oil, fuel or service fluids from the machine, especially connections and bolted joints. Do not use abrasive cleaning agents. Use fibre-free cloths.
14. Before welding, burning and sanding, clean any dust from the machine and the area around it, and ensure adequate ventilation.
Otherwise there is a risk of “**Explosion**” !
15. Before cleaning the machine with water, steam jet (high-pressure cleaner) or other cleaning agents, cover or tape up all openings where water, steam and cleaning agent may not penetrate for safety reasons.
Electric motors, control cabinets and battery compartments are at particular risk.

Further procedure:

- Make sure that during cleaning work on the machine housings, the temperature sensors for the fire alarm and extinguisher systems do not come into contact with hot cleaning agent. Otherwise the fire extinguishing system could be activated.
 - After cleaning, completely remove the covers and tape.
 - After cleaning, check all fuel, engine oil and hydraulic oil lines for leaks, loose connections, abrasion and damage.
 - Repair any defects immediately.
16. Follow the safety instructions for the product in question when handling oil, grease and other chemical substances.
 17. Dispose of spare parts and consumables in a safe, environmentally sound manner.
 18. Take care when handling hot operating and auxiliary materials (danger of burns and scalding).
 19. Only operate combustion engines and fuel-powered heaters in sufficiently ventilated rooms. Before starting the engine inside a building, make sure the room is well ventilated. Follow the local regulations in force at the site.
 20. Only carry out welding, burning and grinding work when it is expressly allowed, as otherwise you may cause fires or explosions.
 21. Do not try to lift heavy parts. Only use suitable equipment with sufficient load capacity.

Procedure:

- When replacing individual parts and larger assemblies, carefully fasten and secure them to the lifting gear so that no danger can arise.
- Only use suitable lifting gear in perfect order, and slinging equipment with sufficient load capacity.

Keep out from under suspended loads.

22. Do not use ropes which are damaged or of insufficient load bearing capacity. Wear protective gloves when handling wire ropes.
23. Only allow experienced personnel to sling loads and direct crane drivers. The person giving directions must remain in sight of the operator or at least be in spoken contact with him.
24. When carrying out fitting work above head height, use the safety climbing aids and working platforms provided or equivalent. Do not use parts of the machine for climbing. Wear a safety harness when working at height. Keep all handles, steps, rails, gangways, platforms and ladders free from dirt, snow and ice.
25. When working on the attachment (for example replacing teeth), make sure it is properly supported. Avoid direct metal-to-metal contact.
26. Never lie under the machine when it is raised using the working attachment, unless the undercarriage is securely supported using wooden beams.
27. Always support the machine on blocks, so that it cannot become unbalanced by any shift in weight. Avoid metal-to-metal contact.
28. Only trained specialist staff may perform work on the chassis, brake and steering systems.

- The vibration acceleration values (a_{zw}) are measured in accordance with ISO 2631, Part 1, and thus meet the standards for protection against overall body vibrations in EN 474-1.

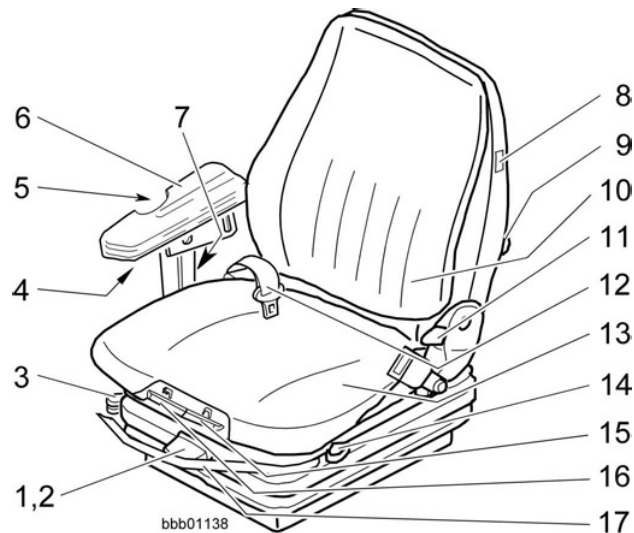

Fig. 84: Main components and adjustable elements of the driver's seat

- | | | | |
|---|---|----|---|
| 1 | Lever for adjusting body weight | 10 | Back rest |
| 2 | Lever for adjusting seat height | 11 | Lever for back rest inclination adjustment |
| 3 | Lever for adjusting suspension | 12 | Seat belt |
| 4 | Locking screw for arm rest horizontal adjustment | 13 | Seat surface |
| 5 | Locking screw for arm rest inclination adjustment | 14 | Lever for horizontal seat suspension |
| 6 | Arm rest | 15 | Lever for seat surface inclination adjustment |
| 7 | Locking screw for arm rest height adjustment | 16 | Lever for seat surface horizontal adjustment |
| 8 | Seat heating switch (optional) | 17 | Lever for driver's seat horizontal adjustment |
| 9 | Lumbar support knob | | |

Adjusting the driver's seat

The seat can be adjusted to the driver's individual requirements to provide the highest possible degree of comfort.



WARNING

There is a risk of injury if the driver's seat is not properly adjusted.

- ▶ Never adjust the driver's seat when the vehicle is moving.

Adjusting the body weight

The seat suspension can be adjusted to the driver's individual body weight.

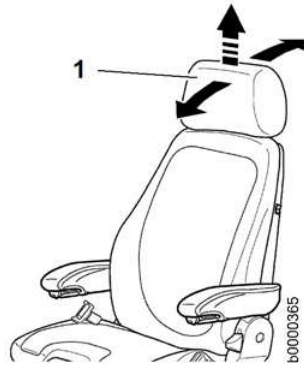

Fig. 102: Adjusting the head rest

1 Head rest

- ▶ Adjust the inclination and height of the head rest **1** by pulling or pushing it.
- ▶ To remove the head rest **1**, pull it sharply past the end limit.

Activating and deactivating the seat heating and seat climate control

The active seat climate control allows the driver to stay cool and dry.



Fig. 103: Activating and deactivating the seat heating and seat climate control

- | | |
|---|-----------------------------------|
| 1 Seat heating ON | 2 Seat air conditioning ON |
| 0 Seat heating and seat air conditioning OFF | |

To activate the seat heating:

- ▶ Move the switch to seat heating ON **1**.
 - ▷ The seat heating is activated.

To activate the seat climate control:

- ▶ Move the switch to seat air conditioning ON **2**.
 - ▷ The seat climate control is switched on.

To deactivate the seat heating and seat climate control:

- ▶ Move the switch to seat heating and seat air conditioning OFF **0**.
 - ▷ The seat heating and seat climate control is deactivated.

Adjusting the lumbar support

The lumbar support improves seat comfort and can be individually adapted by adjusting the bulge in the top and bottom of the back upholstery.

LBH/11002115/09/06-2013/en

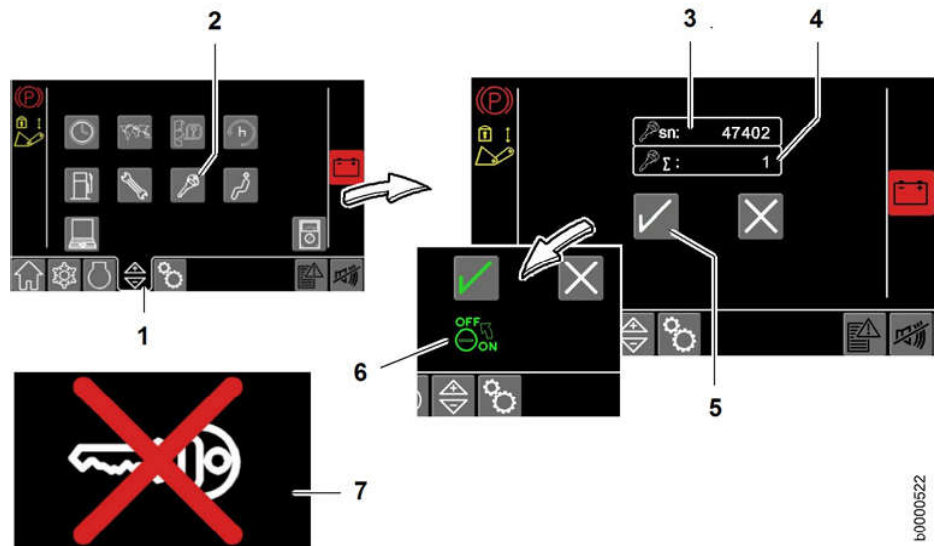

Fig. 119: Programming new starting keys

- | | | | |
|---|--|---|-----------------------------|
| 1 | Settings switching button | 5 | Program starting key button |
| 2 | Electronic driver interlock button | 6 | Switch off ignition display |
| 3 | Master key serial number display | 7 | Non-programmed key display |
| 4 | Number of already programmed keys (incl. master key) display | | |

- ▶ Press button 5.
 - ▷ Button 5 is green.
 - ▷ The display 6 flashes green.
- ▶ Switch off the ignition.
- ▶ Remove the master key.
- ▶ Switch on the ignition with the new starting key that is yet to be programmed.
 - ▷ When the display 7 disappears the starting key is programmed.

To programme further starting keys the entire process must be repeated:

- ▶ Switch on the ignition using the starting key.
- ▶ Press the *Settings* and *Electronic drive interlock* switching buttons to open the display screen.
- ▶ Press button 5.
 - ▷ Button 5 is green.
 - ▷ The display 6 flashes green.
- ▶ Switch off the ignition.
- ▶ Remove the master key.
- ▶ Switch on the ignition with the new starting key that is yet to be programmed.
 - ▷ When the display 7 disappears the starting key is programmed.

Deleting programmed starting keys

Only the master key is authorised to delete the starting keys. The delete process deletes **all** starting keys which have been programmed!

Using the master key, switch on the ignition and open the display screen using the switching buttons *Settings* and *Electronic drive interlock*.

b0000522

LBH/11002115/09/06-2013/en

Switching the interior lighting on and off

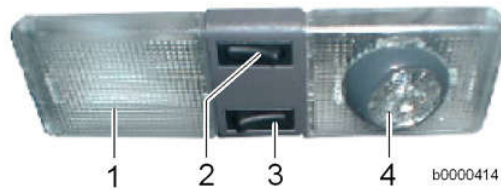

Fig. 132: Interior lighting

- | | |
|----------------------------|-----------------------|
| 1 Interior lighting | 3 Reading lamp switch |
| 2 Interior lighting switch | 4 Swivel reading lamp |

- ▶ Press the switch 2.
 - ▷ The interior lighting is switched on or off.
- ▶ Press the switch 3.
 - ▷ The reading lamp is switched on or off.

3.2.18 Display unit

The display unit is a touch screen display.

The grey switching buttons are for changing the screens and selecting functions.

The display is divided into the following sections:

- Status symbol indicator
- Warning symbol indicator
- Buttons for switching to the display and operation screens
- Display and operation screens



Fig. 133: Touch screen display

- | | |
|----------------------------|--|
| 1 Status symbol indicator | 3 Display and operation screen switching buttons |
| 2 Warning symbol indicator | 4 Display and operation screens |

LBH/11002115/09/06-2013/en

Selected blower speed indicator



bbb00928

- The blower speed is shown on a bar indicator.

Reduce the blower speed



bbb00923

- Switches off the heating and air conditioning system.
- Reduces the blower speed.

- 6 blower speeds
- Bar indicator on display
- The status is indicated with LEDs on the button on the control unit

Overview of units

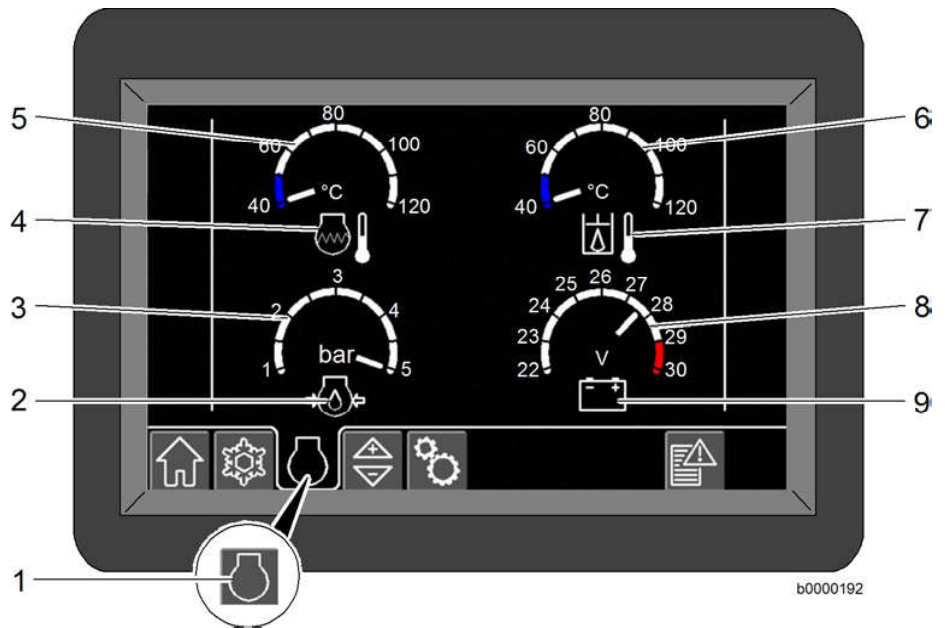

b0000192

Fig. 182: Overview of units

- | | | | |
|---|------------------------------------|---|-------------------------------------|
| 1 | Overview of units switching button | 6 | Hydraulic oil temperature indicator |
| 2 | Engine oil pressure symbol | 7 | Hydraulic oil temperature symbol |
| 3 | Engine oil pressure indicator | 8 | Battery voltage indicator |
| 4 | Coolant temperature symbol | 9 | Battery symbol |
| 5 | Coolant temperature indicator | | |

Overview of units switching button



b0000177

For switching to the overview of units display

LBH/11002115/09/06-2013/en

3.2.19 Mechanical hour meter

This equipment is optional.



Fig. 202: Hour meter

The mechanical hour meter 1 is in the instrument panel to the right of the driver's seat.

Machine service hours indicator

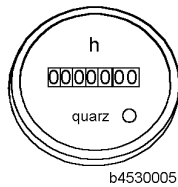

Mechanical hour meter

Shows how many hours the machine has been in operation.

The service hours are used as the basis for the maintenance intervals.

**Note**

The memory function of the float position switch is optional.
The setting remains stored after the ignition is switched off.

► This means the function is active when the ignition is switched on again.

Rear window heater and mirror heater (optional)

bbb00575

Rear window heater and mirror heater (optional) button

Switches the rear window heater and mirror heater (optional) on and off.

This function is only available when the ignition is on.

When you press the button for the first time:

- Function ON
- All three LEDs on the button light up

When you press the button a second time:

- Function OFF
- All three LEDs on the button go out

The function remains active after it is switched on:

- Until the rear window heater and mirror heater (optional) is switched off
- Or for a maximum 20 minutes (to protect the battery)

Rear windscreen wiper and washer system

bbb00576

Rear windscreen wiper and washer system button

Switches the windscreen wiper and washer system for the rear window on or off.

Press the button once:

- Intermittent wipe
- The LED on the left lights up

Press the button a second time:

- Constant wiping on
- The LEDs on the left and right light up

Press the button a third time:

- Function deactivated
- All the LEDs go out

Hold the button down:

- Rear windscreen washer pump ON
- Rear wiper ON
(Continues wiping for several seconds)

Controlling the optional attachment

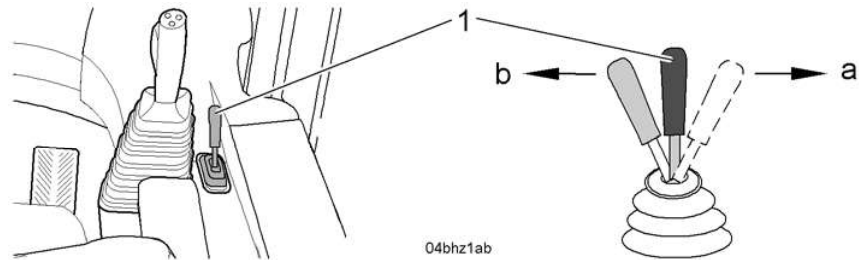

Fig. 253: Directions of movement of the additional control lever

a - Back

b - Forward

- ▶ You can control the optional attachment using the additional control lever **1**. Movements of the additional control lever and associated functions:
 - ▷ **a** - (function depends on the type of optional equipment attached)
 - ▷ **b** - (function depends on the type of optional equipment attached)

Make sure you are familiar with the operation of the additional equipment attached.

- ▶ (For more information see: [3.3 Operation, page 169](#)) or the operating manual for the additional equipment.

3.2.24 Heater/air conditioner

Switch the heater on or off using the blower speed button.



Note

The air conditioning system can only be activated or deactivated using the display unit.

- ▶ The full settings for the heating and air conditioning system can be configured using the display unit. (For more information see: [Heater/air conditioner, page 118](#))

You can use the buttons on the control unit to make the following settings:

- Temperature regulation
- Blower speed
- Fresh or recirculated air
- Defrost mode

The selected settings are briefly shown in the display.

Function of the LEDs

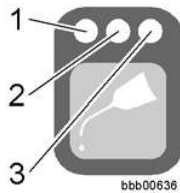

The functions of the central lubrication system are indicated by the LEDs on the central lubrication system button.

- LED 1 - light-duty operation
- LED 2 - medium-duty operation
- LED 3 - heavy-duty operation

LED	Function
One LED lights up	Mode 1, 2 or 3 has been set
One LED flashes	Pump is lubricated in mode 1, 2 or 3
All 3 LEDs light up	Grease reservoir is empty
All 3 LEDs flash	Fault in the central lubrication system

Tab. 18

Lubrication, cycle and idle times

The main electronics system (MASTER) controls the central lubrication system.

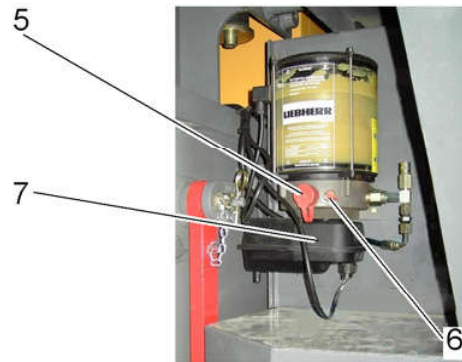
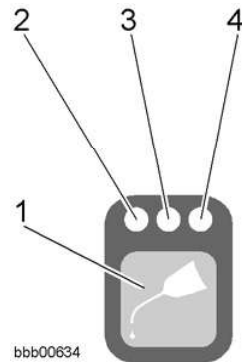

Fig. 271: Automatic central lubrication system

- | | |
|---|-----------------------------------|
| 1 Central lubrication system button | 5 Filling coupling (fast filling) |
| 2 Left LED - mode 1 (light-duty operation) | 6 Grease fitting |
| 3 Middle LED - mode 2 (medium-duty operation) | 7 Central lubrication pump |
| 4 Right LED - mode 3 (heavy-duty operation) | |

All further lubrication cycles follow automatically in a pattern determined by the current setting.

During lubrication, if the ignition is switched off (engine stop) or the parking brake is engaged, the controller stops lubrication.

After starting the engine and releasing the parking brake, lubrication is continued at the point where it was interrupted.

LBH/11002115/09/06-2013/en

- ▶ Push off the cap 2.
- ▶ Release the tank lock and remove the tank cap.
- ▶ Refuel with diesel fuel as necessary.
- ▶ If possible, refuel at the end of the working day to prevent condensation from accumulating in the tank.

The machine is ready for operation.

3.3.2 Starting the engine



Fig. 289: Operating manual

- 1.) Make sure you have read and understood the operator's manual
- 2.) Then you are ready to use the machine

Only ever operate the machine once you have read and understood the operating manual.



Note

The machine is equipped with a hydrostatic travel drive.

- ▶ You cannot start the engine by bump-starting it or towing it.

Starting precautions

The following precautions must be taken before starting the machine.

First make sure that the machine is in its operating position ([For more information see: Operating position, page 169](#)).



Note

If the machine has an electronic immobiliser:

- ▶ Only deactivate the immobiliser using the appropriate programmed key.

Starting procedure

Make sure that the following requirements are fulfilled:

- The machine is in the operating position.
- You have fastened your safety belt.

Switch on the ignition.

- ▶ Switch on the electrical system by turning the ignition key to position I.
 - ▷ The master electronics are booted up.



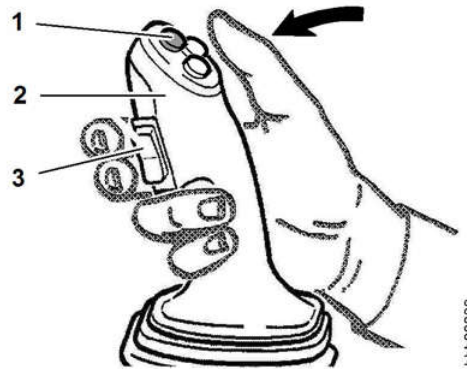

Fig. 311: LH control lever

- 1 LH control lever
- 2 Kick-down button
- 3 Travel direction switch

Kick-down shifting is used in the following situations:

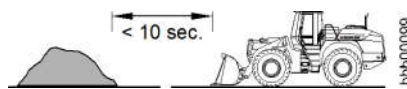

Fig. 312

a) When approaching the pile

- This allows you to work on the pile in first gear. The kick-down function hydrostatically brakes the machine, and it switches down to first gear. While pushing into the pile, first gear remains selected as long as the resistance is high. Kick-down mode is deactivated when you change travel direction.

If you want to use kick-down shifting:

- ▶ Press the kick-down button **2** on the LH control lever **1**.

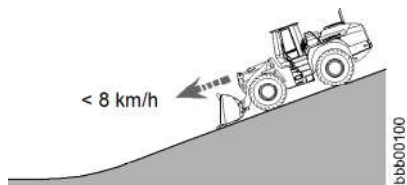

Fig. 313

b) Driving onto a steep downhill slope

- Before driving onto a steep slope, you can also use the kick-down function to shift to travel range I (first gear). The machine remains in first gear until you press the gas pedal. In kick-down mode, the maximum travel speed is 8 km/h.

If driving on a long, steep downhill slope:

- ▶ First activate kick-down mode.
 - ▷ The machine is automatically hydrostatically braked and the main electronics (MASTER) switches to first gear.
 - ▷ At high travel speeds, the machine automatically shifts from third to second gear, and then to first gear.
 - ▷ The machine remains in first gear until you press the gas pedal.
 - ▷ When you press the gas pedal, the main electronics (MASTER) automatically switches to second and third gear.

LBH/11002115/09/06-2013/en

CLICK HERE TO **DOWNLOAD** THE COMPLETE MANUAL

- Thank you very much for reading the preview of the manual.
- You can download the complete manual from: www.heydownloads.com by clicking the link below



- Please note: If there is no response to CLICKING the link, please download this PDF first and then click on it.

CLICK HERE TO **DOWNLOAD** THE COMPLETE MANUAL

**DANGER**

There is a risk of accidents if the machine rolls away.

- ▶ Set the machine down on level ground.

Lowering the working attachment

Make sure that the bucket is empty.

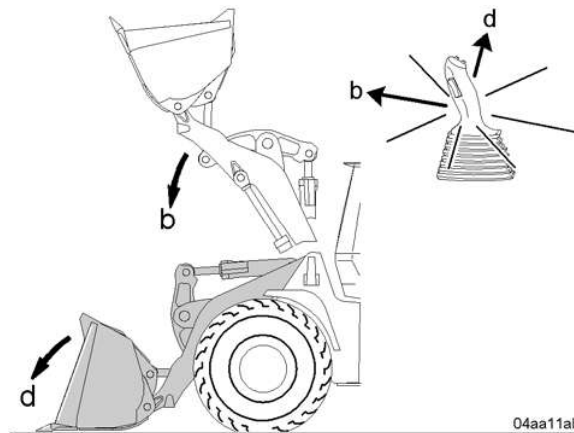

Fig. 336: Bucket arm movement

- ▶ Lower the lift arms by moving the control lever in direction **b**.
- ▶ Set down the bucket flat on the ground by moving the control lever in direction **d**.

Switching off the engine

NOTICE

There is a risk of damaging the engine

This is especially important with turbo engines.

If you suddenly switch off the motor, the turbocharger continues running for a while with no oil supply.

- ▶ Do not switch off the engine suddenly when it is running at full speed.

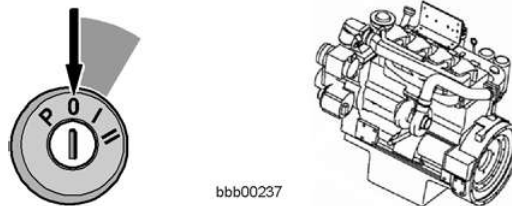

Fig. 337: Switching off the engine

- ▶ Reduce the engine speed to idle speed by taking your foot off the gas pedal.
- ▶ Let the engine continue idling briefly - for 10 to 15 seconds.
- ▶ Turn the ignition key to the **0** position and pull it out.
 - ▷ All the symbol fields go out.
 - ▷ Parking brake is engaged.

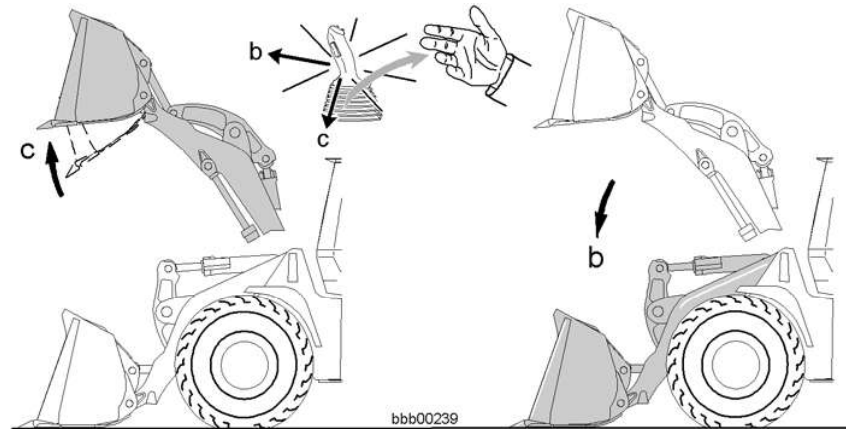

Fig. 359: Working movements

- ▶ Tilt in the loading bucket in the raised position by moving the LH control lever in direction **c** through the action point as far as it will go and releasing it.
 - ▷ The LH control lever is held in this position by magnetic force.
 - ▷ This moves the bucket into the preliminary position for the digging position.
 - ▷ As soon as the bucket reaches the preliminary position, the solenoid releases the LH control lever.
- ▶ Lower the lift arms by moving the LH control lever in direction **b**.
 - ▷ This moves the loading bucket into the digging position on the ground.

3.3.7 Diesel particulate filter

Function / operating conditions

The particulate filter integrated in the exhaust system reduces soot particles, hydrocarbons and carbon monoxide in the exhaust gas.

In normal operation the filter automatically cleans itself. The pre-requisite for this is achieving an exhaust gas temperature of above 250 °C over more than half of the operating time.

The exhaust counterpressure is recorded by the data logger. The data logger transmits the information via a data cable to the “diesel particulate filter” control unit in the driver's cab.

The following must be observed when operating at a sufficiently high exhaust temperature:

- ▶ Do not let the engine idle for a long period.
- ▶ Switch off the engine when the machine is not being used.
- ▶ Observe the control unit of the diesel particulate filter. If malfunctions are displayed the independent cleaning function of the filter is at risk. In this event take appropriate measures as quickly as possible. (For more information see: [Function test, page 203](#))

NOTICE

Unsuitable diesel fuel can damage the particle filter!

- ▶ Only use commercially available diesel fuels to operate the machine. Additives must not be added. (For more information see: [5.3.3 Diesel fuels, page 306](#))

- if lifted further, they tilt back out, but not forward.

The lever ratio of the kinematics in the topmost lifting range means that the load bearing capacity may be restricted. (For more information see: 1.2.25 Attachment - forklift, page 37)

This is how to work in forklift mode.

Make sure that the working attachment and the quick-change device are safely locked. (For more information see: 3.5 Fitting and removing the attachment, page 231)

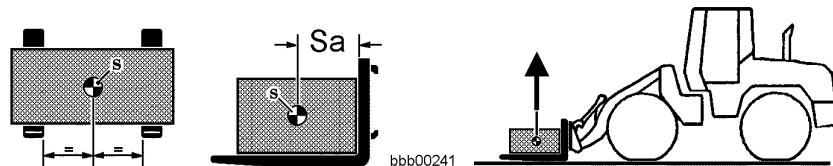

Fig. 369: Distance from centre of gravity

S Centre of gravity

Sa Distance from centre of gravity

NOTICE

There is a risk of damage to the load and the machine.

During forklift operation, only use forks with prongs of suitable length and make sure that these do not project beyond the load. Otherwise goods or pallets lying in front of the forks could be damaged.

- ▶ Avoid incorrect operation during forklift operation.

When you pick up the load, make sure that the load is resting as close as possible to the vertical limb of the fork prong.

- ▶ Pick up the load. Make sure that the centre of gravity **Sa** of the load is correctly positioned.



WARNING

There is a risk of the machine tipping over.

- ▶ Avoid incorrect operation during forklift operation.
- ▶ Raise the lift arms to the transport position (30-40 cm above the ground).
- ▶ When driving unloaded, tilt the forklift slightly in and carry it low.
- ▶ When driving with a load, tilt the forklift slightly in and carry the load low.
- ▶ When driving on slopes, always keep the load uphill.
- ▶ Never drive across slopes.
- ▶ Never turn on slopes.

If a high unloading position is required:

- ▶ Do not raise the lift arms until just before reaching the unloading point.

If a low unloading position is required:

- ▶ Do not lower the lift arms until just before reaching the unloading point.

3.3.11 Timber grabber

An optional attachment is available for transferring timber.

Scraping off material

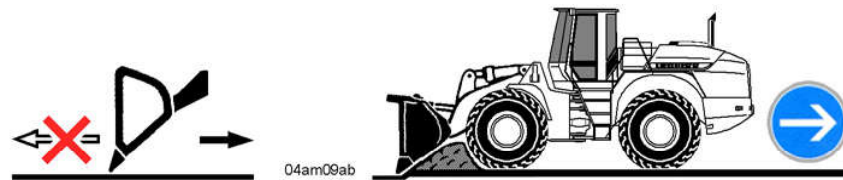

Fig. 384

- ▶ Tilt the bucket down and drive backwards.

3.4.4 Loading a heap

Picking up material

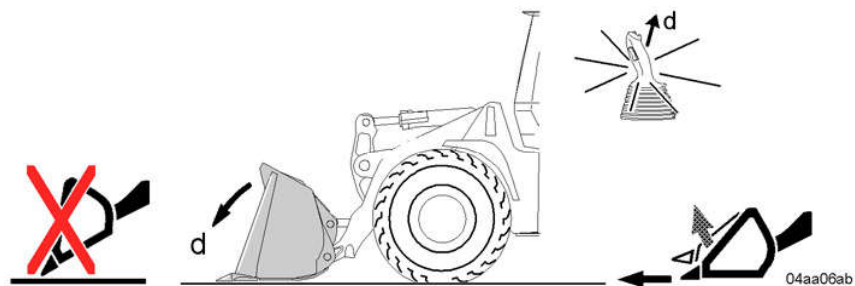

Fig. 385: Bucket position

NOTICE

There is a risk of damage to the machine.

The lift arms may be damaged if you hit a hard obstacle at speed when clearing away bulk material in the forward travel direction with the bucket tipped down.

- ▶ When clearing away bulk material, do not drive into the pile with the bucket tipped down.
-

- ▶ Lower the bucket horizontally to the ground.
- ▶ Drive into the material, slightly tipping the bucket in the process.

If you need to help the bucket penetrate the material:

- ▶ Gently tip the bucket up and down while driving into the material.
- ▶ Also press down the inch/brake pedal. (For more information see: [3.4.1 Picking up and moving material, page 217](#))

3.5 Fitting and removing the attachment

3.5.1 Operating the quick-change device with the control lever for additional working functions

The quick-change device is fitted on the front of the attachment holder and is used for changing the working attachment.

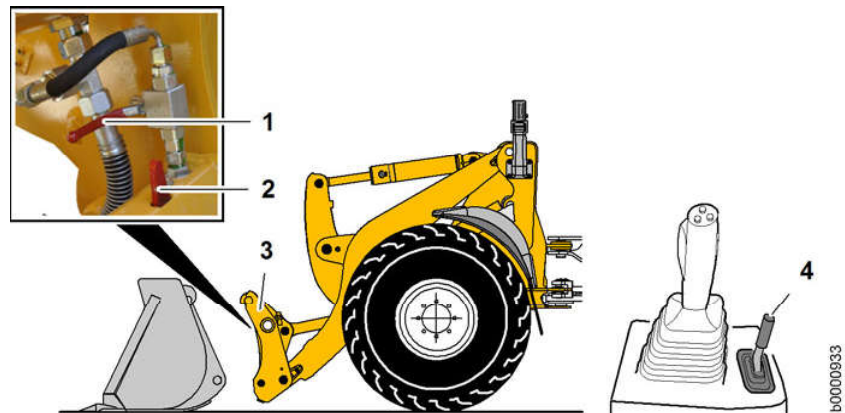

Fig. 407: Components of the quick-change device

- | | | | |
|---|----------------------------------|---|--|
| 1 | Quick-change device switch lever | 3 | Quick-change device ³⁶⁾ |
| 2 | Locking indicator | 4 | Control lever for additional working functions |



Note

No equipment or attachments of other makes may be installed or attached to the machine without prior written consent from Liebherr.

- ▶ The appropriate technical documentation should be made available to Liebherr for this purpose.

Removing the working attachment

Carry out the following steps:

1. Depressurising the operating circuits³⁷⁾
2. Disconnecting the hydraulic lines³⁷⁾
3. Activating the quick-change device
4. Unlocking and disconnecting the working attachment

Depressurising the hydraulics

If the working attachment has an independent hydraulic circuit, the hydraulic operating circuits must be depressurised.

³⁶⁾ Optional for lift arms with Z kinematics

³⁷⁾ If the working attachment has an independent hydraulic supply

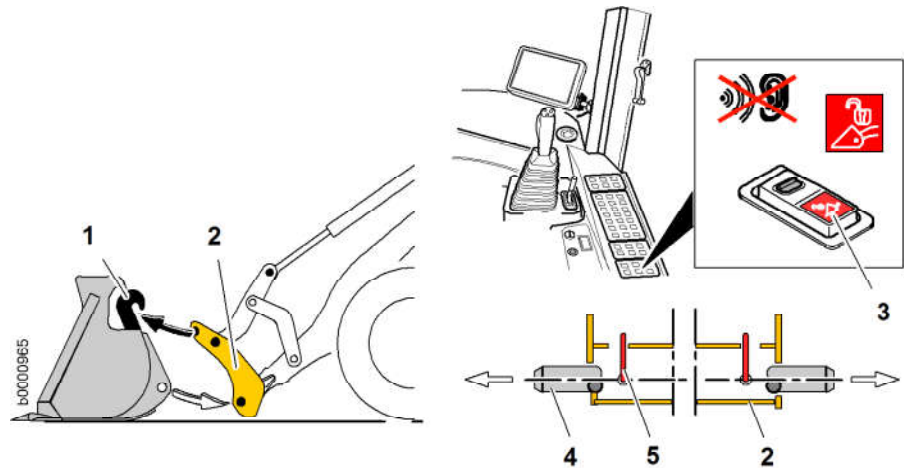

Fig. 419: Locking the working attachment

- | | |
|------------------------------|-----------------------------|
| 1 Working attachment holder | 4 Locking pin |
| 2 Quick-change device | 5 Locked position indicator |
| 3 Quick-change device button | |

- ▶ Carefully move the quick-change device 2 into the working attachment holder 1.
- ▶ Slightly raise and tilt in the working attachment.
 - ▷ The working attachment latches into the quick-change device.
- ▶ Press the button 3 and hold it down.
 - ▷ The warning tone stops.
 - ▷ The locking pins 4 of the quick-change device 2 are extended.

When the pins are completely extended:

- ▶ Release the button 3 again.
 - ▷ The working attachment is locked.

Checking that the working attachment is locked

The fact that you can change the attachment from the cab does not excuse you of the duty to check it afterwards. Every time you change the attachment, make a *visual inspection* and a *mechanical check* to make sure that the working attachment is correctly locked.



WARNING

Beware of the working attachment dropping.

- ▶ Do not carry out any working movements of the attachment before checking whether it is locked.

Visual inspection



Fig. 448: Transmission

- ▶ Reattach the plug **1** to the powershift section **2** of the transmission **3**.
 - ▷ This connects the solenoid valve on the gearbox to the electronics.
 - ▷ The machine's travel functions are operational again.

Towing with the engine not running

If the machine has suffered a serious breakdown such as engine failure, the braking and steering functions will be impaired.



Note

The brake accumulator is not filled if the engine is not running.

- ▶ The service brake becomes ineffective after it is applied several times.

The following precautions must be taken before towing the machine:

- Release the parking brake mechanically
- Have a suitable tow bar of sufficient strength ready

Releasing the parking brake mechanically:



Fig. 449



WARNING

There is a risk of accidents if the machine rolls away.

- ▶ Use the wedges to secure the machine against rolling away.

Service code	Effect	Cause	Remedy
M3000	STOP symbol field H24 flashes, no emergency steering function available	Emergency steering pump check pressure switch: shorted to earth	Contact LIEBHERR CUSTOMER SERVICE
M3001	STOP symbol field H8 flashes, no emergency steering function available	Emergency steering pump pressure switch: shorted to earth	Contact LIEBHERR CUSTOMER SERVICE
M3002	Brake system accumulator pressure symbol field H19 lights up, condition of the service brake cannot be detected	Brake system accumulator pressure switch: shorted to earth	Contact LIEBHERR CUSTOMER SERVICE
M3003	No float position available	Float position pressure switch: shorted to earth	Contact LIEBHERR CUSTOMER SERVICE
M3004	None	Inching angle sensor: channel 1 overcurrent >20 mA	Contact LIEBHERR CUSTOMER SERVICE
M3005	None	Inching angle sensor: channel 1 undercurrent <4 mA	Contact LIEBHERR CUSTOMER SERVICE
M3006	Travel direction cannot be selected	Travel direction switch: forward signal channel 1 shorted to earth	Contact LIEBHERR CUSTOMER SERVICE
M3007	Travel direction cannot be selected	Travel direction switch: reverse signal channel 1 shorted to earth	Contact LIEBHERR CUSTOMER SERVICE
M3008	No lift kick-out available	Lift kick-out inductive switch: shorted to earth	Contact LIEBHERR CUSTOMER SERVICE
M3009	No bucket return-to-dig available	Bucket return-to-dig inductive switch: shorted to earth	Contact LIEBHERR CUSTOMER SERVICE
M300B	Fuel filling level not detected - minimum filling level displayed	Fuel level sensor: voltage below 1 V	Check fuse F44 - contact LIEBHERR CUSTOMER SERVICE
M300C	Fuel filling level not detected - minimum filling level displayed	Fuel level sensor: voltage above 4 V	Contact LIEBHERR CUSTOMER SERVICE
M300D	Engine cannot be started	Ignition switch: start signal T 50a shorted to earth	Contact LIEBHERR CUSTOMER SERVICE
M300E	None	Gas pedal angle sensor: channel 1 overcurrent >20 mA	Contact LIEBHERR CUSTOMER SERVICE
M300F	None	Gas pedal angle sensor: channel 1 undercurrent <4 mA	Check fuse F44 - contact LIEBHERR CUSTOMER SERVICE

Service code	Effect	Cause	Remedy
M407E	Option not available	Direction 1 output signal (4th control circuit) - electrical fault at output (insufficient current)	Contact LIEBHERR CUSTOMER SERVICE
M407F	Option not available	Direction 1 output signal (4th control circuit) - electrical fault at output (excessive current)	Contact LIEBHERR CUSTOMER SERVICE
M4080	Option not available	Direction 1 output signal (4th control circuit) - electrical fault at output (deviation)	Contact LIEBHERR CUSTOMER SERVICE
M4081	Option not available	Direction 1 output signal (4th control circuit) - electrical fault at output (short circuit)	Contact LIEBHERR CUSTOMER SERVICE
M4082	Option not available	Direction 2 output signal (4th control circuit) - electrical fault at output (insufficient current)	Contact LIEBHERR CUSTOMER SERVICE
M4083	Option not available	Direction 2 output signal (4th control circuit) - electrical fault at output (excessive current)	Contact LIEBHERR CUSTOMER SERVICE
M4084	Option not available	Direction 2 output signal (4th control circuit) - electrical fault at output (deviation)	Contact LIEBHERR CUSTOMER SERVICE
M4085	Option not available	Direction 2 output signal (4th control circuit) - electrical fault at output (short circuit)	Contact LIEBHERR CUSTOMER SERVICE
M4086	Additional equipment 3 cannot be activated	Additional equipment 3: electrical fault at output (overcurrent/short circuit)	Contact LIEBHERR CUSTOMER SERVICE
M4087	Additional equipment 4 cannot be activated	Additional equipment 4: electrical fault at output (overcurrent/short circuit)	Contact LIEBHERR CUSTOMER SERVICE
M5022	Travel slow or impossible	Variable displacement motor balance failed	Contact LIEBHERR CUSTOMER SERVICE
M5026	Engine speed cannot be changed, driving not possible	Gas pedal angle sensor: values from sensors 1 and 2 are different	Check fuse F44, F45 - contact LIEBHERR CUSTOMER SERVICE
M5027	No inching function available	Inching angle sensor: values from sensors 1 and 2 are different	Check fuse F44, F45 - contact LIEBHERR CUSTOMER SERVICE
M5028	Speed limited to 20 km/h, driving only possible in 1st or 2nd gear	Gear oil temperature switch tripped: gear oil temperature above 120 °C, oil level too high or temperature switch defective	Clean cooling system, check oil level, contact LIEBHERR CUSTOMER SERVICE
M5029	No direct reaction	Rear axle brake error: rear axle brake activated for longer than 3 seconds at a time or for more than 16% intermittently	Contact LIEBHERR CUSTOMER SERVICE

LBH/11002115/09/06-2013/en

Fuse	Value	Unit	Designation/function	Location
5 - F01	100	A	Main fuse	Rear left of engine compartment

Tab. 25: Fuses in the engine compartment

- ▶ Use the table above to identify the defective fuse.
- ▶ Take out the defective fuse and replace it with a new one with the same rating.

Plug-in fuses on the relay and fuse board

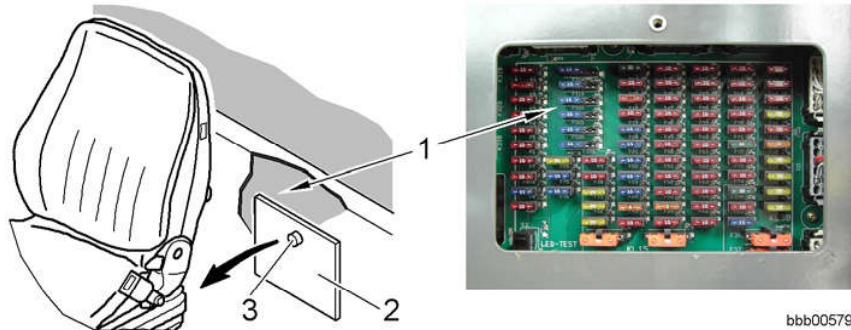

Fig. 462: Fuse box

- 1 Fuse box
- 2 Cover
- 3 Screw







The circuit board and the relay as well as the plug-in fuses are located behind the driver's seat.

5.2 Filling quantities and lubrication chart

Specifications in the quantity column:

- The values stated for the filling quantities in the table are only guidelines.
- The dipstick and level markings are always mandatory.
- Each time the oil is replaced or topped up, check the level in the unit in question.

5.2.1 Recommended lubricants

Description	Recommended lubricant	Symbol	Quantity
Engine (with filter change)	Liebherr Motoroil 10W-40 Liebherr Motoroil 10W-40 low ash Liebherr Motoroil 5W-30	 06sy05ab	43 l
Hydraulic system	Liebherr Hydraulic Basic 68 Liebherr Hydraulic Basic 100 Liebherr Hydraulic HVI Liebherr Hydraulic Plus	 06sy03ab	
System capacity			260 l
Tank capacity			135 l
Splitter box	Liebherr Gear Basic 90LS Liebherr Syntogear Plus 75W-90 Liebherr Hypoid 85W-140 EP	 06sy08ab	2.5 l
Transmission	Liebherr Hydraulic-Gear ATF 5W-20	 1 06sy14ab	11.5 l
Front axle	Liebherr Gear Basic 90LS	 2 06sy15ab	5 l
Rear axle	Liebherr Gear Basic 90LS	 3 06sy16ab	5 l

Tab. 27: Recommended lubricants

5.2.2 Recommended operating fluids

Description	Recommended operating fluid	Symbol	Quantity
Fuel tank	Conventional diesel fuel with sulphur content less than or equal to 0.5 %		350 l
Fuel reserve, approx.		bsym0057	35 l

LBH/11002115/09/06-2013/en



Note

If Liebherr coolant is not available at your location:

- ▶ Use coolant that meets the “coolant specifications for Liebherr engines” (consult customer service).



Note

Mixing different antifreeze and corrosion inhibitors can degrade the properties of the coolant.

- ▶ Do not combine different products.
- ▶ Never mix coolants with and without silicates, as this can damage the cooling system.

Corrosion inhibitors without antifreeze

In **exceptional cases** and if **ambient temperatures constantly remain above freezing point**, for example in tropical regions where there is demonstrably no authorised antifreeze and corrosion inhibitor available, prepare coolant by mixing water with the following inhibitors:

- **DCA 4 Diesel Coolant Additives**
- **Caltex XLI / Delo XLI / Texaco XLI / Havoline XLI**

In this case, change the coolant annually.

When carrying out maintenance tasks, test the concentration and adjust it as necessary.



Note

Mixing different corrosion inhibitors can degrade the properties of the coolant.

- ▶ Do not combine different products.
- ▶ Never mix coolants with and without silicates, as this can damage the cooling system.

If changing between corrosion inhibitor with and without antifreeze:

- ▶ Drain the coolant completely.

Product designation	Manufacturer
DCA 4 Diesel Coolant Additives	Fleetguard / Cummins Filtration
Caltex XLI / Delo XLI	Caltex (Asia)
Texaco XLI / Havoline XLI	Chevron (North and South America)
Havoline XLI	Arteco (Asia and Europe)

Tab. 37: Corrosion inhibitors without antifreeze

5.3.6 Hydraulic oil



The following oils may be used as hydraulic oils according to the following specifications.

Maximum water content of the hydraulic fluid: < 0.1 %

LBH/11002115/09/06-2013/en

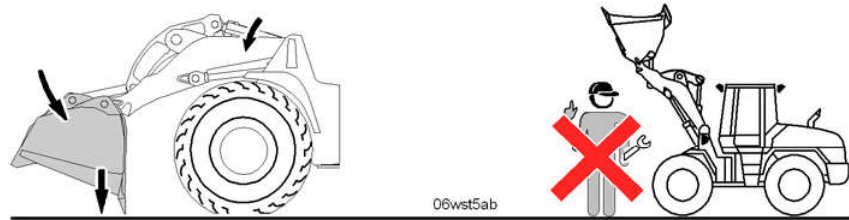

Fig. 484: Maintenance position 2

- ▶ Set the machine down on level ground.
- ▶ Engage the articulation lock.
- ▶ Lower the lift arms.
- ▶ Tilt the bucket out and set it down on the ground on its teeth or cutting edge.
- ▶ Engage the parking brake.
- ▶ Turn off the engine.
- ▶ Take out the starting key.
- ▶ Turn off the battery main switch.

5.4.3 Opening the service hatches, doors and hoods

Opening the engine compartment hatch

Open the hatch if you need to access the following units or components:

- Hydraulic pumps
- Hydraulic tank
- Hydraulic tank shut-off valve
- Air filter
- Battery main switch

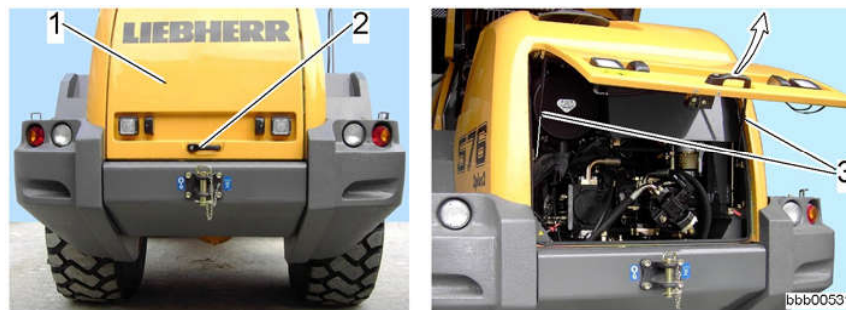

Fig. 485: Engine compartment hatch

- | | |
|---|------------------------------------|
| <p>1 Engine compartment hatch</p> <p>2 Handle with lock</p> | <p>3 Gas-filled springs</p> |
|---|------------------------------------|



CAUTION

There is a risk of injury if the flap falls shut.

- ▶ Check that the gas-filled springs securely hold the hood fully open.
- ▶ Open the lock with the ignition key.
- ▶ Completely open the hatch **1** with the handle **2**.

LBH/11002115/09/06-2013/en

- ▶ After 2 to 3 minutes, check the oil level on the dipstick.

Troubleshooting

Is the oil level between the min. and max. levels?

- ▶ Correct the oil level.
-

5.6.4 Checking the engine heating flange

Make sure that:

- The machine is in maintenance position 1.
- The engine compartment hood is open.
- You have an ohmmeter or a multimeter ready.

Procedure

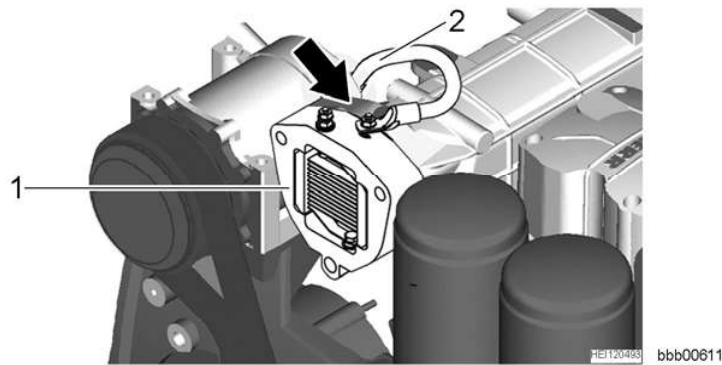

Fig. 497

- ▶ Turn off the battery main switch.
- ▶ Disconnect the electric connection cable 2 on the heating flange 1.
- ▶ Connect the ohmmeter or multimeter to the terminal and check the resistance.

Troubleshooting

If the resistance is not $0.25 \text{ ohm} \pm 10\%$ at $20 \text{ }^\circ\text{C}$:

- ▶ Replace the heating flange.
-
- ▶ Disconnect the electric connection cable on the heating flange.
 - ▶ Turn on the battery main switch

5.6.5 Changing the fuel pre-filter

On the right side of the engine you can find:

- Fuel pre-filter
with water separator
with fuel preheating, depending on the equipment of the engine (optional).
- Water level probe
- Integrated fuel hand pump.

Bleeding the water of the fuel prefilter must be conducted after the water level probe activates.

Procedure

Fig. 509: Air filter

- | | | | |
|----------|-------------------|----------|-----------------------|
| 1 | Secondary element | 4 | Fixing clips |
| 2 | Primary element | 5 | Dust extraction valve |
| 3 | Service cap | 6 | Air filter housing |

► Open the fixing clips **4** on the service cap **3** and take the cap off.

Remove the primary element **2** and the secondary element **1**.

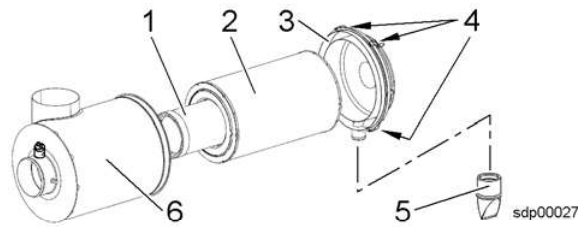
► To loosen the seal: pull or twist the elements slightly up, down or sideways.

Make sure that all dirt has been removed from the filter housing

► Before you put in a new or cleaned filter element.

► The secondary element **1** should be replaced every third time the main filter element **2** is replaced.

Before installing the filter elements, lightly oil the seal surfaces.

► (On the primary element **2** this is the inside, on the secondary element **1** it is the outside).

► Re-insert filter elements **1** and **2** and make sure that they are correctly fitted.

► Clean the service cap **3** and put it on the filter housing with the dust extraction valve **5** facing down.

Only when the lid completely covers the filter housing can you close the fixing clips without excessive force.

► Close the fixing clips **4**.

5.6.12 Changing the air filter secondary element

If the air filter contamination symbol field remains lit after the primary element **2** has been serviced then the secondary element **1** must also be replaced.

Change the secondary element:

- After replacing the primary element three times
- Otherwise, at least once a year

Make sure that the following requirements are fulfilled:

- The machine is in maintenance position 1.
- The engine compartment hatch is open.
- Appropriate protective equipment is used.

**CAUTION**

Beware of burns

- ▶ Do not touch the cooler units until they have cooled down.
- ▶ Swing out the fuel cooler **3**.

NOTICE

Risk of damage to the cooling system
Careless handling can damage the cooler fins.

- ▶ Do not use hard objects or excessive water pressure for cleaning.
- ▶ Clean the cooler units with compressed air, steam or water.
- ▶ Close the fuel cooler **3** again.
- ▶ Close the cooling system hood(s) (left/right) again.

5.9.3 Changing the coolant

Use clean, fresh water with a pH value between 6.5 and 8.5 and a low sulphate / chlorine content for preparing the coolant.

The coolant must be prepared outside the cooling system.

Always dispose of any coolant which you have drained off but no longer need, according to the applicable regulations.

Make sure that:

- The machine is in maintenance position 1.
- A receptacle with a minimum capacity of at least 25 litres is available for the used coolant, along with a drain hose.
- The mixing ratio of the new coolant must be correct. (For more information see: [5.9.1 Checking the coolant antifreeze and corrosion inhibitor concentration, page 345](#))
- The shut-off valves on the heating hoses are open.

5.13 Electrical system

Make sure that the following requirements are fulfilled:

- The machine is parked in a safe place.
- The electrical system of the machine is switched on.

5.13.1 Checking the indicator lamps

When you turn the ignition switch to the I position, the lamps on the display unit are tested. All symbol fields light up for three seconds.

- ▶ Check that the symbol fields on the display unit light up.

5.13.2 Checking the lights

All the lights can be tested without starting the machine. The machine only needs to be started when testing the reversing headlights.



WARNING

Beware of accidents when testing the lighting equipment with another person.

- ▶ Always maintain visual contact with the other person.
- ▶ Do not allow anyone into the danger area of the machine.



CAUTION

Beware of fires caused by the heat of the working floodlights.

- ▶ Observe the minimum interval of 1 m to persons and material.

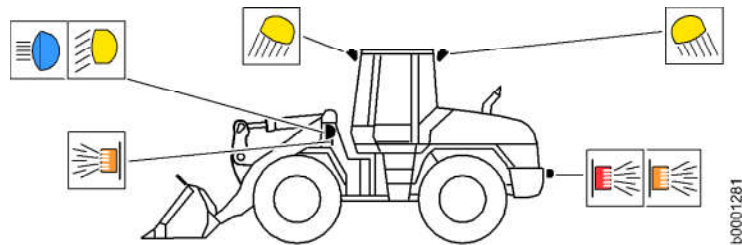

Fig. 534: Checking the lights

- ▶ Turn on all the lights.
 - ▶ Make a visual inspection.
- Checking the reversing headlights**
- ▶ Start the machine.
 - ▶ Select the “reverse” travel direction.
 - ▶ Make a visual inspection.

To adjust lights or replace defective lamps:

- ▶ Contact Liebherr customer service.

5.18 Cab, heating and air-conditioning

5.18.1 Greasing the cab door hinges

Make sure that the machine is in maintenance position 1.

Procedure



Lubricate the door hinges with a grease gun.

- Grease specifications:

5.18.2 Checking / topping up the windscreen washer reservoir

Make sure that the machine is in maintenance position 1.

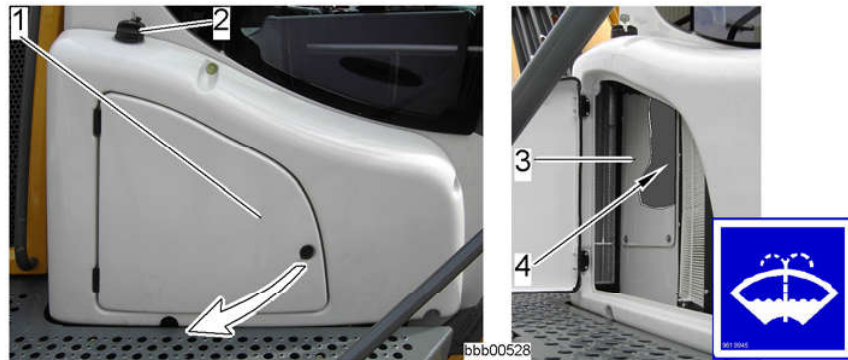

Fig. 551: Windscreen washer fluid reservoir

- | | | | |
|---|---------------|---|-----------------------------------|
| 1 | Door | 3 | Cover |
| 2 | Reservoir cap | 4 | Windscreen washer fluid reservoir |

The reservoir with filling inlet is mounted on the right-hand side of the driver's cab.

The filling quantity is approximately 3.5 litres.

- Unlock the cap on the reservoir and take it off.
- Top up with standard windscreen washer fluid as necessary.

NOTICE

Ice can damage the windscreen wiper and washer system.

Icing up can damage the windscreen wiper and washer system and cause it to fail.

- You must protect the windscreen wiper and washer system using antifreeze.



- Use commercially available windscreen antifreeze.
- Top up with an appropriate quantity of antifreeze before the winter starts.

NOTICE

There is a risk of damaging electrical devices.

When using a high-pressure cleaner, you may damage electrical devices such as the emergency steering pump, refuelling pump, sensors and electrical components in the cab.

- ▶ Do not expose electrical devices to water or steam jets.
-

- ▶ Wash the machine.
- ▶ Regrease all lubrication points on the machine.

Cleaning the engine

When washing the engine using water or steam jet, take care not to expose electronic devices such as the starter, alternator, sensors and oil pressure switches directly to the jet.

After cleaning, start up the engine to allow it to dry out.

NOTICE

There is a risk of damaging the engine and its electric components.

Moisture penetration can cause corrosion and electrical malfunctions.

- ▶ Do not expose devices such as the starter, alternator, sensors and oil pressure switches to water or steam jets.
-

- ▶ Carefully clean the engine.

CLICK HERE TO **DOWNLOAD** THE COMPLETE MANUAL

- Thank you very much for reading the preview of the manual.
- You can download the complete manual from: www.heydownloads.com by clicking the link below



- Please note: If there is no response to CLICKING the link, please download this PDF first and then click on it.

CLICK HERE TO **DOWNLOAD** THE COMPLETE MANUAL