



Model:

Serial number:



CLICK HERE TO **DOWNLOAD** THE COMPLETE MANUAL

- Thank you very much for reading the preview of the manual.
- You can download the complete manual from: www.heydownloads.com by clicking the link below



- Please note: If there is no response to CLICKING the link, please download this PDF first and then click on it.

CLICK HERE TO **DOWNLOAD** THE COMPLETE MANUAL

Contents

1	Product description	17
1.1	Type plate	17
1.2	Declaration of conformity	18
1.3	Intended use	19
1.4	Inappropriate use	20
1.5	Machine	21
1.5.1	Rotary drive	21
1.5.2	Rotary drive dimensions	22
1.5.3	Operating weight	22
1.5.4	Application conditions	23
1.5.5	Rotary drive	23
1.5.6	Safety devices	24
2	Safety instructions	27
2.1	Technical condition of the machine	27
2.2	Danger zone	27
2.3	Safety signs on the machine	28
2.4	Meaning of the safety signs	28
2.4.1	Mandatory signs	28
2.4.2	Prohibition signs	29
2.4.3	Warning signs	30
2.4.4	Rescue signs	32
2.4.5	Fire protection signs	33
2.5	Meaning of machine-specific signs	33
2.5.1	Safety signs	33
2.5.2	Notice signs	34
3	Control and operating elements	41
4	Operation	45

1.5 Machine

1.5.1 Rotary drive

The diagram below provides an overview of the machine components.

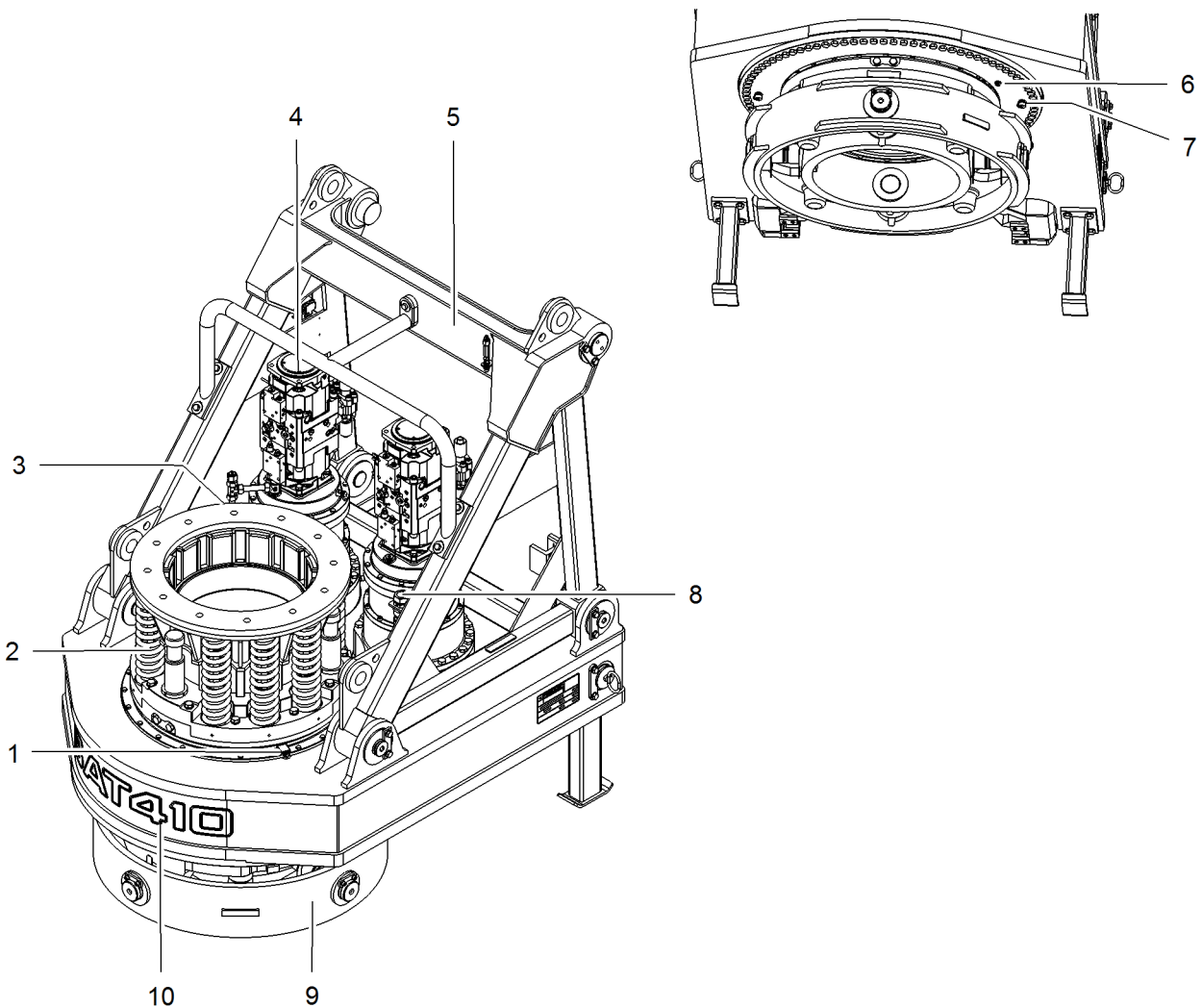

Fig. 2: Overview

1	Lubricating nipple cover screw	5	Rotary drive carriage	9	Universal joint
2	Kelly shock absorber	6	Lubricating nipple cover screw	10	Rotary drive
3	Oil inspection glass	7	Oil drain screw (2x)		
4	Hydraulic motors (2x)	8	Oil filler neck		

- Black rim
- Yellow background
- Black pictogram

Warning signs indicate risks or hazards.

General warning signs



Observe operation manual



Warning of non-ionizing radiation



Warning of obstacles on the ground



Warning of fall hazard



Warning of slipping hazard



Warning of electric voltage



Warning of suspended loads



Warning of hot surfaces



Warning of automatic start



Warning of crushing hazard



Warning of crushing hazard when falling



Warning of hand injuries

LWN/AZV01.01//2016-08-10/en

3 Control and operating elements

The section **Control and operating elements** deals with the following subjects:

- Alignment of control and operating elements
- Names of control and operating elements

The **Control and operating elements** of the exchangeable equipment are described in the machine's operating manual.



WARNING

Inadmissible or improper procedure!
Severe injuries, damage to machine.

If the operation manual contains insufficient information:

- ▶ Contact Liebherr customer service.
-

5 Operational faults, diagnosis

The **Malfunctions, diagnostics** section deals with the following subjects:
– Malfunctions of exchangeable auxiliary equipment and related diagnostics

The malfunctions and diagnostics of exchangeable auxiliary equipment are described in the machine's operating manual.



WARNING

Inadmissible or improper procedure!
Severe injuries, damage to machine.

If the operation manual contains insufficient information:

▶ Contact Liebherr customer service.

6.2.5 Locking washers

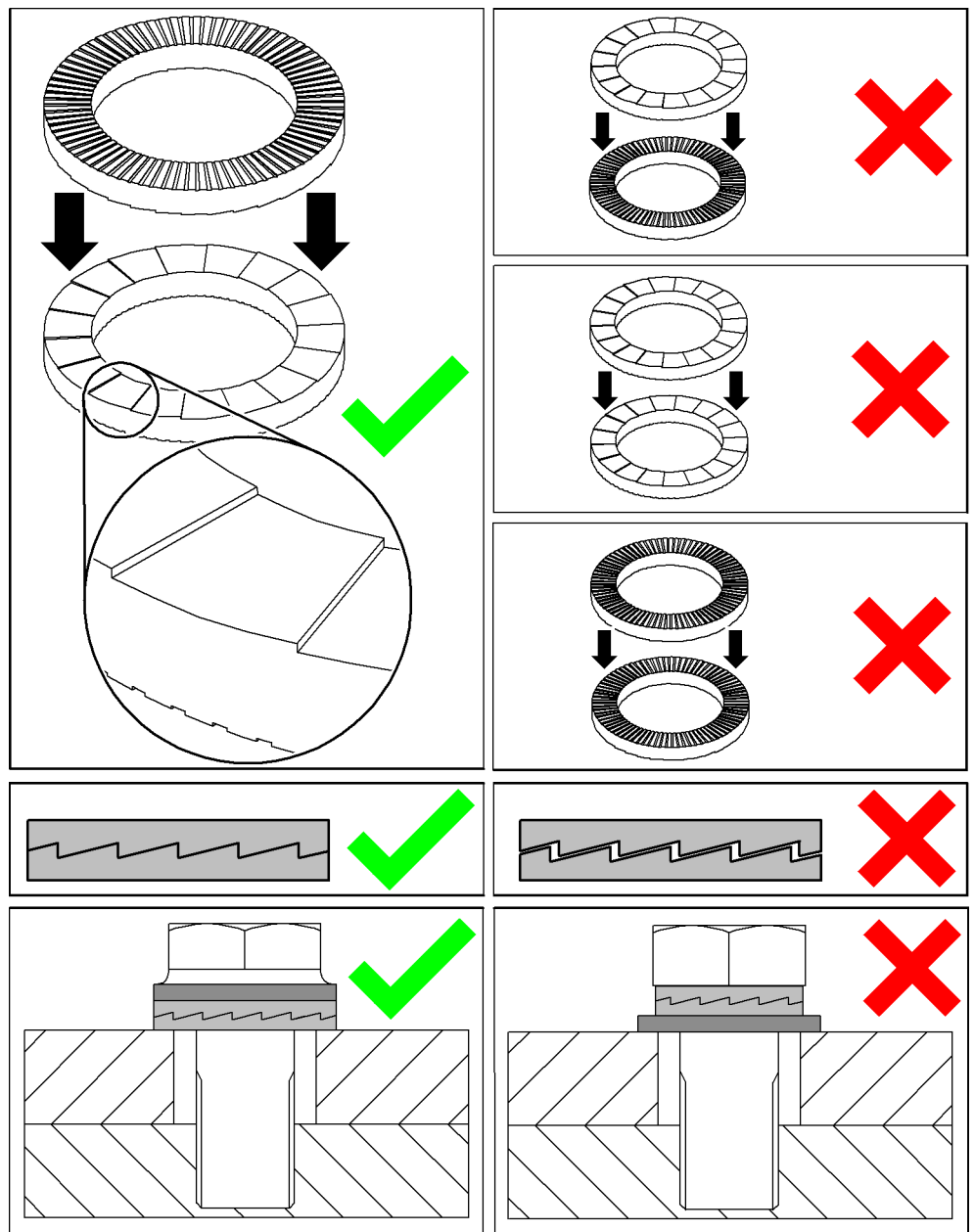

Fig. 103: Locking washers



WARNING

Improperly installed locking washers!
Screw connection detaches unintentionally.
Serious injury.

- ▶ Install locking washers properly.
- ▶ Tighten screw with specified torque.

Customer:.....Machine type:.....Serial no.:..... Operating hours:.....Date:.....

Maintenance / inspection after service hours								Tasks to be performed		
8h/Daily	40h/Weekly	500h/Quarterly	1000h/Every six months	2000h/Annually	4000h/2 years	6000h/3 years	Special intervals	By maintenance staff ■ Once-only activity ● Repeat interval † If necessary * Annually before the winter	By authorised specialist staff □ Once-only activity ○ Repeat interval † If necessary	See page
Rotary gearbox										
●								Checking the gearbox oil level		80
			●					Change gearbox oil for the first time after 200 operating hours		81
	●							Checking for leaks		82
	●							Checking fastening screws		82
●								Lubricate gearbox		83
Cam bar										
	●							Check driving rails for wear, weld on/exchange if necessary		84
	●							Check attachment elements of driving rails for tight fit		84
Kelly shock absorber										
●								Checking the hydraulic buffers		85
●								Check the Kelly shock absorber support ring		85
Accumulator*										
		□	○					Check accumulator		
				○				Changing the accumulator		

LWN/AZV01.01//2016-08-10/en

**CAUTION**

Hot gearbox components and gearbox oil!
Burns, open wounds.

- ▶ Maintenance work and inspection work must only be carried out when the rotary drive is switched off and has cooled down.
- ▶ Wear protective equipment.

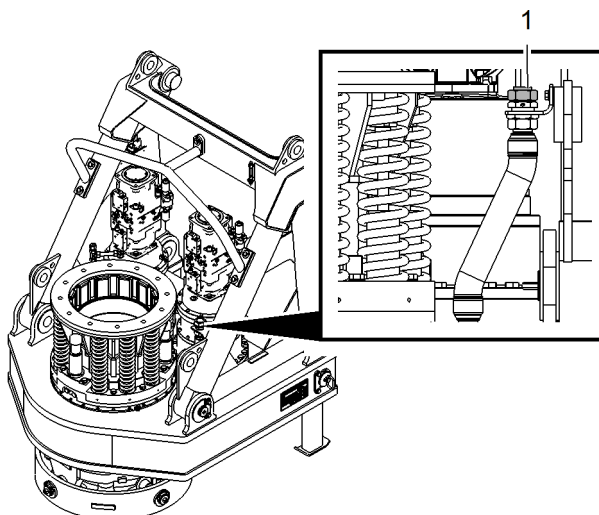

Fig. 106: Topping up gearbox oil

1 Oil filler screw

- ▶ Open oil filler screw 1.

NOTICE



Inadmissible or contaminated gearbox oil!
Damage to the rotary gearbox.

- ▶ Top up using only appropriate gearbox oil according to lubrication chart ([For more information see: 8.2.2 Lubrication chart, page 73](#)).
- ▶ Check purity of gearbox oil.
- ▶ Top up gearbox oil up to MAX mark.
- ▶ Close oil filler screw 1.

8.3.3 Draining the gearbox oil

Make sure the following prerequisites are met:

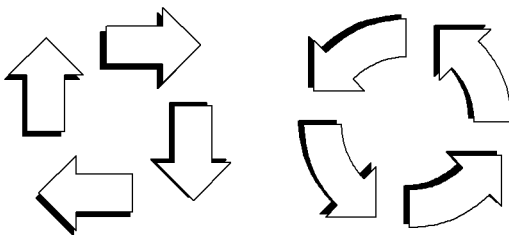
- The rotary drive has been switched off for 5 minutes.
- The rotary drive is level.
- Rotary drive is protected from unauthorized startup.
- Trap is present.

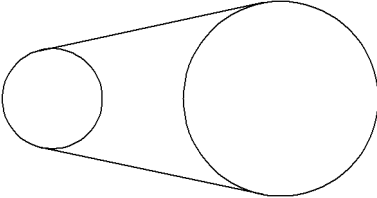
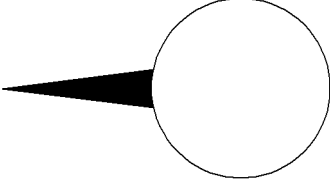
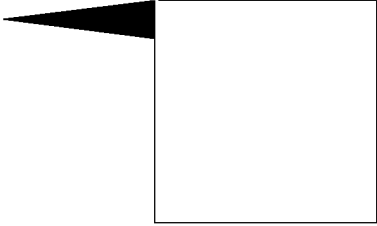
Symbol	Meaning
	Consequences of actions
	Consequences of actions with imperative sequence
	Consequences of actions with random sequence
	Exact enlargement of an area
	Enlargement of an area or a component in the same perspective as in the illustration
	Enlargement of an area or a component in a different perspective as in the illustration

Symbols in illustrations

Labeling of the warning notices

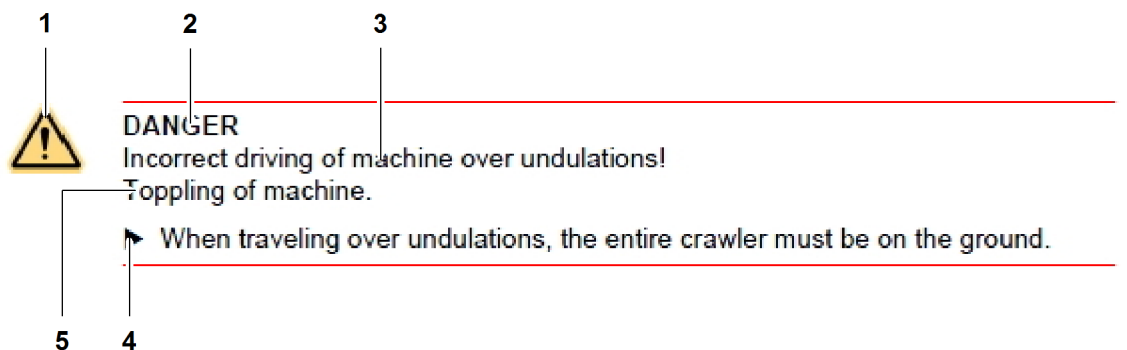

2.16.2	Special hand signals for sling gear application	182
2.16.3	Hand signals for lifting gear application in accordance with ASME/ANSI B30.5	185
3	Control and operating elements	193
3.1	Operating elements on undercarriage	193
3.2	Operating elements on the uppercarriage	194
3.3	Cabin	195
3.4	Left control lever	197
3.4.1	Function assignment buttons of left control lever	197
3.4.2	Function assignment movement direction of left control lever	199
3.5	Right control lever	202
3.5.1	Function assignment of right control lever buttons	202
3.5.2	Function assignment of right control lever movement directions	207
3.6	Foot pedals and hand levers	210
3.7	Circular bubble	211
3.8	Control panel X11	212
3.9	Control panel X12	214
3.10	Control panel X23	216
3.11	Control panel X25	220
3.12	<i>Concrete pump</i> control panel	225
3.13	Monitor	227
3.13.1	Status bar	227
3.13.2	Display section	233
3.13.3	Menu bar	233
3.13.4	Submenu bar	234
3.14	Start screen	236
3.15	Mode screen	237
3.15.1	Kelly drilling	237
3.15.2	CFA drilling	243
3.15.3	FOW drilling	248
3.15.4	Full displacement drilling	252
3.15.5	Soil mixing	257
3.15.6	Down-the-hole drilling	261
3.16	<i>Power unit</i> screen	266

9.2.9	Preservation medium (anti-corrosion coating)	762
9.2.10	Liebherr oil diagnosis system	764
9.3	Work instructions for preventive maintenance	767
9.4	Fuel tank (see operating manual of the engine manufacturer on CD)	769
9.4.1	Draining water and bottom sediments	769
9.5	Fuelling system* pressure filter	770
9.5.1	Exchanging the fuelling system pressure filter	770
9.6	Air filter system	771
9.6.1	Checking the function of the negative pressure indicator	771
9.6.2	Cleaning the air filter dust ejector	771
9.6.3	Exchanging the dry air filter main element and dry air filter safety element	772
9.7	Distribution gearbox	774
9.7.1	Checking the gearbox oil level	774
9.7.2	Topping up gearbox oil	774
9.7.3	Checking the venting valve	775
9.8	Swing	777
9.8.1	Checking the gearbox oil level	777
9.8.2	Topping up the gearbox oil	777
9.9	Rotary joint	779
9.9.1	Lubricating external teeth	779
9.9.2	Lubricating the bearing races via the central lubrication point	779
9.10	Feed winch	781
9.10.1	Checking the gearbox oil level	781
9.10.2	Topping up gearbox oil	782
9.10.3	Lubricating counter bearings	782
9.10.4	Checking the rope end fastening for tight fit	783
9.11	Auxiliary winch	784
9.11.1	Checking the gearbox oil level	784
9.11.2	Topping up gearbox oil	785
9.11.3	Lubricating counter bearings	785
9.11.4	Checking the rope end fastening for tight fit	786
9.12	Kelly winch	787
9.12.1	Checking the gearbox oil level	787
9.12.2	Topping up gearbox oil	788

1.3 Installation declarations*

The valid installation declaration is located right behind the cover sheet if the machine is delivered to an EU country. Additional documentation may also be enclosed like documents relating to a prototype test or an international acceptance test.

1.7.3 Technical data

Operating conditions

Ambient temperatures

Name	Value
Storage	-40 °C (-40 °F) to 40 °C (104 °F)
Operation	-20 °C (-4 °F) to 40 °C (104 °F)
Operation at low temperatures*	to -25 °C (-13 °F) (For more information see: 2.15.2 Operation of the machine down to -25 °C (-13 °F)*, page 178)
	to -40 °C (-40 °F) (For more information see: 2.15.3 Operation of the machine down to -40 °C (-40 °F)*, page 178)

Tab. 6: Technical data ambient temperatures

Application height

The exhaust gas turbocharger of the diesel engine reduces the influence of falling air pressure on the engine output at high altitudes. Still, a performance reduction is to be expected with the diesel engine when operating the machine at high altitude above sea level and at high air temperatures.

When using the machine at high altitudes above sea level: The engine control unit adjusts the engine characteristic curve automatically. A membrane located on the side of the control unit measures air pressure.

Emissions

Diesel engine exhaust gas volume

Name	Value
Diesel engine exhaust gas volume	see type label on diesel engine

Tab. 7: Technical data diesel engine exhaust gas volume

Noise measurement data

Name	Value
Guaranteed sound pressure level L_{PA} in cabin	78.2 dB(A) 78.2 db(A)

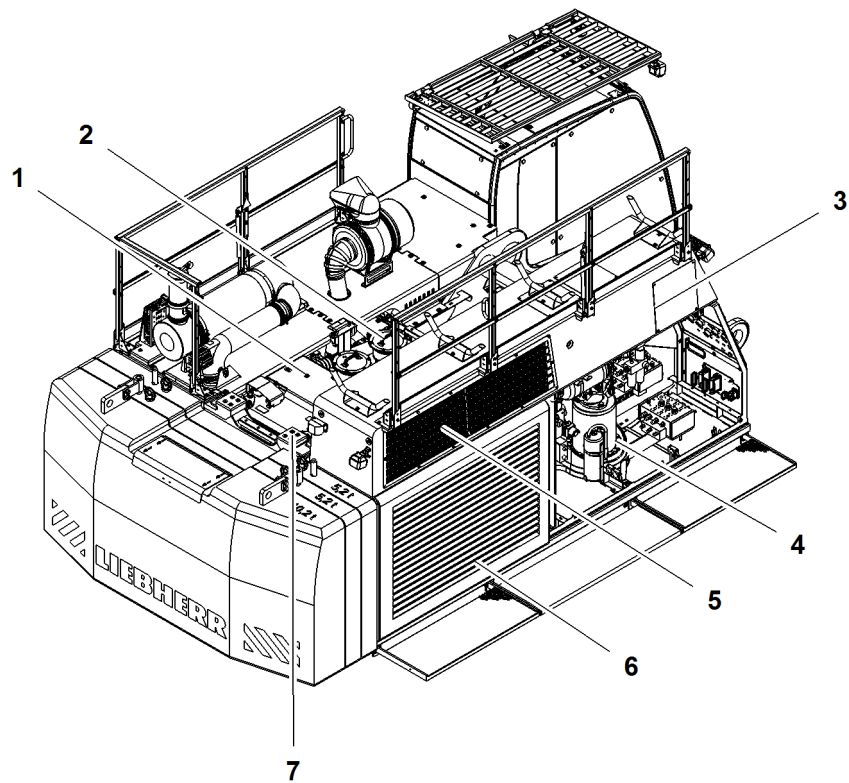

Fig. 11: Uppercarriage viewed from rear right

- | | | | |
|---|--------------------|---|-----------------------------|
| 1 | Fuel tank | 5 | Hydraulic oil cooler |
| 2 | Hydraulic oil tank | 6 | Water and charge air cooler |
| 3 | Compressor* | 7 | Leader support (2x) |
| 4 | Swing gear (2x) | | |

1.9.2 Leader

Leader overview

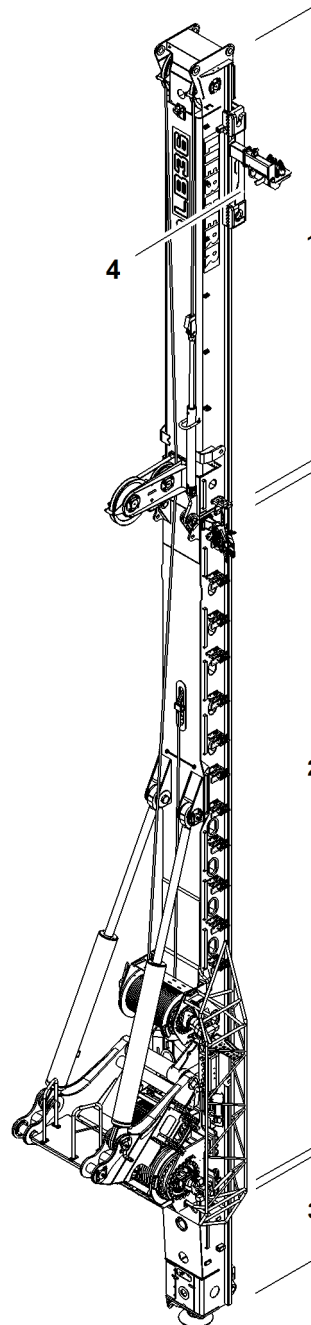

Fig. 22: Leader overview

- | | | | |
|---|-----------------------|---|-----------------------|
| 1 | Top part of leader | 3 | Bottom part of leader |
| 2 | Center part of leader | 4 | Universal carriage |

Leader top 1700 mm (5' 7" ft-in) drilling axis*

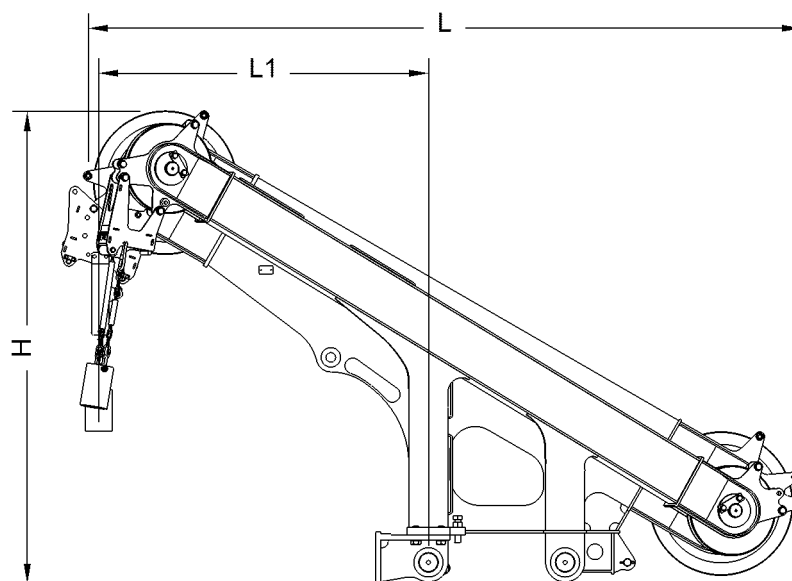

Fig. 36: Leader top 1700 mm (5' 7" ft-in)

Name		Value
H	Height	2422 mm 7' 11" ft-in
L1	Drilling axis distance	1700 mm 5' 7" ft-in
L	Length	3688 mm 12' 1" ft-in
	Weight	1741 kg 3,838 lb

Tab. 29: Technical data leader top 1700 mm (5' 7" ft-in)

1.11 By-pass flow filter system*

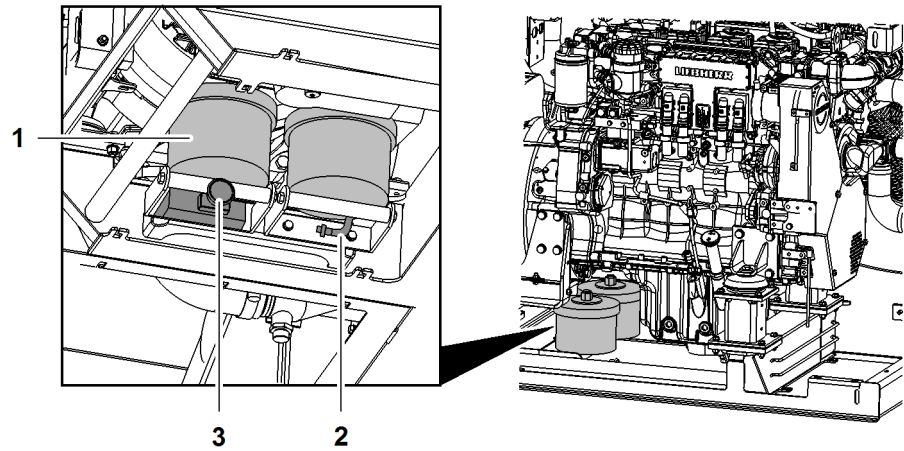

Fig. 47: By-pass flow filter system

- 1 Filter housing (2x)
- 2 Drain plug

- 3 Pressure gauge

1.17 Safety guard* for falling object protection

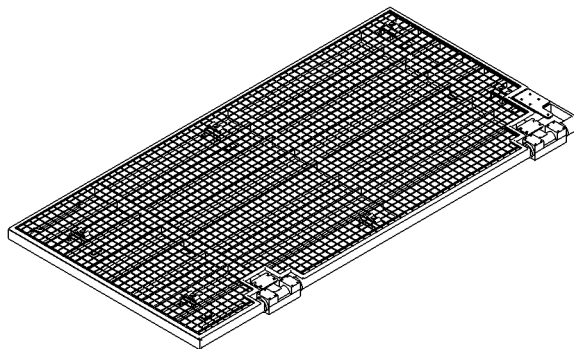

Fig. 56: Safety guard for falling object protection

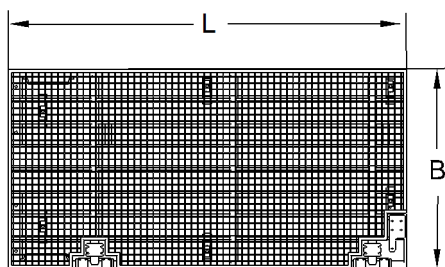

Fig. 57: Dimensions safety guard for falling object protection

Name		Value
B	Width	940 mm 3' 1" ft-in
H	Height	1880 mm 6' 2" ft-in
Weight		9.5 kg 20.94 lb

Tab. 35: Technical data safety guard for falling object protection

1.19.7 Left rear cover

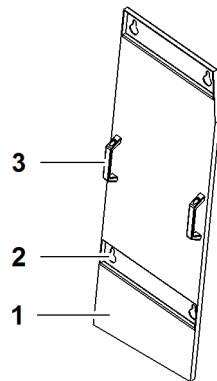

Fig. 73: Left rear cover

- 1 Left rear cover
- 2 Suspension equipment (4x)
- 3 Carrier handle (2x)

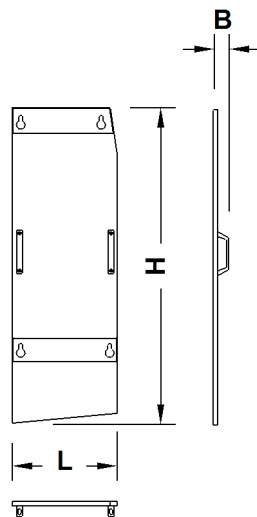

Fig. 74: Dimensions left rear cover

Name		Value
L	Length	425 mm 1' 5" ft-in
B	Width	63 mm 2.48" in
H	Height	1280 mm 4' 2" ft-in
Weight		5 kg 11.02 lb

Tab. 43: Technical data left rear cover

1.21 Socket* in cabin

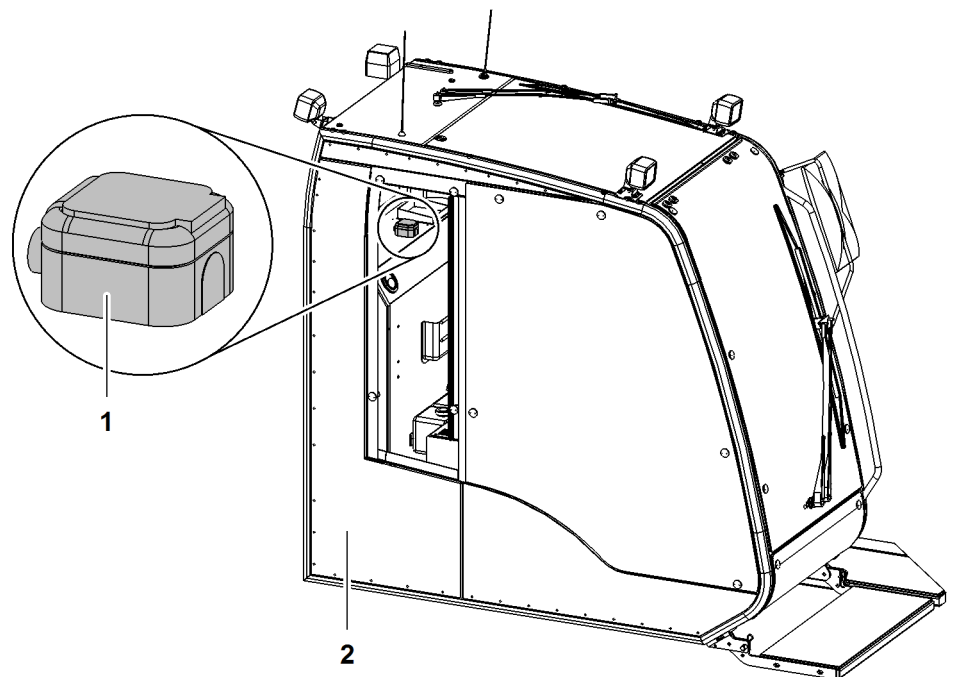

Fig. 86: Socket* in cabin

1 Socket

2 Cabin

The socket for mains voltage is installed in the cabin on the back shelve.

To operate the socket in the cabin, the external power supply retrofit kit is required additionally.

The socket is only ready for operation with plugged in external power supply.

1.29 Obstacle warning light*



Note

National or regional regulations may require the use of the obstacle warning light!

- ▶ Before using the machine, familiarise yourself with national and local regulations.

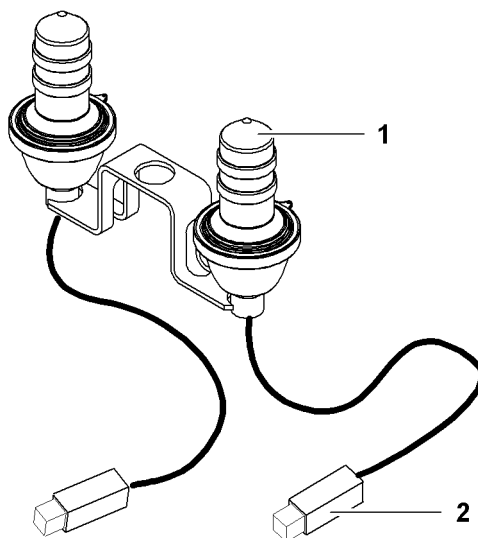

Fig. 93: Obstacle warning light

1 Obstacle warning light (2x)

2 Plug (2x)

The obstacle warning light:

- is attached onto the same fixture as the anemometer.
- is lit when the button *Obstacle warning light* is activated.
- lights up if an external power supply is connected.

Spare parts

Only Liebherr spare parts may be used.

Repairs

If major repairs must be carried out on part of the machine, it is important to strictly observe the correct working instructions specified by the manufacturer. If the manufacturer's instructions are not available, an specialized engineer must define the work instructions.

2.2 Areas of responsibility

2.2.1 Manufacturer

The manufacturer has the following responsibilities:

- He is responsible for the operationally safe state of the machine including accessories and documentation at the time of transfer to the owner.
- He observes his product monitoring obligation and documents all preventive maintenance and repair work carried out by Liebherr service personnel.
- He ensures operational state of machine through a worldwide servicing and repair service.
- He operates a training center and offers training to operating and maintenance personnel as a service to the owner.

2.2.2 Owner

The operator which can also be the owner has the following responsibilities:

- He ensures that the machine is operated and maintained by trained personnel only.
- He provides the necessary protective equipment to all persons involved in lifting or working with the machine.
- He checks personnel at regular intervals for safety-conscious working.
- He is responsible for the operationally safe state of the machine including accessories and documentation from handover by the manufacturer.
- He notifies the manufacturer of any accident involving the machine, which resulted in serious injuries or major property damage.
- He appoints Liebherr service personnel according to the preventive maintenance and inspection plan.
- He gives Liebherr service personnel unrestricted access to the machine with regard to the product monitoring obligation.
- He does not carry out any alterations on the machine without consulting the manufacturer.
- He uses original Liebherr spare parts only.
- He contacts the Liebherr customer service if the information in the operating manual is insufficient.

If the work is not carried out by the owner, he ensures that his areas of responsibility are contractually transferred to the organization that carries out the work.

The owner designates an "appointed person" for monitoring the machine's use.

2.6.3 Danger zone in transport position

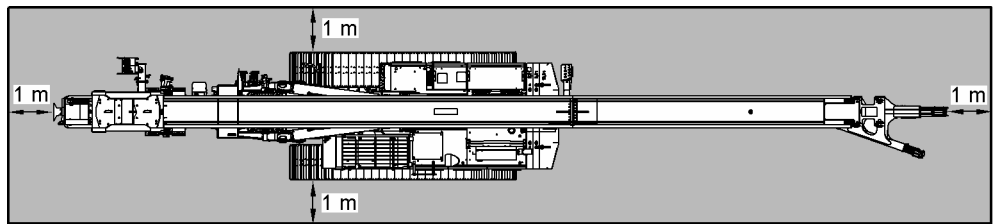

Fig. 103: Danger zone in transport position

2.7 Safety signs on machine



WARNING

Missing, damaged or illegible safety signs!

- ▶ Check safety signs to ensure they are complete and legible.
- ▶ Replace missing or illegible safety signs with new, original ones.

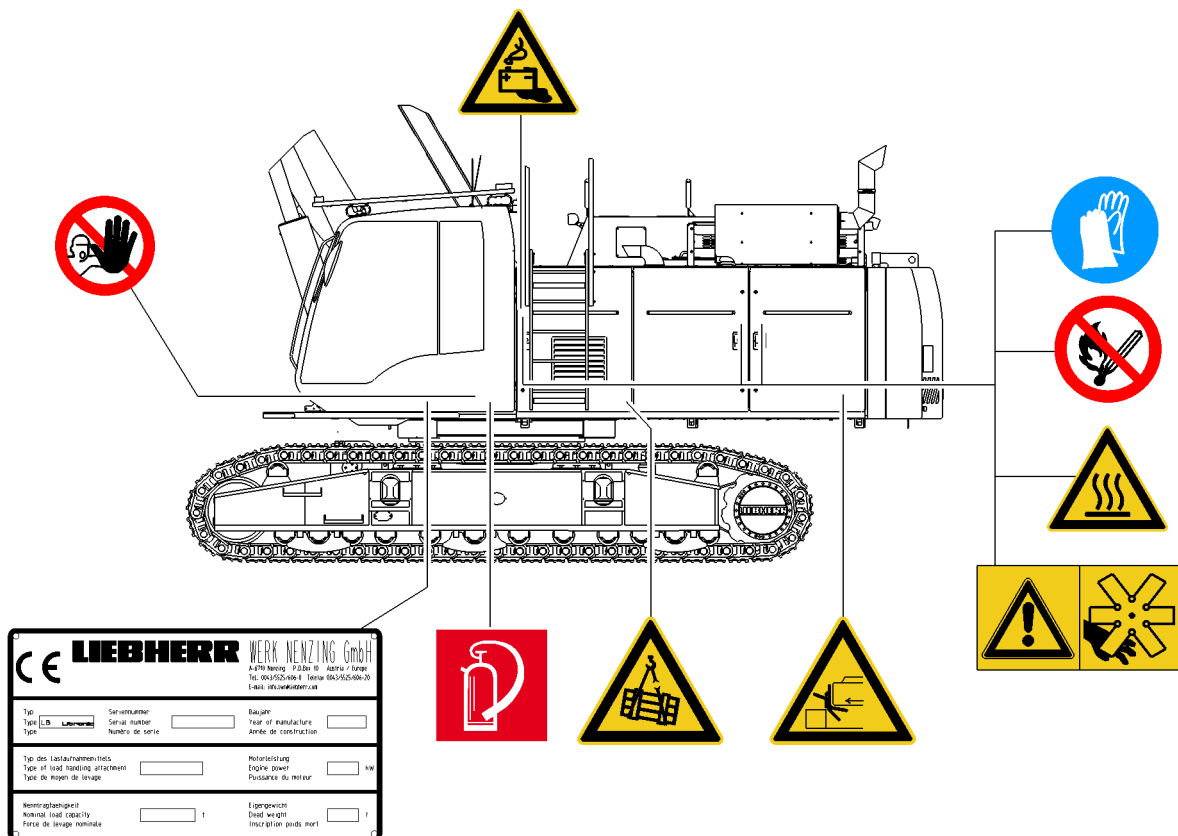

Fig. 104: Safety signs on left side of machine



No access for unauthorized personnel



Warning of crushing hazard

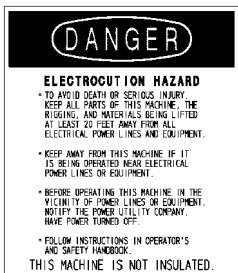

Warning indicating dangerous electrical voltage



Warning of bodily injury

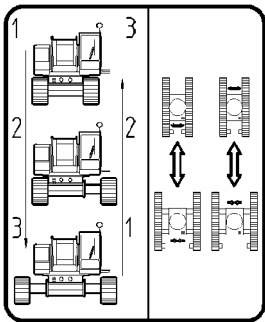

Track width adjustment

2.11 Notice signs



Fueling up with diesel

- A) Wind speed $v(d)$ at 10 m (32' 10" ft-in) height (top limit of the Beaufort stage) averaged over 10 minutes.
 B) Height z above level ground.
 C) Speed $v(z)$ of a 3 second wind gust acting at height z decisive for the calculation.

2.12.10 Snow load and ice load



DANGER

Snow or ice on the machine!
Structural breakdown.

- ▶ Observe handling-specific and situation-specific safety notes.



WARNING

Falling chunks of snow and ice!

- ▶ Never work with a machine that is iced up or covered in snow.



Note

Observe the following safety notes:

- ▶ Lay down drilling rig and carefully remove any large accumulations of snow and ice.
- ▶ Remove snow and ice from all sensitive parts such as limit switches, guides, etc.
- ▶ Snow and ice loads increase the drilling rig weight and the area exposed to wind.

2.12.11 Load-bearing capacity of the ground



DANGER

Ground has a limited load-bearing capacity!
Toppling of machine.

- ▶ Implement work planning.
- ▶ Observe handling and situation-specific safety notes.



Note

Observe the following safety notes:

- ▶ Have values for permitted ground pressure determined by officially certified specialists.
- ▶ Calculate applied ground pressure for using the machine in work planning. Observe the values in the foreword of the valid load chart or request the necessary data from the manufacturer.
- ▶ Use excavator support mats if required.
- ▶ Compact ground if necessary.



DANGER

Inadmissible condition of ground!
Toppling of machine, breaking of base plates, increased wear of base plates.

- ▶ Ensure that each base plate has full ground contact.

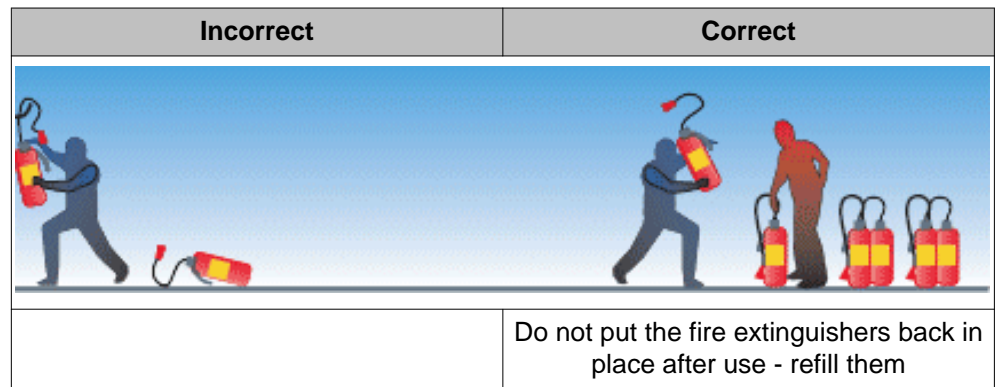

Tab. 59: Use of the fire extinguisher

2.14 Working at heights



WARNING

Working at heights without precautions!
Fall from machine.

- ▶ Only perform work on the machine on the ground.

If work at heights is necessary:

- ▶ Secure yourself against falling.
- ▶ Observe international and national regulations.



Note

Liebherr recommends:

- ▶ When working at heights use suitable working platforms.

2.15 Use at low temperatures

The following measures must be performed and all requirements and conditions fulfilled when operating Liebherr duty cycle crawler cranes, crawler excavators and deep foundation machines at low temperatures.

Prerequisites for start-up at sub-zero temperatures:

- Ensure unobstructed view from the cabin. The cabin's windows are clean and the mirrors properly adjusted.
- Check that snow and ice have been removed from the cabin, uppercarriage, crawler side frames, platforms, limit switches, ropes, drums, pulleys, load, and also, where possible, from the booms and/or leader and accessory equipment.
- Sling gear is approved for the prevailing ambient temperatures.
- Load rigging points are approved for the prevailing ambient temperatures.
- Load drop-off site can safely bear the load and is permitted for the prevailing outdoor temperatures.

Conditions for operation at sub-zero temperatures:

- Use antifreeze.
- Heat machine to operating temperature.

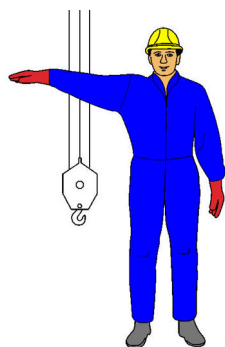
**Rotate**

- Extend right arm horizontally
- Palm faces down
- Extended finger points in rotation direction

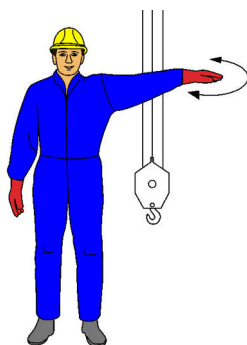
**Stop**

- Extend one arm horizontally
- Palm faces down
- Move arm back and forth horizontally

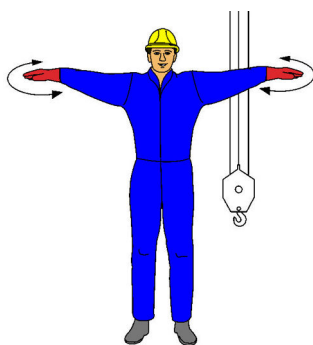
**Emergency stop**

- Extend both arms horizontally
- Palms face down
- Swing both arms back and forth horizontally

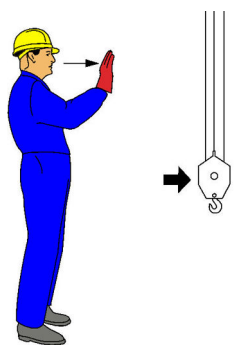
**Travel**

- Angle one arm
- Palm faces forward
- Make a motion in the direction of travel with one open hand

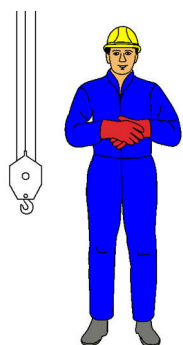
**Park and secure machine**

- Hook hands in front of your body

3.4 Left control lever

3.4.1 Function assignment buttons of left control lever

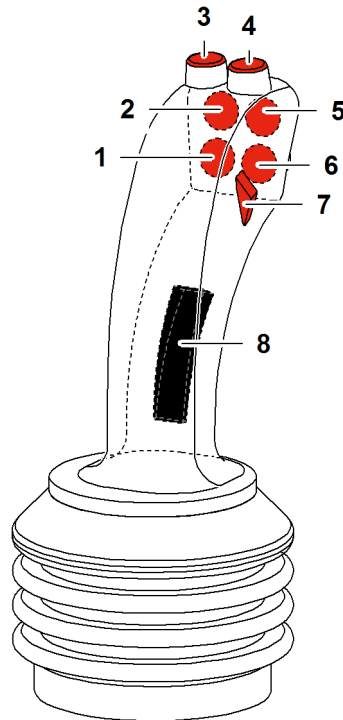

Fig. 256: Function assignment buttons of left control lever

Button	Mode	Preselection or additional button	Name and function
1	All modes		Leader support* Activate leader support adjustment.
2	All modes		Leader tilt Activate leader tilt adjustment.
3	All modes		Kelly winch free-wheel Activate Kelly winch free-wheel.
4	All modes		First automatic leader adjustment Activate first automatic leader adjustment.
5	All modes		Leader radius Activate leader radius adjustment.
6	All modes		Second automatic leader adjustment Activate second automatic leader adjustment.
7	All modes		[not used]

3.5.2 Function assignment of right control lever movement directions

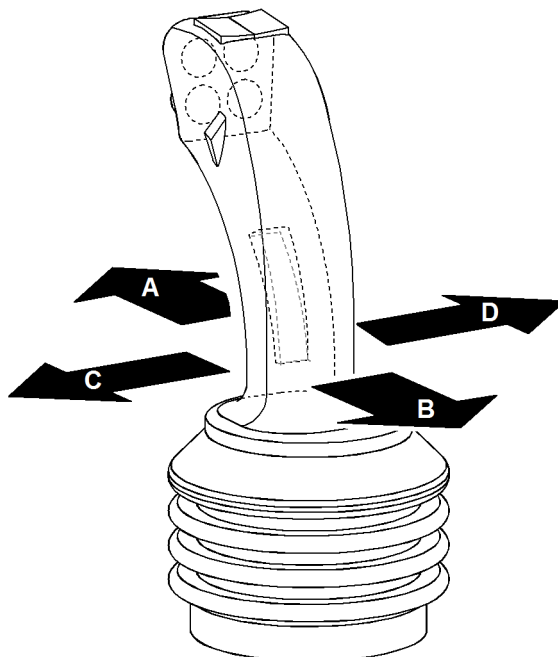

Fig. 304: Function assignment of right control lever movement directions

Movement direction	Mode	Preselection or additional button	Function
A	All modes		Lower universal carriage.
B	All modes		Raise universal carriage.

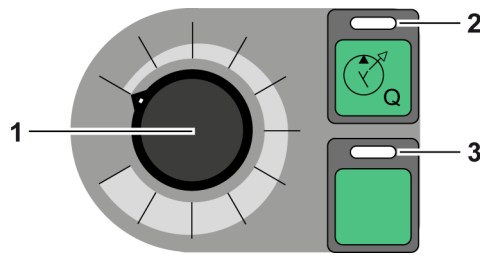

Fig. 342: Control unit Delivery rate casing oscillator*

- 1 Rotary control knob Delivery rate casing oscillator*
- 2 LED of the button Delivery rate casing oscillator*
- 3 LED of the button [not assigned]



Delivery rate casing oscillator*

Button not assigned.

LED of the button Delivery rate casing oscillator 2 is lit if the rotary control knob 1 of the control unit Delivery rate casing oscillator is active and controls the delivery rate of the casing oscillator*.

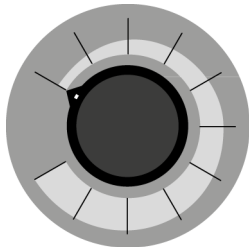

Delivery rate casing oscillator*

Increases or decreases the delivery rate of the casing oscillator.



Unsecured free-wheel

Activate or deactivate unsecured free-wheel.
Maintaining free-wheel for Kelly winch.



Swing speed

Setting the speed level of the swing.



Closing the clamping collar (external)*

Close clamping collar (external).



Opening the clamping collar (external)*

Open clamping collar (external).



Casing oscillator*

Turn the casing oscillator on or off.



Reinforcement vibrator* - closing the clamp

Close clamp.

3.13 Monitor

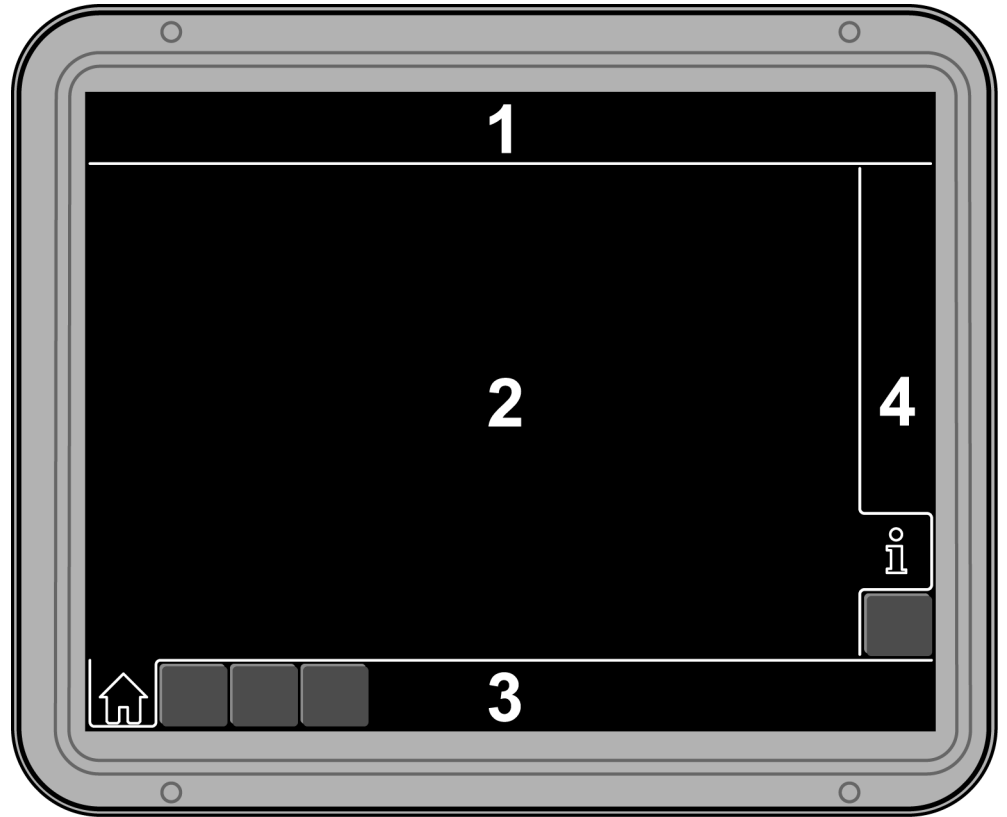

Fig. 401: Monitor sections

- | | | | |
|---|-----------------|---|-------------|
| 1 | Status bar | 3 | Menu bar |
| 2 | Display section | 4 | Submenu bar |

3.13.1 Status bar

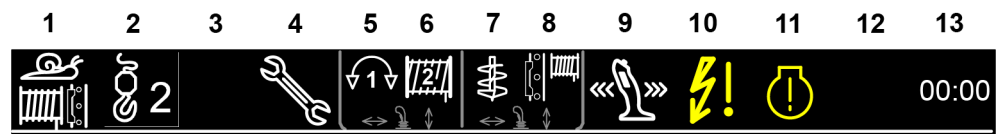

Fig. 402: Status bar - positioning

Position 1



Crawl speed feed winch

Crawl speed feed winch is activated.

Position 2



Kelly winch free-wheel

Kelly winch free-wheel is activated.

3.15 Mode screen



Operation

Switches to the *Operation* screen.

The *Operation* screen informs the machine operator about the most important information during operation.

3.15.1 Kelly drilling

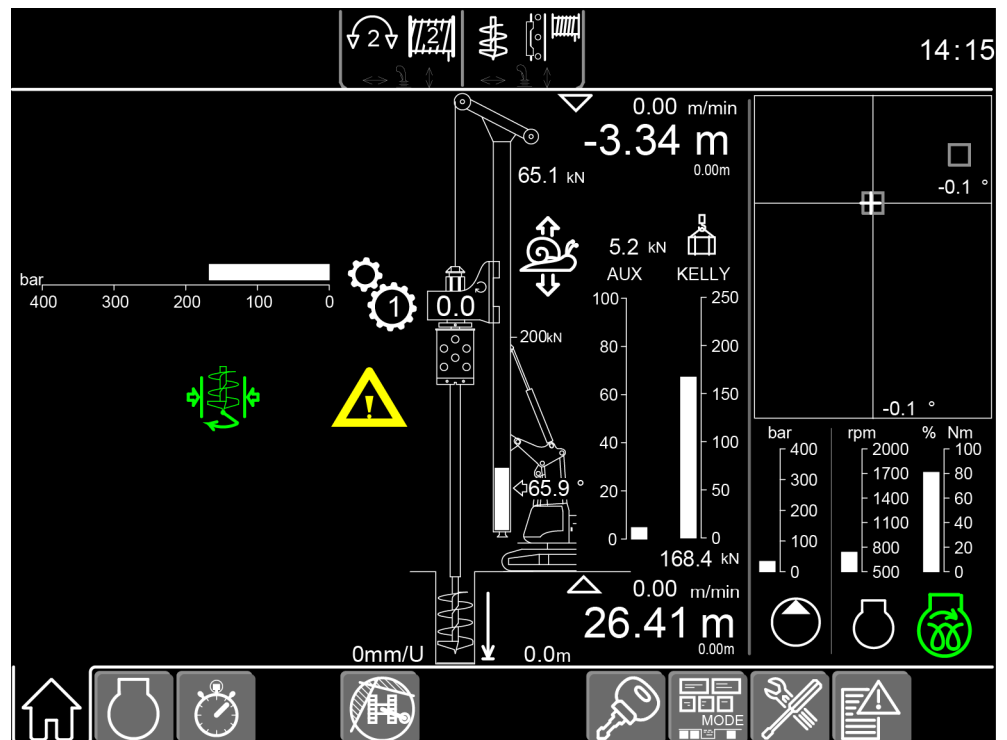

Fig. 494: Operation - Kelly drilling screen

**Overdrive (with BA*) and/or speed range2 (with BAT)**

Overdrive (BA) and/or speed range2 activated on right control lever.

**Speed range3 (with BAT)**

Speed range3 activated on right control lever.

**Speed range4 (= minimum torque with BAT)**

Speed range4 (= minimum torque with BAT) is activated on right control lever.

**Rotary drive warning (lit yellow)**

Warning threshold of rotary drive exceeded. Pay attention to error message on *Error message* screen.

**Stop rotary drive (blinks red)**

Deactivate rotary drive right away.

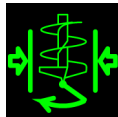
**Torque limitation active (lit green)**

Torque limitation is activated.

**Torque limitation inactive (lit yellow)**

Torque limitation is deactivated.



Speed range4 (= minimum torque with BAT)

Speed range4 (= minimum torque with BAT) is activated on right control lever.



Rotary drive warning (lit yellow)

Warning threshold of rotary drive exceeded. Pay attention to error message on *Error message* screen.



Stop rotary drive (blinks red)

Deactivate rotary drive right away.

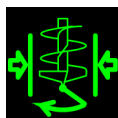

Torque limitation active (lit green)

Torque limitation is activated.



Torque limitation inactive (lit yellow)

Torque limitation is deactivated.

3.15.5 Soil mixing

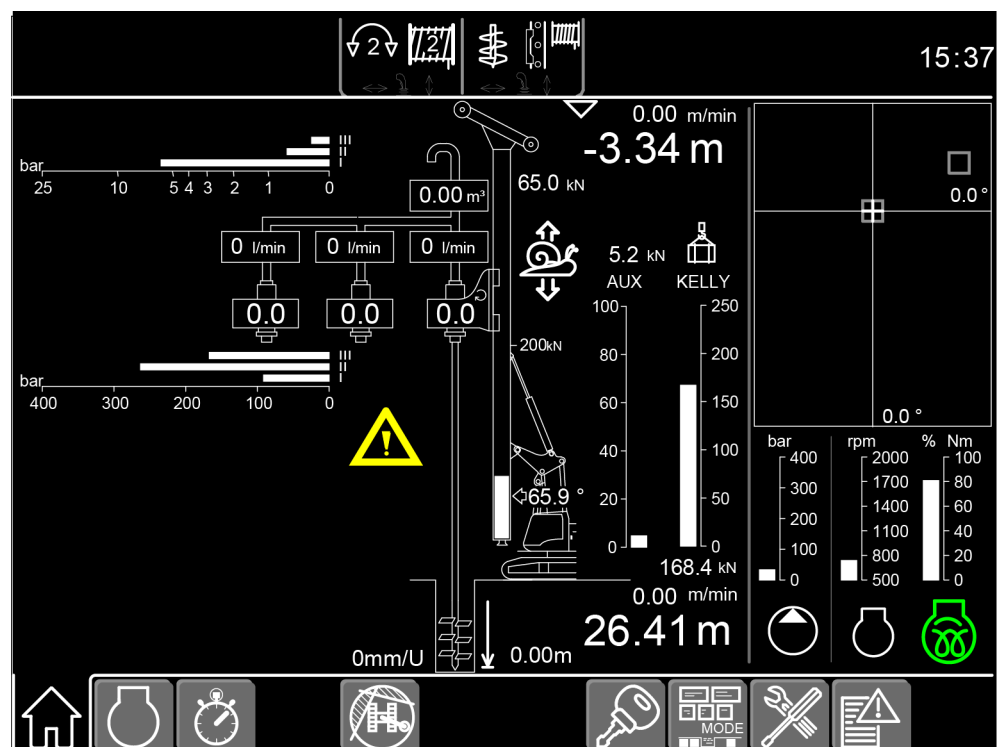
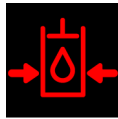
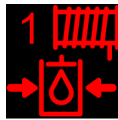

Fig. 580: Screen Operation - Soil mixing

**Supply pressure** (blinks red)

Supply pressure is too low.

**Supply pressure winch1** (blinks red)

Feed pressure on winch1 is too low.

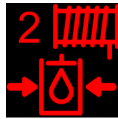
**Feed pressure winch2** (blinks red)

Feed pressure on winch2 is too low.

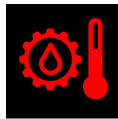
**Gearbox oil temperature** (blinks red)

Temperature of gearbox oil in the distribution gearbox is too high.

**Supply pressure oil filter** (blinks red)

Supply pressure oil filter does not work correctly.

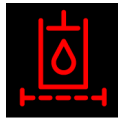
**Hydraulic oil filter** (blinks red)

Hydraulic oil filter does not work correctly.

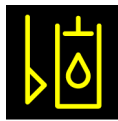
**Hydraulic oil fill level** (lit yellow)

Fill level of the hydraulic oil tank is low.

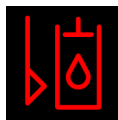
**Hydraulic oil fill level** (blinks red)

Fill level of hydraulic oil tank is too low.

**Hydraulic oil fill level** (lit yellow)

Fill level of the hydraulic oil tank is high.

**Coolant fill level** (lit yellow)

Coolant fill level is low.

**Coolant fill level** (blinks red)

Coolant fill level is too low.

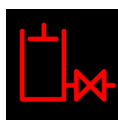
**Gate valve hydraulic oil tank** (blinks red)*Hydraulic oil tank* gate valve is closed.**Exhaust aftertreatment system** (lit yellow)

Fill level of urea tank is low or error in exhaust aftertreatment system.

3.19 Screen Access control



Access control

Switch to the *Access control* screen.

The *Access control* screen serves to manage and/or control access to the machine.

3.19.1 Without retrofit kit access control (black ignition keys)

This situation occurs under the following conditions:

- Machine was delivered with software without the *access control* screen.
- Machine was delivered with black ignition keys.
- Machine receives a retrospective software update and now features the *access control* screen.
- Retrofit kit access control was not purchased.

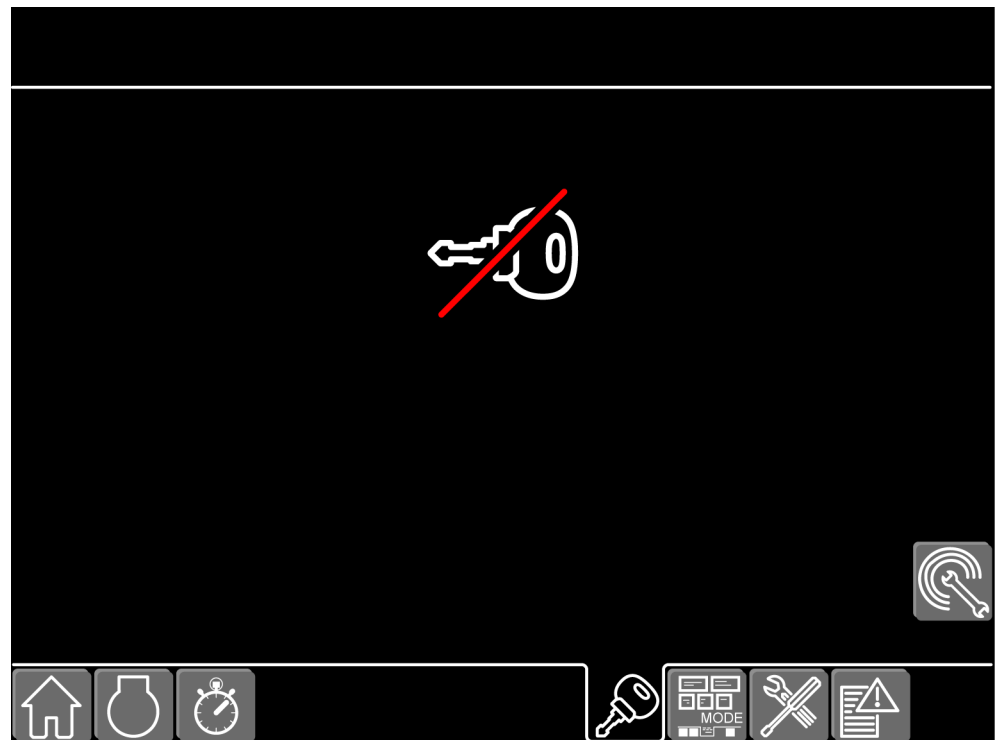

Fig. 696: Access control screen - without retrofit kit access control (black ignition keys)



Remote service

Switch on remote service.



Remote service (lit green)

Switch off remote service.

**Alphanumeric keypad** (lit red)

Serves to enter or delete values in the entry fields.

**Reset leader tilt**

By pressing button *Reset leader tilt*, the current digital tilt displays (x and y value) start to blink and the button *Confirm input* appears on the display field.

**Confirm input**

Pressing the button *Confirm input* resets the current tilt displays to zero. Press *Confirm input* button within three seconds. If reset was successful, digital and analog tilt values read zero.

**Saving the second automatic leader adjustment**

By pressing and holding button *Save second automatic leader adjustment* (for at least three seconds), the actual digital inclination values of the leader (x and y value) are saved in the second automatic leader adjustment.

**Display first automatic leader adjustment**

Column shows the x and y coordinates of the first automatic leader adjustment.

**Display field Feed winch rope measuring system***

The rope length on the feed winch since the last reset is displayed.

**Display field "Kelly winch rope measuring system"**

The rope length on the Kelly winch since the last reset is displayed.

**Kelly winch reeving**

The rope reeving on the Kelly winch is displayed.

Keyboard menu

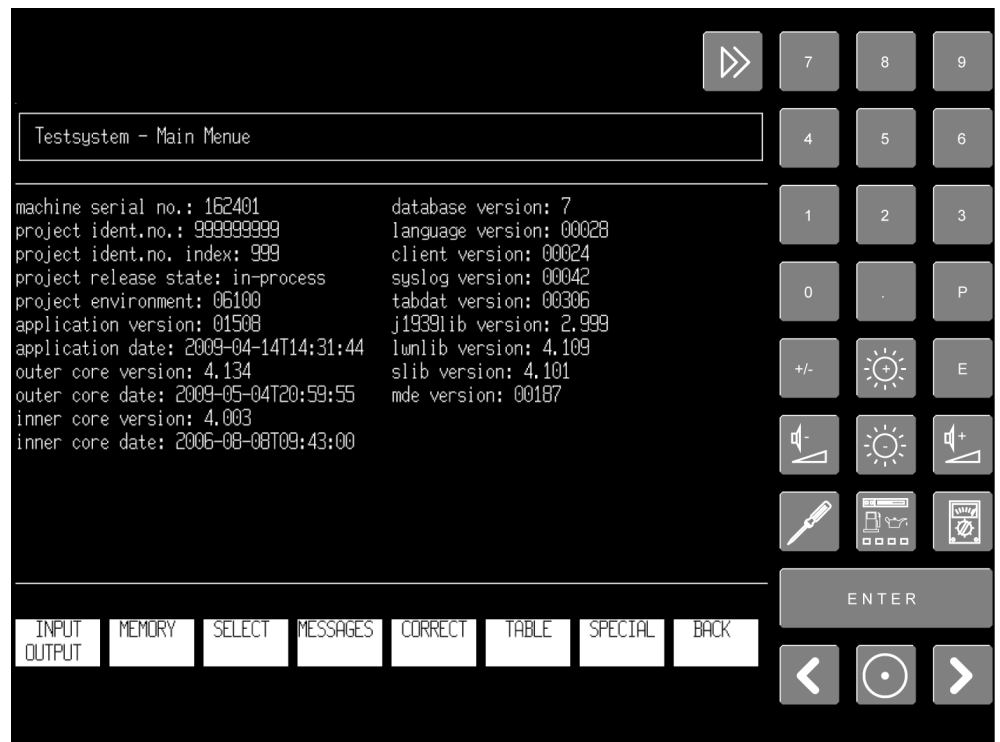
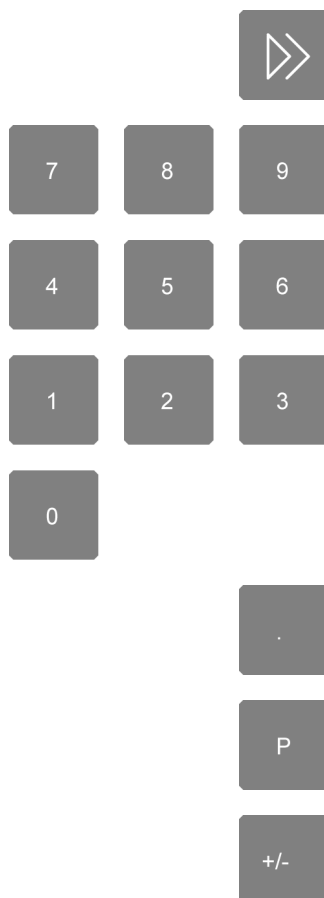

Fig. 822: Settings - Litronic testing system screen with keyboard menu



Minimize

Switch to menu bar ([For more information see: Menu bar, page 295](#)).

Numbers

Enter numbers.

Decimal point

Enter comma.

Powers

Select potencies.

Inverting numbers

Invert numbers.

Left linear control lever

Function assignment for movement directions on left linear control lever

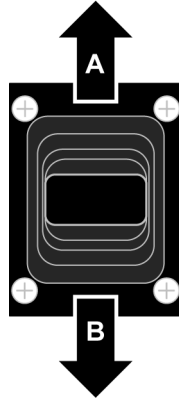

Fig. 890: Function assignment for movement directions on left linear control lever

Movement direction	Preselection rotary control knob	Pictogram	Function
A	1		Moving left crawler forward
	2		Increasing radius
B	1		Moving left crawler backward
	2		Decreasing radius

Tab. 70: Function assignment for movement directions on left linear control lever

The symbol *Radio remote control turned on* appears in the following situations:

- Turning on radio remote control
- Disconnection for more than 8 seconds
- Emergency stop

Monitor buttons



Fig. 976: Monitor buttons

- | | | | |
|---|------------------------------|---|---------------------------------------|
| 1 | Scrolling screen down | 4 | Opening/closing screen error messages |
| 2 | Scrolling screen up | 5 | Acknowledging message |
| 3 | Internal menu remote control | 6 | Acknowledging message |

4.2.1 Adjusting the control stand horizontally

Ensure that the following conditions are fulfilled:

- Safety lever is pulled up.

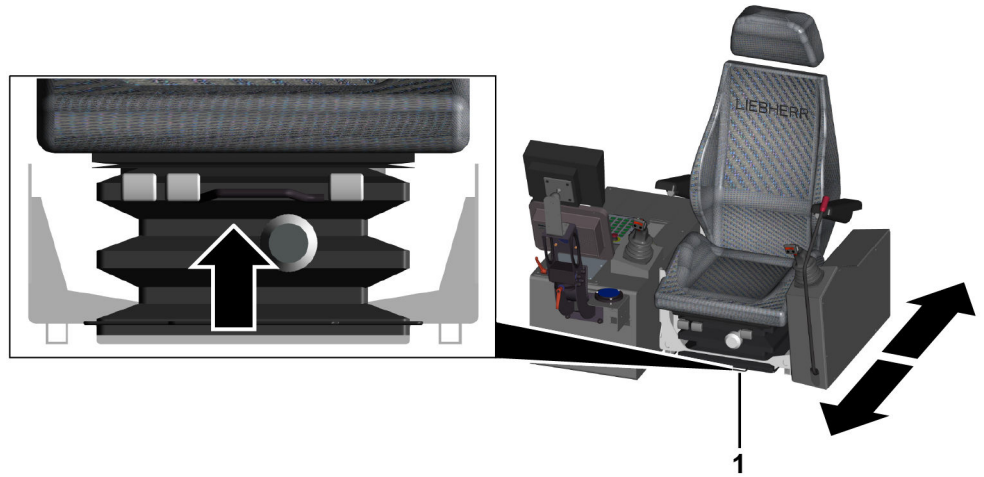

Fig. 985: Adjusting the control stand horizontally (illustration of principle)

1 Lever *Adjust control stand horizontally*

- ▶ Pull up and hold the lever *Adjust control stand horizontally* 1.
- ▶ Adjust control stand horizontally.
- ▶ Release the lever *Adjust control stand horizontally* 1.
 - ▷ Control stand engages automatically.

4.2.2 Adjusting the operator's seat

Ensure that the following conditions are fulfilled:

- Safety lever is pulled up.

4.4 Windscreen wiper system

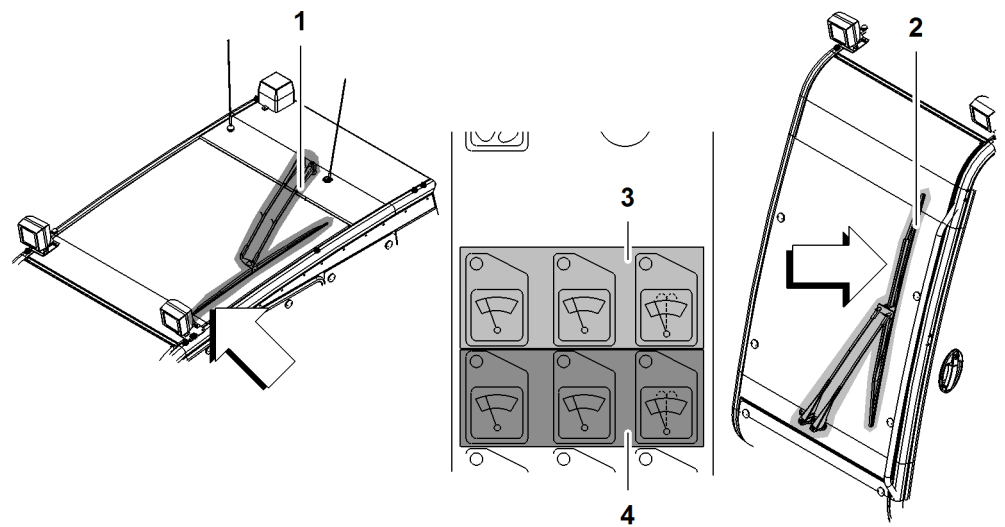
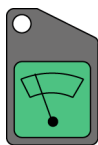

Fig. 999: Windscreen wiper system

- | | | | |
|---|-----------------------------------|---|--|
| 1 | Windscreen wiper for roof window | 3 | Operating elements on control panel X11 for front windscreen wiper |
| 2 | Windscreen wiper for front window | 4 | Operating elements on control panel X11 for roof windscreen wiper |

4.4.1 Operating the windscreen wipers

Activates/deactivates continuous mode of the windscreen wiper.



- ▶ Press the *Windscreen wiper* button on control panel X11.

▷ Continuous mode of windscreen wiper is activated.

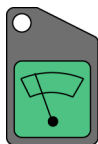

- ▶ Press the *Windscreen wiper* button on control panel X11 again.

▷ Continuous mode of windscreen wiper is deactivated.

Activates/deactivates interval mode of the windscreen wiper

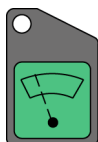

- ▶ Press the *Intermittent windscreen wiper* button on control panel X11.

4.6 Additional cab equipment

4.6.1 Using the horn

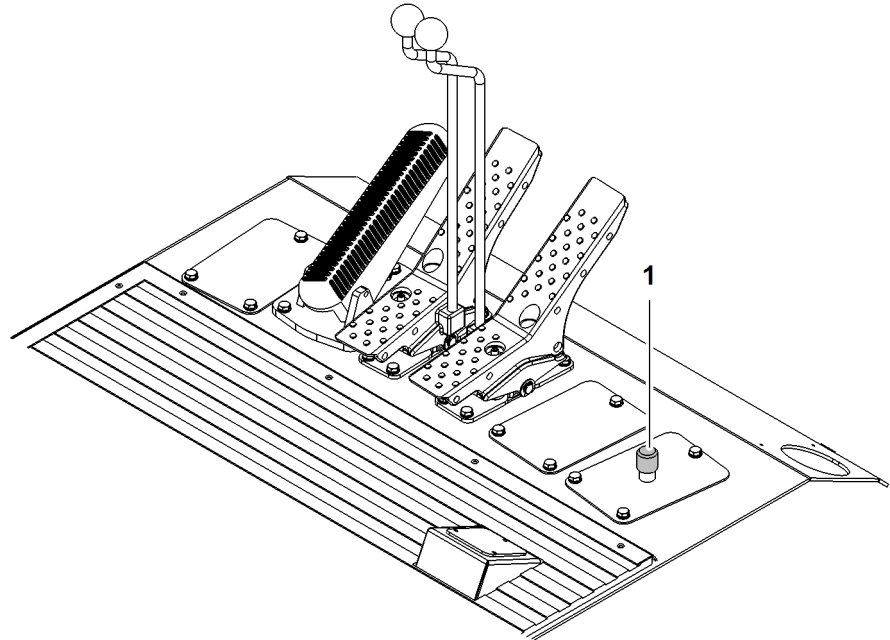

Fig. 1034: Foot switch for horn (illustration of principle)

1 Foot lever horn

- ▶ Press foot lever horn 1.
 - ▷ The horn sounds.

4.6.2 Operating the safety lever



WARNING

Drives may still be moving after having been switched off!

- ▶ Fold safety lever up only when drives have stopped.
-

Troubleshooting

Error message appears after several attempts?

- ▶ Contact Liebherr customer service.

4.11.4 Selecting mode**DANGER**

Improper operation of machine in the respective mode!
Toppling of machine.

- ▶ Make sure that there is sufficient knowledge about the application options, special characteristics and dangers of the respective mode.

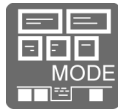

- ▶ Press the button *Mode* on the monitor.
 - ▷ *Mode* screen is displayed on the LCD monitor.



- ▶ Select required mode by pressing the corresponding button (here for example: button *CFA drilling* *).

- ▷ Background color of the *CFA drilling** button on the monitor turns black:

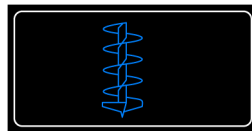

Fig. 1052: *CFA drilling** mode was pressed but not yet confirmed



- ▶ Keep the button *Confirming input* on control panel X12 pressed.



- ▶ Press the button *Confirming input* on the monitor.
- ▶ Release the button *Confirming input* on control panel X12.

- ▷ Symbol *Switch off ignition* is lit on the monitor:



Fig. 1055: Symbol *Switch off ignition*

- ▷ All functions of the machine are blocked.
- ▶ Switch off the ignition.
- ▶ Switch on ignition after approx. 10 seconds.
 - ▷ The desired mode has been selected.



Fig. 1056: *CFA drilling** mode confirmed



Fig. 1074: Symbol Radio remote control active

- ▷ Symbol *Preselect remote control mode* is displayed on radio remote control monitor:



Fig. 1075: Symbol Preselect remote control mode

- ▷ Remote control mode can be preselected with rotary switch. (For more information see: [3.25.1 Operating elements, page 304](#))

Turning the diesel engine on or off

Ensure that the following conditions are fulfilled:

- Connection between transmitter and receiver of the radio remote control is established.
- Symbol *Radio remote control locked* is hidden on the radio remote control monitor.

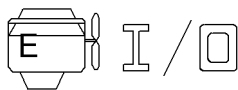

- ▶ Press the button *Diesel engine* on the radio remote control.
 - ▷ Diesel engine is turned on.
- ▶ Press button *Diesel engine* on radio remote control again.
 - ▷ The diesel engine is switched off.



Note

Turn off diesel engine with radio remote control:

- ▶ It is also possible to turn off the diesel engine if the control of the machine functions is on hold.

Taking/ceding control in cabin



- ▶ Press the *Take/cede control* button on control panel X23.

- ▷ Control of machine functions is suspended.
- ▷ All machine functions are stopped.
- ▷ Symbol *Radio remote control locked* is displayed on radio remote control monitor:



Fig. 1078: Symbol Radio remote control locked (blinks)

- ▷ Symbol *Radio remote control* inactive* blinks on cabin monitor:

4.14 Swing



WARNING

Persons or obstacles in the swing range!

- ▶ Ensure that there are no persons or obstacles in the swing range.
- ▶ Leave the danger zone.

4.14.1 Operating the swing



DANGER

Incorrect use of the swing!
Toppling of machine.

- ▶ Accelerate and brake the swing slowly.
- ▶ Exclusively turn uppercarriage with erected leader.
- ▶ Do not swing uppercarriage on slopes.

NOTICE

Incorrect use of the swing!
Damage to machine.

- ▶ Adjust leader in such a way that the leader base plate does not collide with the crawler side frame.
- ▶ Remove auxiliary rope, hose kit and equipment from the collision zone.

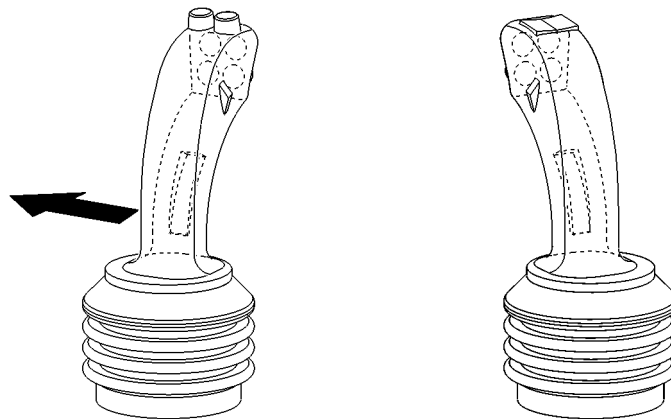

Fig. 1094: Operating the swing

- ▶ Move left control lever to left.
 - ▷ Uppercarriage swings to the left (counter-clockwise).
 - ▷ Warning signal sounds.
- ▶ Move left control lever to the right.
 - ▷ Uppercarriage swings to the right (clockwise).
 - ▷ Warning signal sounds.

4.14.2 Setting the swing speed

The machine has no safety devices to limit the swing speed.

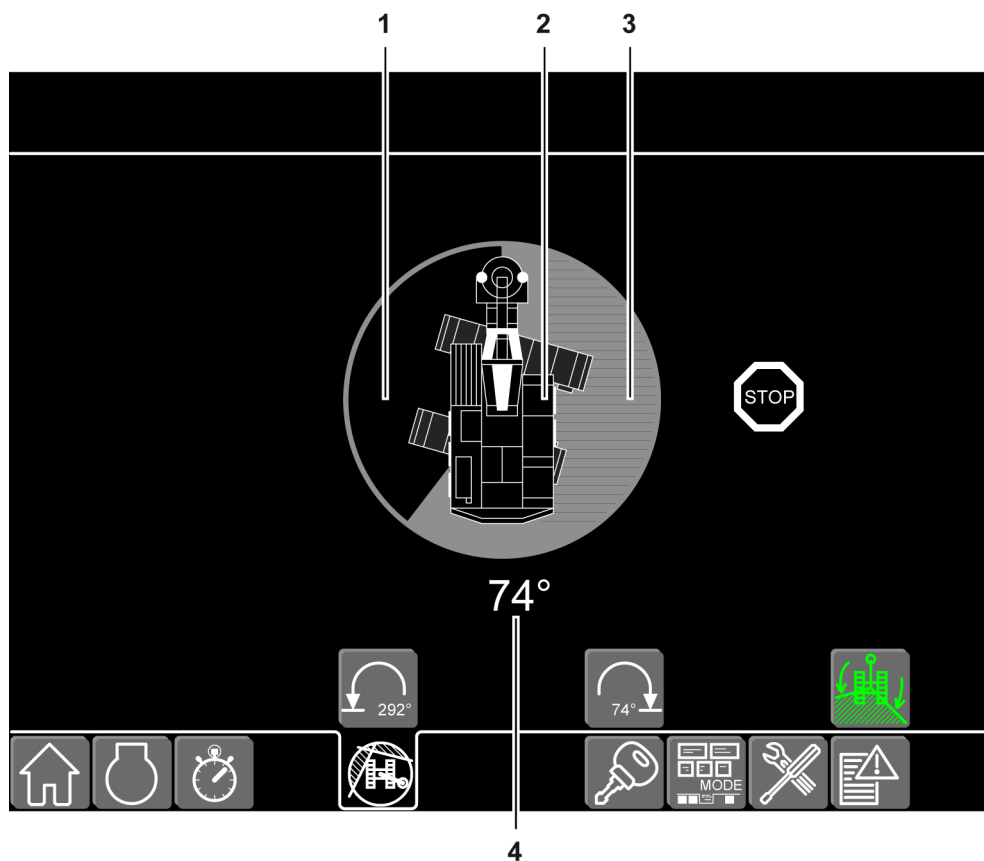

Fig. 1111: Uppercarriage moved to right swing limitation and stopped

- | | | | |
|---|---------------|---|---|
| 1 | Working range | 3 | Limited swing range |
| 2 | Uppercarriage | 4 | Current relative slewing angle 74°
(between uppercarriage and undercarriage) |



► Press the button *Deactivate swing limitation*.

▷ Swing limitation is deactivated:

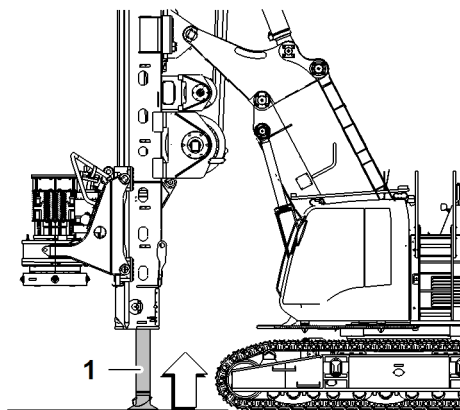
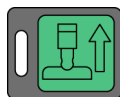

Fig. 1131: Leader support retracts (illustration of principle)

1 Leader support

Retracting the leader support with control panel X25



► Press the button *Retract leader support* on control panel X25.

- ▷ LED of the button *Retract leader support* is lit.
- ▷ Leader support retracts:

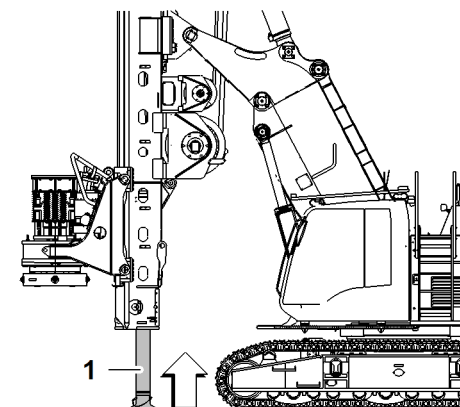

Fig. 1133: Leader support retracts (illustration of principle)

1 Leader support

CLICK HERE TO **DOWNLOAD** THE COMPLETE MANUAL

- Thank you very much for reading the preview of the manual.
- You can download the complete manual from: www.heydownloads.com by clicking the link below



- Please note: If there is no response to CLICKING the link, please download this PDF first and then click on it.

CLICK HERE TO **DOWNLOAD** THE COMPLETE MANUAL

Reeving the auxiliary winch

Reeving the auxiliary winch with control lever

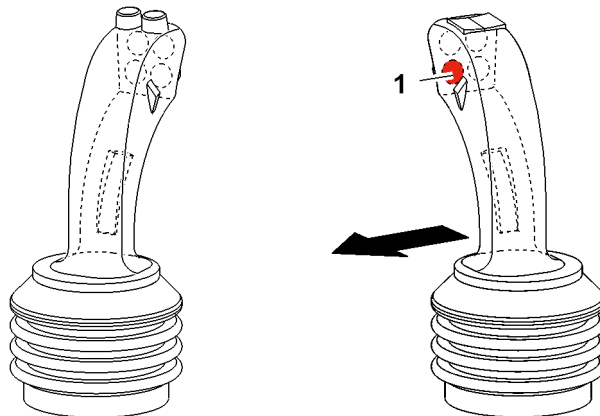

Fig. 1150: Reeving the auxiliary winch with control lever

- 1 Button *Toggle between rotary drive and auxiliary winch*
 - ▶ Press and hold the button *Toggle between rotary drive and auxiliary winch 1* on the right control lever.
 - ▷ LED of the button *Auxiliary winch* is lit.
 - ▶ Move right control lever to the left.
 - ▷ Auxiliary winch winds up.
 - ▷ As soon as hook triggers hoist limit switch: symbol *Auxiliary winch top limit switch* blinks in the status display on screen.



Fig. 1151: Symbol Auxiliary winch top limit switch

Reeving auxiliary winch with preselection on control panel X23

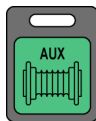

- ▶ Press the button *Auxiliary winch* on control panel X23.
 - ▷ LED of the button *Auxiliary winch* is lit.
- ▶ Move right control lever to the left.
 - ▷ Auxiliary winch winds up.
 - ▷ As soon as hook triggers hoist limit switch: symbol *Auxiliary winch top limit switch* blinks in the status display on screen.



Fig. 1153: Symbol Auxiliary winch top limit switch

- ▷ Kelly winch rope measuring system is set to zero.

4.21.2 Programming the rope measuring system

Exact display of the rope measuring system requires programming of rope reeving and layer change for the corresponding winch.

This is entered on the screen "Settings - components".

Programming the reeving



- ▶ Press the *Assembly mode* button on control panel X12.
 - ▷ Assembly mode is activated.



- ▶ Press the *Settings* button on the screen.



- ▶ Press the *Settings - components* button on the screen.

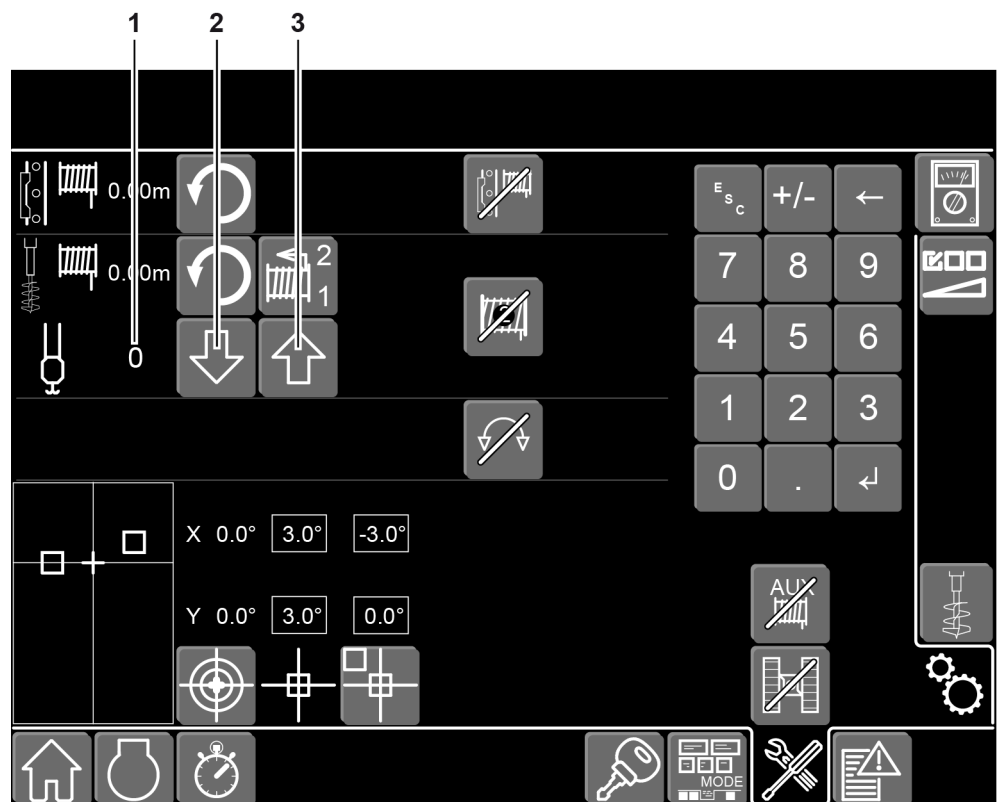

Fig. 1173: Screen "Settings - components"

- 1 Display "Kelly winch rope reeving"
 - 2 Kelly winch rope reeving - reduce value
 - 3 Kelly winch rope reeving - increase value
- ▶ Adjust the rope reeving value by pressing the button *Kelly winch rope reeving - reduce value 2* or the button *Kelly winch rope reeving - increase value 3*.

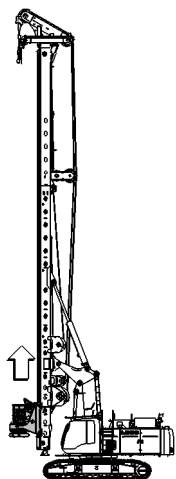

Fig. 1196: Universal carriage lifts in overdrive (illustration of principle)

Limiting the feed speed



Fig. 1197: Control unit Feed speed on control panel X25 (only for slow gear)

- | | | | |
|----------|---|----------|--------------|
| 1 | Rotary control knob <i>Feed speed</i> | 3 | Not assigned |
| 2 | Display <i>Feed speed</i> (LED is lit when rotary control knob is active) | | |

- ▶ Push the right control lever forwards or backwards.
- ▶ Turn the rotary control knob *Feed speed* **1** clockwise on control panel X25.
 - ▷ Feed speed increases.
- ▶ Turn the rotary control knob *Feed speed* **1** on control panel X25 counter-clockwise.
 - ▷ Feed speed decreases.

4.25.2 Saving drilling movement

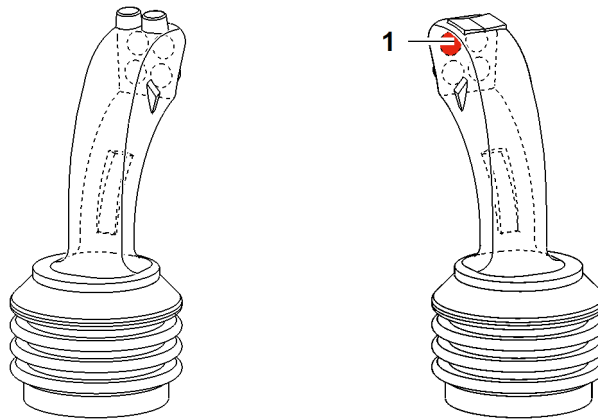

Fig. 1221: Saving drilling movement

1 Button Save drilling movement

- ▶ Adjust the right control lever (move to left/right).
- ▶ Press the button *Save movements 1*.
- ▶ Return control lever to zero position.
 - ▷ The symbol *Movement saved* appears on the status display on the LCD monitor.



Fig. 1222: Symbol Movement saved

- ▶ Move right control lever or press the button *Save movements* again 1:
 - ▷ Saved movement is deleted.

4.25.3 Switching on the load moment limiter*



- ▶ Press the *Settings* button.
 - ▷ LCD monitor switches to the "Settings" screen.



- ▶ Press the *Equipment settings* button.



- ▶ Press the button *Limit torque*.
 - ▷ Symbol *Limit torque* appears.
 - ▷ Torque limitation is activated.

4.25.4 Bypassing the torque limitation*

Ensure that the following conditions are fulfilled:

- Kelly winch not in free-wheel.

4.27 CFA drilling*

CFA drilling or continuous flight auger drilling is a method with which the pile is produced on site without pipe.

Procedure:

- Drilling in the auger down to the final depth. The soil is partially shifted.
- When drawing, the concrete is pressed in through the hollow auger. It is important to not draw too fast so that the borehole does not collapse and the pile is not interrupted. The optional concrete pressure display prevents this.
- Once the auger has been drawn, the reinforcement (reinforcement cage) is pressed or vibrated in.

The following is required for CFA drilling*:

- Auxiliary winch
- Feed system

NOTICE

Improper operation of rotary drive and equipment!
Severe injuries or damage to machine.

- ▶ Observe the operation manual of the respective manufacturer.
 - ▶ Carry out CFA drilling only when using falling object protection, concrete supply pipe, concrete quantity measurement, extraction device and auger cleaner.
-

4.27.1 Selecting CFA drilling



- ▶ Select the screen *Operation - CFA drilling* .

- ▷ Screen *Operation - CFA drilling* is displayed.

4.28.4 Switching torque of rotary drive1

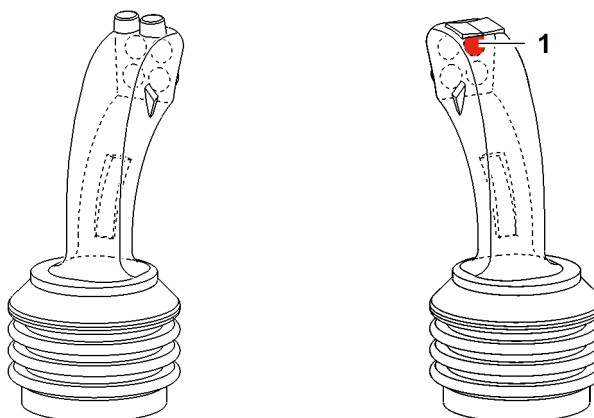

Fig. 1279: Switching torque of rotary drive 1

1 Button Torque rotary drive 1

- ▶ Press the button *Torque rotary drive 1* 1 on the right control lever.
- ▷ *Overdrive* symbol appears on monitor.



Fig. 1280: Symbol overdrive

4.28.5 Actuate rotary drive2 (pipe)

Turning rotary drive2 to the right

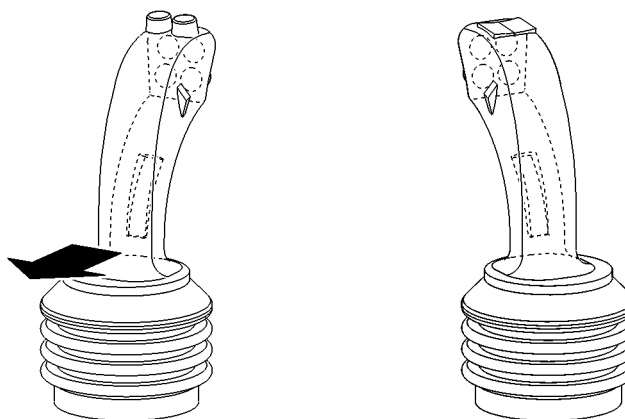

Fig. 1281: Turning rotary drive2 to the right

- ▶ Move left control lever backward.
- ▷ Rotary drive turns right.

4.30 Soil mixing*

With soil mixing, binders and soil are mixed on site. The pore cavities in the soil are filled with binder suspension in the process. The result is a compacted soil defined on the basis of auger geometry. One, two or three rotary drives or augers can be used.

Procedure:

Drilling in the auger(s) to the final depth. During finishing and pulling the auger, the present soil is mixed up and entered into the binder suspension through the hollow core pipe.

Drilling pressure and torque are displayed separately for each rotary drive.

The following is required for soil mixing*:

- Auxiliary winch
- Feed system

NOTICE

Improper handling of rotary drive and tool and/or equipment!

- ▶ Observe the operation manual of the respective manufacturer.
-

NOTICE

Improper operation of tool and/or equipment!

Damage to tool and/or equipment.

- ▶ Make sure that tool and/or equipment are adapted to the power of the rotary drive.
 - ▶ Observe drilling torque.
 - ▶ If necessary, operate tool and/or equipment with torque limitation.
-

4.30.1 Preselecting soil mixing

- ▶ Set *soil mixing* mode .
 - ▷ Operation - Soil mixing screen is displayed:

**Note**

As of a set delivery rate of 600 l/min (158.5 gal/min):

- ▶ Set pump number to 2.



- ▶ Press *Enter* button.
 - ▷ Value is applied by the control.

**Note**

In case of wrong entry:

- ▶ Old value is preserved.

4.31.3 Activating the casing oscillator - standard mode



- ▶ Press button *Casing oscillator on/off* on control panel X23 and hold for at least two seconds.

- ▷ Button *Casing oscillator on/off* is lit.
- ▷ The screen *Kelly drilling with casing oscillator* appears:

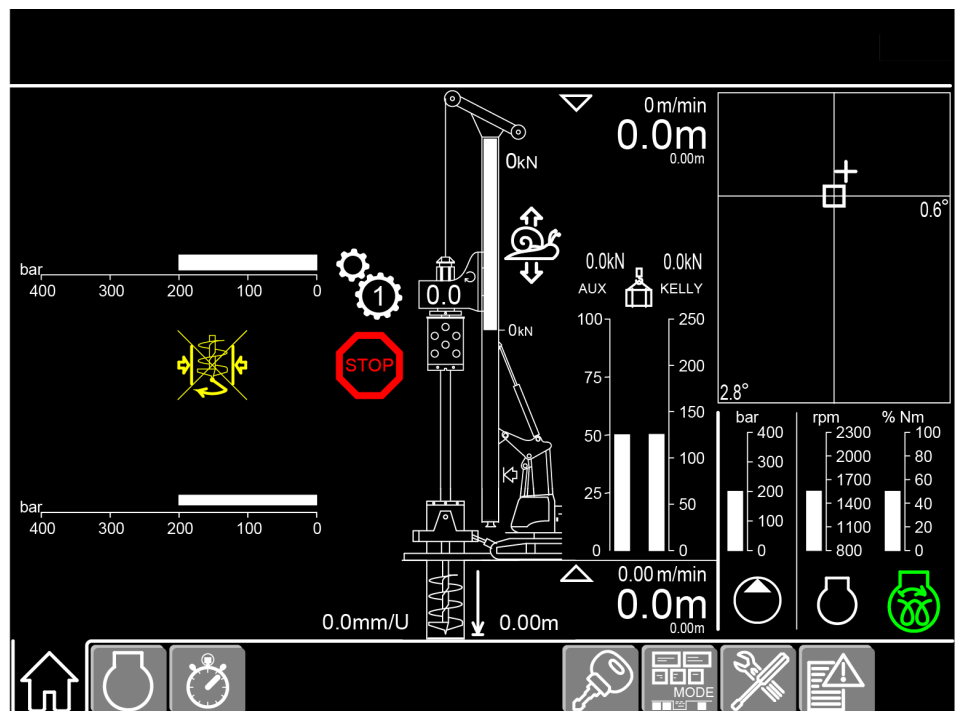

Fig. 1335: Screen Kelly drilling with casing oscillator

4.31.4 Activating the casing oscillator - ecological mode



- ▶ Press button *Casing oscillator on/off* on control panel X23.

- ▷ Button *Casing oscillator on/off* blinks.



- ▶ Enter nominal value.



Correcting the value:

- ▶ Press the *Cursor back* button.
 - ▷ Value can be corrected.



- ▶ Press the *Enter* button.
 - ▷ Value is applied by the control.



Note

In case of wrong entry:

- ▶ Old value is preserved.

4.33.3 Turning the rotary drive

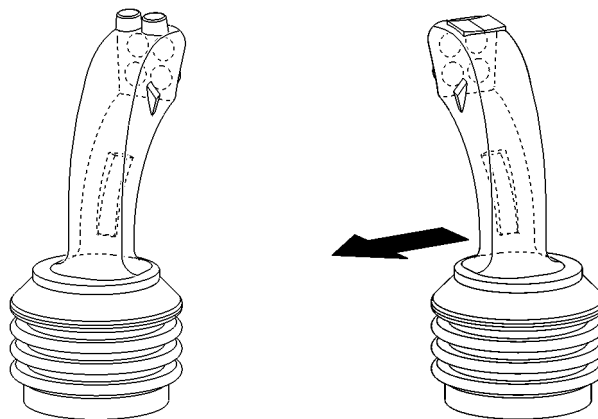

Fig. 1358: Turning the rotary drive to the right

- ▶ Move right control lever to the left.
 - ▷ Rotary drive turns right.

4.37.2 Long interruption of work

Ensure that the following conditions are fulfilled:

- Machine does not impede traffic.
 - Machine storage site is adequately secured.
 - External energy supply for the safety equipment is secured (e.g. helicopter warning light).
- ▶ Place leader vertical.
 - ▶ Set down all loads and secure.
 - ▶ Suspend empty hook in hook fixing point.
 - ▶ Fold up safety lever.
 - ▶ Turn ignition key to position **0**.
 - ▷ Diesel engine is turned off.
 - ▷ Litronic control system is switched off.

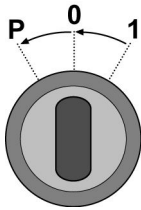

- ▶ Switch off the auxiliary heating, or program it correctly.
- ▶ Remove ignition key and keep in a safe place.

Switching off battery main switch:

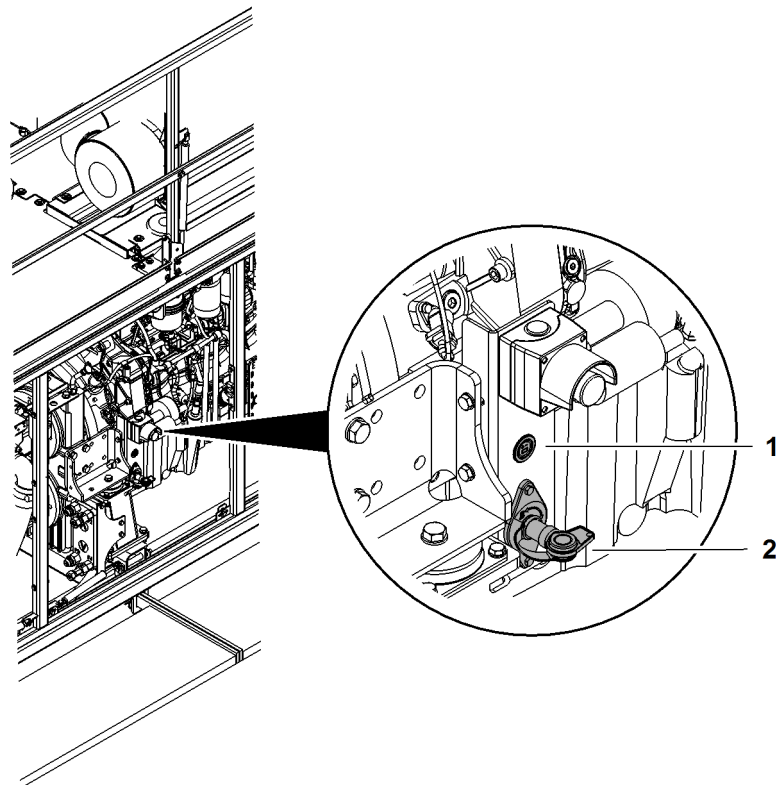

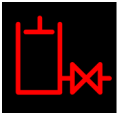





Fig. 1374: Turning off the main battery switch (illustration of principle)

1 Warning light

2 Main battery switch

Symbol/status	Cause	Remedy
 lit yellow	Fill level of the hydraulic oil tank is too low.	Fill in hydraulic oil.
 lit yellow	Fill level of the hydraulic oil tank is too high.	Drain hydraulic oil.
 blinks red	Gate valve <i>hydraulic oil tank</i> is closed.	Make sure there is no danger. Open the gate valve of the <i>hydraulic oil tank</i> .
 lit yellow	Leak in the hydraulic oil circuit.	Contact Liebherr customer service.
 blinks red	Fuel pressure is too high.	Contact Liebherr customer service.
 blinks red	Fuel temperature is too high.	Contact Liebherr customer service.
 blinks red	Water in the fuel filter.	Drain water in the condensation trap.
 blinks red	Charge air filter does not work correctly.	Contact Liebherr customer service.

Tab. 78: Error displays

5.1.3 Troubleshooting

Rectifying grave engine error message

The cause of the error appears either on the *Engine* screen or on the *Error messages* screen.

Description of the buttons:

- *PREVIOUS* and *NEXT* move between the interfaces.
- *BACK* returns to the *SPECIAL FUNCTIONS* screen.

5.2.3 Starting the Litronic® testing system



WARNING

No error messages from the Litronic control system may be displayed in the Litronic® testing system!

- ▶ Only work with the machine on the screen of the respective operating mode.
-



- ▶ Press the *Litronic testing system* button on the monitor.
 - ▷ The Litronic testing system main screen is displayed on the monitor.

- Minimum leader radius.
- Leader is always vertical.
- Rotary drive and drilling tool are lowered all the way.
- Drilling tool is completely emptied.

Traveling on gradients



DANGER

Incorrect traveling on gradients!
Toppling of machine.

- ▶ Only travel on gradients with erected leader.
 - ▶ Take great care with every travel movement of the machine.
 - ▶ Avoid dynamic travel movements.
-

Make sure that:

- The inclination value was measured by authorized service personnel and communicated to the machine operator before the machine is moved.
- That the drilling tool is without drilling equipment.
- Drilling tool is lowered.
- Gradient in traveling direction is at most **10° (17.6%)**.
- Lateral gradients are no more than **5° (8.7%)**.
- Leader is always positioned on hill side.
- Leader is always vertical.



DANGER

Incorrect driving of machine over undulations!
Toppling of machine.

- ▶ Do not travel on terrain edges.
 - ▶ Only travel on undulations with large radiuses.
 - ▶ When traveling over undulations, the entire crawler must be on the ground.
 - ▶ Make sure that the leader is permanently adjusted to vertical position.
-

NOTICE

Improper connection/disconnection of hydraulic lines!
Damage to machine.

- ▶ Observe hydraulic diagrams in the volume "Technical information".
 - ▶ Ensure that connections are clean and intact.
 - ▶ Ensure that disconnected connections are closed well and not leaking.
-

**WARNING**

Inadmissible stay on platform of rotary drive!
Fall from platform.

- ▶ Make sure persons only stay on the platform when the universal carriage and the rotary drive stand still.
 - ▶ Make sure that only one person is located on the platform.
-

**WARNING**

Insufficient visual contact between machine operator and person on platform of rotary drive!
Fall from platform.

- ▶ Make sure that person on the platform is always within machine operator's field of vision.
-

Moving platforms on uppercarriage* into working position

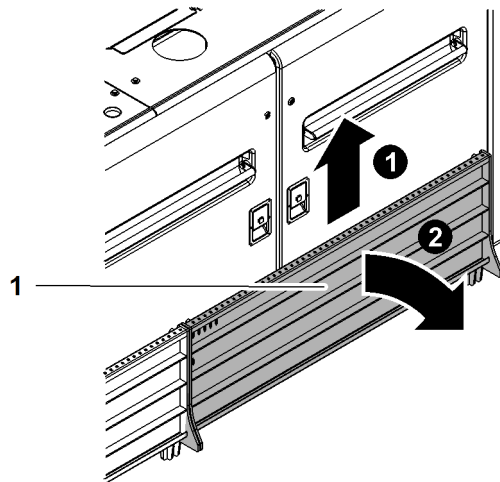

Fig. 1431: Moving platforms on uppercarriage into working position

1 Platform (5x)

► Pull platforms 1 up and fold down.

▷ Platforms on uppercarriage are in working position:

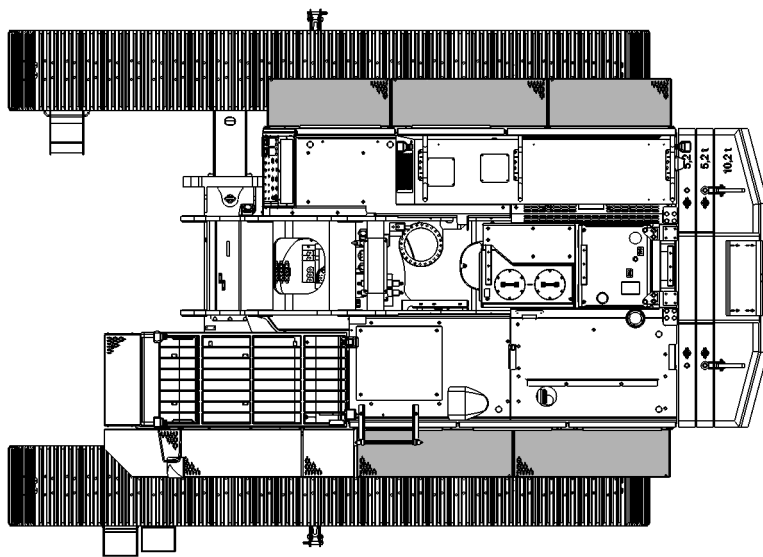

Fig. 1432: Platforms on uppercarriage are in working position

Make sure the following prerequisites are met:

- Machine is equipped with jacks for self-assembly.
- Pre-start checks have been carried out.
- Fitters were instructed and all safety measures are observed.
- "Installation and deinstallation regulations" are observed. (For more information see: [7.1 Work instructions for assembly/disassembly, page 535](#))
- Counterweight is not installed.
- Leader is placed on uppercarriage.
- Top part of leader is in working position (not folded in).
- Rotary drive is deinstalled.
- Cabin platforms are in working position.
- Assembly mode is activated.
- Cylinder adjustment functions are activated.
- Assist crane with sufficient load-bearing capacity is available.
- Sufficient space is available to turn the machine by 90°.
- Uppercarriage lock is removed.

Placing support pads underneath



DANGER

Incorrect use of support pads!
Toppling of machine.

- ▶ Use support pads attached on undercarriage.
- ▶ Make sure that support pads do not protrude into the transport vehicle's track.

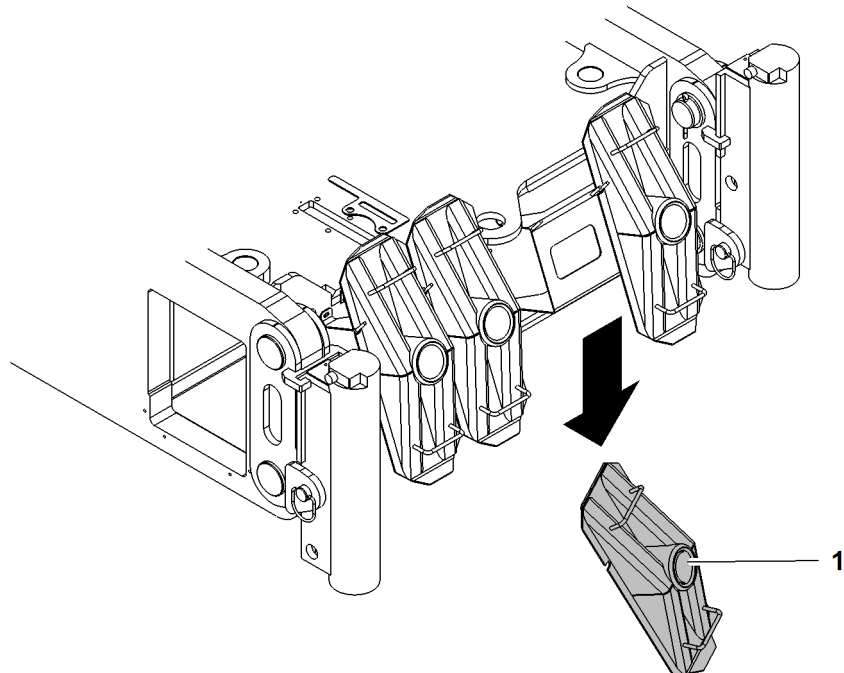

Fig. 1444: Placing support pads underneath

1 Support pad (4x)

- ▶ Remove support pads **1** from bracket.
- ▶ Place support pads **1** flat on the ground or on bedding layers.

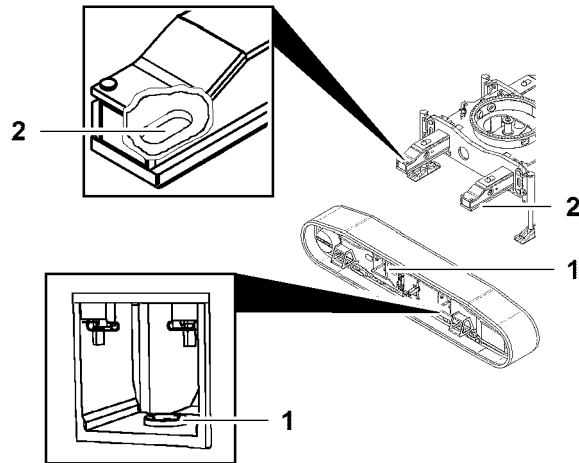

Fig. 1457: Pulling on the crawler side frame

1 Pin

2 Support opening



CAUTION

Improper rigging of crawler side frame!
Damage to machine.

► Rig crawler side frame slowly, step by step and evenly.

► Thread in pin 1 of the beam guides into support opening 2 on the bottom of the beams.

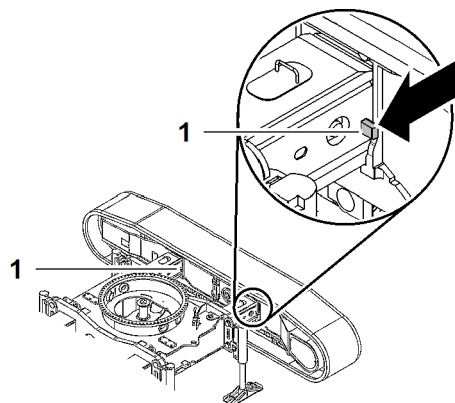

Fig. 1458: Sliding the crawler side frame supports onto beams

1 Rigging

Ensure that both assistants are available for alignment on the ends of the crawler side frame.

► Slide crawler side frame onto beams up to the stops 1.

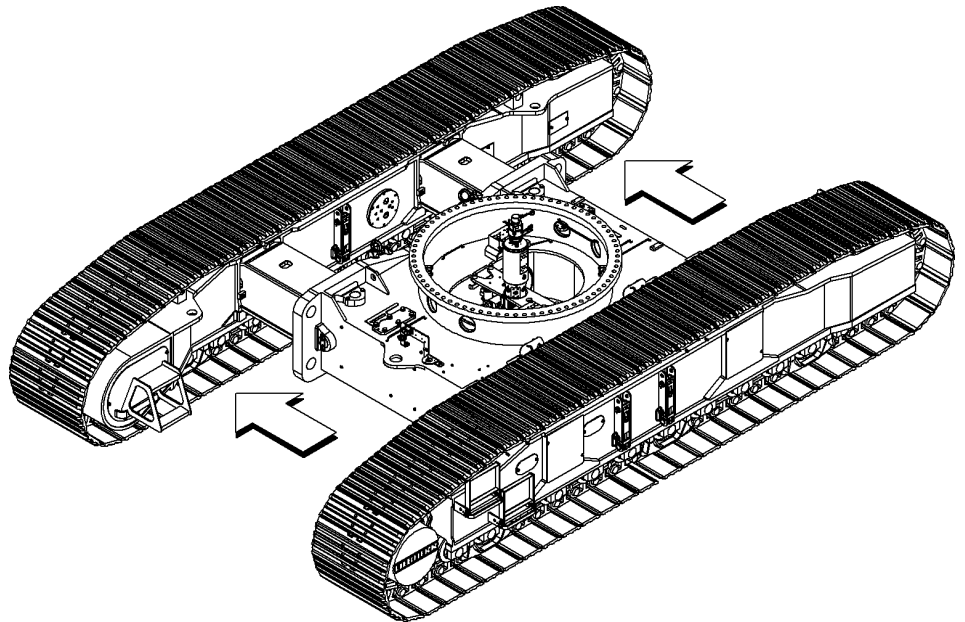

Fig. 1470: Left crawler side frame is extended

When crawler side frame is on outer pin connection points:

- ▶ Set control levers **1** for front track width adjustment and control lever **2** for rear track adjustment to neutral position.

Deinstalling the links between leader top and top part of leader

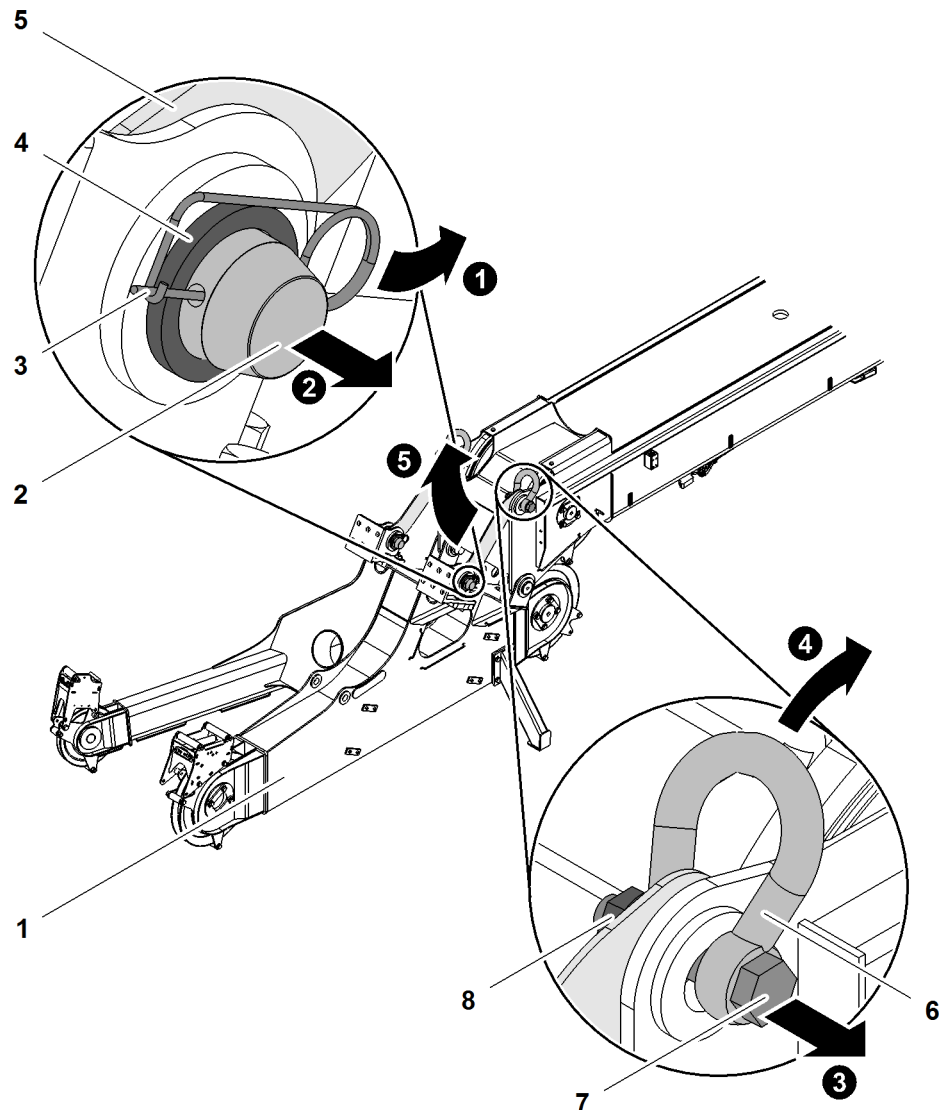

Fig. 1480: Deinstalling links

- | | | | |
|---|---------------------|---|--------------|
| 1 | Leader top | 5 | Link (2x) |
| 2 | Pin (2x) | 6 | Shackle (2x) |
| 3 | Locking spring (2x) | 7 | Screw (2x) |
| 4 | Washer (2x) | 8 | Nut (2x) |

- ▶ Remove pin 2, positioning disk 4 and locking spring 3.
- ▶ Remove shackle 6, screw 7 and nut 8.
- ▶ Remove link 5.
- ▶ Repeat procedure on opposite side.

Pulling in ropes

- ▶ Pull in Kelly and auxiliary rope.

- ▷ Pin connection cylinder retracts.

Undoing the rope lock

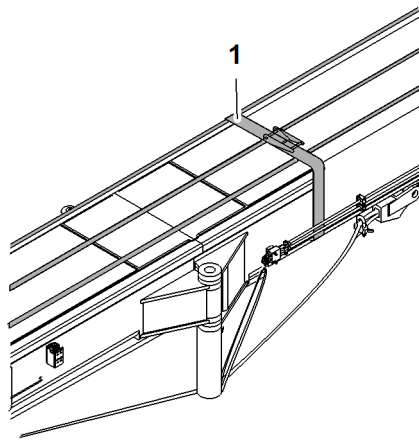

Fig. 1497: Undoing the rope lock (illustration of principle)

- ▶ Undo rope lock.

Placing the leader top into working position



WARNING

Movable, very heavy part!
Risk of crushing of limbs.

- ▶ Make sure that no persons are located between the top part of leader and the leader top.
- ▶ Make sure that no body parts are located between the ropes and components.

- Assembly mode is activated.
- Limit switches are not bypassed.

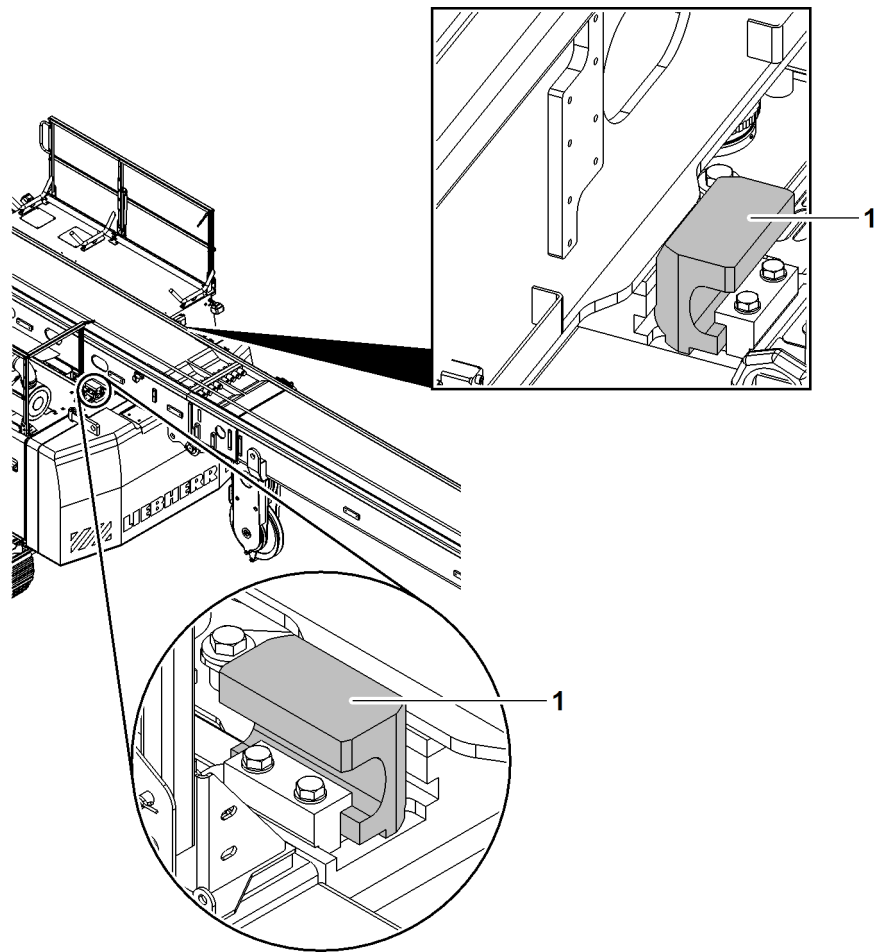

Fig. 1512: Leader claws

1 Leader claws



CAUTION

Improper assembly of the leader claws!
Damage to drilling rig.

- ▶ Make sure that the leader claws 1 on the left and right of the uppercarriage are mounted outwards.
-

7.4 Installing and connecting rotary drive



DANGER

Inadmissible use of lifting gear, rigging equipment and/or sling gear!
Load breakaway.

- ▶ Only use lifting gear, rigging equipment and sling gear admissible for the application in proper state.
- ▶ When selecting the sling gear (e.g. shackles, round slings) make sure that these do not damage each other or other components.
- ▶ When lifting loads with rigging equipment with more than two strands, make sure that the load is distributed evenly to all strands.
- ▶ Move assist crane slowly.



WARNING

Inadmissible stay on platform of rotary drive!
Fall from platform.

- ▶ Make sure persons only stay on the platform when the universal carriage and the rotary drive stand still.
- ▶ Make sure that only one person is located on the platform.



WARNING

Insufficient visual contact between machine operator and person on the platform of the rotary drive!
Fall from platform.

- ▶ Make sure that person on the platform is always within the machine operator's field of vision.

7.4.1 Installing rotary drive



CAUTION

Negligent mounting of rotary drive!
Crushing of limbs.

- ▶ Observe possible crushing and pinching risks during assembly.



WARNING

Improper positioning of rotary drive!
Bodily injuries (crushing).

- ▶ Secure equipment parts against sliding and toppling.

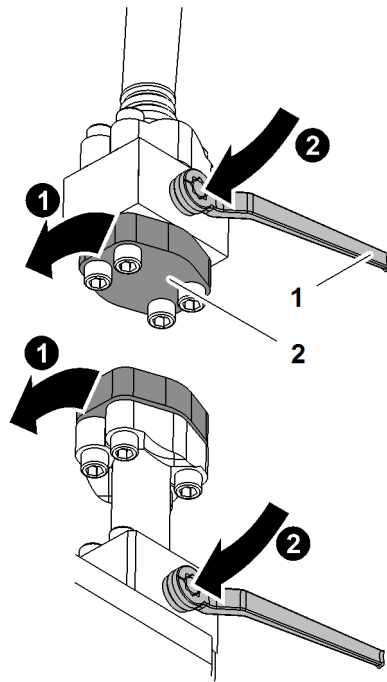

Fig. 1535: Dismantling the dummy flanges of the hydraulic lines

1 Lever (2x)

2 Dummy flange (2x)

► Dismantle dummy flanges 2.

► Install lever 1.

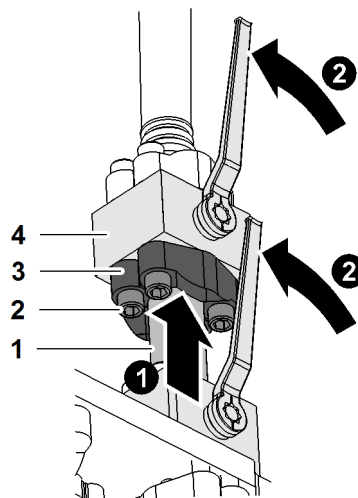

Fig. 1536: Connecting the hydraulic line

1 Connecting piece

3 Half shell (2x)

2 Screw (4x)

4 Ball tap (2x)

► Install connecting piece 1 with half shells 3 and screws 2 to ball tap 4.

► Open ball taps 4.

► Repeat procedure with all hydraulic lines.

► Connect multi-coupling.

Mounting the drilling tool

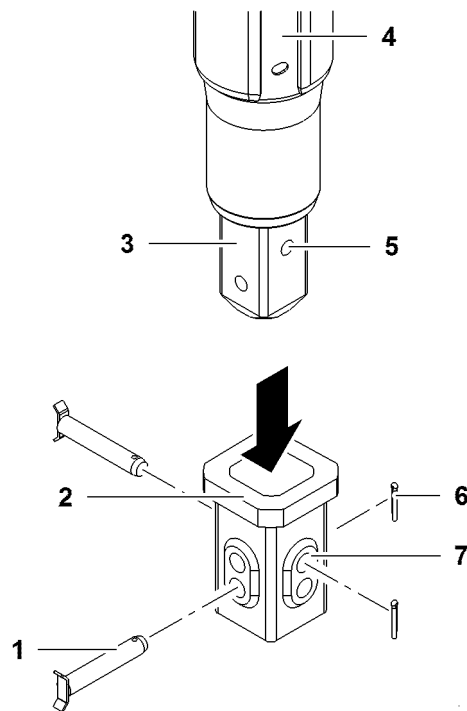

Fig. 1561: Mounting the drilling tool

- | | | | |
|---|-------------------------|---|-----------------------------|
| 1 | Pin (2x) | 5 | Square Kelly drillings (2x) |
| 2 | Kelly box drilling tool | 6 | Split pin (2x) |
| 3 | Square Kelly | 7 | Kelly box drillings (4x) |
| 4 | Kelly bar | | |

- ▶ Position drilling tool secured against toppling.
- ▶ Retract square Kelly 3 in Kelly box 2 drilling tool until square Kelly drillings 5 are aligned with Kelly box drillings 7.



DANGER

Improper installation of drilling tool!
Loosen drilling tool.

- ▶ Make sure that both pins 1 are installed and secured.
- ▶ Install pins 1 and secure with split pins 6.

Installing the shackle

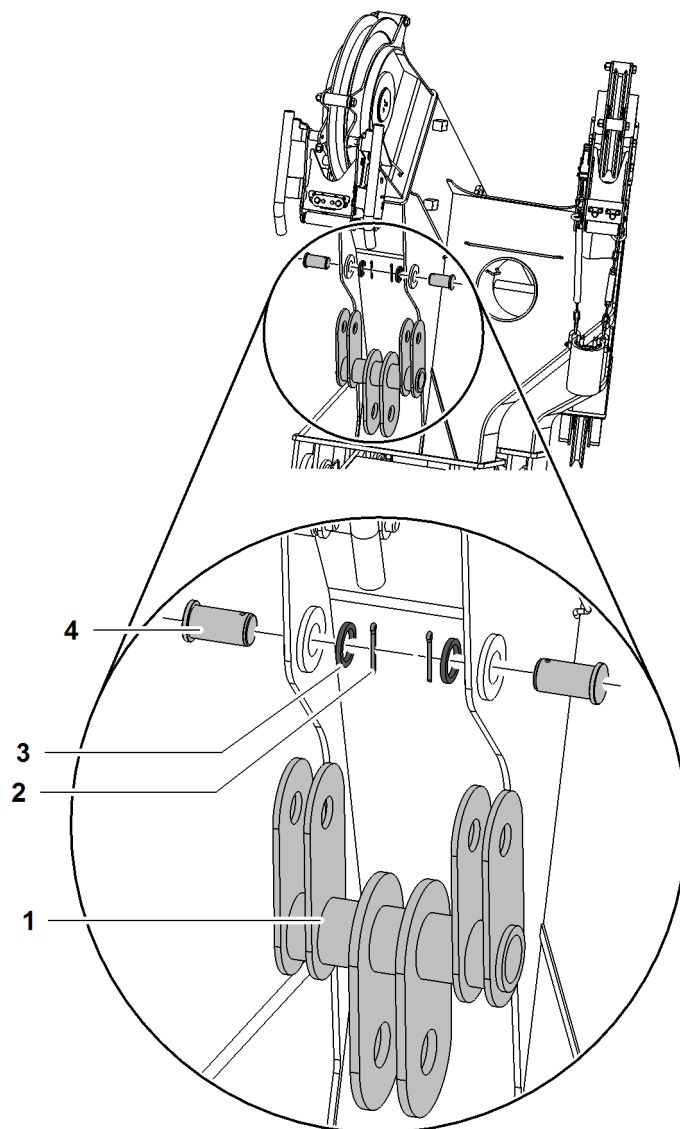

Fig. 1570: Installing the shackle

- | | | | |
|---|----------------|---|-------------|
| 1 | Shackle | 3 | Washer (2x) |
| 2 | Split pin (2x) | 4 | Pin (2x) |

- ▶ Position shackle 1.
- ▶ Insert pin 4.
- ▶ Secure pin 4 with washer 3 and split pin 2.
- ▶ Repeat procedure on opposite side.

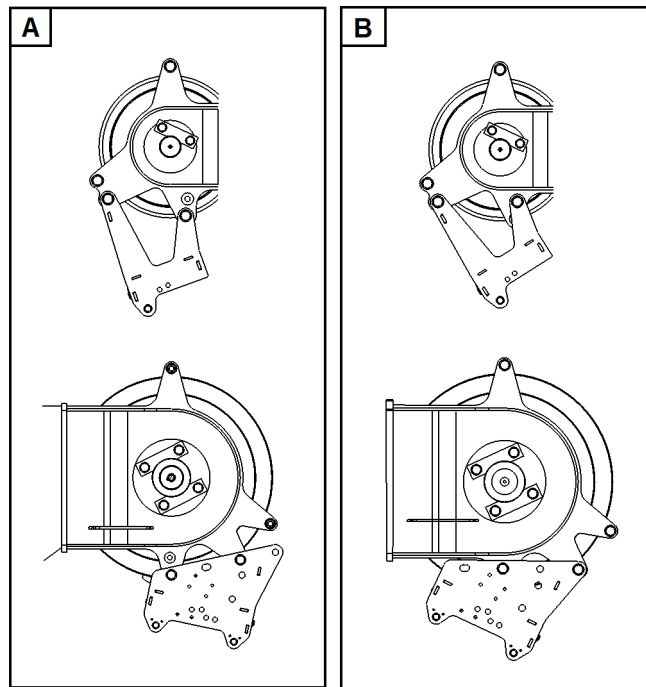

Fig. 1582: Fairlead position

A Standard fairlead position

B Pulling system fairlead position

NOTICE

Inadmissible operation with pulling system fairlead position **B** after deinstallation of pulling system!
Damage to ropes and fairleads.

► Make sure that fairleads are in standard position **A**.

► Set fairleads to standard position **A**.

7.6.2 Mounting the Kelly equipment*



DANGER

Unsecured ascent!
Danger of falling.

- Use suitable ascension aids.
- Ensure sufficient protection.



DANGER

Inadmissible use of lifting gear, rigging equipment and/or sling gear!
Load breakaway.

- Only use lifting gear, rigging equipment and sling gear admissible for the application in proper state.
- When selecting the sling gear (e.g. shackles, round slings) make sure that these do not damage each other or other components.
- When lifting loads with rigging equipment with more than two strands, make sure that the load is distributed evenly to all strands.
- Move assist crane slowly.

Installing the Kelly extension on the torque support

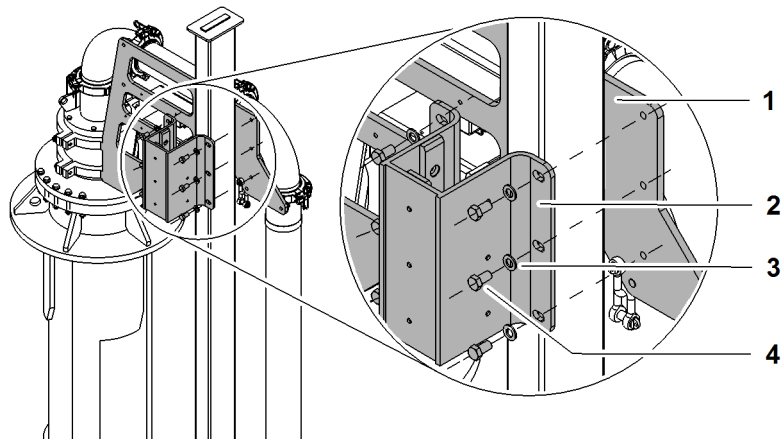

Fig. 1596: Installing the Kelly extension on the torque support

- | | | | |
|---|-------------------|---|-----------------------|
| 1 | Tremie head plate | 3 | Positioning disk (6x) |
| 2 | Slide plate | 4 | Screw (6x) |

- ▶ Position slide plate 2 on tremie head plate 1.
- ▶ Install positioning disks 3 and screws 4.

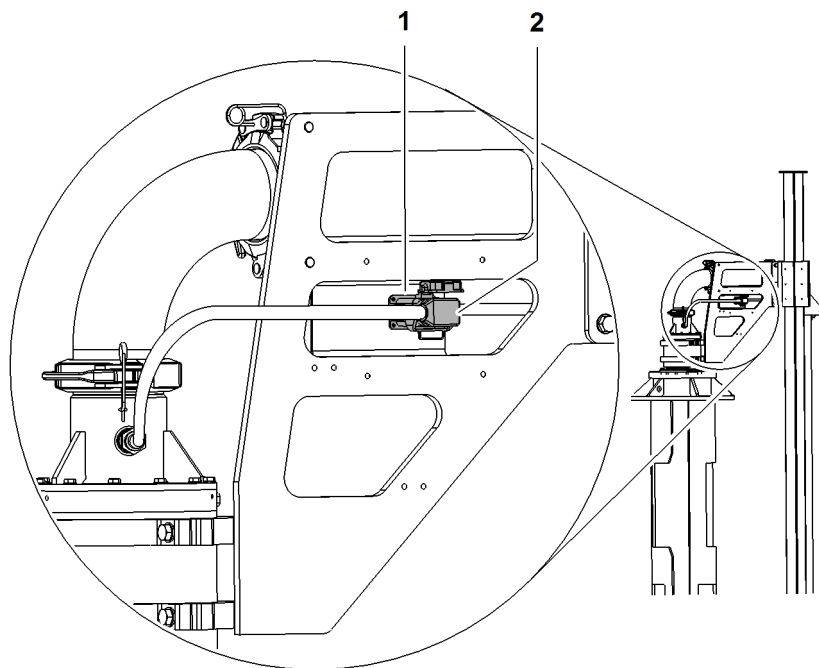

Fig. 1597: Connect concrete pressure sensor to extension cable

- | | | | |
|---|------------------------|---|-------------------------------|
| 1 | Socket extension cable | 2 | Concrete pressure sensor plug |
|---|------------------------|---|-------------------------------|

- ▶ Connect Concrete pressure sensor plug 2 to extension cable socket 1.

- ▶ Remove lifting cap.
- ▶ Retract Kelly extension base **2** in full displacer extension **1**.
- ▶ Install full displacer extension **1** on Kelly extension base **2**.

Installing displacer

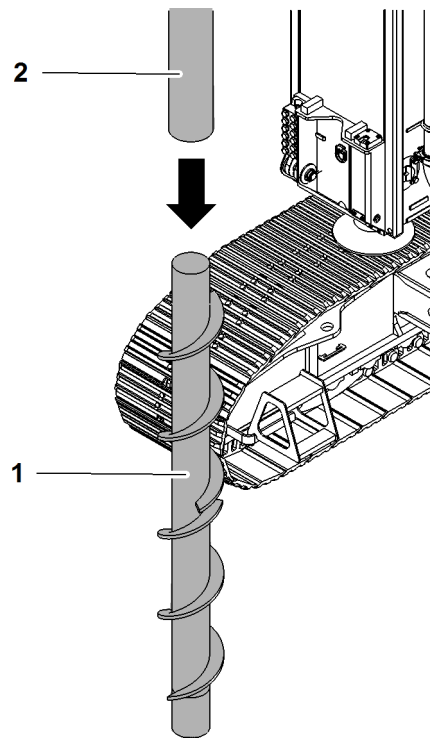

Fig. 1609: Positioning displacer (illustration of principle)

- | | | | |
|---|-----------|---|--------------------------|
| 1 | Displacer | 2 | Full displacer extension |
|---|-----------|---|--------------------------|
- ▶ Position displacer **1** underneath full displacer extension **2**.
 - ▶ Secure displacer **1** against toppling.
 - ▶ Retract full displacer extension **2** into displacer **1**.
 - ▶ Install displacer **1** on full displacer extension **2**.

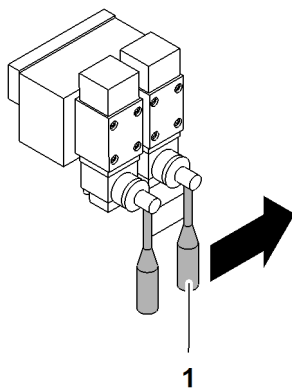

Fig. 1622: Folding top part of leader

1 Control lever Top part of leader

- ▶ Actuate top part of leader control lever 1.
- ▷ Top part of leader folds:

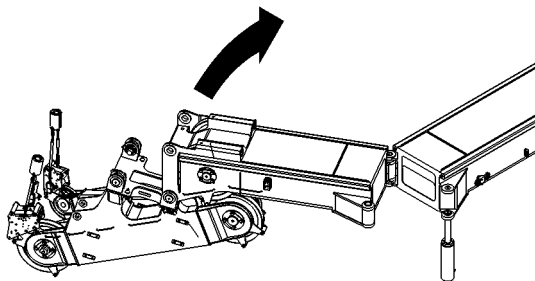

Fig. 1623: Top part of leader folds

- ▷ Top part of leader is fully folded:

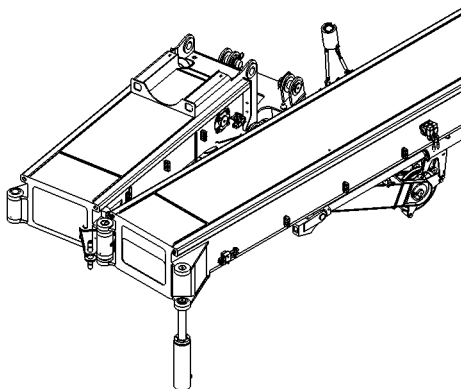

Fig. 1624: Top part of leader is fully folded

- ▶ Lash hose kit on leader.

If the machine does not have a self-loading system*:

- ▶ Converge track width adjustment.
- ▶ Load machine with self-loading system* in reverse order as unloading machine with self-loading system* (For more information see: [Unloading machine with self-loading system, page 556](#)).



Note

In the case of a machine with self-loading system*:

- ▶ Position machine so that there is sufficient space for accessing the transport vehicle.
- ▶ Note that the uppercarriage lock can be installed after turning the uppercarriage by 90°.

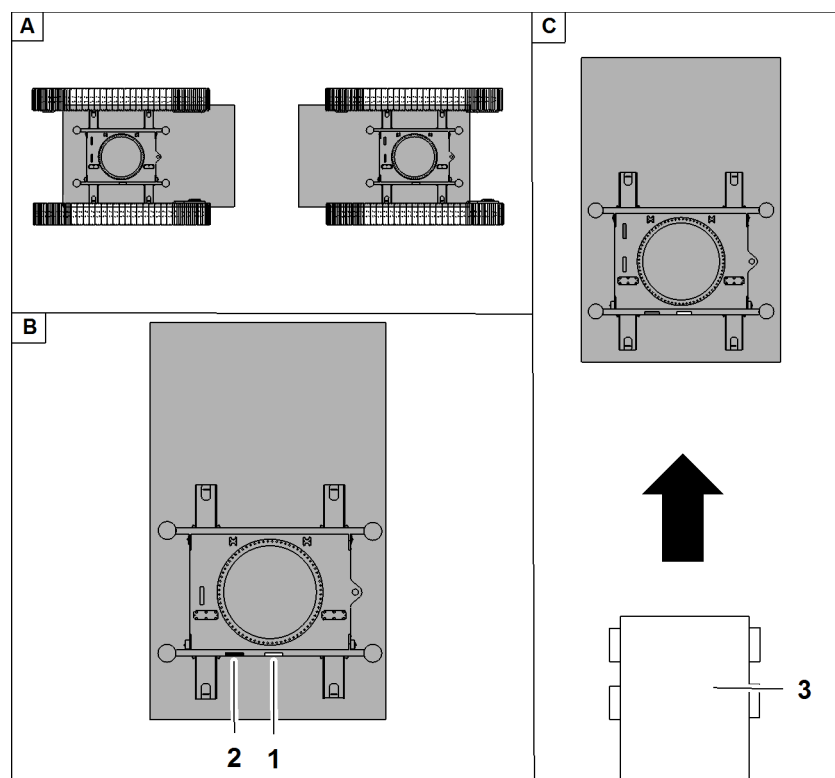

Fig. 1634: Uppercarriage positions when disassembling the machine with self-loading system*

- | | | | |
|---|-------------------------------------|---|---|
| 1 | Locking link plate of undercarriage | A | Positions of uppercarriage for deinstalling the crawler side frames |
| 2 | Locking link plate of uppercarriage | B | Positions of uppercarriage for installing the uppercarriage lock |
| 3 | Transport vehicle | C | Access path of transport vehicle |



WARNING

Undesired rotation of uppercarriage!
Risk of crushing of limbs.

- ▶ Make sure that the uppercarriage lock is installed when shutting down, prior to transport, prior to maintenance work and repair work.

LB 36 center of gravity position of machine (standard design without options, without rotary drive and Kelly bar)			
Counter-weight	Total weight (with empty tank)	X	Z
5 t (11,023 lb) +	100.5 t 221,561 lb	-690 mm -27.17" in	1867 mm 6' 2" ft-in
5 t (11,023 lb) +			
12 t (26,455 lb)			

Tab. 83: LB 36 center of gravity position of machine (benchmarks for machines with standard design without options, negative values behind center of rotation)

8.1.4 Rigging the machine

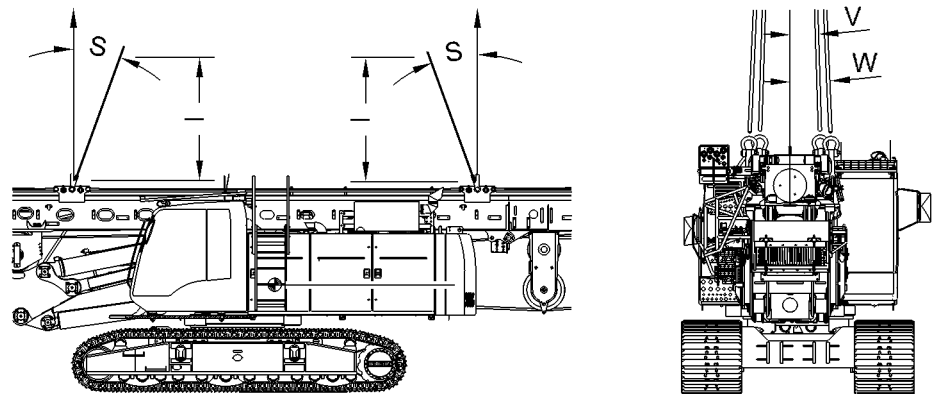

Fig. 1641: Rigging the machine

S Longitudinal rigging angle **V** Angle rear rigging
I Length of lifting equipment **W** Angle front rigging

- ▶ Limit longitudinal rigging angle **S** to maximum 30°.
- ▶ Widen rear rigging angle to **V** 1.8°.
- ▶ Widen front rigging angle to **W** 2.5°.

8.1.5 Lifting the machine



DANGER

Incorrect lifting of machine!
 Danger of falling.

- ▶ Perform all movements slowly and carefully.
 - ▶ Make sure that the machine is suspended horizontally.
-
- ▶ Level machine and readjust hoisting crossbars if necessary.
 - ▶ Check whether the machine lifts off the ground on all corners.

**DANGER**

Incorrect lashing on low loader!
Toppling of machine.

- ▶ Ensure that the lashing capacity (LC) of the chain is at least 200 kN (44,960 lb_f) (if used doubly 100 kN (22,480 lb_f)).
- ▶ Ensure that the chain length **L** is at least lashing point height **H**.
- ▶ Longitudinal distance between lashing points **Z** must be at least 0.325 x lateral distances between lashing points **B**.

Name		Value
a	Angle a	max:90°
b	Angle b	min:0°, max:72° (72°)

Tab. 89: Chain angle in acc. with DIN EN 12195-1

- ▶ Observe admissible chain angles in acc. with DIN EN 12195-1.
- ▶ Use the front **3** and rear lashing points **4** to lash the basic machine in a cross pattern on the low loader.
- ▶ Attach leader lashing (4x) **1**.
- ▶ Lashing should be checked continuously throughout the entire transportation process; retighten as necessary.

8.3.4 Transporting the basic machine with crawler side frame and counterweight using a low loader

Basic machine rests on center part

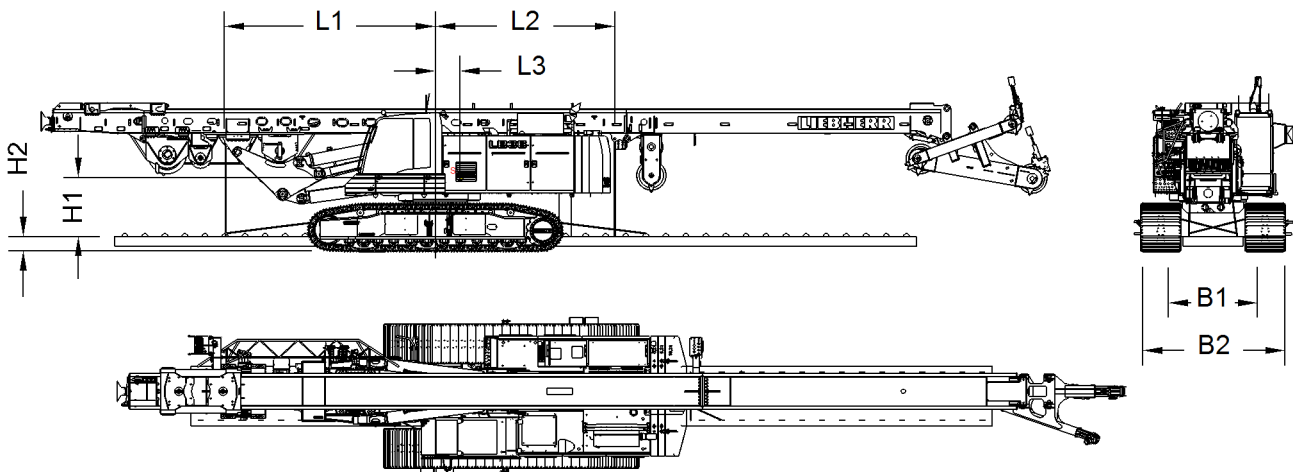

Fig. 1647: Dimensions basic machine with crawler side frame and counterweight - basic machine rests on center part

8.3.8 Transporting the top part of leader (1700 mm (5' 7" ft-in) leader top*)

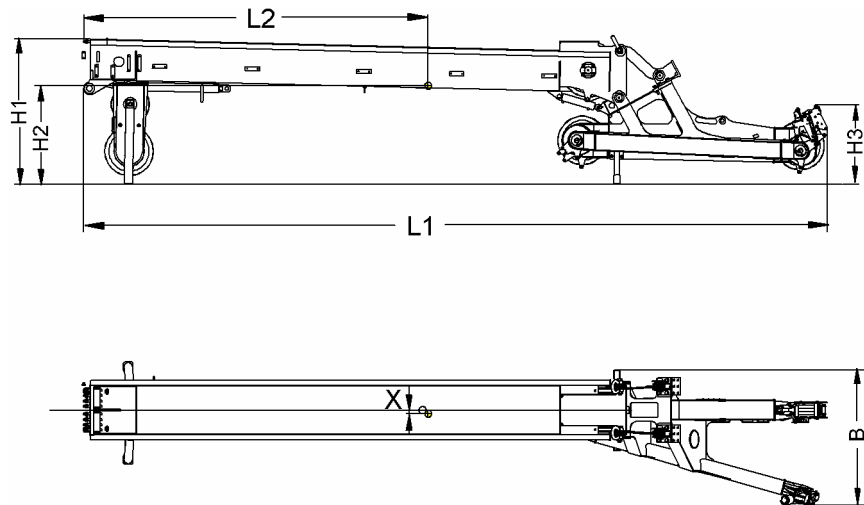

Fig. 1656: Dimensions top part of leader (1700 mm (5' 7" ft-in) leader top)

Name		Value
H1	Height of top part of leader	2192 mm 7' 2" ft-in
H2	Height up to center of gravity	1384 mm 4' 6" ft-in
H3	Height up to leader top rope guide	1199 mm 3' 11" ft-in
L1	Length of top part of leader	11222 mm 36' 10" ft-in
L2	Length up to center of gravity	5381 mm 17' 8" ft-in
X	Distance between center of leader and center of gravity	57 mm 2.24" in

Tab. 99: Dimensions top part of leader (1700 mm (5' 7" ft-in) leader top)

Customer:.....Machine type:.....Serial no.:.....Operating hours:.....Date:.....

Maintenance / inspection after service hours							Tasks to be performed			
8h/Daily	40h/Weekly	500h/Quarterly	1000h/Every six months	2000h/Annually	4000h/2 years	6000h/3 years	Special intervals	By maintenance staff ■ Once-only activity ● Repeat interval † If necessary * Annually before the winter	by Liebherr service personnel □ Once-only activity ○ Repeat interval ✧ If necessary	See page
	●									803
●										804
Hydraulic system										
●										805
	●									805
			○							
		□	○							806
Hydraulic oil tank										
								●		808
								●		808
								●		808
								●		808
								●		808
								●		808
			○							
	●		○							810
		□	○							812
Hydraulic oil heater										
			○							
Accumulator										
			○							
					○					
Hydraulic cylinders										
			○							815
	●									815
								†		815
Hydraulic leads										
	●									816
				●						

9.2.3 Lubrication chart

No.	Lubrication spots	Outside temperature	Type	Specification	Liebherr
			ISO VG/SAE		Lubricants
1	Diesel engine stage 0 to 3B/ tier 0 to 4i	all year around down to -20 °C (-4 °F) below -20 °C (-4 °F) with pre-heating	SAE 10W-40	ACEA E4 API CF	Liebherr Motoroil 10W-40
		all year around down to -20 °C (-4 °F) below -20 °C (-4 °F) with pre-heating	SAE 10W-40 low ash	ACEA E4-99 / E6 / E7 API CF-4 / CG-4 CH-4 / CI-4	Liebherr Motoroil 10W-40 low ash required when using particulate filters
	Diesel engine stage IV/tier4f	all year around down to -30 °C (-22 °F) below -30 °C (-22 °F) with pre-heating	SAE 5W-30	ACEA E4 / E7 API CF	Liebherr Motoroil 5W-30
		all year around down to -30 °C (-22 °F) below -30 °C (-22 °F) with pre-heating	SAE 5W-30 low ash	ACEA E6 / E7	Liebherr Motoroil 5W-30 low ash required when using particulate filters
2	Mechanical gearboxes, winches and drive axles	down to -25 °C (-13 °F) down to -40 °C (-40 °F)	SAE 85W-90 ISO VG 220	API GL 5 DIN51 502	Liebherr Hypoid EP 90 Liebherr Syntogear Plus 220
		to -50 °C (-58 °F) + 30 °C (86 °F)	SAE 75W-90	API GL 4; GL 5; MT 1	Liebherr Syntogear Plus 75W-90
		3	Hydrostatic drive, hydro-steer	to -25 °C (-13 °F) + 50 °C (122 °F) ^{B)}	ISO VG 32 - 46 SAE 10W-20 ATF ^{A)}
to -25 °C (-13 °F) + 50 °C (122 °F) ^{B)}	ISO VG 46 (32-68) SAE 10W-20			DIN 51 524 / T3 HVLPD HC in acc. with CEC- L-33-A-93	Liebherr Hydraulic Plus biodegradable
to -50 °C (-58 °F) + 30 °C (86 °F)	ISO VG 15 - 46 SAE 0W-20			DIN 51 524 / T3 HVLPD HC in acc. with CEC- L-33-A-93	Liebherr Hydraulic Plus Arctic biodegradable
4	Hydraulic additive for free-fall brake			DIN 51 757 DIN 51 562	Liebherr special additive NL

9.3 Work instructions for preventive maintenance

**WARNING**

Entering working range and danger zone while machine is running is not permitted!
Death, risk of crushing limbs.

- ▶ Ensure that the machine operator sits in the cabin when the machine is running.
- ▶ Carry out work on machine under visual and radio contact with machine operator.

**WARNING**

Improper preventive maintenance of machine!
Death, grave injury.

If work on machine is performed without machine operator:

- ▶ Switch off main battery switch.

If work is performed on electrical systems or if extensive maintenance work has to be performed:

- ▶ Switch off main battery switch.

**WARNING**

Inadmissible opening of uppercarriage liner doors!
Injuries.

- ▶ Make sure that uppercarriage liner doors are only opened when engine is turned off and with the system cooled down and depressurized.

**WARNING**

Insufficient lighting!
Fall from machine.

- ▶ Make sure that machine is only accessed and entered in sufficient lighting.
- ▶ Make sure that preventive maintenance work on the machine is only performed in sufficient lighting.

**WARNING**

Inadmissible stay on platform of rotary drive!
Fall from platform.

- ▶ Make sure persons only stay on the platform when the universal carriage and the rotary drive stand still.
- ▶ Make sure that only one person is located on the platform.

**WARNING**

Insufficient visual contact between machine operator and person on platform of rotary drive!
Fall from platform.

- ▶ Make sure that person on the platform is always within machine operator's field of vision.

9.8 Swing

9.8.1 Checking the gearbox oil level

Ensure that the following conditions are fulfilled:

- Diesel engine has been switched off for five minutes.
- The machine is level.
- The machine is secured to prevent unauthorised operation.

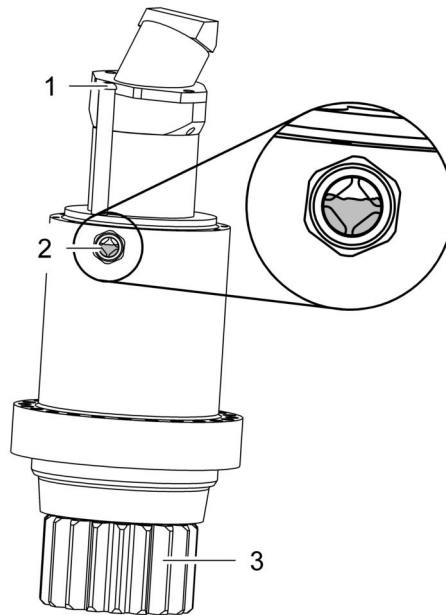

Fig. 1682: Checking the gearbox oil level

- | | |
|---|-----------------|
| <p>1 Filler neck</p> <p>2 Sight glass</p> | <p>3 Pinion</p> |
|---|-----------------|

- ▶ Check the gearbox oil level in the sight glass 2.

If no gearbox oil is visible in the sight glass:

- ▶ Top up using appropriate gearbox oil in accordance with the lubrication chart ([For more information see: 9.8.2 Topping up the gearbox oil, page 777](#)).

9.8.2 Topping up the gearbox oil

Ensure that the following conditions are fulfilled:

- Diesel engine has been switched off for five minutes.
- The machine is level.
- The machine is secured to prevent unauthorised operation.

NOTICE

Dirt and foreign bodies in the swing gear!
Damage to the swing gear.

- ▶ Ensure that no dirt or foreign bodies enter the filler neck.
-

- ▶ Open the cover: turn the cover counter-clockwise.

**Note**

If the measurement length of the chain is smaller than 1 m (3' 3" ft-in) or larger than 1.5 m (4' 11" ft-in):

- ▶ Make sure that the admissible slackening value increases or decreases linearly.
- ▶ Make sure that the measuring length involves at least four chain links.

9.14.6 Adjusting chain tension

**CAUTION**

Inadmissible operation of crawler!
Risk of crushing limbs.

- ▶ Make sure that diesel engine is switched off.
- ▶ Make sure that the machine is secured against unauthorized startup.

NOTICE

Inadmissible chain tension!

In case of insufficient chain tension: Chain slides out of guide.

In case of excess chain tension: Increased chain wear.

- ▶ In case of insufficient chain tension: Tension chain as described in the following.
- ▶ In case of excess chain tension: Relax chain as described in the following.

9.14.7 Retightening chain

Make sure the following conditions are met:

- Machine is level.
- Machine is secured against unauthorized startup.
- Chain is clean.
- Stuck objects have been removed from chain.
- Grease gun from Liebherr tool kit is available and filled with correct grease ([For more information see: 9.2.3 Lubrication chart, page 757](#)).
- The required tools from the Liebherr tool kit are available.

- ▶ Start diesel engine and allow it to idle for 5 minutes.
- ▶ Turn off diesel engine and again tighten nut **7** of bottom part of housing **6** all the way to the stop.
- ▶ Start diesel engine and allow it to idle.
- ▶ Check hydraulic system for leaks.

If hydraulic system leaks:

- ▶ Contact Liebherr customer service.

9.21 Bypass filter system

9.21.1 Checking the bypass filter system

Make sure the following prerequisites are met:

- Hydraulic oil is at operating temperature.
- ▶ Read dynamic pressure manometer on bypass flow filter.

If the dynamic pressure manometer of the bypass flow filter shows 1 bar (14.50 psi) above the initial value (normal value):

- ▶ change the filter elements.

9.21.2 Changing the filter elements

Ensure that the following conditions are fulfilled:

- Diesel engine has been switched off for 5 minutes.
- Machine is level.
- Machine is secured against unauthorized start-up.



Note

Liebherr recommends:

- ▶ If the machine is subjected to heavy work: halve the exchange interval.
-

The filter elements cannot be cleaned and must be disposed of in accordance with the national and international regulations and guidelines.

9.25 Limit switches

9.25.1 Checking the function of the drilling equipment's hoist limit switches and limit switches

- ▶ Check function of the limit switches: trigger limit switches.

If the activated limit switch does not register on the monitor:

- ▶ Contact Liebherr after sales service.

9.25.2 Checking the hoist limit switches for tight fit and function

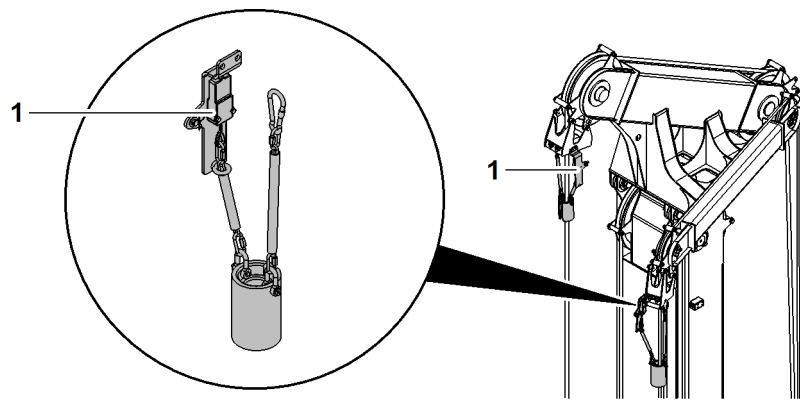

Fig. 1723: Hoist limit switch (illustration of principle)

1 Hoist limit switch

- ▶ Check hoist limit switch 1 for tight fit.
- ▶ Check mobility of limit switch rigging.

If limit switch rigging is not mobile:

- ▶ Spray limit switch rigging with adhesion lubricant.
- ▶ Carefully drive hook/equipment against weight of hoist limit switch.
 - ▷ Hoisting movement of the corresponding winch is blocked.

9.25.3 Checking the limit switch of the drilling rig for attachment and function

The limit switches of the drilling rig are: feed limit switch, hoist limit switch and tilt limit switch.

9.33 Repair welding

9.33.1 Welding requirements



DANGER

Improper welding!
Structural breakdown.

- ▶ Observe the international and national safety and accident prevention regulations and the "Principles for the testing of cranes by specialists and experts according to the accident prevention regulations "Cranes" BGV D6 and BGG 905" (formerly: VBG 9)".
- ▶ Repair instructions, specifying the basic material and the relevant welding consumables and auxiliary agents, must be requested from Liebherr customer service. These instructions must be observed.
- ▶ All necessary non-destructive tests must be carried out and documented.

Ensure that the following conditions are fulfilled:

- Authorized personnel are available.
- Authorized service personnel who have passed the corresponding welding qualification tests laid down in EN 287-1 for the material and welding method in question are available.
- Enterprises holding a major qualification certificate according to DIN 18800-7, DIN 15018 and DIN 4132 with the extension for cranes, crane tracks and the following high-strength and highest-strength fine-grained structural steel, have available:
 - Steel sheet S690QL1 W. No. 1.8988
 - Steel sheet S690QL W. No. 1.8928
 - Steel sheet S700MC W. No. 1.8974
 - Tubes S770QL W. No. 1.8938
 - Steel sheet S960QL W. No. 1.8933
 - Steel sheet S960MC W. No. -
- Manual arc welding certificate E (111) is available.
- Experience in the repair of mobile and crawler cranes with the relevant materials and use of welding methods MAG (135).
- Repair welding must satisfy the requirements of EN 25817-B.
- ▶ Perform the repair welding in accordance with applicable regulations.







Note

- ▶ Request the necessary test loads and element configurations from Liebherr customer service.
- ▶ Subject the repaired component to a load test.
- ▶ Document the performed test.

Crane reference						Rope application					
Rope details											
Brand name (if known)											
Nominal diametermm											
Construction.....											
Core ^a : IWRC FC WSC											
Wire finish ^a : Uncoated Zinc/Gal.											
Direction and type of lay ^a : (Right) sZ zZ Z (Left) zS sS S											
Permissible number of visible broken outer wires in 6d and..... in 30d											
Reference diameter.....mm											
Permissible decrease in diameter from reference diameter mm											
Date installed (yy/mm/dd)..... Date discarded (yy/mm/dd).....											
Visible broken outer wires				Diameter			Corrosion	Damage and/or deformation		Position in rope	Overall assessment i.e. combined severity rating ^b at position indicated
Number in length of		Severity rating ^b		Measured diameter mm	Actual decrease from reference mm	Severity rating ^b	Severity rating ^b	Nature			
6d	30d	6d	30d								
Other observations/comments											
Performance to date (cycles/hours/days/months/etc.)											
Date of inspection (yy/mm/dd).....											
Name (print) of competent personName (signature)											
^a Tick as applicable.											
^b Describe degree of deterioration as: slight, medium, high, very high, or discard.											

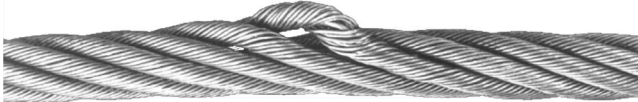
Fig. 1736: Example of an individual report

Check for:	Images of damage:
<p>Corkscrew: With this deformation, the axis of the unstrained wire rope takes on a spiral shape. This does not weaken the wire rope but may cause uneven running of the rope. Higher wear and wire brakes may be the consequences. If this deformation is more than 1/3 of the nominal rope diameter in the weakest spot, the wire rope must be exchanged.</p>	
<p>Abrasion: Abrasion may reduce both the static rope breaking force due to a reduction of the metal rope diameter, and the operational stability due to wear notches. If the rope diameter has shrunk on longer stretches by more than 10% compared to the nominal dimension, the rope must be exchanged – even if there are no wire breaks.</p>	
<p>Deformed core or strand: Core emerges between the outer strands or outer strand emerges from the rope structure.</p>	
<p>Local increase of rope diameter: Caused by deformation of the rope core or swelling of the fiber core.</p>	

9.38 Rope pulleys

9.38.1 Assembly of a pulley

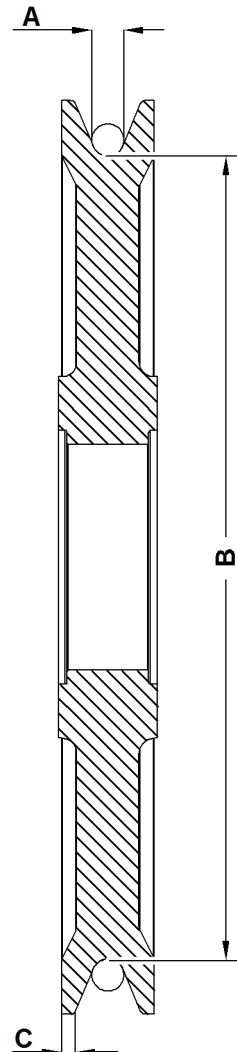

Fig. 1758: Assembly of a pulley (illustration of principle)

- | | | | |
|----------|---------------------------|----------|-----------|
| A | Groove diameter | C | Gap width |
| B | Bottom of groove diameter | | |

9.38.2 Checking the groove diameter of the pulley

According to ISO 16625, the groove diameter of the pulley must be between 5% and 10% greater than the nominal diameter of the rope.

Make sure the following prerequisites are met:

- Suitable groove gauge is available.
- Groove is free of grease deposits.
- Machine is switched off.
- Machine is secured against unauthorized start-up.

9.40 Cabin

9.40.1 Checking the windows of the cabin for damage

- ▶ Check the windows of the cabin for damage.

If any of the cabin windows are damaged:

- ▶ Replace the window.
- ▶ Contact Liebherr customer service.

9.40.2 Cleaning the cabin windows



DANGER

Unsecured work on uppercarriage and cabin!
Risk of falling off the uppercarriage.

- ▶ A fall arrest system must be worn when working on the uppercarriage.
- ▶ Do not step on the cabin's roof window.
- ▶ Roof window may only be cleaned on platform with suitable aids.

- ▶ Clean windows.

If the machine has a foldable cabin roof protection guard or falling object protection:

- ▶ Fold up cabin roof protection guard or falling object protection.
- ▶ Open latch from safe standing position.
- ▶ Fold up cabin roof protection guard from safe standing position.
- ▶ Clean cabin roof window from safe standing position.



WARNING

Inadmissible position of cabin roof protection guard or falling object protection!
Protection by cabin roof protection guard or falling object protection no longer ensured.

- ▶ Only fold up cabin roof protection guard or falling object protection for cleaning.
- ▶ Only operate and transport machine with cabin roof protection guard or falling object protection folded down and latched.
- ▶ Fold down cabin roof protection guard or falling object protection and latch.

9.40.3 Checking the function of the cabin door and door lock

Checking the operation of the cabin door

- ▶ Check the operation of the cabin door.

If the cabin door does not move freely or does not latch in the open position:

- ▶ Spray the hinges with adhesive lubricant.
- ▶ Contact Liebherr customer service.

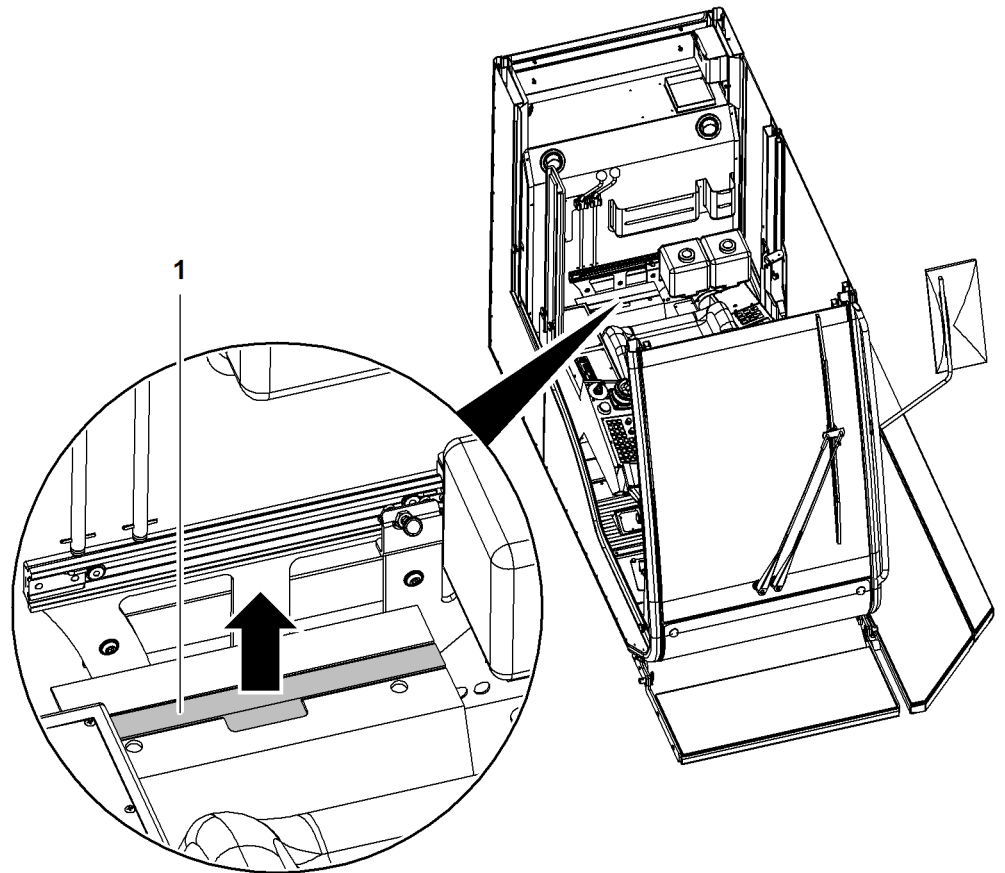

Fig. 1776: Removing recirculated air filter

1 Recirculated air filter

► Remove recirculated air filter 1.



Note

Improper installation of recirculated air filter 1!

Improperly installed recirculated air filter 1 reduces air conditioner performance.

► Observe installation direction of recirculated air filter 1.

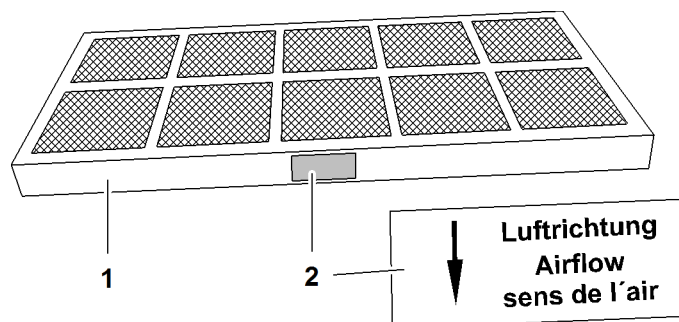

Fig. 1777: Recirculated air filter

1 Recirculated air filter

2 Sign

The arrow of the sign 2 must point toward the operator's seat when installing the recirculated air filter 1.

► Replace recirculated air filter 1.

- ▶ Check fan on condenser for damage.
- ▶ Turn on air conditioner.

If the fan on the condenser does not turn:

- ▶ Contact Liebherr customer service.

9.41.9 Checking the climate box for contamination

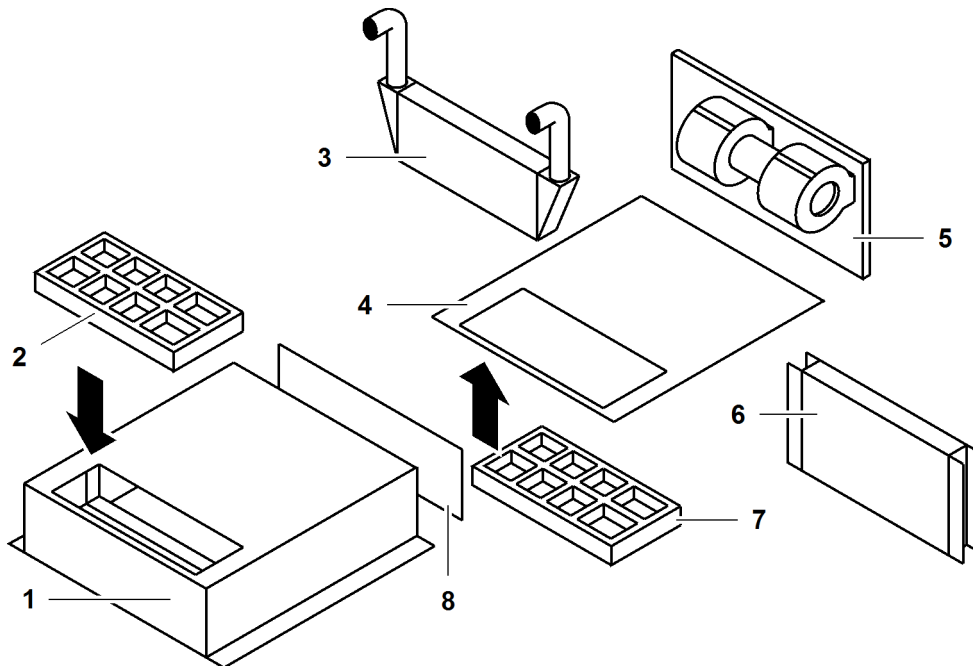

Fig. 1789: Checking the climate box for contamination (illustration of principle)

1	Climate box	4	Bottom plate of climate box	7	Fresh air filter
2	Recirculated air filter	5	Fan	8	Flap recirculated air/fresh air
3	Heat exchanger	6	Vaporizer		

When replacing the fresh air filter **7**, it is possible to check for contamination through the opening of the heat exchangers **3**.

- ▶ Check heat exchanger **3** for contamination.

If heat exchanger **3** is dirty:

- ▶ Clean heat exchanger **3**.

When replacing the recirculated air filter **2**, it is possible to check the ease of movement of the recirculated air/fresh air flap **8**.

- ▶ Check recirculated air/fresh air flap **8** for movement.

If the recirculated air/fresh air flap **8** cannot be moved:

- ▶ Contact Liebherr customer service.

CLICK HERE TO **DOWNLOAD** THE COMPLETE MANUAL

- Thank you very much for reading the preview of the manual.
- You can download the complete manual from: www.heydownloads.com by clicking the link below



- Please note: If there is no response to CLICKING the link, please download this PDF first and then click on it.

CLICK HERE TO **DOWNLOAD** THE COMPLETE MANUAL