

en

Operator's manual

Wheel loader

Document ID

	ORIGINAL OPERATOR'S MANUAL
Order number:	12203963
Issued:	07-2019
Version:	16
Author:	LBH / Technical Documentation Department

Product ID

Manufacturer:	Liebherr-Werk Bischofshofen GmbH
Type:	L 538
Type no.:	1559 (USA / CAN)
From Serial no.:	41579

Contact

Liebherr-Werk Bischofshofen GmbH
Dr. Hans Liebherr-Straße 4
A – 5500 Bischofshofen

CLICK HERE TO **DOWNLOAD** THE COMPLETE MANUAL

- Thank you very much for reading the preview of the manual.
- You can download the complete manual from: www.heydownloads.com by clicking the link below



- Please note: If there is no response to CLICKING the link, please download this PDF first and then click on it.

CLICK HERE TO **DOWNLOAD** THE COMPLETE MANUAL

3.4.2	Transporting and moving material	206
3.4.3	Emptying the working attachment	207
3.4.4	Handling materials with high dump buckets	208
3.4.5	Loading with clamp buckets	209
3.4.6	Grading work	209
3.4.7	Removing material from a slope or wall	210
3.4.8	Loading a transport vehicle	212
3.4.9	Excavation	214
3.5	Fitting and removing the attachment	216
3.5.1	Hydraulic connections for hydraulic working attachment	216
3.5.2	Removing the working attachment from the quick coupler	216
3.5.3	Fitting working attachments to the quick coupler	219
3.6	Transport	223
3.6.1	Transporting the machine	223
3.6.2	Transport safety retainer	227
3.7	Emergency modes	229
3.7.1	Lowering the lift arms if the diesel engine fails	229
3.7.2	Recovering and towing the machine	230
3.7.3	Emergency steering	237
3.7.4	Jump starting procedure	238
4	Malfunctions	241
4.1	Servicecodes	241
4.1.1	Service code indicator in the display	241
4.2	Problems - Cause - Remedy	242
4.2.1	Warning symbols	242
4.2.2	SCR system warning symbols	243
4.2.3	Troubleshooting for the diesel engine and fuel system	243
4.2.4	Troubleshooting the Liebherr central lubrication system	247
4.3	Problem remedy	249
4.3.1	Replacing fuses	249
5	Maintenance	255
5.1	Maintenance and inspection schedule	255
5.2	Filling quantities and lubrication chart	260

Description	Unit	Value
Maximum flow rate	l/min	170
	gal/min	44.91
Maximum operating pressure	bar	350 ^{±5}
	psi	5,076.30 ^{±72.52}

1.2.11 Lift arms

Lift arm versions:

- Z kinematics
- Parallel kinematics

Working cycle time at rated load with Z kinematics

Description	Unit	Value
Lifting	s	5.0
	s	5
Tilting out	s	2.9
Lowering (empty)	s	3.8

Working cycle time at rated load with parallel kinematics

Description	Unit	Value
Lifting	s	5.0
	s	5
Tilting out	s	4.3
Lowering (empty)	s	3.8

1.2.12 Cab

Design:

- Elastically mounted, soundproofed cab
- Cab door with:
 - 105° opening angle and side window with 5° vent opener or
 - 180° opening angle with fixed window.
- Right side window with 5° vent opener or 40° opening
- Front window in green-tinted compound safety glass as standard
- Side window in grey-tinted single-pane safety glass
- Infinitely adjustable steering column
- Heated rear window
- ROPS rollover protection in accordance with EN/ISO 3471/EN 474-1
- FOPS stone impact protection in accordance with EN/ISO 3449/EN 474-1, Cat. II

Driver's seat

6-position, shock-absorbing driver's seat, adjustable to the driver's weight.

	Designation	Unit	Value	
			kg	lb
	Operating weight	kg lb	13900 30,644	14160 31,217

Tab. 8: Complete machine with bucket (parallel kinematics)

- A) Earth bucket with short, straight base for quick coupler
- B) Welded tooth holder with plug-in teeth
- C) High lift
- D) In practice, the bucket capacity can be around 10% greater than as calculated using the ISO 7546 standard. This depends on the type of material.
- E) With the optional comfort safety door, the value increases by 130 mm (5.12" in) when the door is open.

1.2.23 Working attachment: light material bucket

Values stated refer to machine:

- In standard version
- With 20.5R25 L3 tyres (For more information see: 1.2.18 Tyres, page 23)
- Including all lubricants
- With a full fuel tank
- With ROPS/FOPS cab and operator
- On level and stable ground



Note

Tyres and working attachments affect operating weight and tipping load.

► Note the information about the tyres and working attachment.

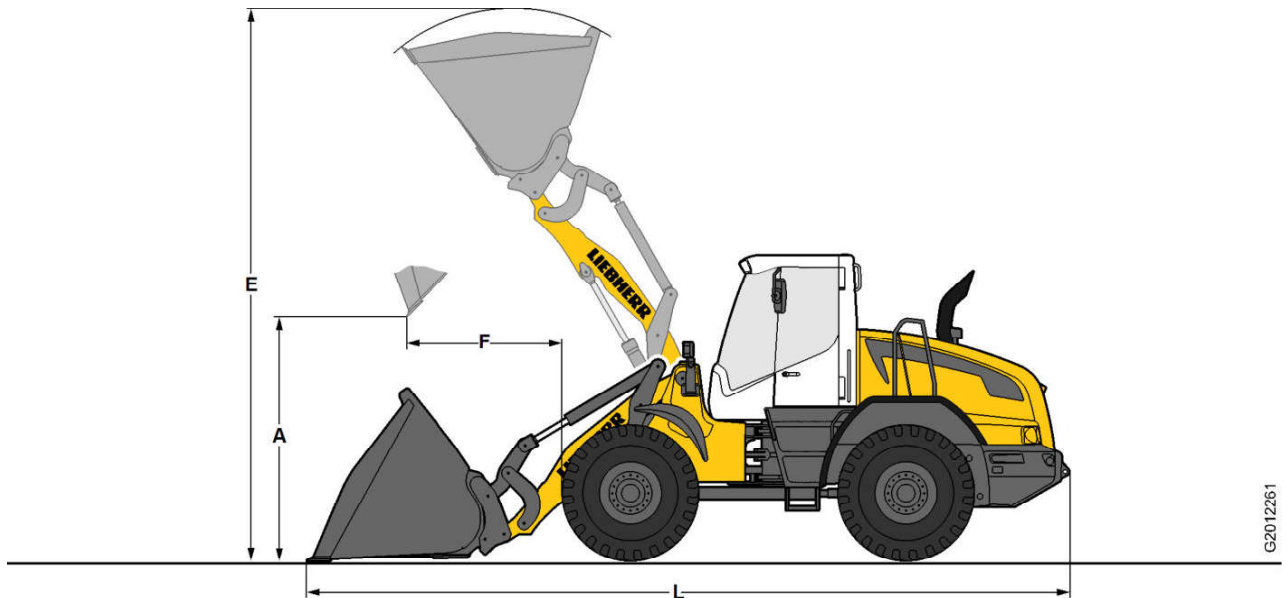

Fig. 5: Working attachment: light material bucket

Designation	Unit	Value			
		Yes	Yes	Yes	Yes
Hydraulic quick coupler		Yes	Yes	Yes	Yes
Load geometry		A)	A)	A)	A)

LBH/12203963/16/07-2019/en

G2012261

2 Safety instructions

2.1 Information on these instructions

2.1.1 Representation of warning messages

Warning symbol

	The warning symbol warns of potential dangers. Obey all measures marked with this symbol to avoid injury or death.
-----------------------------------------------------------------------------------	--------------------------------------------------------------------------------------------------------------------



Tab. 13: Warning symbol

Grading of warning messages

The grading of warning messages is defined by following signal words:

- DANGER**
- WARNING**
- CAUTION**
- NOTICE**

Definition of warning levels

	DANGER	Indicates an immediately hazardous situation which, if not avoided, will result in death or serious injury.
	WARNING	Indicates a hazardous situation which, if not avoided, could result in death or serious injury.
	CAUTION	Indicates a hazardous situation which, if not avoided, could result in minor or moderate injury.
	NOTICE	Indicates a hazardous situation which, if not avoided, could result in property damage.

Tab. 14: Warning levels

2.1.2 Graphic symbols in these instructions

Symbol	Meaning
	Note Identifies useful information and tips.

LBH/12203963/16/07-2019/en

	Safety decal	Description
3		Articulation area decal Warns of the risk of accidents, possibly resulting in severe or even fatal injuries. Meaning: Keep out of the articulation area when it is not secured.
4		Steering decal Warns of the risk of accidents, possibly resulting in severe or even fatal injuries. Meaning: The steering is only operational when the engine is running.
5		Accident prevention decal Refers to the instructions in the operating manual for preventing accidents. Meaning: Strictly observe the accident prevention instructions in the operating manual when operating the machine.
6		Safety belt decal Warns of the risk of accidents, possibly resulting in severe or even fatal injuries. Meaning: Fasten your safety belt before starting up the machine.
7		Cooling water decal Warns of the risk of scalding and severe injuries caused by coolant escaping under pressure. Meaning: Do not open the cap on the filler neck until the engine has cooled down.
8		Burn hazard decal Warns of the risk of burns, possibly resulting in severe injuries. Meaning: Only touch when the parts have cooled down.
9		Voltage decal Refers to the battery main switch. Meaning: The electrical system is energised when the battery main switch is turned on.
10		Engine shutdown decal Warns of the risk of accidents, possibly resulting in severe injuries. Meaning: Only open when the engine is shut down.

Tab. 16: Safety decals

Damage

Increased travel mode

- If machine is driven a lot: Stipulate use of special auxiliary systems for travel mode.
- Regulate speed to prevent swaying.

2.7.8 Operation of machine

Danger to life

Incorrect place of use









- Make sure that load capacity value of ground is sufficient.
- Do not exceed maximum inclination angle of machine while working.
- Do not exceed maximum inclination angle of machine when driving on ramps (side inclination).
- Make sure that ground offers sufficient grip.
- Assessment of subsoil conditions before starting work
- Adhere to safety gap from live overhead cables.
- Every line must be considered live.
- Keep a safe distance from overhangs, drops, slopes and unsafe terrain.

Incorrect use

- When working in following areas, adhere to the laws, regulations and rules applicable at the place of use.
 - Explosive area
 - Flammable area
 - Areas with underground lines (gas, electricity)
- Ensure that machines in enclosed spaces (for example, tunnels, hangars) are equipped with exhaust reduction components.
- Make sure that adequate ventilation and fresh air supply is ensured when operating in enclosed spaces.
- Never leave operator's seat while machine is still in motion.
- Never leave machine unattended with engine running.
- Clean machine regularly to remove flammable residues (for example dust, wood scraps).

Incorrect handling of electrical system

- Make sure there are no persons with a pacemaker in the vicinity of the running diesel engine.
- Before working on electrical system, make sure that affected parts are voltage-free.
- Before working on electrical system, make sure that neighbouring parts are isolated.
- Have work on electrical systems performed exclusively by a qualified electrician.

Symbol	Designation	Symbol	Designation
	Rear windscreen washer system button/switch		Flashing beacon switch (option) ^{A)}
	Visible reversing alarm switch (option)		Audible reversing alarm switch (option)
	Working basket switch (option)		On-road travel switch (option)
	2in1 steering switch (option)		Diesel particulate filter switch/button

Tab. 19: Switches and buttons

A) The function can also be activated when the ignition key is taken out.

3.1.5 Control lever

Use the control lever to control the travel direction and movements of the working attachment.

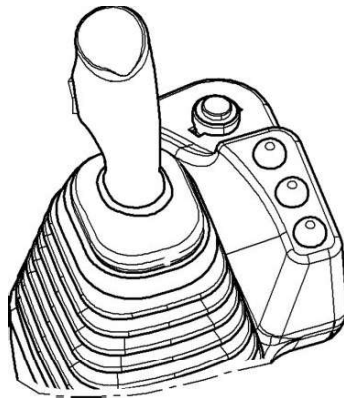

G2000856

Fig. 59: Control lever

(For more information see: [3.2.17 Control lever](#), page 134)

Operator's seat: Grammer mechanical

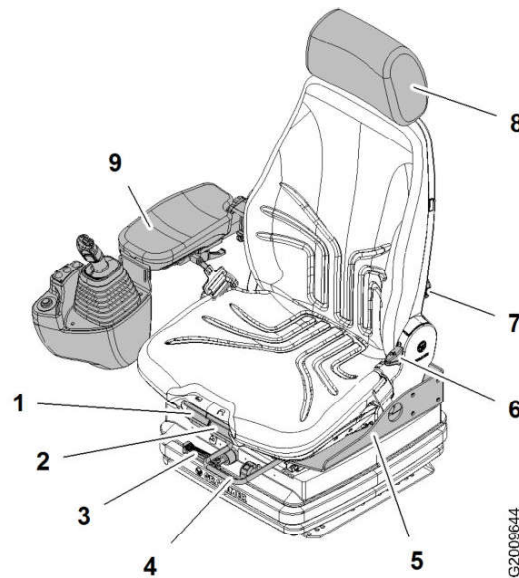
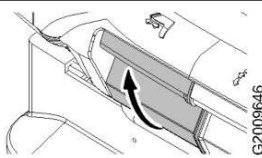
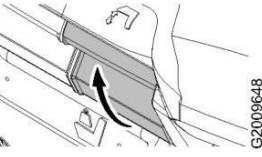
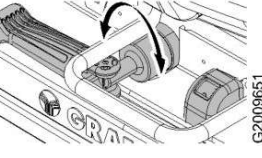
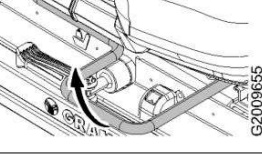
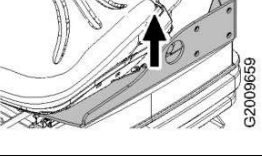

Fig. 73: Operator's seat: Grammer mechanical

Adjustment options		
1	 G2009646	Seat cushion depth adjustment Pull up the lever and move the seat cushion.
2	 G2009648	Inclination adjustment Pull up the lever and adjust the seat inclination by putting more or less weight on the front of the seat cushion.
3	 G2009651	Weight adjustment Turn the lever and set the driver's weight. The set driver's weight is shown in the sight glass.
4	 G2009655	Horizontal adjustment Pull the lever all the way up and move the operator's seat.
5	 G2009659	Height adjustment Lift up the operator's seat as necessary until you hear it catch. When you raise the operator's seat above the highest notch it sinks to the lowest position.

LBH/12203963/16/07-2019/en

**WARNING**

Always wear a safety belt!
Injury.

- ▶ Always wear safety belt before putting machine into service.

Fastening safety belt

Make sure that following requirements are fulfilled:

- Condition, function and fastening have been checked.
- Damaged parts have been replaced.
- The safety belt is not twisted.
- A proper seating position is adopted.

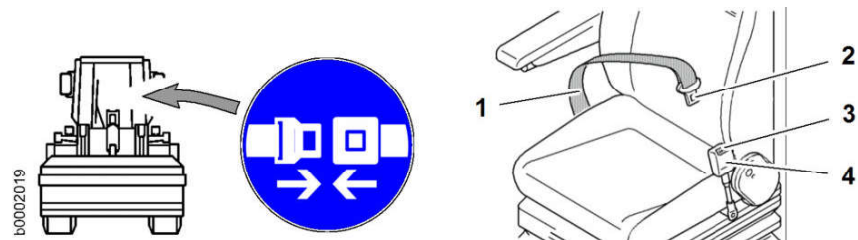

Fig. 127: Safety belt

- 1 Strap
- 2 Lug

- 3 Release button
- 4 Belt lock

- ▶ To fasten the safety belt: pull the strap 1 over your lap and lock the lug 2 into the belt lock 4.
- ▶ To release the safety belt: press the release button 3.

3.2.9 Steering wheel

You can change the height of the steering wheel and the distance from your body by adjusting the steering column. This adjustment is continuous.

**WARNING**

Uncontrolled steering movements!
Risk of injury.

- ▶ Only adjust the steering wheel when the engine is switched off.

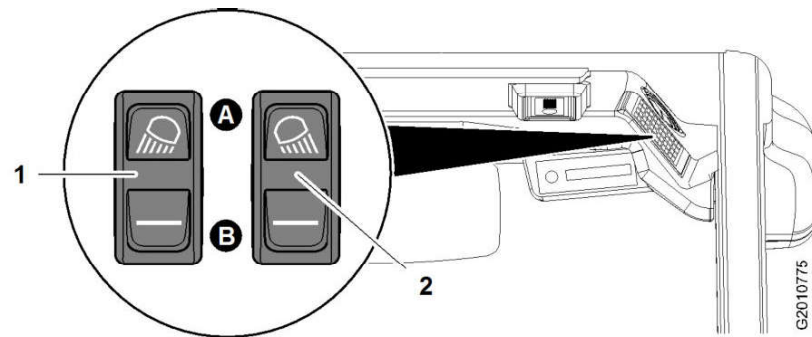

Fig. 142: Working headlights

1 Front working headlights switch 2 Rear working headlights switch

- ▶ To switch on the front working headlights: push the switch 1 to position A.
- ▶ To switch off the front working headlight: push the switch 1 to position B.
- ▶ To switch on the rear working headlights and the engine bonnet working headlights: push the switch 2 to position A.
- ▶ To switch off the rear working headlights and the engine bonnet working headlights: push the switch 2 to position B.

Working headlight for backward travel direction

This equipment is optional.

The function automatically switches the rear working headlights on when driving backwards and off when driving forwards.



WARNING

The working headlights can become hot!
Burns, fire.

- ▶ Observe the minimum interval of 1 m (3' 3" ft-in) to persons and material.

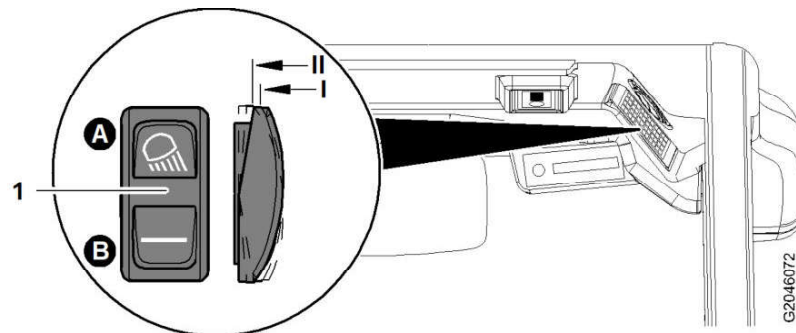

Fig. 143: Working headlight for backward travel direction

1 Rear working headlights switch

- ▶ Activate rear working headlight for rear travel direction: push switch 1 to position A in position I.
 - ▷ Rear working headlights are switched on in reverse travel direction.
- ▶ Switch on rear working headlight for forward and reverse travel direction: push switch 1 to position A in position II.
- ▶ To switch off rear working headlight: push switch 1 to position B.

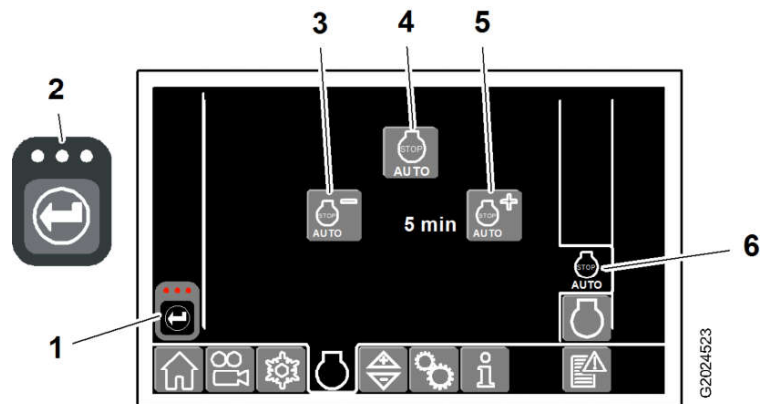

Fig. 169: Automatic engine shut down

- | | | | |
|---|-------------------------------------|---|----------------------------------------------------|
| 1 | Confirmation required status symbol | 4 | Activate and deactivate automatic engine shut down |
| 2 | Confirmation key | 5 | Increase engine shut-off time |
| 3 | Reduce engine shut-off time | 6 | Automatic engine shut down button |

- ▶ Call up the display screen using button 6.
- ▶ Press button 3 or 5 to adjust the engine shut-off time.
 - ▷ The status symbol 1 flashes.
- ▶ Press the key 2 to confirm the engine shutdown time.
- ▶ Press the button 4 to activate/deactivate *automatic engine shut down*.
 - ▷ The status symbol 1 flashes.
- ▶ Press the key 2 to confirm the *automatic engine shut down*.
 - ▷ If *automatic engine shut down* is activated: the button 4 is green. The *automatic engine shut down* symbol appears on the start page.

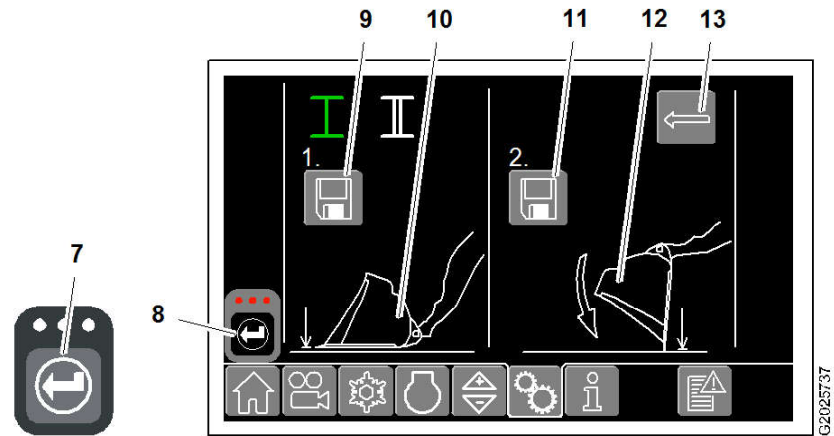

Fig. 181: Working attachment calibration

- | | | | |
|----|-----------------------------------------------|----|----------------------------------------------------|
| 7 | Confirmation key | 11 | Save calibration button |
| 8 | Confirmation prompt symbol | 12 | Figure: Working attachment perpendicular to ground |
| 9 | Save calibration button | 13 | Back button |
| 10 | Figure: Working attachment parallel to ground | | |

Calibrating the working attachment parallel to the ground:

- ▶ Place the working attachment flat on the ground, see Figure 10.
 - ▷ The button 9 lights up green.
- ▶ Press button 9.
 - ▷ Symbol 8 flashes.
- ▶ Press key 7.
 - ▷ Calibration is saved.

Calibrating the working attachment perpendicular to the ground:

- ▶ Place the working attachment perpendicular with the tip of the attachment on the ground, see Figure 12.
 - ▷ The button 11 lights up green.
- ▶ Press button 11.
 - ▷ Symbol 8 flashes.
- ▶ Press key 7.
 - ▷ Calibration is saved.
 - ▷ The working attachment calibration is completed.

Adjusting ride control

This equipment is optional.

The position monitor on the lift arms means that ride control can be activated in different modes.

- Ride control activated according to speed (default setting)
- Ride control activated with working attachment tilted in
- Ride control activated in loading position
- Ride control activated according to speed, with working attachment tilted in or in loading position

Make sure that following requirements are met:

- Ride control is activated on control unit.

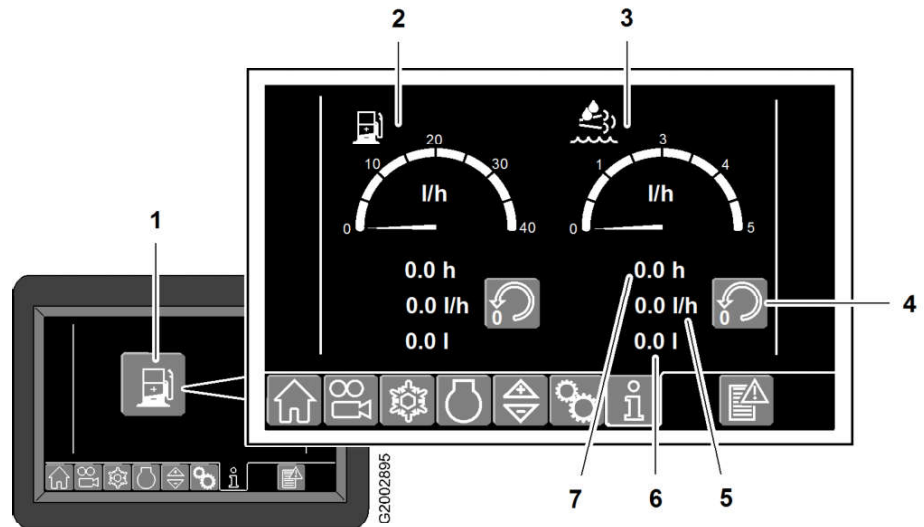

Fig. 198: Fuel consumption indicator

- | | |
|----------------------------------------------|--------------------------------------------------------|
| 1 Fuel consumption indicator button | 5 Fuel consumption litres per operating hour indicator |
| 2 Diesel engine fuel consumption indicator | 6 Fuel consumption litres indicator |
| 3 Diesel exhaust fluid consumption indicator | 7 Operating hours indicator |
| 4 Reset values button | |

► Call up the display screen using button 1.

If you want to reset a value to "0.0":

► Press button 4.

Tachometer

This equipment is optional.

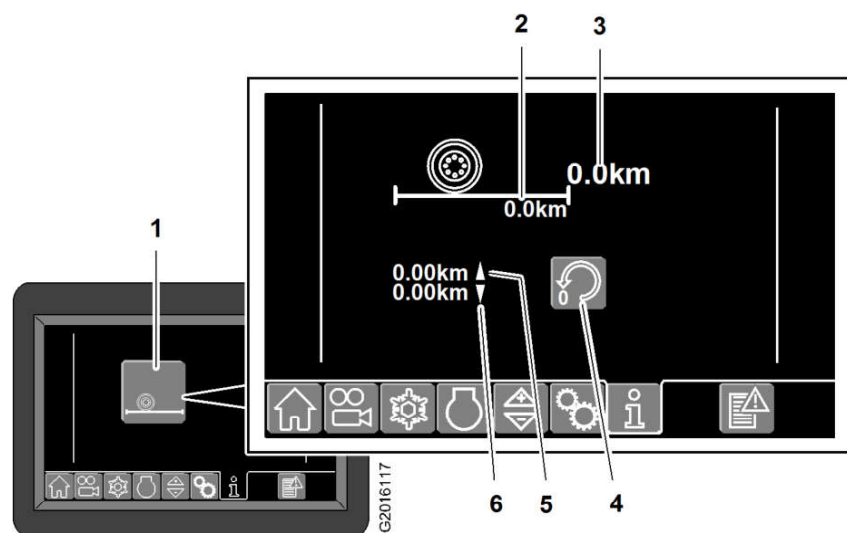

Fig. 199: Tachometer

- | | |
|---------------------|---------------------------------|
| 1 Tachometer button | 4 Reset daily tachometer button |
|---------------------|---------------------------------|

[See next page for continuation of the image legend](#)

**Note**

Quick coupler is activated.

Automatic return 3rd function is deactivated!

Deactivate automatic return 3rd function:

- ▶ Press button 2.
 - ▷ Symbol 1 flashes.
- ▶ Press key 3.
 - ▷ Button 2 turns white.

Calling up the setting for the working attachment

Fig. 219: Calling up the setting for the working attachment

- | | | | |
|---|-----------------------------|---|-----------------------------|
| 1 | Confirmation prompt symbol | 3 | Working attachment 2 button |
| 2 | Working attachment 1 button | 4 | Confirmation key |

- ▶ Press button 2 or 3.
 - ▷ Symbol 1 flashes.
- ▶ Press key 4.
 - ▷ The selected button is shown in green.
 - ▷ The values currently set for working attachment 1 and working attachment 2 are displayed.

3.2.24 Windscreen washer system

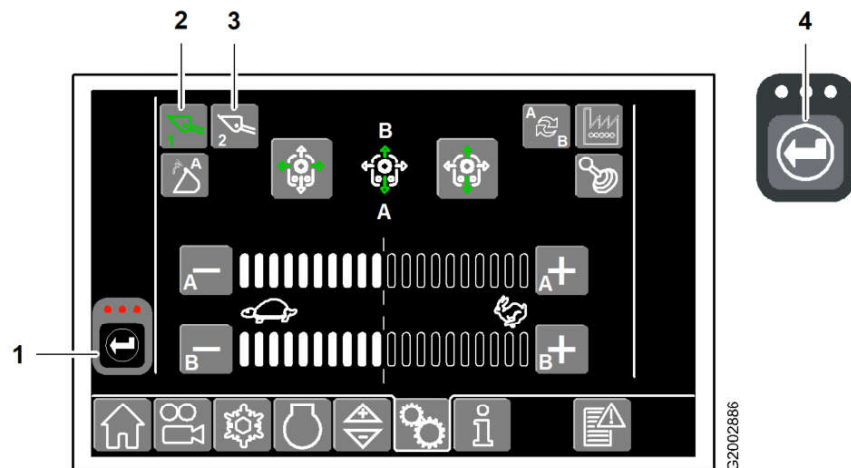
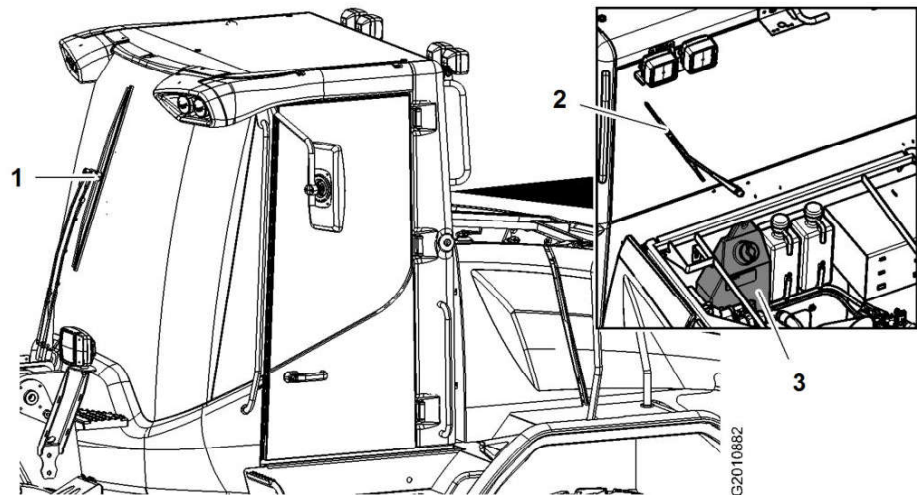

Fig. 251: Windscreen washer system

- | | | | |
|---|--------------------------------|---|-----------------------------------|
| 1 | Front windscreen washer system | 3 | Windscreen washer fluid reservoir |
| 2 | Rear windscreen washer system | | |

The machine has an electric windscreen washer system for the front and rear windshields.

The windscreen washer system consists of:

- Windscreen wipers
- Windscreen washer fluid reservoir with pump
- Outlet nozzles for washer fluid

Operating the windscreen washer system

Make sure that the following requirements are fulfilled: .

- The electrical system of the machine is switched on.

Front windscreen washer system

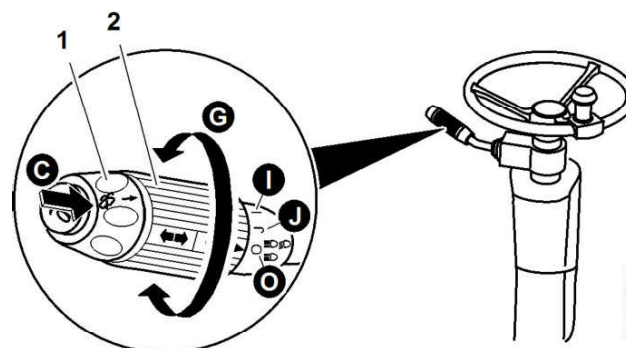

Fig. 252: Using the front windscreen washer system

- | | | | |
|---|--------|---|------------------------------------|
| 1 | Button | C | Windscreen washer fluid activation |
| 2 | Knob | G | Windscreen wiper activation |

To wipe the front windscreen:

CLICK HERE TO **DOWNLOAD** THE COMPLETE MANUAL

- Thank you very much for reading the preview of the manual.
- You can download the complete manual from: www.heydownloads.com by clicking the link below



- Please note: If there is no response to CLICKING the link, please download this PDF first and then click on it.

CLICK HERE TO **DOWNLOAD** THE COMPLETE MANUAL

Checking connection status

The following functions can be checked on the display:

- GSM reception quality.
- Cable connection between the central control unit and radio module LiTU.
- Availability of GPS data.

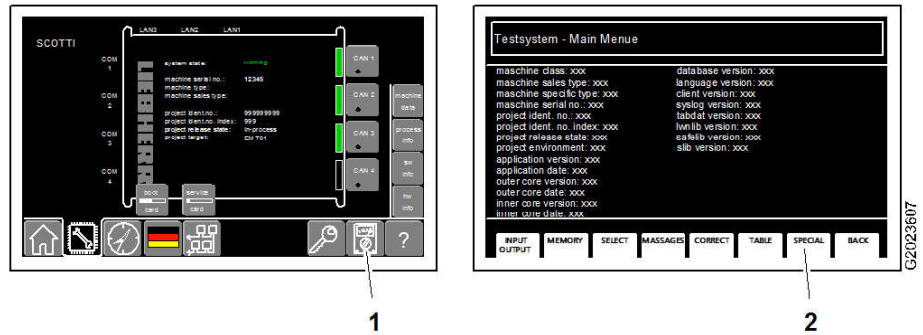

Fig. 264: Checking connection status

1 Testsys button

- ▶ Switch on the ignition.
- ▶ Press the button 1.
 - ▷ Terminal Modus screen is opened.
- ▶ Press the button 2.
 - ▷ Next screen is opened.

2 Special button

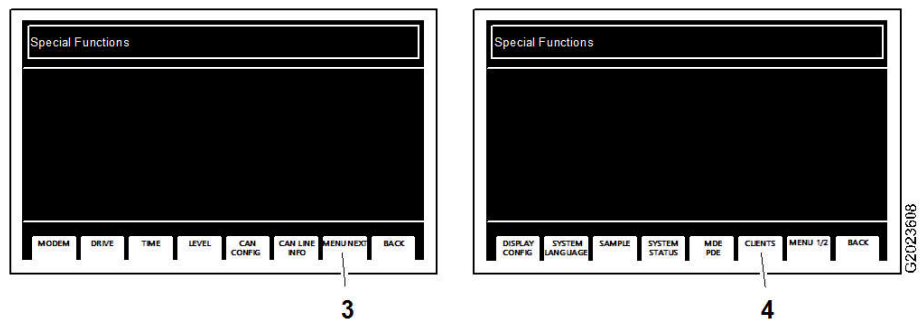

Fig. 265: Checking connection status

3 Menu Next button

- ▶ Press the button 3.
 - ▷ Next screen is opened.
- ▶ Press the button 4.
 - ▷ Next screen is opened.

4 Clients button

Activation with the machine at a standstill:

- ▶ Press key 1.
 - ▷ The LEDs light up.
 - ▷ The "Vmax" indicator appears in the display.
 - ▷ The speed restriction of the machine is activated.
 - ▷ When the accelerator pedal is fully depressed, the machine moves at a minimum speed of roughly 2 km/h (1 mph).

Activation with the machine moving:

- ▶ Drive at the required travel speed.
- ▶ Press key 1.
 - ▷ The LEDs light up.
 - ▷ The "Vmax" indicator appears in the display.
 - ▷ The speed restriction of the machine is activated.
 - ▷ The machine travels at the set speed when the accelerator pedal is fully depressed.

To switch off Vmax (speed restriction):

- ▶ Press the button 1 again or change the travel range.
 - ▷ The LEDs go out.

Driving with ride control

This equipment is optional.

If you travel long distances without ride control you may experience vibrations while driving.

The ride control system improves driving comfort by reducing the vibrations of the vehicle.

**DANGER**

Ride control deactivates pipe break protection!
Fatal injury.

- ▶ When performing lifting work which requires pipe break protection, deactivate ride control.

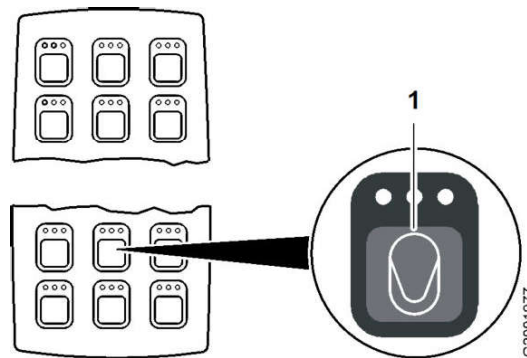

Fig. 276: Activating ride control

1 Ride control key

- ▶ To activate ride control: press the key 1.
 - ▷ Ride control is activated and is switched on automatically according to the current operating conditions.
- ▶ To deactivate ride control: press the key 1 again.

- ▶ Move the control lever 1 in direction D1.
 - ▷ The bucket is tilted out.

Moving the lift arms and the bucket simultaneously

The lift arms and bucket can be moved simultaneously by moving the control lever diagonally.



WARNING

Persons in the danger area!
Risk of injury.

- ▶ Make sure there is nobody in the danger area.

Raising the lift arms while tilting the bucket in or out

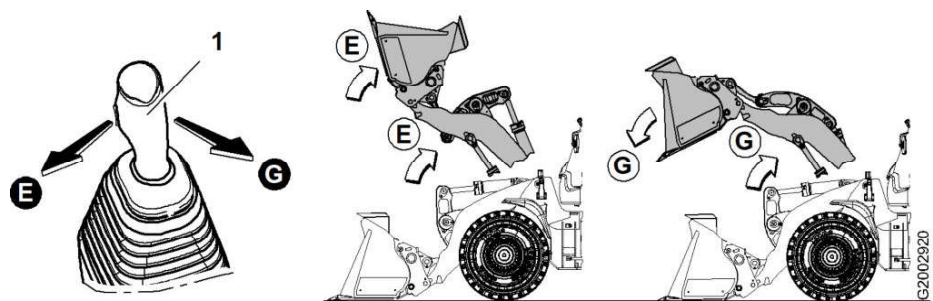

Fig. 290: Raising the lift arms while tilting the bucket in or out

1 Control lever

To raise the lift arms while tilting the bucket in:

- ▶ Move the control lever in direction E.
 - ▷ The lift arms are raised while the bucket is tilted in.

To raise the lift arms while tilting the bucket out:

- ▶ Move the control lever in direction G.
 - ▷ The lift arms are raised while the bucket is tilted out.

Lowering the lift arms while tilting the bucket in or out

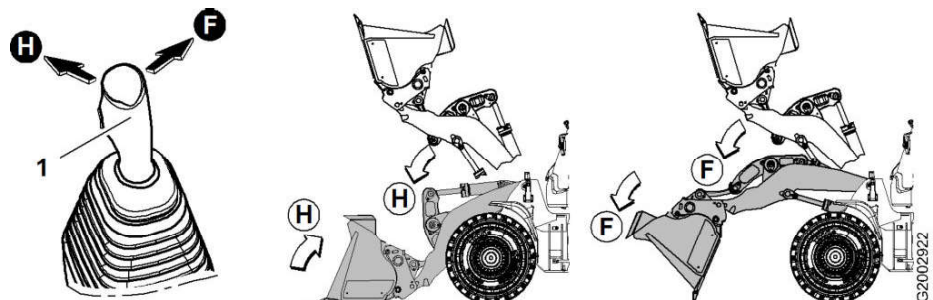

Fig. 291: Lowering the lift arms while tilting the bucket in or out

1 Control lever

To lower the lift arms while tilting the bucket in:

- ▶ Move the control lever in direction H.

Manual regeneration mode



Note

Regeneration mode for fire resistant and protected environments.

Do not leave the machine during manual regeneration.

During manual regeneration, only turn off the diesel engine in an emergency!

Switch/button position	Indicator in the display	Note
		<p><i>High exhaust temperature</i> symbol lights up at an exhaust temperature of > 300 °C (572 °F) at outlet of exhaust pipe.</p>

Tab. 60: Manual regeneration mode

NOTICE

Combustible deposits on the exhaust system!

Fire.

► Clean the exhaust system.

► Warm up the diesel engine (so that the coolant temperature is above 85 °C (185 °F)).

► Park the machine on level ground.

► Allow the diesel engine to run at lower idling speed.

► Engage parking brake.

► Press *regenerate diesel particulate filter* switch/button in position II for 3 seconds.

▷ Regeneration of the diesel particulate filter is activated.

▷ *High exhaust temperature* symbol lights up at an exhaust temperature of > 300 °C (572 °F) at outlet of exhaust pipe.

▷ Idling speed is increased without operator having to use accelerator pedal.

▷ Regeneration is completed when diesel engine returns to lower idling speed and *high exhaust temperature* symbol goes out.

▷ Regeneration can take up to 45 minutes.

If regeneration must be stopped in an emergency:

► Activate regeneration mode disabled.

3.3.8 Refuelling pump: Refuelling procedure

This equipment is optional.

The refuelling pump is in the right cab access.

Make sure that the following requirements are fulfilled:

The machine is in the operating position.

The working attachment is completely lowered.

- ▶ Move the switch **3** on the left armrest to position **0**.
- or
- Move the armrest **2** up by more than 45°.

**Note**

The left armrest is folded up.
The function of the travel direction switch on the joystick is taken over by the travel direction switch on the control lever.

- ▶ Select the travel direction on the control lever.

or

Turn the starting switch **1** to position **0**.

- ▷ The joystick steering function is deactivated.
- ▷ Deactivation has no effect on the function of the joystick steering travel direction switch.

Travel direction switch

Travel direction switches are fitted on the control lever and joystick of the wheel loader. The travel direction for the operation of the machine can be selected using either of the two switches, whereby only one of the switches is ever active at a time. Use the display navigation to select which of the two switches is used.

**Note**

Function settings!

- ▶ The setting remains stored after the ignition is switched off.
- ▶ Deactivating the *joystick steering* function does not affect the function or setting of the travel direction switch.

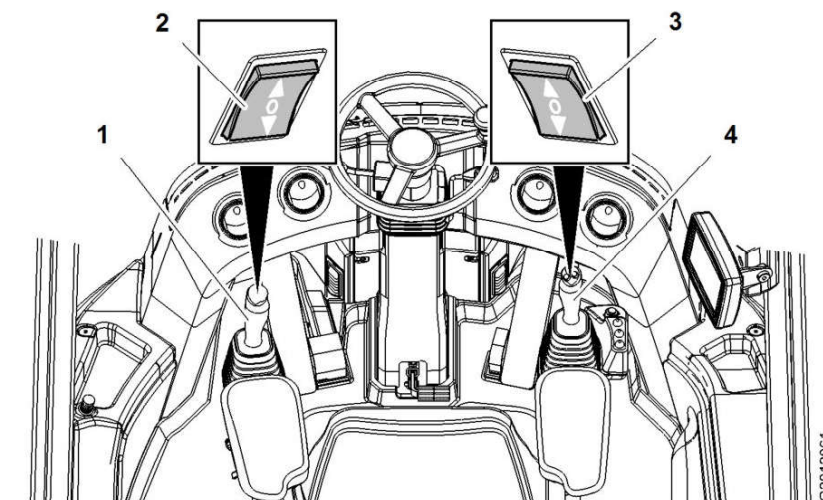
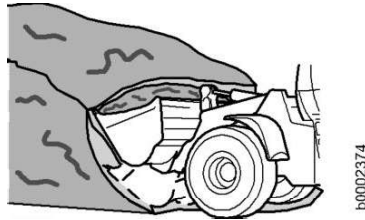

Fig. 321: Travel direction switch

- | | |
|---------------------------------------------------------------------------|-------------------------------------------------------------------------------------|
| <p>1 Joystick</p> <p>2 Joystick travel direction switch</p> | <p>3 Control lever travel direction switch</p> <p>4 Control lever</p> |
|---------------------------------------------------------------------------|-------------------------------------------------------------------------------------|



b0002374

Fig. 334: Removing material from a slope

- ▶ Start at the foot of the slope and work upwards.

Removing material from a wall

This is how to remove hard material.



b0002375

Fig. 335: Removing material from a wall

- ▶ Slightly tilt up the working attachment.
- ▶ Start removing material at the top and work downwards.



DANGER

Falling material!
Risk of fatal injury.

- ▶ Do not remove material from under overhangs.
- ▶ Remove overhangs first and then look out for slippage.

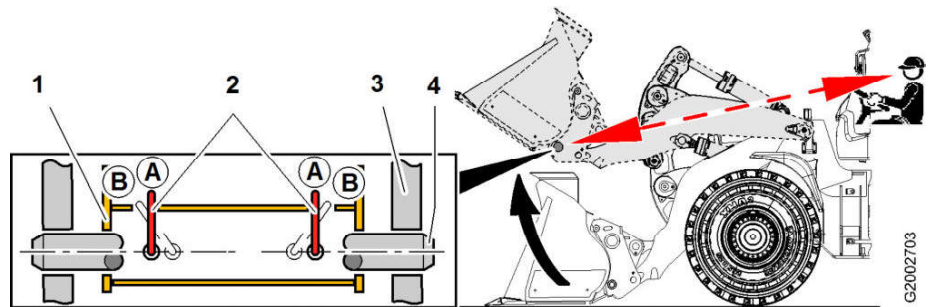

Fig. 347: Visual inspection

- | | | | |
|---|--------------------|---|-------------------|
| 1 | Quick coupler | 4 | Locking pin |
| 2 | Locking indicator | A | Locked position |
| 3 | Working attachment | B | Unlocked position |

- ▶ Move the lift arms until you can see the quick coupler from the cab.
- ▶ Make a visual inspection on both sides.
 - ▷ The lock indicator 2 should be in the locked position A.
 - ▷ The locking pins 4 must have retracted as far as the outer hole on the working attachment 3.

Mechanical check

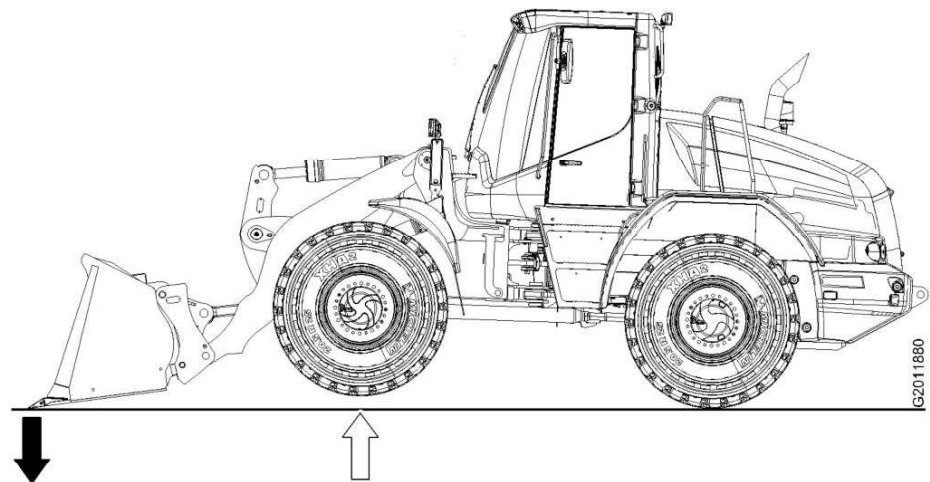

Fig. 348: Mechanical check

- ▶ Push the front edge of the bucket against the ground so that the front axle of the machine is slightly raised.
 - ▷ The bucket must remain firmly attached to the quick coupler.

Connecting the hydraulic lines

If the working attachment has its own hydraulic supply, the hydraulic lines must be connected.

Make sure that the following requirements are met:

- The working attachment is properly fitted to the quick coupler.
- You have checked that it is locked.
- The hydraulic system is depressurised.

- Towing with the diesel engine off

Towing with the diesel engine running

Keep the towing as short as possible and only do it on solid ground.

The following precautions must be taken before towing the machine:

1. Put the machine in the towing position.
2. Switch the travel pump to free circulation. ⁶⁵⁾
3. Disconnecting the proportional valve from the travel motor
4. Have towing ropes of sufficient strength ready.

Make sure that the following requirements are met:

- The brake system and steering are working.
- Sufficiently strong slinging gear and towing equipment is available.

Putting the machine in the towing position

Make sure that the following requirements are met:

- Machine is in maintenance position 2.

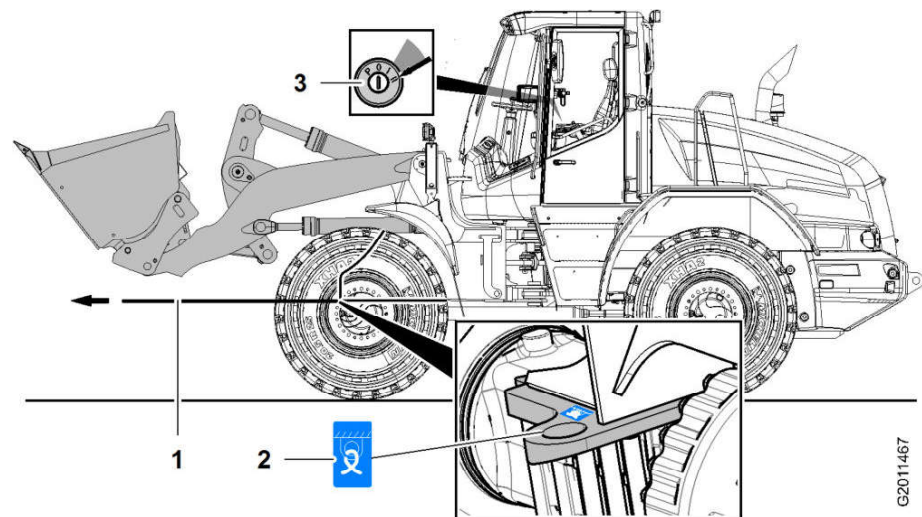

Fig. 357: Towing with the diesel engine running

- | | | | |
|---|----------------|---|-----------------|
| 1 | Slinging gear | 3 | Starting switch |
| 2 | Lashing points | | |

- ▶ Fasten the slinging gear 1 to the lashing points 2 on both sides.
- ▶ Switch on the battery main switch.
- ▶ Release the articulation lock.
- ▶ Start the diesel engine with starting switch 3.
- ▶ Raise the lift arms above the lashing points 2.
- ▶ Tilt in the bucket as far as it will go.
- ▶ Start the diesel engine with the starting switch 3.

⁶⁵⁾ When the travel pump is not in free circulation mode, the machine may not be towed further than 200m.

4 Malfunctions

Warning and error messages:

- Various faults are indicated by corresponding symbols or service codes in the display.
- Some warning messages are accompanied by audible signals.

Finding and eliminating faults:

- Analyse the cause of the fault and correct it immediately.
- Before calling in Liebherr customer service, make sure you know the **type number** and **serial number** of the affected machine.
- Never perform any work for which you have not been trained or instructed.



Note

Unable to eliminate the fault!

- ▶ Contact Liebherr customer service.
-

4.1 Servicecodes

4.1.1 Service code indicator in the display

All service codes must be shown on the display with cause and remedy.

(For more information see: [Menu: service codes, page 132](#))







Note

If the display fails!

- ▶ Contact Liebherr customer service.
-

Fuse	Value	Unit	Designation/function
F30	10	A	Angle sensor
F31	10	A	Rear windscreen washer system
F31A	10	A	Front working headlights
F31B	10	A	Front working headlights
F32	3	A	Diesel pre-heating
F32A	10	A	Rear working headlights
F32B	10	A	Rear working headlights
F33	5	A	Brake light
F34	5	A	Immobilizer
F35	5	A	Multi-lever control
F36	10	A	Pilot control sensor
F37	10	A	Main keypad
F38	15	A	Rear window heater
F39	10	A	Mirror adjustment
F40	10	A	Hazard light, terminal 15
F41	15	A	Driving lights
F42	10	A	Radio 12 V terminal 30
F43	10	A	Radio 12 V terminal 15
F44	10	A	Interior lighting
F45	10	A	Spare
F46	10	A	Spare
F47	10	A	Flashing beacon
F48	10	A	Immobilizer
F49	10	A	Master / diagnostics
F50	5	A	Auxiliary heater preset clock
F51	10	A	Working basket
F52	10	A	Spare
F53	7.5	A	Left high beam
F54	7.5	A	Left-hand driving light
F55	5	A	Left marker lights
F56	5	A	Right marker lights
F57	25	A	Engine power supply
F58	25	A	Engine power supply
F59	25	A	Engine power supply
F60	10	A	Emergency steering
F61	10	A	Spare
F62	15	A	Heating and air conditioning
F63	20	A	Auxiliary heater

5.2.2 Recommended operating fluids

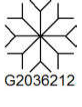
Designation	Recommended operating fluid	Symbol	Quantity
Fuel tank Fuel reserve, approx.	Conventional diesel fuel with a maximum sulphur content of 0.0015 % (0 %)	 G2036211	205 l 54.15 gal 30 l 7.93 gal
Diesel exhaust fluid tank	AdBlue® in Europe DEF (Diesel exhaust fluid) in the USA	 b0002485	20 l 5.28 gal
Engine cooling system total capacity	Liebherr Antifreeze OS Mix	 06sy04ab	31 l 8.19 gal
Windscreen washer system	Standard windscreen washer fluid or denatured alcohol	 b0000055	3.5 l 3.7 liq qt
Air conditioning unit refrigerant	R134a CO ₂ equivalent	 G2036212	1.18 ^{+0.02} kg 2.60 ^{+0.04} lb 1.69 t 3,726 lb
Refrigerant oil for air conditioning compressor	ZXL 100 PG (PAG Oil)		200 cm ³ 12 in ³

Tab. 72: Recommended fuel and operating fluid

5.2.3 Lubrication chart

The lubrication chart provides an overview of the location of the maintenance points on the machine and of the maintenance intervals.

Information on:

- Performance of maintenance tasks (For more information see: [5.1 Maintenance and inspection schedule, page 255](#))
- Lubricants and fuels (For more information see: [5.3 Lubricants and fuels, page 264](#))
- Filling quantities (For more information see: [5.2 Filling quantities and lubrication chart, page 260](#))

5.4 Safety precautions

Observe the relevant **safety instructions** when carrying out all maintenance, inspection or repair work. Local health and safety regulations, accident prevention regulations and national laws must be observed.

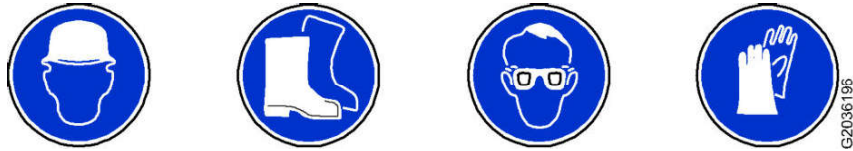

Fig. 409: Safety precautions

Make sure that following requirements are met:

- Suitable protective equipment is present.
- The driver and maintenance staff are in visual contact.

Protective equipment must be worn for some tasks:

- Hard hat
- Safety footwear
- Safety glasses
- Protective gloves



WARNING

Persons in the danger area!
Risk of injury.

- ▶ Make sure there is nobody in the danger area.
-
- ▶ Wear appropriate working clothing.
 - ▶ Always maintain visual contact with the maintenance staff.

- ▶ Document the damage and observe whether the condition deteriorates.

If the condition deteriorates:

- ▶ Have the hydraulic lines replaced immediately by Liebherr customer service.

If the condition does not deteriorate:

- ▶ Have the hydraulic line replaced within the next 250 operating hours by Liebherr customer service.

Severe damage to the hydraulic lines



DANGER

Hydraulic oil discharged under high pressure!
Fatal injury.

- ▶ Do not operate the machine.

Visible oil leak

Oil leaks from the hydraulic line. Leaking oil is classified as severe damage.

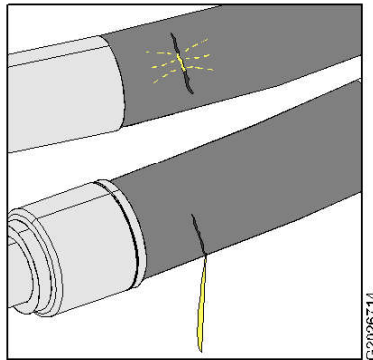

Fig. 421: Visible oil leak

- ▶ Take the machine out of operation and secure it against restarting.
- ▶ Have the damaged hydraulic line replaced immediately by Liebherr customer service.

Damaged or corroded steel fabric

Damaged or corroded steel fabric is classified as severe damage.

Cleaning the service cover

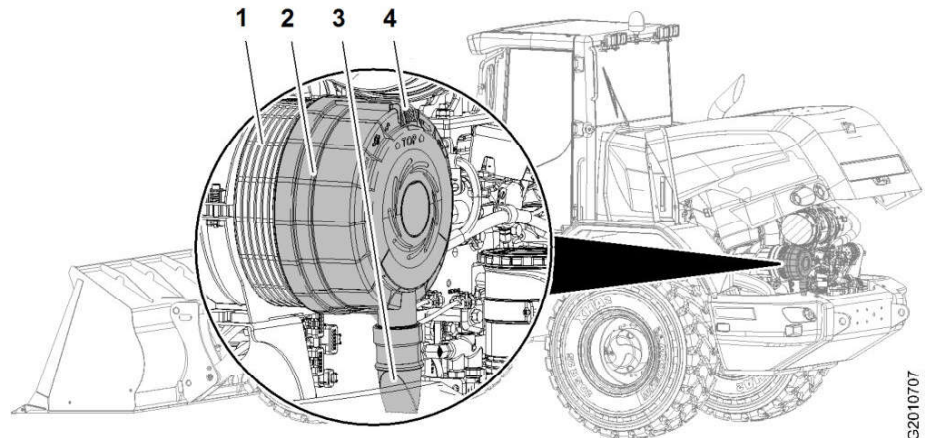

G2010707

Fig. 429: Air filter system: Clean the service cover and dust discharge valve.

- | | | | |
|---|----------------|---|----------------------|
| 1 | Filter housing | 3 | Dust discharge valve |
| 2 | Service cover | 4 | Retaining clip |

- ▶ Release the safety clamp 4 on the service cover 2.
- ▶ Turn the service cover 2 anticlockwise and take it off.
- ▶ Clean the service cover 2 and place it back onto the filter housing 1.
 - ▷ The dust discharge valve 3 must face down.
- ▶ Turn the service cover 2 clockwise until it is locked.
- ▶ Close the safety clamp 4.

Cleaning the dust discharge valve



Note

When using the machine in dusty conditions:

- ▶ Check and empty the dust discharge valve more often.

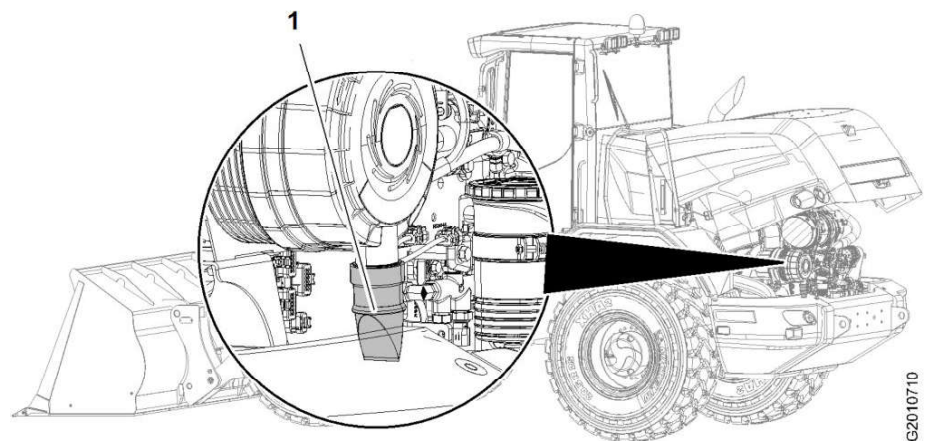

G2010710

Fig. 430: Cleaning the dust discharge valve

- | | |
|---|----------------------|
| 1 | Dust discharge valve |
|---|----------------------|

5.10 Steering system

5.10.1 Steering: Checking the function

Make sure that the following requirements are fulfilled:

- The working attachment is in the transport position.
- Articulation lock is released.
- There is enough space to test the steering.



WARNING

Persons in the danger area!
Risk of injury.

- ▶ Make sure there is nobody in the danger area.

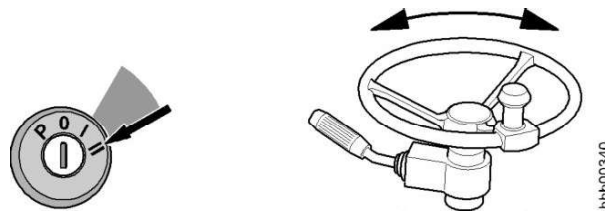

Fig. 441: Steering: Checking the function

- ▶ Start the engine.
- ▶ Without moving the machine, turn the steering in both directions and check that it is functioning properly.

5.10.2 Steering cylinders: Lubricating the bearings

Make sure that the following requirements are fulfilled:

- The machine is in maintenance position 1.
- The lubrication point has been cleaned.

- Machine is cleaned.
- Suitable protective equipment is used.

Make sure that the following special tools are ready for installation of the undercut blade:

- Torque wrench with corresponding measurement range.
- Loctite 241



WARNING

Beware of falling components!
Injury.

- ▶ Secure teeth or undercut blade from detaching.

Checking teeth or undercut blade for wear

- ▶ Check teeth or undercut blade for cracks, excessive wear and for broken-out parts.

If teeth or undercut blades are worn:

- ▶ [\(For more information see: Replace teeth with Z system, page 311\)](#)
- ▶ [\(For more information see: Changing the undercut blade, page 312\)](#)

Replace teeth with Z system

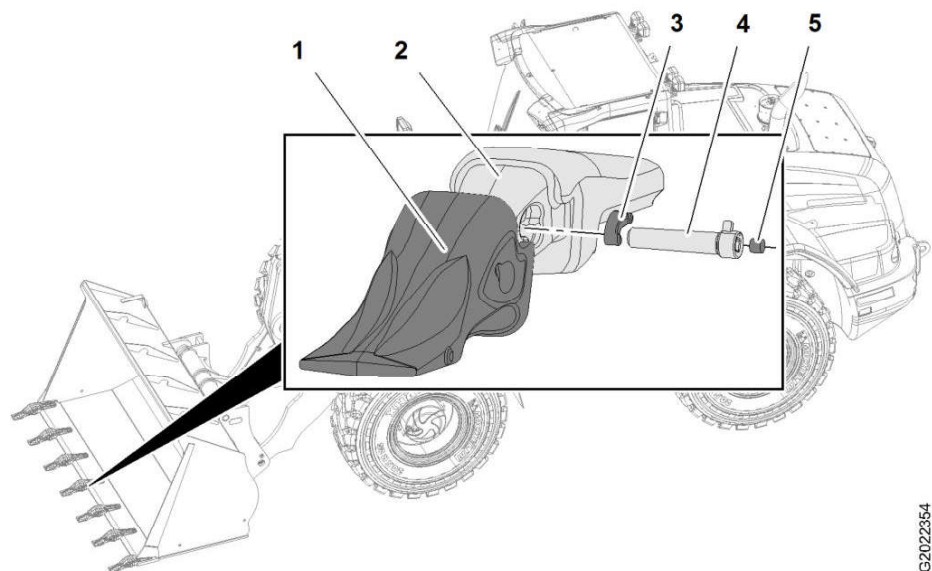

Fig. 450: Replace teeth with Z system

- | | | | |
|---|---------------|---|---------------|
| 1 | Tooth | 4 | Retaining pin |
| 2 | Tooth adapter | 5 | Plug |
| 3 | Bar | | |

Tooth removal

- ▶ Remove plug 5.
- ▶ Turn retaining pin 4 with square spanner about 30° in direction tooth 1.
 - ▷ Nose of the retaining pin 4 slips out of bar.
- ▶ Knock out retaining pin 4 with hammer and mandrel.

CLICK HERE TO **DOWNLOAD** THE COMPLETE MANUAL

- Thank you very much for reading the preview of the manual.
- You can download the complete manual from: www.heydownloads.com by clicking the link below



- Please note: If there is no response to CLICKING the link, please download this PDF first and then click on it.

CLICK HERE TO **DOWNLOAD** THE COMPLETE MANUAL