

Grove GMK 4100

Operating manual Part 1 – Driving

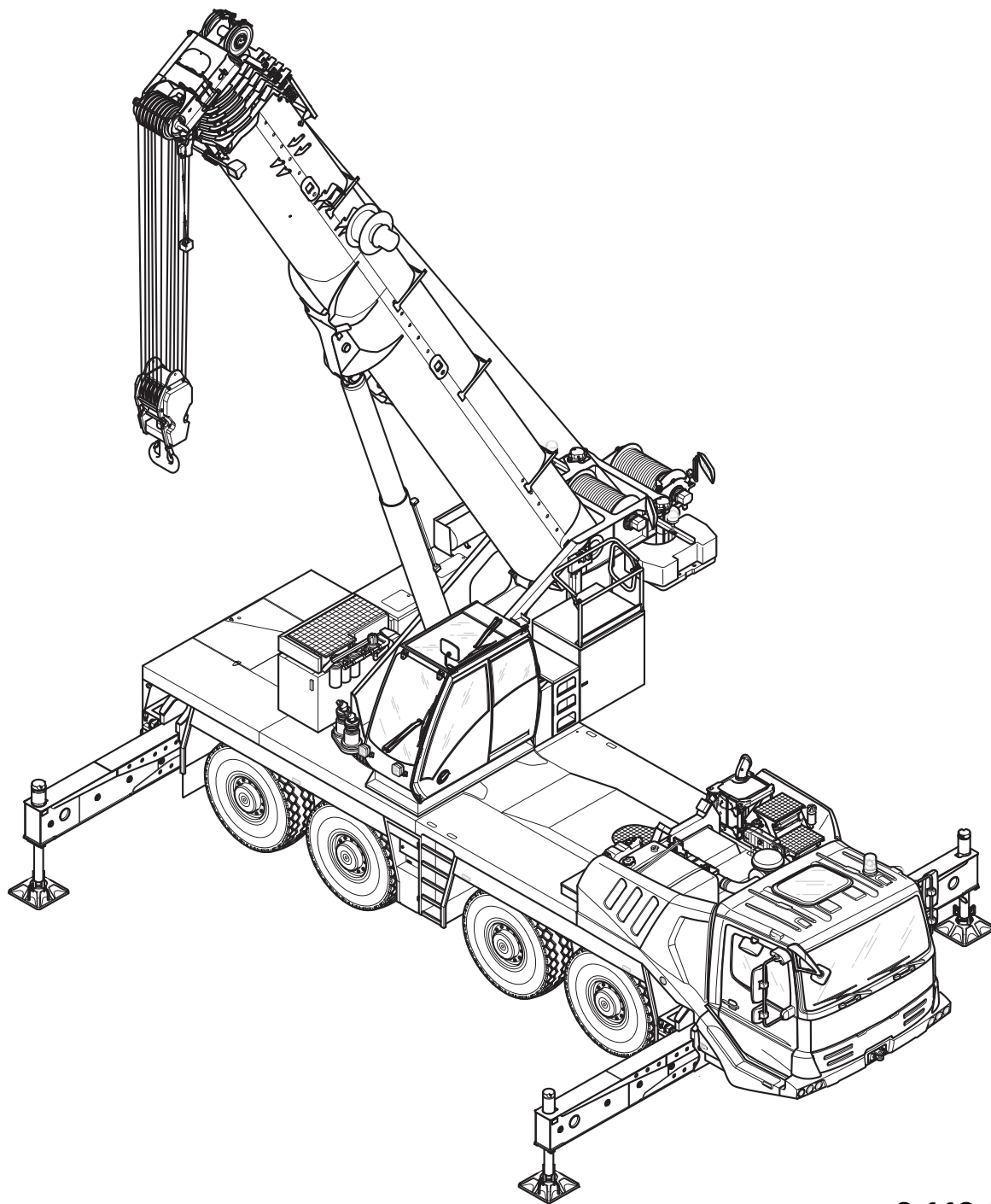

3 113 126 en
15.02.2015

Grove

Manitowoc

National Crane

Potain

Manitowoc

CLICK HERE TO **DOWNLOAD** THE COMPLETE MANUAL

- Thank you very much for reading the preview of the manual.
- You can download the complete manual from: www.heydownloads.com by clicking the link below



- Please note: If there is no response to CLICKING the link, please download this PDF first and then click on it.

CLICK HERE TO **DOWNLOAD** THE COMPLETE MANUAL

1.2

Branch offices

1.2.1

Manitowoc Crane Care

If you need help or support with the operation on your truck crane, you can contact our branches at the following addresses **Manitowoc Crane Care**:

<https://www.manitowoccranes.com>

1.2.2

Dealer list

Visit the following address for a global list of dealers:

<https://www.manitowoccranes.com>

1.3

Warranty specifications

Please see the separately enclosed warranty certificate for information.

1.5.4

Carrier

Engine

Mercedes-Benz:	OM 460 LA	
Engine emission:	EUROMOT 3A \ EPA \ CARB (off road)	EUROMOT 3B ¹⁾ \ EPA \ CARB (off road)
Power:	295 kW (400 PS) or 335 kW (456 PS) ¹⁾ at 1800 rpm (80/1269 - 89/491 EEC – including all modifica- tions)	315 kW (428 PS) at 1800 rpm (80/1269 - 89/491 EEC – including all modifica- tions)
DEF tank ¹⁾ :	–	approx. 40 l
Fuel tank		
– Standard tank:	On the carrier – approx. 400 l	

¹⁾ Additional equipment



1.7

Notes on the operating instructions

These operating instructions are not a training manual for prospective crane operators! All descriptions have been written explicitly for crane operators who have been trained to operate truck cranes.

These operating instructions are designed as a reference manual. They provide either a brief or a detailed explanation to the crane driver, based on his prior knowledge, of the individual operating steps and procedures.

1.7.1

What do the symbols used mean?

The following designations and symbols are used in the operating instructions and in the maintenance manual to highlight particularly important information.

The vertical line to the left of the hazards and warnings indicates that: This text, regardless of its length, relates to the warning symbol.



This symbol indicates hazards related to the described operation and which may cause personal injury during execution. The type of danger (e.g. danger to life, risk of injury or risk of crushing) usually precedes the warning.



This symbol indicates dangers which represent a hazard to objects, e.g. damage to the truck crane or other parts which are located within the working range.

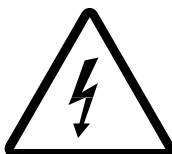

This symbol warns you about situations where there is a danger of electric shock.



This symbol is to remind you that you are working with substances which pose a risk to the environment. Take particular care. For further information on handling substances that are harmful to the environment;

➡ *Maintenance manual*, chapter on *Safety and environmental protection*.



1.9

Training – Information

For the EMEA (Europe, Middle East, Africa) area, **Manitowoc Crane Group Germany GmbH** offers comprehensive training for crane types GMK and GTK.

Our training centre is located in a maritime environment, on Germany's North Sea coast in Wilhelmshaven. It is there where we train our qualified service personnel and provide you, as the customer (or sales and marketing employee), with a training programme specific to your target group.

Knowledge of crane technology, components and systems used, crane functions and measures for the prevention of accidents that is acquired from the training is tailored to each target group and designed for safe, time-saving operation of your crane or else consolidates your specialist know-how of sales, marketing and service.

Our range of training programmes includes more than 20 different courses. Take advantage of our services:

- Training for prevention of accidents and crane operation.
- Crane technology training.
- Training tailored to your needs and level of experience, for different levels of difficulty from beginner to specialist.
- Theoretical and practical training, on simulators and on (your) crane.
- Training in the vicinity of GMK and GTK production.
- Training courses with the duration required by the individual; from two days to several weeks.
- Our coaches can also visit you to provide you with training on your own crane.

Have us design a suitable training programme for you today. We would be pleased to advise you! Your **Training Center Wilhelmshaven**.

Our contact information and an overview of our current training courses can be found online at:

<https://www.manitowoccranes.com>

2.3

Personnel qualifications

These operating instructions are not a training manual for prospective crane operators!

All descriptions are written explicitly for crane operators who have been trained to operate truck cranes.

Personnel in training may only operate the truck crane under supervision.

Only reliable personnel may operate or carry out work on the truck crane.

As a crane operator you must fulfil a number of requirements:

- You must possess a driving license for this type of vehicle that is valid in the country in which you are working.
- You must have general knowledge about working with cranes and the qualifications required in the country in which you are working.
- You must be familiar with and understand the operating instructions.
- You must be familiar with and have understood the accident prevention regulations.
- You must fulfil all physical and mental requirements for truck crane operation, e.g. perfect sight and hearing and the ability to react quickly.

Please also refer to the section in the *Safety manual* titled *You as driver and crane operator*.

Only experienced personnel who are familiar with the valid accident prevention regulations are authorised to sling loads and instruct the crane operator.

Your responsibilities as a crane operator (including those concerning traffic requirements) must be clearly defined. You must be in a position to refuse instructions given to you by third parties that violate the safety regulations.

Only trained personnel with special knowledge and experience in the fields of hydraulics, pneumatics and electrical equipment and electronics may carry out maintenance work on the truck crane.

Manitowoc Crane Group Germany GmbH conducts general and type-specific crane operator courses and technical courses.

3

Operating elements for driving

All operating elements for crane operation are described in chapter 9.

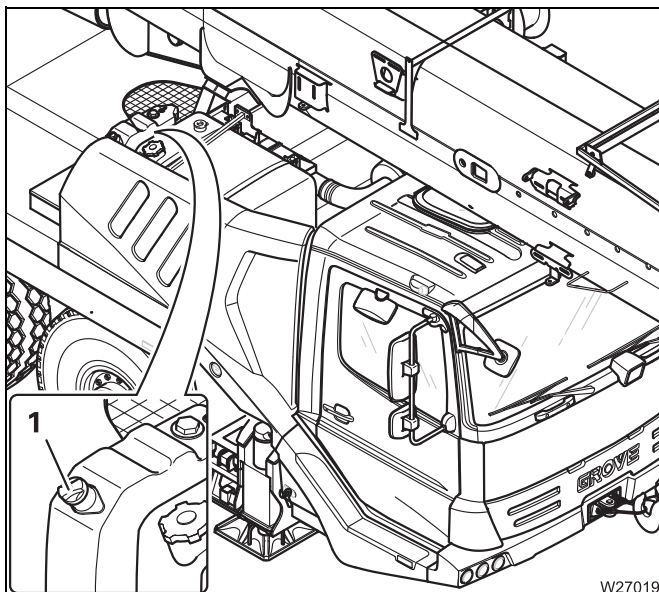

If the tank (1) is present, then the truck crane is equipped with the additional equipment *DEF system*¹⁾.

The *DEF system* is only present on truck cranes that comply with the exhaust emissions in TIER4i or Euromot 3B.

¹⁾ **DEF (Diesel Exhaust Fluid)**, consumable for after-treatment of exhaust gases, e.g. *AdBlue*.

For *AdBlue*, there are registered trademarks of Kruse GmbH & Co KG, BASF SE and the German Association of the Automotive Industry.

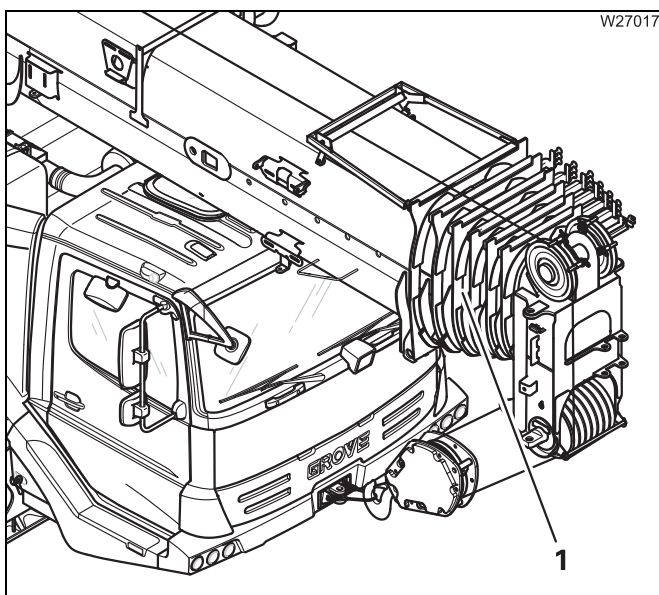

This operating manual contains illustrations of the GMK 4100L with six telescopic sections.

The GMK 4100 has five telescopic sections (1). The illustrations have only been altered where relevant for the operation.

1	Indicator lamp for turn signal indicator	➡ p. 3 - 56
2	Display, driving mode	➡ p. 3 - 12
3	Speedometer	➡ p. 3 - 60
4	Tachometer	➡ p. 3 - 39
5	DEF level display ¹⁾	➡ p. 4 - 18
6	Fuel level display	➡ p. 4 - 18
7	Display – supply pressure in brake circuits	➡ p. 3 - 51
8	Kilometre counter	➡ p. 3 - 60
9	STOP warning	➡ p. 3 - 39
10	Temperature of the coolant/outside air display	➡ p. 4 - 19
10.1	Switch over the display	➡ p. 4 - 19
11	DEF warning ¹⁾	➡ p. 3 - 40
12	Torque reduction indicator lamp ¹⁾	➡ p. 3 - 40
13	Prompt to brake	➡ p. 3 - 47
14	ABS warning	➡ p. 3 - 51
15	Trailer ABS warning lamp ¹⁾	➡ p. 3 - 51
16	DEF system malfunction ¹⁾	➡ p. 3 - 41
17	Headlight – full beam indicator lamp	➡ p. 3 - 56
18	Parking brake indicator lamp	➡ p. 3 - 52
19	Additional brake indicator lamp	➡ p. 3 - 53
20	Flame start system monitoring ¹⁾	➡ p. 3 - 39
21	Show journey data/reset	➡ p. 3 - 63
22	Instrument lighting dimmer	➡ p. 3 - 58
23	Instrument lighting brighter	➡ p. 3 - 58

¹⁾ Additional equipment

1 Transfer case for off-road gear on/off	▶▶▶▶ p. 3 - 48
Transfer case display	▶▶▶▶ p. 3 - 48
2 Displaying vehicle height ¹⁾	▶▶▶▶ p. 5 - 9
3 Suspension display	▶▶▶▶ p. 3 - 55
4 Level adjustment system submenu	▶▶▶▶ p. 3 - 22
5 Warning for steering circuit 1 and steering circuit 2	▶▶▶▶ p. 3 - 54
6 Transverse differential locks display	▶▶▶▶ p. 3 - 49
Transverse differential locks on/off	▶▶▶▶ p. 3 - 49
7 Longitudinal differential locks display	▶▶▶▶ p. 3 - 49
Longitudinal differential locks on/off	▶▶▶▶ p. 3 - 49
8 Settings submenu	▶▶▶▶ p. 3 - 23
9 Hydraulic oil temperature display	▶▶▶▶ p. 4 - 19
10 Steering locking status display	▶▶▶▶ p. 3 - 54
Separate steering on/off	▶▶▶▶ p. 3 - 54
11 Combined operation display off	▶▶▶▶ p. 3 - 39
12 Combined operation display on	▶▶▶▶ p. 3 - 39
Starting/turning off the engine	
13 Serial number/program version display	▶▶▶▶ p. 3 - 44
14 Warning display	▶▶▶▶ p. 3 - 44

¹⁾ Additional equipment

Auxiliary water heater

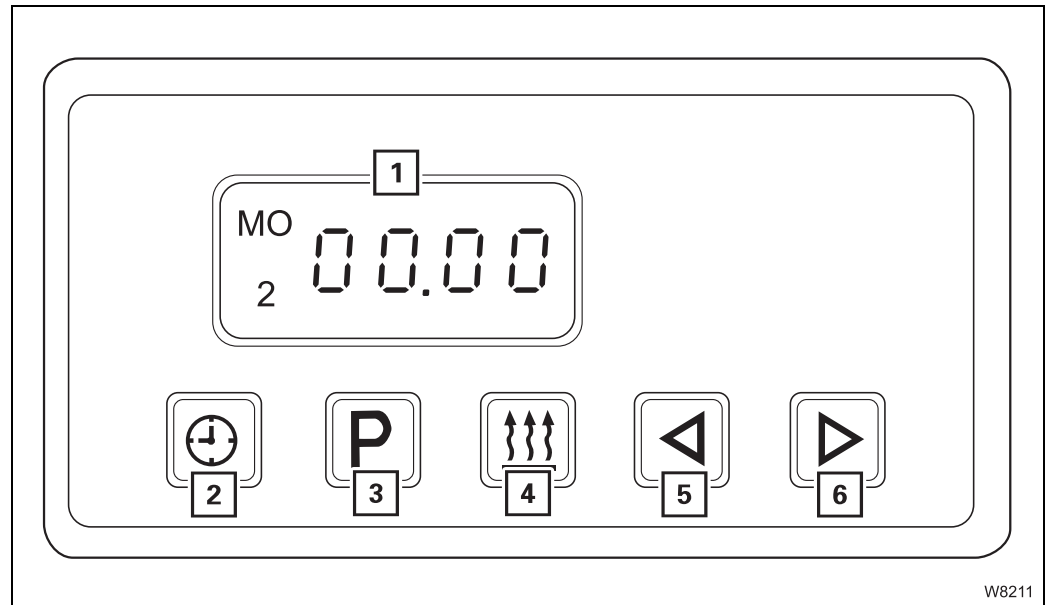

- | | |
|--------------------------------------|------------------|
| 1 Heating display | ▣▣▣▣▶ p. 5 - 98 |
| 2 Setting the day and time | ▣▣▣▣▶ p. 5 - 98 |
| 3 – Storing the heating start | ▣▣▣▣▶ p. 5 - 99 |
| – Switching heating start on/off | ▣▣▣▣▶ p. 5 - 100 |
| 4 – Switching on | ▣▣▣▣▶ p. 5 - 97 |
| – Switching off | ▣▣▣▣▶ p. 5 - 101 |
| 5 Input – | ▣▣▣▣▶ p. 5 - 98 |
| 6 Input + | ▣▣▣▣▶ p. 5 - 98 |

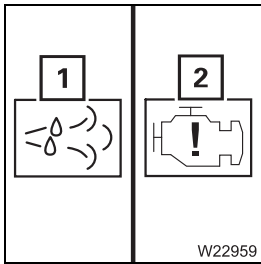

DEF system malfunction

1, 2 – Lamps:

➡ *Malfunctions on the DEF system, p. 7 - 25*

3.2.5

Electrical system

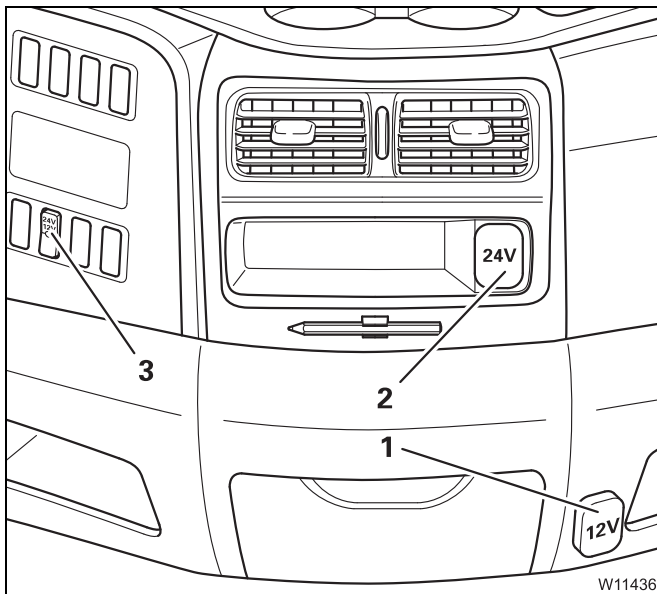

Sockets 12 V/24 V

- 1 Socket 12 V
- 2 Socket 24 V

Voltage on/off

- 3 – Top on – socket voltage on
- Bottom on – socket voltage off

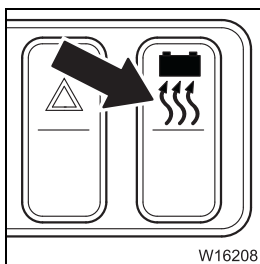

Battery heater on/off

- Up: Heating system on
- Down: Heating system off

Further information on operation; ➡ *Separate engine operating instructions.*

3.2.11

Brakes

Service brake

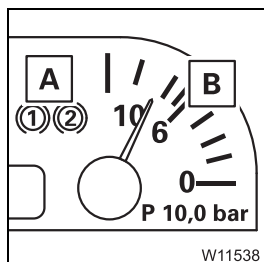

Display – supply pressure in brake circuits

- A** Brake circuit with low supply pressure – display 1 or 2
- B** Current supply pressure in the brake circuit displayed (**A**) in bar

Display on the *On-board computer display*;  *Supply pressure*, p. 5 - 24

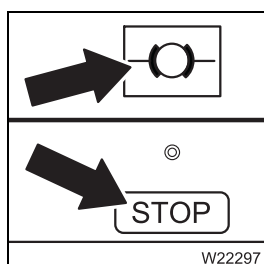

Warning – supply pressure in the brake circuit too low

- **On:** Supply pressure below approx. 5 bar
- **Off:** Supply pressure above 5.5 bar

 *Supply pressure*, p. 5 - 24

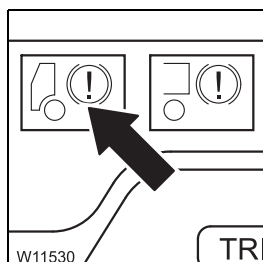

ABS warning

- **On:** Approx. 6 km/h not reached
or
ABS defective
- **Off:** Approx. 6 km/h exceeded, and ABS ready to function

 p. 5 - 42

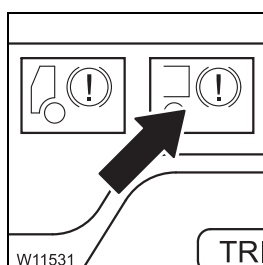

Trailer ABS warning lamp

- **On:** Approx. 6 km/h not reached
or
ABS trailer faulty
- **Off:** Approx. 6 km/h exceeded, and ABS trailer ready to function

 p. 5 - 42



3.2.17 Diagnostics

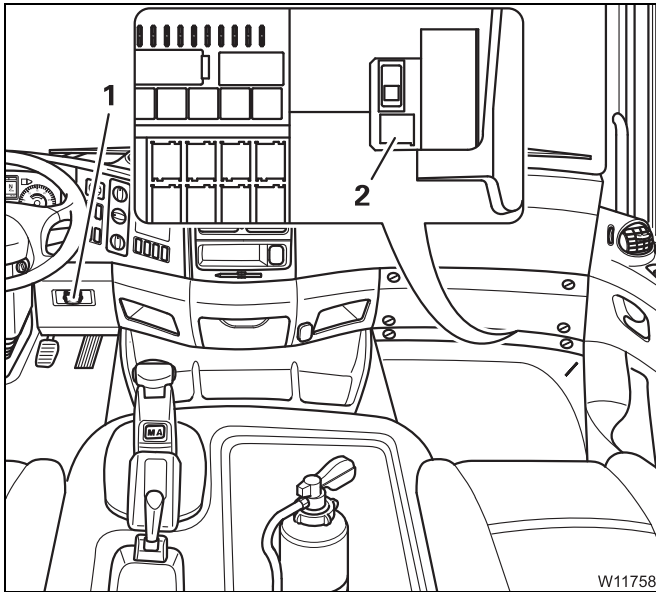

The diagnostics connections may only be operated by service staff from the engine transmission manufacturer, or by **Manitowoc Crane Care**.

- 1 Engine/transmission diagnostics
- 2 ECOS diagnostics

Displays/ submenu

Settings submenu

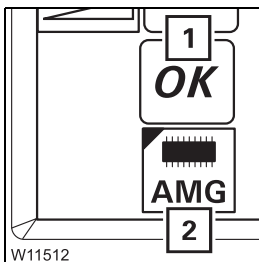

1 AMG diagnostics

OK, STOP or the service symbol (spanner) is displayed, depending on the severity of the error

2 Diagnostics submenu

If there is a malfunction, press button (2) once, read the values in the submenu and report to **Manitowoc Crane Care**.

Further displays are shown on the *Driving display*; *Diagnostics*, p. 5 - 26.

4

Starting/turning off the engine for driving

4.1

Starting the engine from the driver's cab

This section describes how to start the engine from within the driver's cab. You can also start the engine using the hand-held control, or from the crane cab; ■■■► *Starting the engine for driving for rigging work*, p. 12 - 25.

4.1.1

CHECKLIST: Starting the engine



This checklist is not a complete operating manual. There are accompanying operating instructions which are indicated by cross-references.

Observe the warnings and safety instructions specified here.

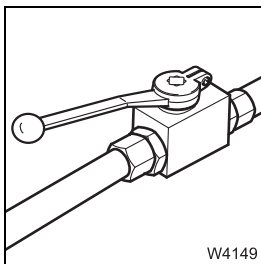

1. Check that the valves on the hydraulic tank are open; ■■■► p. 4 - 9.

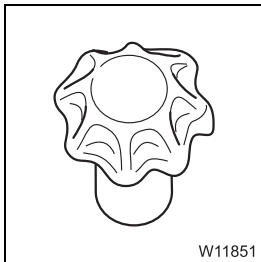

2. Check the coolant level of the engine; ■■■► *Maintenance manual*.

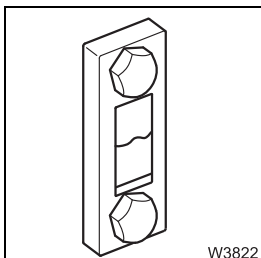

3. Check the oil level in the hydraulic system; ■■■► *Maintenance manual*.



4.1.7

Lamp test/equalisation of the switching states

Lamp test

After the ignition has been switched on, a lamp test is performed.

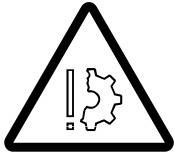

Risk of accidents due to faulty lamps

The lamps that are used to provide warnings and information during operation light up for control purposes whenever the ignition is switched on. Always perform the following lamp tests and immediately replace faulty lamps or have them replaced!

In this way, you will avoid accidents and damage that occur when malfunctions are not identified in time.

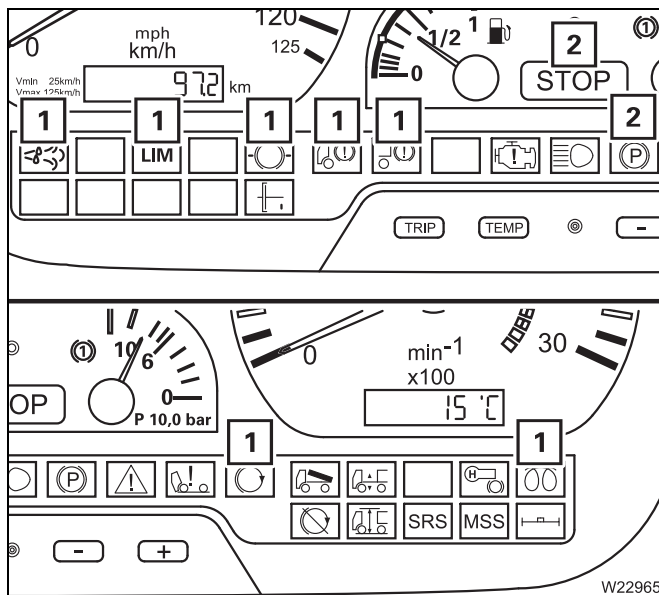

- Check that the lamps (1) light up briefly, if they are present. If the specified time is insufficient, switch on the ignition again.
- If necessary, engage the parking brake and check that the lamps (2) light up continuously.

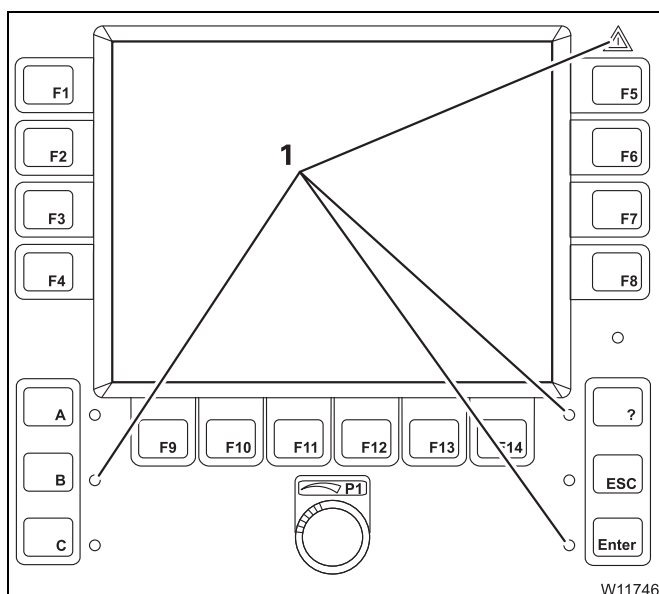

- Check that the lamps (1) go on for approx. 2 seconds after switching on the ignition:

If one or more lamps do not light up, refer to **Manitowoc Crane Care**.

If you could not check all the lamps in the specified time, you can conduct the lamp test again as follows.



4.2

Turning off the engine

4.2.1

On the ignition lock/with hand-held control



Risk of accident from unsteerable truck crane!

Only turn off the engine once the truck crane is at a standstill. If you remove the ignition key, the steering will lock and you will lose control of the moving truck crane.

If the temperature of the coolant is very high, let the engine run for another one or two minutes at increased idling speed.

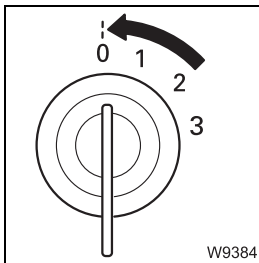

If the hand-held control is not connected:

- Turn the ignition key to position **0** – the engine will stop.

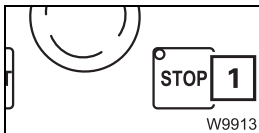

If the hand-held control is connected:

- Press the button **(1)** once – the engine turns off.

It is not possible to switch off the engine with the ignition lock

After turning off

If you want to park the truck crane; ►► p. 5 - 63.

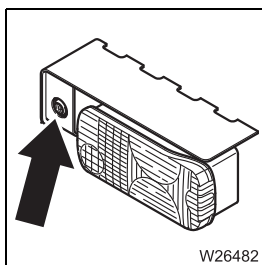

19. Adjust the reverse camera if necessary; p. 5 - 8

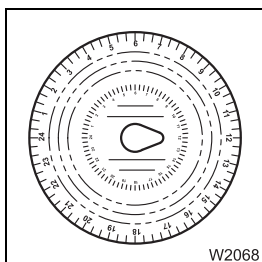

20. Set the tachograph, insert the diagram sheet; p. 5 - 16.

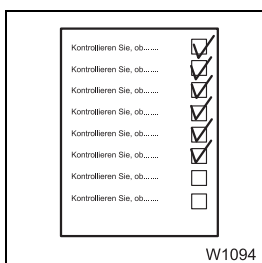

21. Start the engine and carry out all inspections; *Checks after starting the engine*, p. 4 - 17.



22. Check the electrical system; p. 5 - 7.

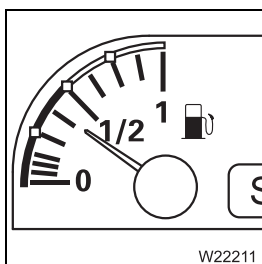

23. Check the consumable reserve; *Monitoring elements*, p. 4 - 18.

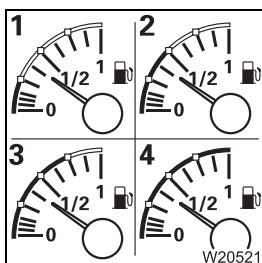

24. Check the DEF filling level if necessary; *Monitoring elements*, p. 4 - 18.



Switching on the suspension

The suspension cylinders are enabled when the suspension is switched on. This state must be established for on-road driving.



Danger of overturning when switching on the suspension

Only switch on the suspension when the truck crane has been rigged for on-road driving and the main boom has been set down. Were the rigged truck crane on wheels, the suspension struts would be suddenly pushed together when the crane was switched on, causing them to be damaged and possibly causing the truck crane to overturn.

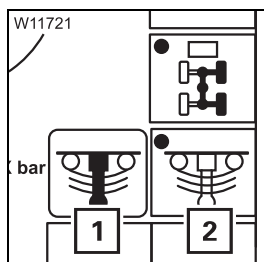

- Press the button (2) once – dot is **green**.

When the suspension is switched on, the symbol (1) is **green**.

When the symbol (1) stays **red**, the supply pressure may be too low. In this case the suspension would only be switched on if sufficient supply pressure is built up; *Building up supply pressure*, p. 5 - 10.

Switching off the suspension

The suspension cylinders are locked when the suspension is switched off. This state is only intended for crane operation.



Risk of damage to the axle lines

Always switch on the suspension for on-road driving. The axle lines may become damaged and the steering behaviour may change if the suspension is switched off.

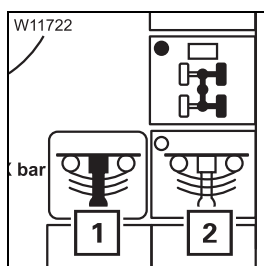

- Press the button (2) once – dot **black**.

When the suspension is switched off, the symbol (1) is **red**.

Alarm clock

- Open the required submenu;  p. 5 - 23.

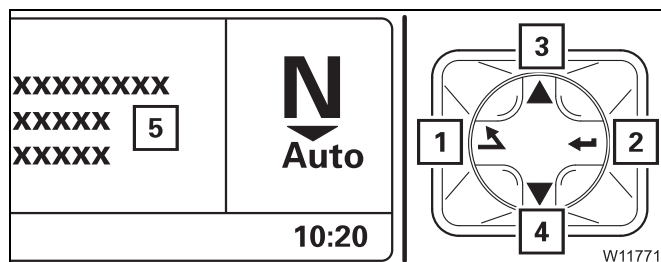

Setting the alarm time

Text (5): Setting the hours

- Use (3), (4) to set, and (2) to store.

Text (5): Setting the minutes

- Use (3), (4) to set, and (2) to store.

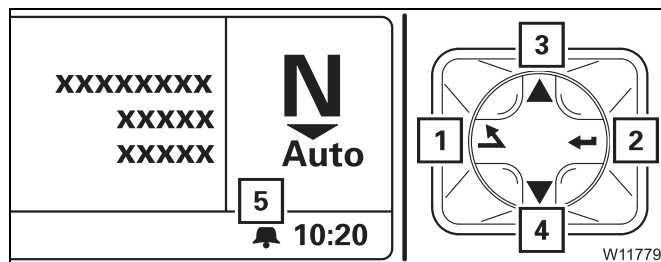

Setting the alarm mode

- Select with (3), (4):
 - Radio/buzzer/off.
- Store with (2), symbol (5) = alarm clock on.

Switch off the alarm signal with (1), (2), (3) or (4)

For a radio alarm, a suitable radio is required.

Language

- Open the required submenu;  p. 5 - 23.

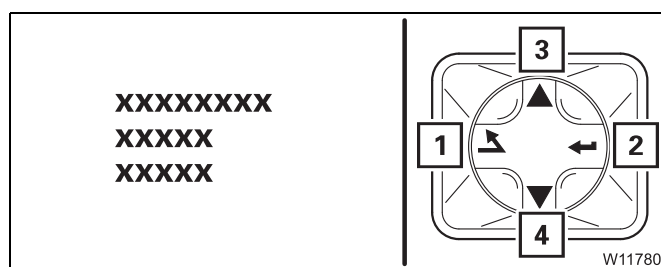

- Select the language with (3), (4).
- Store with (2) – all texts on the *Driving* display are shown in the selected language.



5.2.6

Starting



Risk posed by unexpected rolling!

Also apply the parking brake before starting on sloping ground. The gear will only be engaged after you step on the accelerator. This can lead to the truck crane starting to move (also backwards) while you are moving your foot from the brake pedal to the accelerator.

To start moving, you have to:

- Apply the parking brake,
- step on the accelerator (starts clutching),
- release the parking brake after the gear has engaged (motor sound changes).

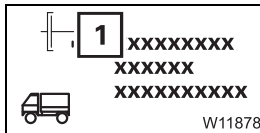

Warning when starting

When the load during starting is so large that it would cause the clutch to overheat, a warning buzzer sounds. The message (1) also appears; p. 5 - 60.

- In this case, remove your foot from the accelerator immediately and apply the service brake.



Risk of clutch damage

Always release the accelerator when the lamp (1) lights up. The clutch will become overheated and damaged if you do not stop the starting procedure.

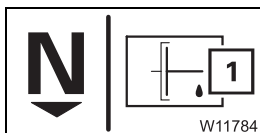

- Switch to neutral position and leave the vehicle engine running until the coupling has cooled down and the message (1) is no longer shown on the display.
- Select a lower starting gear.
- Start to move again.



When driving extremely slowly, the transmission switches automatically to manoeuvring mode and the truck crane responds more sensitively to the accelerator.

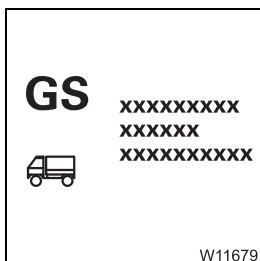

When a transmission malfunction is detected, the *On-board computer display* shows corresponding entries; *Messages on the on-board computer display*, p. 5 - 54.

Switching off

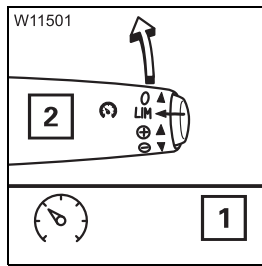

- Push the switch (2) forwards once. The Tempomat is switched off, and the display (1) disappears.

Cruise control is also switched off,

- when the service brake or additional brake is applied,
- when 10 km/h is exceeded,
- when the Temposet function is switched on,
- when the ignition is switched off,
- and when you push the switch forwards once.

5.3.3

Temposet

You can use Temposet to limit the maximum speed.

Switching on

You can only switch on Temposet at speeds of over 15 km/h.

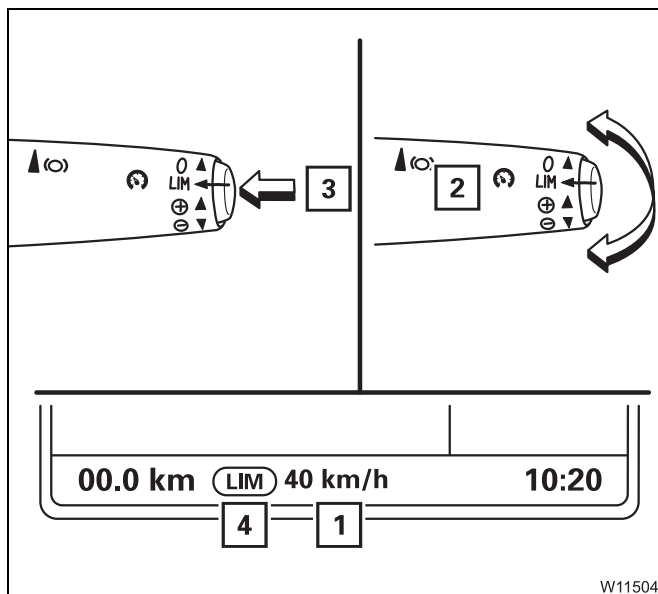

- With the button (3), switch the Temposet on – symbol (4) is shown.
- Press the switch (2) upwards/downwards once.

Cruise control is switched on. The current speed (1) is shown and is used as the maximum speed, e.g. 40 km/h.

You can exceed the speed (1) by pressing the accelerator as far down as it will go (kick-down). The Temposet only goes back down to the speed (1) when you release the accelerator and press it again.



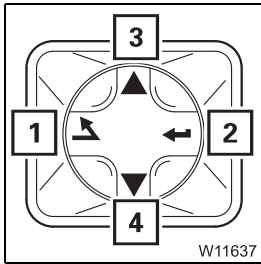

Acknowledging a message

- Press (1) once – the message disappears.

You can retrieve all existing messages in the *Error info* submenu;
▮▮▮▮ p. 5 - 22.

Information

This section does not include all messages. The messages shown here can also appear with additional or different texts.

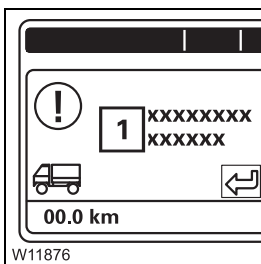

If in doubt, the current text (1) shown in your truck crane always applies.

Follow the requests to stop immediately and conduct the measures given in good time.

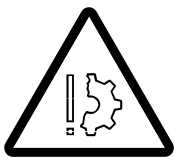

Risk of damage if messages are not observed

For all messages, always take note of the text shown.

Follow the requests to stop immediately, taking the traffic situation into account. Complete the remedial measures shown, and described here, in good time.

This avoids errors, and slight damage leading to more serious problems.

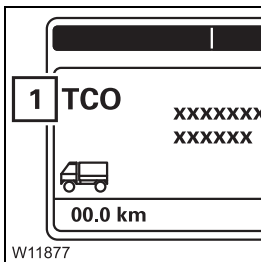

If an abbreviation (1) is shown, you can read off the error codes for the corresponding control device.

Always read off the error codes before contacting **Manitowoc Crane Care**.

For an overview of the control devices and reading off the error codes;

▮▮▮▮ p. 5 - 26.



5.4

Off-road driving

This section describes adjustments, connections and procedures for adapting the vehicle handling to off-road conditions.

Adjustments to the transmission

If you drive continuously, for short periods of time with different loads or on a slippery surface, the transmission may switch gears too late or too early. In this case you can make the following adjustments:

- Shift to a lower starting gear; ■■■▶ p. 5 - 34.
- Step on the accelerator as far as it will go when starting – starting mode for load on.
- Select the *Manual* operating mode. This way you will be able to drive carefully and promptly shift gears; ■■■▶ *Changing the operating mode*, p. 5 - 30.

Connections

If the adjustments to the transmission are insufficient on their own, you can additionally connect the following one after the other:

- First, you can switch on the **off-road gear** in the transfer case; ■■■▶ p. 5 - 66.
- Then switch on the **longitudinal differential locks**; ■■■▶ p. 5 - 67.
- then switch on the **transverse differential locks**; ■■■▶ p. 5 - 67.

Changing the vehicle level

You can also adapt the truck crane to the off-road inclination using the level adjustment system, or lift and lower the truck crane; ■■■▶ p. 5 - 69.

Rocking the vehicle free and towing

If the truck crane is stuck in terrain; ■■■▶ *Freeing truck crane stuck in terrain*, p. 5 - 73.

5.4.5

Separate steering

There are two types of steering with separate steering.

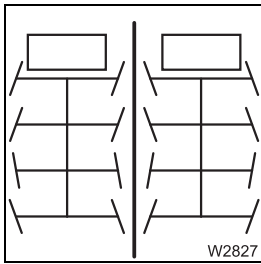

– Driving around corners:

When the separate steering is switched on, the steering angle is larger than for normal steering mode – the turning circle is smaller.

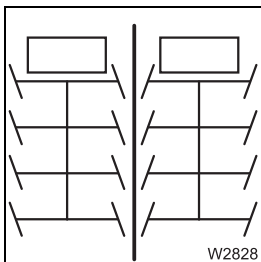

– Crab travel mode:

When the separate steering is switched on, the truck crane drives sideways if you turn the wheels of the front and rear axle lines in the same direction.

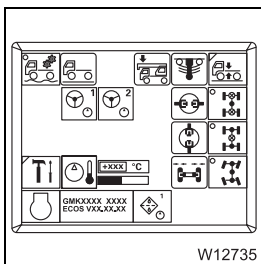

- Open the main menu, if necessary.

Switching to separate steering

Always switch to separate steering when:

- driving with the rigged truck crane or
- steering at low speed.



Risk of accident when driving on-road with unlocked steering

After driving with separate steering, change over immediately to normal steering. The locking status for normal steering mode is only restored once the green *Locked* symbol  is displayed.

You can only change over to separate steering when the current speed is below approx. 5 km/h.





This section describes how to switch on the heater manually. The auxiliary heater can also be switched on automatically; *Storing the heating start*, p. 5 - 86.

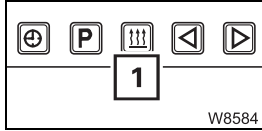

- Turn on the ignition; *Switching on the ignition*, p. 4 - 10.
- Press the button (1) once.
The auxiliary heater switches on automatically – the control field lights up.



Always switch off the auxiliary heater when you turn off the truck crane when the battery master switch is switched on. In this way, you prevent the auxiliary heater from restarting and the batteries from running down after the engine has cooled down.

Temperature

You can preselect a temperature. The preselected temperature is automatically set and maintained.

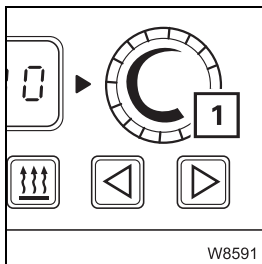

Increasing the temperature:

- Turn the switch (1) clockwise.

Reducing the temperature:

- Turn the switch (1) anti-clockwise.

The higher the selected temperature is, the faster the fan of the auxiliary heater runs.

Setting the day and time

Always set the current time and current day of the week. These settings are required for the correct activation point of the automatic heating start.



If the power supply is interrupted, all symbols in the display will flash and you must set the time and day again.

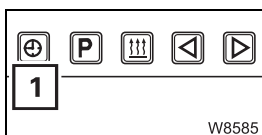

- Press the button (1) for longer than 2 seconds.
The displayed time flashes, e.g. 10.00.

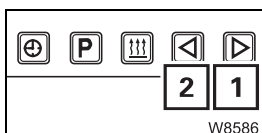

- Set the current time on the flashing display – button (1) or (2), e.g. 14.00.



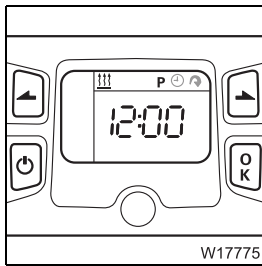

If you have set a preselection time (departure time) of e.g. 12.00 and a heating period of 30 minutes, the auxiliary heater starts at 11.30, for example.

Deleting preselection times

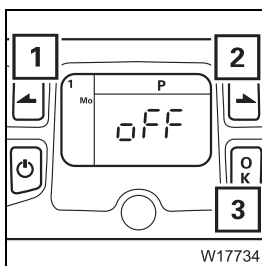

- To delete the preselection times, repeat the steps for setting preselection times;  *Setting the preselection time*, p. 5 - 93.
- Press button (1) or (2) until the *Off* display appears and confirm with button (3).

The preselection time is deleted.

Switching off

This section only describes how to switch off the heater manually. If the auxiliary heater is switched on automatically, it switches off after the set heating period has elapsed;  *Setting the heating period*, p. 5 - 94.

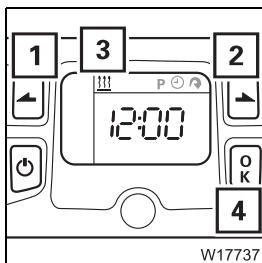

- Use button (1) or (2) to select the symbol (3) and confirm with button (4).
- The auxiliary heater switches off.



If you turn off the auxiliary heater before the set heating period has elapsed, the auxiliary heater continues to run for a certain period of time.



Risk of accident if the trailer is coupled improperly

If the pin is protruding from the guide bushing, the trailer is not coupled properly and could become disengaged from the towbar coupling while driving.

Connecting the supply lines

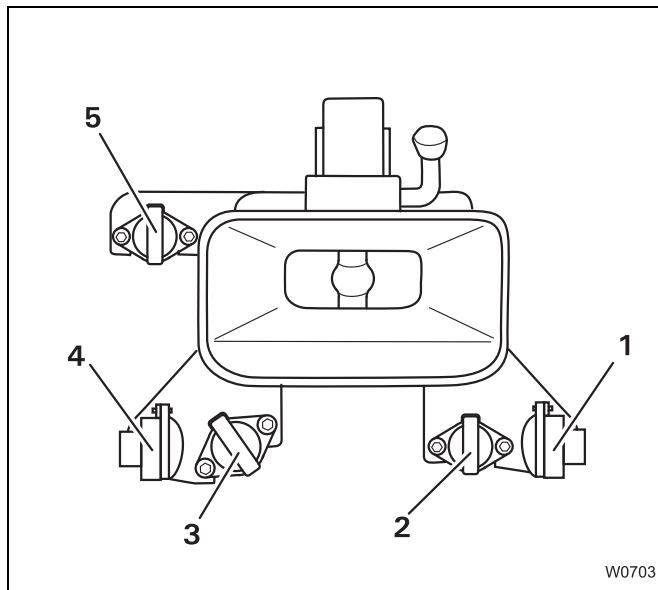

- Insert the plug of the trailer's electrical system into the socket (5).
- If necessary, insert the ABS connection cable into the socket (3).
- First connect the hose of the brake cable to the yellow coupling head (4).
- Then connect the hose of the supply line to the red coupling head (1).

This socket (2) is designed for special equipment.



Risk of accident if the hoses are too short or installed improperly

The hose lines may not come off even when driving around corners. When connecting the hoses, make sure they are long enough and have enough clearance.

- Check the function of the trailer lighting.
- Test the service brake and parking brake immediately after setting off.



For 20.5 R25 tyres Also observe the effects on the axle loads when towing a trailer;
 p. 5 - 103.

		Driving mode				
		1	2	3	4	5
Equipment	20.5 R25 tyres	✓	✓	✓	✓	✓
	Drive 8 x 6 x 8	✓	✓			
	Drive 8 x 8 x 8			✓	✓	✓
	Eddy current retarder		✓		✓	✓
	Auxiliary hoist or 0.6 t weight installed	✓	✓	✓	✓	✓
	Fuel tank on the superstructure	✓			✓	✓
Rigging mode	20.5 R25 spare wheel on rear				●	●
	Single-sheave hook block attached to the bumper ¹⁾				●	
	3-sheave hook block attached to the bumper ¹⁾	●	●	●		●
	10 m lattice extension folded to the side				●	
	17 m lattice extension folded to the side	●	●	●		
	6.3 t counterweight attached to the turntable	●	●	●		
	4.1 t counterweight attached to the turntable				●	●

¹⁾ The weight of the hook blocks is based on the information in this operating manual;  p. 1 - 11.

7

Malfunctions in driving mode

7.1

Emergency stop switch

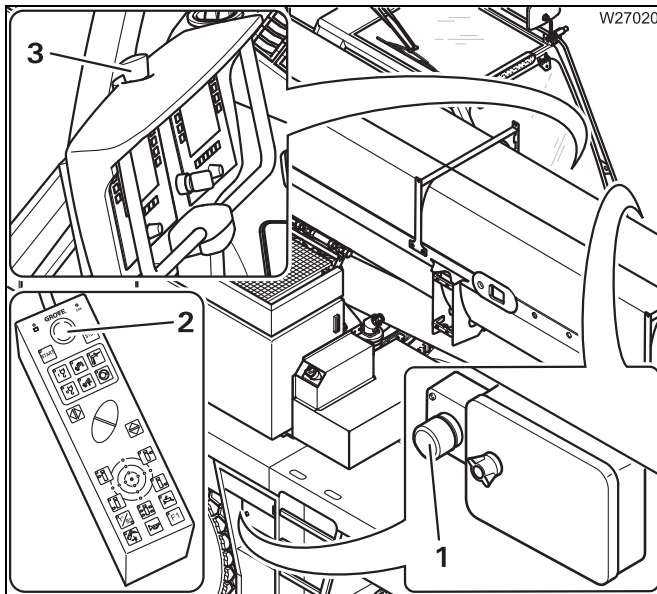

Four emergency stop switches are provided for an emergency:

- 1 On the carrier
- 2 On the hand-held control
- 3 In the crane cab

- Press an emergency stop switch (1), (2) or (3). The switch engages.

The engine shuts down. If the engine for crane operation has previously been started, it is also shut down.

After activating an emergency stop switch;
▣► *Resetting the emergency stop switch*, p. 4 - 22.



The battery master switch cannot be used as an emergency stop switch for the engine. The engine continues to run after the battery master switch has been switched off.

7.4

Wheels and tyres

This section contains all the information about changing a wheel and about using the tyre inflator connection.

7.4.1

Wheel change

- If a puncture occurs while driving, stop the truck crane, taking the following traffic into account, and secure the truck crane as outlined in the applicable legal stipulations of the country in which you are working.
- Select an even place, if possible, to change the wheels.



Risk of accident by falling wheel

If you briefly lean a wheel against the truck crane while changing it, secure it with a rope to prevent it from falling over. Only move the outriggers when no wheel is leaning against the truck crane.

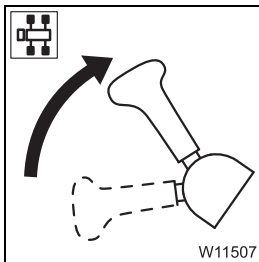

- Engage the parking brake.

Removing a damaged wheel

- Switch off the suspension;  p. 5 - 15.
- Raise the truck crane with the outriggers until the wheel to be changed just barely leaves the ground.



Risk of accident by falling wheel

When unscrewing the final lug nuts, the wheel can slip off the hub and fall toward you. Secure the wheel and step back quickly if the wheel begins to tip.

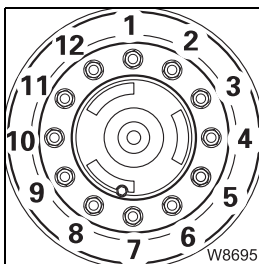

- Remove the wheel nuts (1) to (12) and remove the damaged wheel.
- Secure the wheel against falling over if you set it down temporarily.



A2 Designation	Amper- age (A)	Function
F1	–	Unassigned
F2	–	Unassigned
F3	10	Hand-held control
F4	10	Transmission retarder
F5	10	Heating system
F6	10	DEF system
F7	10	Steering
F8	2	Daytime driving light, left
F9	2	Daytime driving light, right
F10	–	Unassigned
F11	–	Unassigned
F12	–	Unassigned
F13	–	Unassigned
F14	–	Unassigned

A3 Designation	Amper- age (A)	Function
F1	20	Oil cooler
F2	5	ECOS control unit
F3	10	ESX3 control unit
F4	10	Steering lock query (for driving from the superstructure)
F5	10	Vehicle height monitor 
F6	10	DEF system heater
F7	15	Outrigger lighting
F8	10	Central lubrication
F9	10	Generator, tachograph, engine control



7.6.12 Malfunctions on the ECOS carrier

This section contains general malfunctions and malfunctions that generate an “error” display. It also contains information on reading error messages on the *Outrigger* control units.

ECOS programme version

Always note down the number of the program version after a malfunction occurs before notifying **Manitowoc Crane Care**.

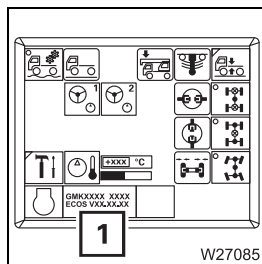

- Open the main menu, if necessary.

The display (1) shows the number of the current programme version.

General malfunctions

The following table contains information on troubleshooting and possible solutions.

Malfunction	Cause	Solution
Ignition on – ECOS display does activate	Fuse A3F2, A3F10 blown.	Replace the blown fuse; ➡ p. 7 - 20.



If further malfunctions occur, the appropriate error messages are shown in the *ECOS* display.



Stopping

The clutch is disengaged automatically when the accelerator is released, if this is still possible.

If automatic disengaging is no longer possible, the vehicle engine will be throttled as soon as you stop the truck crane using the service brake.

Emergency gear shift

If you park the truck crane in gear and the pressure in the reservoirs falls below 5.5 bar. You can

- not start the engine since the transmission is not in neutral position,
- not shift the transmission into neutral position because the pressure is below 5.5 bar and
- not fill the reservoir because the engine is not running.

In this situation, you can shift into neutral position using an emergency gear shift in order to start the engine.

In addition you can also shift the transmission mechanically to neutral position or select a gear if it is no longer possible to select gears with the operating elements in the driver's cab.

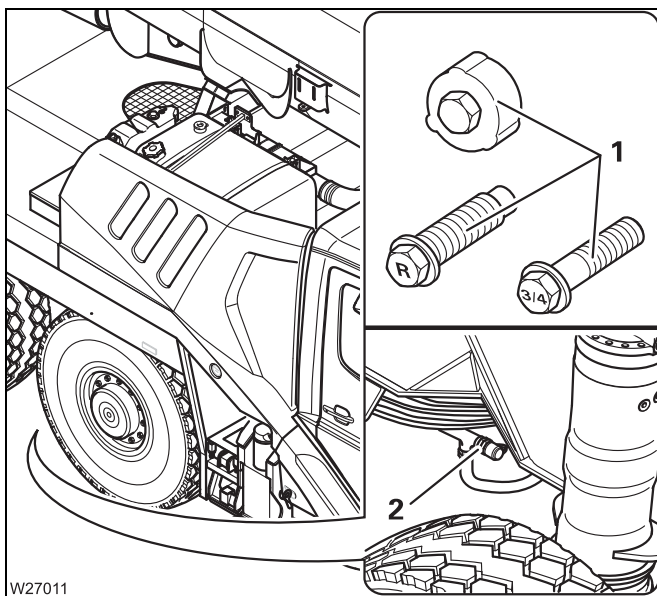

The type of emergency gear shift depends on the equipment of the truck crane.

Mechanical emergency gear shift

The truck crane has the accessories (1);

➡ p. 7 - 44.

Compressed air emergency switching

The truck crane has the filler connection (2);

➡ p. 7 - 42.



8 Index

Checks before starting the engine	10 - 9
Malfunctions	14 - 13, 14 - 24
Preheating	5 - 96, 11 - 140
Setting idling speed	10 - 18
Short description of the operating elements	9 - 61
Starting	10 - 14
Starting – checklist	10 - 1
Switching on the ignition	10 - 10
Turning off	
During normal operation	10 - 21
In emergencies	10 - 22
Engine for driving	
Air intake inhibitor	4 - 23
Diagnostics	3 - 61
Malfunctions	7 - 23
Operation in the driver's cab	
Checking after starting	4 - 17
Checking the fuel level	4 - 7, 10 - 5
Checks before starting	4 - 9
Lamp test/switching state equalisation	4 - 11
Monitoring elements	4 - 18
Resetting the emergency stop switch	4 - 22
Setting idling speed	4 - 20
Starting	4 - 14
Starting – CHECKLIST	4 - 1
Switching on the ignition	4 - 10
Turning off	4 - 21
Procedure during malfunctions	7 - 36
Refuel	4 - 7, 10 - 5
Starting from the crane cab – for rigging work	12 - 25
F Final drive	
Operating elements in the driver's cab	3 - 49
Front flap	
Opening and closing	3 - 66
Fuel tank	
Dual tank system	4 - 8
Standard tank	4 - 7, 10 - 5
Fuses	
On the carrier	7 - 17
In the battery box	7 - 22
In the driver's cab	7 - 18
On the superstructure	14 - 5
For the RCL	14 - 11
In the crane cab	14 - 8
On the turntable	14 - 6

Opening the working range limiter submenu	11 - 118
Shutdown	11 - 130
Switching monitoring function on/off	11 - 129
View current settings	11 - 119

9 Operating elements for crane operation

9.1	Overview of the operating elements	9 - 3
9.1.1	Exterior of the truck crane	9 - 4
9.1.2	Crane cab	9 - 8
9.1.3	Front panel	9 - 10
9.1.4	Side panel	9 - 11
9.1.5	Control panels	9 - 18
9.1.6	Control lever configuration	9 - 20
9.1.7	ECOS control unit	9 - 22
9.1.8	ECOS display – main menu	9 - 24
9.1.9	ECOS display – submenus	9 - 26
9.1.10	RCL control unit	9 - 42
9.1.11	RCL display – main menu	9 - 44
9.1.12	RCL display – submenus	9 - 45
9.1.13	Hand-held control	9 - 53
9.1.14	Outrigger control units	9 - 56
9.2	Short description of the operating elements	9 - 59
9.2.1	Definition of direction information	9 - 59
9.2.2	General rules for buttons and symbols on the display	9 - 60
9.2.3	Engine for crane operation	9 - 61
9.2.4	DEF system	9 - 63
9.2.5	Engine for driving	9 - 65
9.2.6	Seat contact switch and dead man's switch	9 - 67
9.2.7	ECOS crane control	9 - 69
9.2.8	Outrigger	9 - 72
9.2.9	Inclination indicators	9 - 77
9.2.10	Outrigger pressure displays	9 - 78
9.2.11	Anemometer display	9 - 78
9.2.12	Counterweight submenu	9 - 79
9.2.13	Main hoist	9 - 82
9.2.14	Auxiliary hoist	9 - 84
9.2.15	Slewing gear	9 - 85
9.2.16	Derricking gear	9 - 89
9.2.17	Telescoping mechanism	9 - 90
9.2.18	Hydraulic system	9 - 97
9.2.19	Houselock	9 - 98
9.2.20	Rated capacity limiter (RCL)	9 - 99
9.2.21	Electrical system	9 - 113
9.2.22	Lighting, windscreen wiper/washing system	9 - 113
9.2.23	Hand-held control	9 - 116
9.2.24	Diagnostics	9 - 120
9.2.25	Windows, doors, keys	9 - 120

1	Side panel	▣▣▣▣▶ p. 9 - 11
2	Front panel	▣▣▣▣▶ p. 9 - 10
3	Windscreen	▣▣▣▣▶ p. 9 - 120
4	Standard heating system	▣▣▣▣▶ p. 9 - 15
5	Control panels	▣▣▣▣▶ p. 9 - 18
6	Air vent	▣▣▣▣▶ p. 11 - 134
7	Accelerator	
8	Storage compartment	
9	Service brake pedal	▣▣▣▣▶ p. 9 - 127
10	Windscreen washing system ³⁾	
11	Slewing gear brake – switchable on/off	▣▣▣▣▶ p. 11 - 96
12	Cab lighting	▣▣▣▣▶ p. 9 - 114
13	Auxiliary water heater	▣▣▣▣▶ p. 9 - 16
	Auxiliary air heater	▣▣▣▣▶ p. 9 - 17
14	Loudspeakers	
15	Radio/CD/USB ^{1), 2)}	
16	Console, rear	▣▣▣▣▶ p. 9 - 14
17	Fan with switch ¹⁾	
18	Rear window	▣▣▣▣▶ p. 9 - 121
19	Crane cab seat – Version 1	▣▣▣▣▶ p. 11 - 7
	Crane cab seat – Version 2 ¹⁾	▣▣▣▣▶ p. 11 - 7
	Seat contact switch	▣▣▣▣▶ p. 9 - 67
20	Cover for	
	– Fuses	▣▣▣▣▶ p. 14 - 8
	– CraneSTAR system ¹⁾	▣▣▣▣▶ p. 11 - 149
21	Intake/air vents	▣▣▣▣▶ p. 11 - 133
22	Door unlocking mechanism	▣▣▣▣▶ p. 9 - 122

¹⁾ Additional equipment

²⁾ ▣▣▣▣▶ *Separate engine operating instructions*

³⁾ ▣▣▣▣▶ *Maintenance manual*

Right

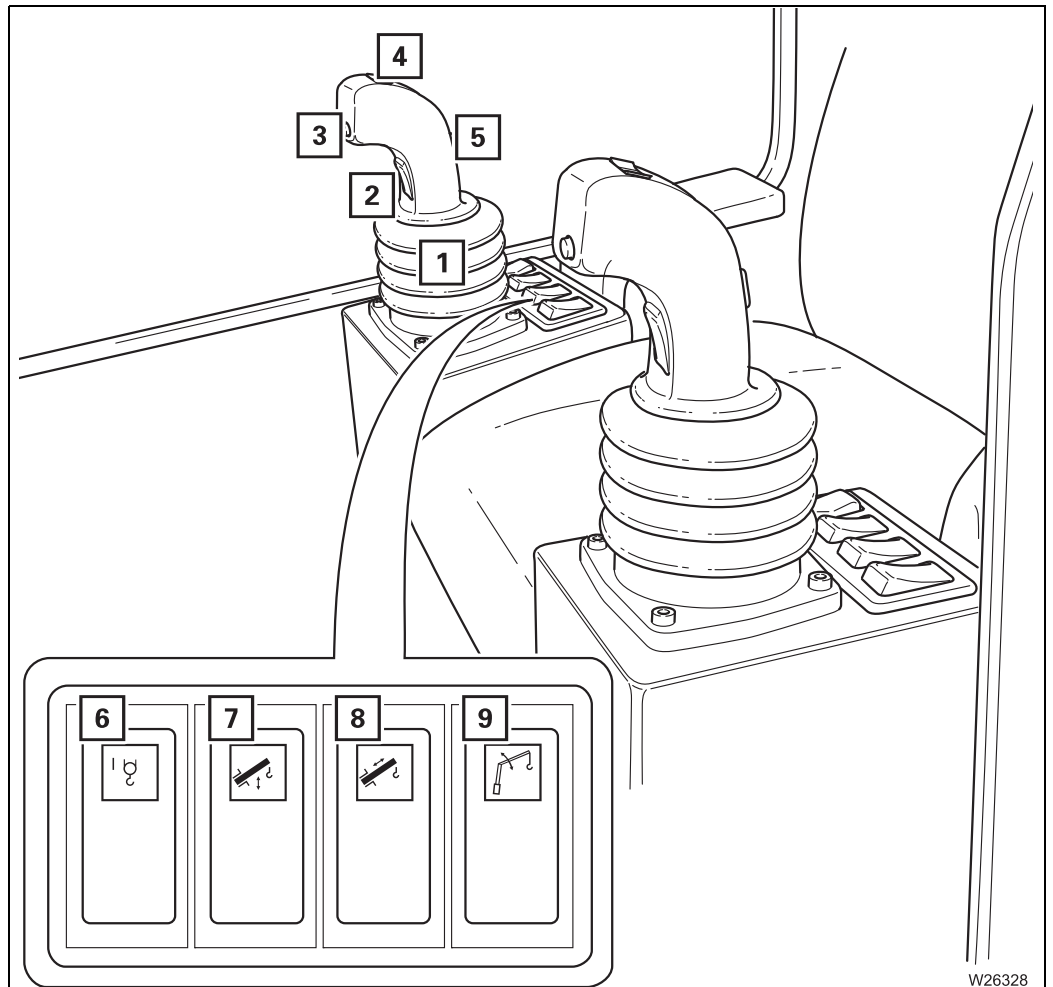

W26328

- 1 Right-hand control lever (configuration depends on version) ▣ p. 9 - 20
- 2 Dead man's switch ▣ p. 9 - 67
- 3 Horn button
- 4 Depending on which function is activated, button for:
 - Hoist high-speed mode on/off ▣ p. 9 - 83
 - Steering in normal steering mode ▣ p. 9 - 129
- 5 Main hoist slewing indicator ▣ p. 11 - 54
- 6 Main hoist on/off ▣ p. 9 - 82
- 7 Derricking gear on/off ▣ p. 9 - 89
- 8 Telescoping mechanism on/off ▣ p. 9 - 90
- 9 Derrick lattice extension on/off^{1), 2)}

1) Additional equipment

2) ▣ *Lattice extension operating manual*

1	All supporting cylinders	▶▶▶▶▶ p. 9 - 74
2	Front right outriggers	▶▶▶▶▶ p. 9 - 74
2.1	Front right-hand outrigger pressure display ¹⁾	▶▶▶▶▶ p. 9 - 78
3	Right supporting cylinder	▶▶▶▶▶ p. 9 - 74
4	Rear right outriggers	▶▶▶▶▶ p. 9 - 74
4.1	Rear right-hand outrigger pressure display ¹⁾	▶▶▶▶▶ p. 9 - 74
5	Extending the outrigger beam	▶▶▶▶▶ p. 9 - 74
6	Retracting the outrigger beam	▶▶▶▶▶ p. 9 - 74
7	Rear supporting cylinder	▶▶▶▶▶ p. 9 - 74
8	Front supporting cylinder	▶▶▶▶▶ p. 9 - 74
9	Extend supporting cylinders	▶▶▶▶▶ p. 9 - 74
10	Retract supporting cylinders	▶▶▶▶▶ p. 9 - 74
11	Rear left outriggers	▶▶▶▶▶ p. 9 - 74
11.1	Rear left-hand outrigger pressure display ¹⁾	▶▶▶▶▶ p. 9 - 74
12	Left supporting cylinder	▶▶▶▶▶ p. 9 - 74
13	Front left outriggers	▶▶▶▶▶ p. 9 - 74
13.1	Front left-hand outrigger pressure display ¹⁾	▶▶▶▶▶ p. 9 - 74
14	Switch measuring range	▶▶▶▶▶ p. 9 - 77
15	Current inclination indicator	▶▶▶▶▶ p. 9 - 77
16	Angle direction display	▶▶▶▶▶ p. 9 - 77
17	Slewing gear/movements locked display	▶▶▶▶▶ p. 9 - 73
18	Carrier ignition display	▶▶▶▶▶ p. 9 - 66
19	Display for engine for driving on/off	▶▶▶▶▶ p. 9 - 66
20	Start engine for driving	▶▶▶▶▶ p. 9 - 66

¹⁾ Additional equipment



Enter slewing angle submenu

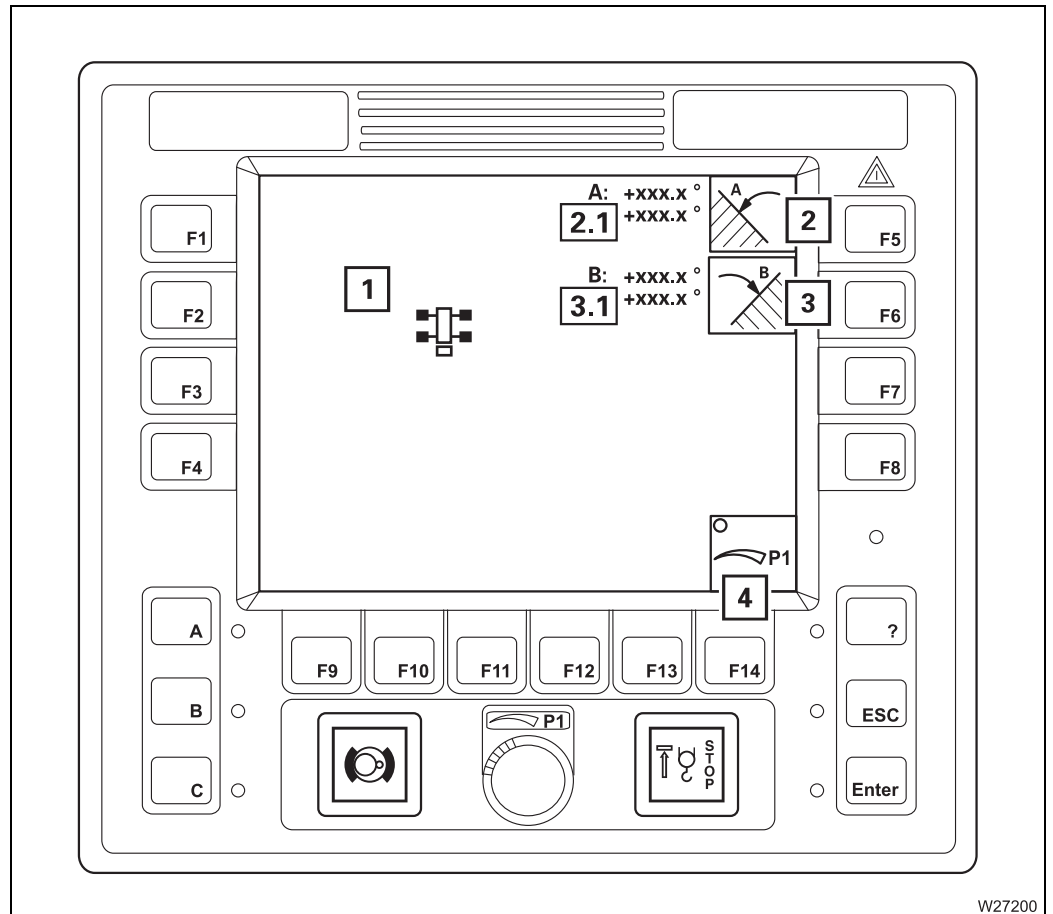

W27200

- | | |
|--|-------------------|
| 1 Limited slewing angle display | ▣▣▣▣▶ p. 11 - 122 |
| 2 Select slewing angle A | ▣▣▣▣▶ p. 11 - 122 |
| 2.1 Maximum/current slewing angle A display | ▣▣▣▣▶ p. 11 - 122 |
| 3 Select slewing angle B | ▣▣▣▣▶ p. 11 - 122 |
| 3.1 Maximum/current slewing angle B display | ▣▣▣▣▶ p. 11 - 122 |
| 4 Manual input on/off | ▣▣▣▣▶ p. 11 - 127 |



Submenu Lifting capacity table

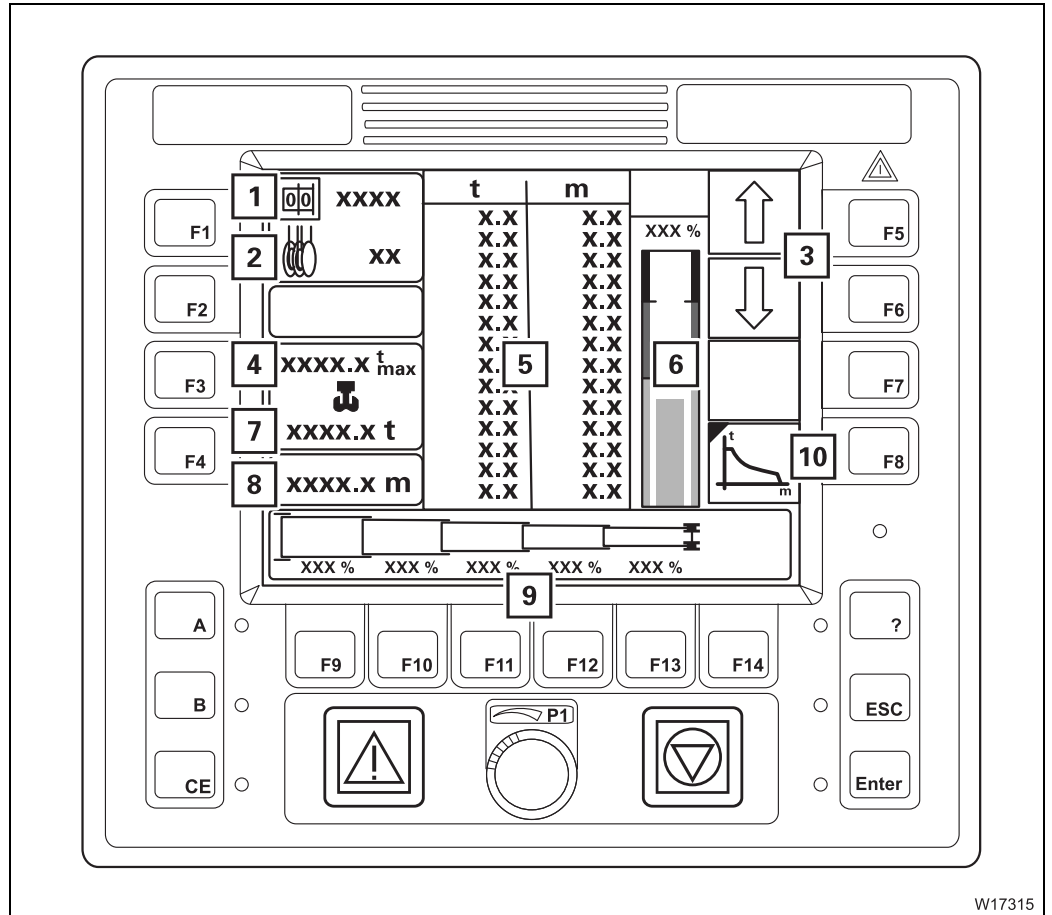

W17315

- | | |
|--|------------------|
| 1 RCL code display | ▣▣▣▣▶ p. 9 - 110 |
| 2 Reeving display | ▣▣▣▣▶ p. 9 - 110 |
| 3 Selection | |
| 4 Maximum load display | ▣▣▣▣▶ p. 9 - 110 |
| 5 Lifting capacity table display | ▣▣▣▣▶ p. 9 - 109 |
| 6 Current degree of utilisation display | ▣▣▣▣▶ p. 9 - 110 |
| 7 Current load display | ▣▣▣▣▶ p. 9 - 110 |
| 8 Current working radius display | ▣▣▣▣▶ p. 9 - 110 |
| 9 Telescope status display/input | ▣▣▣▣▶ p. 9 - 110 |
| 10 Working range submenu Work area ¹⁾ | ▣▣▣▣▶ p. 9 - 50 |

¹⁾ Additional equipment



9.2

Short description of the operating elements



Risk of accident by operator error

This section is not a complete operating manual. It only provides a general overview of the functionality of the operating elements. Before using the operating elements for the first time, read through the following chapters and the safety instructions listed there.

This section does not contain all the requirements that must be fulfilled for several operating elements to be active.

If some operating elements do not work, first read the following chapters which are referred to at the respective places before contacting **Manitowoc Crane Care**.

9.2.1

Definition of direction information

Basic rule

Direction information always depends on whether the carrier or the superstructure is being operated.

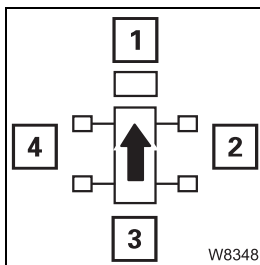

On the carrier

The driver's cab is always at the front, which means that:

- | | |
|----------|----------|
| 1: front | 2: right |
| 3: rear | 4: left |

Reverse always means the rear lights on the carrier are to the front, **Backwards** always means with the rear lights on the carrier are leading.

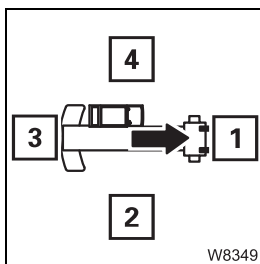

On the superstructure

The main boom head is always at the front, which means that:

- | | |
|----------|----------|
| 1: front | 2: right |
| 3: rear | 4: left |

Switches

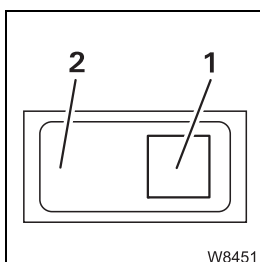

For switches and buttons, the terms **down** and **up** are used.

Regardless of the fitting position (vertical, horizontal, diagonal, perpendicular or turned), the following always applies:

- **Down:** if (1) press – next to the symbol
- **Up:** if (2) press – opposite the symbol

9.2.7

ECOS crane control

The truck crane GMK 4100 is equipped with the **ECOS** electronic crane control (**E**lectronic **C**rane **O**perating **S**ystem). The ECOS includes a control unit in the crane cab, an operating unit in the driver's cab and several control units (ESX0, ESX1, ESX2 etc.) and I/O circuit boards (I/O 0, I/O 1 etc.) distributed on the superstructure and carrier.

Control unit

This section contains the operating elements that are the same for all menus opened.

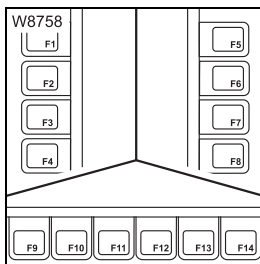

Buttons F1 to F14

The function of buttons F1 to F14 is shown on the symbol next to or above the button. After the button is pressed, the function displayed is executed provided it has been released.

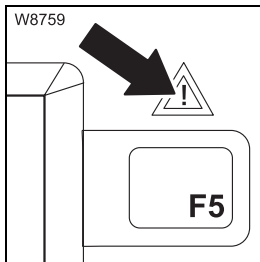

Error/warning message

- **Flashing:** New warning message or error has occurred
- **On:** Error acknowledged – but still present
- **Off:** No warning message or error present

➡ p. 11 - 115

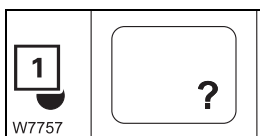

Opening the Error submenu

The lamp (1) lights up or flashes.

- **Press the button once:** This opens the *Errors* submenu

➡ p. 11 - 115

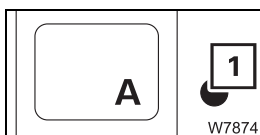

Opening the Warning submenu (superstructure)

The lamp (1) lights up or flashes.

- **Press the button once:** This opens the *Warning* submenu for the superstructure

➡ p. 11 - 110



9.2.12 Counterweight submenu

Counterweight submenu

- ▣▣▣▣ *Rigging/unrigging the counterweight*, p. 12 - 57,
- ▣▣▣▣ *Counterweight hoist unit*, p. 12 - 78.

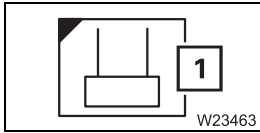

Counterweight submenu

1 – To open: Press button once – submenu opens

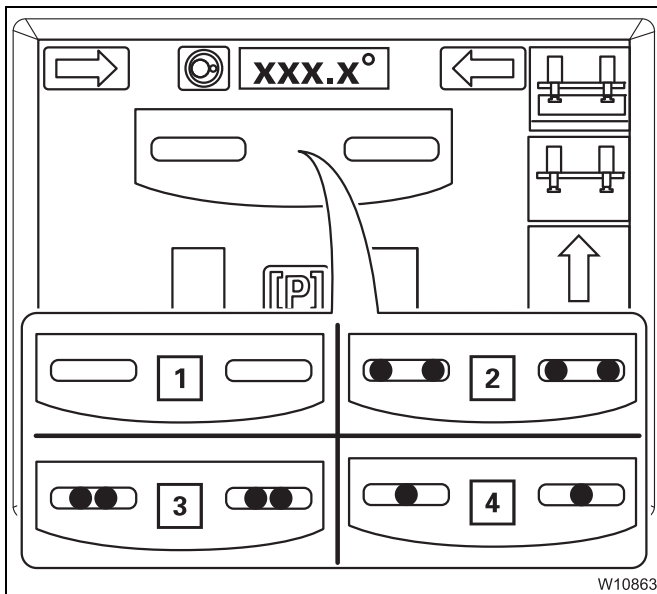

Rigging position display

1 White – not in the rigging range

In the rigging range, the following rigging positions are displayed.

- 2** Green – position for lifting cylinder movements
- 3** Red – intermediate position, lifting cylinder movements blocked
- 4** Green – position for lifting/lowering the counterweight (0° position)

▣▣▣▣ p. 12 - 80

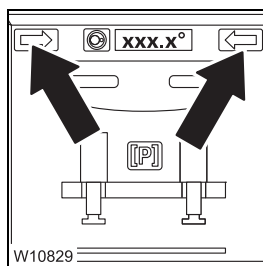

Display of slewing direction for automatic mode

The automatic mode is switched on.

- **Arrow lights up:** Move control lever for slewing gear in direction of arrow – automatic mode is executed



9.2.16

Derricking gear

▣▣▣▣► *Derricking gear*, p. 11 - 63.

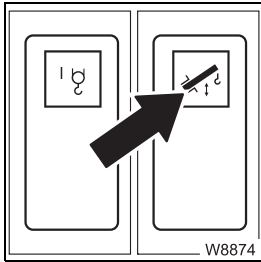

Derricking gear on/off

There is a lamp in the button.

- **Press once** - Lamp bright – derricking gear on,
 Power units with the same control lever configuration
 off
- Lamp dim – derricking gear off

▣▣▣▣► p. 11 - 64

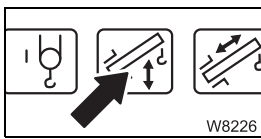

Power units display

- **Green:** Derricking gear on
- **Red:** Derricking gear off

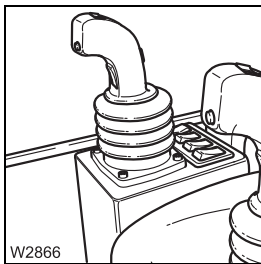

Right control lever

- **To the left:** Raise – lift main boom
- **To the right:** Lower – lower main boom

▣▣▣▣► p. 11 - 64

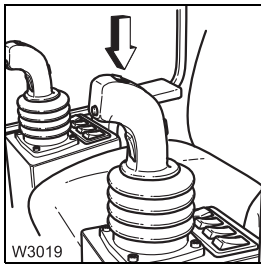

Derricking gear/telescoping mechanism high-speed mode on/off

The parking brake is engaged.

- **Left:** High-speed mode on, off when released
- **Once to the right:** High-speed mode on – continuous operation
- **Once to the right** High-speed mode off
 or
 once to the left:

▣▣▣▣► p. 11 - 94

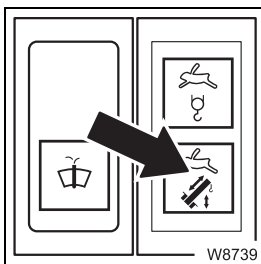

High-speed monitoring for derricking gear/telescoping mechanism

- **On:** High-speed mode on
- **Off:** High-speed mode off

▣▣▣▣► p. 11 - 94

30.06.2014

CLICK HERE TO **DOWNLOAD** THE COMPLETE MANUAL

- Thank you very much for reading the preview of the manual.
- You can download the complete manual from: www.heydownloads.com by clicking the link below



- Please note: If there is no response to CLICKING the link, please download this PDF first and then click on it.

CLICK HERE TO **DOWNLOAD** THE COMPLETE MANUAL

9.2.20

Rated capacity limiter (RCL)

Control unit

This section contains the operating elements that are the same for all menus opened.

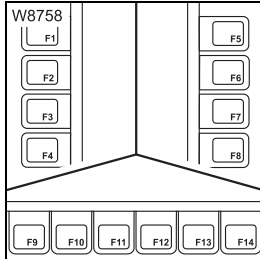

Buttons F1 to F14

The function of buttons F1 to F14 is shown on the symbol next to or above the button. After the button is pressed, the function displayed is executed provided it has been released.

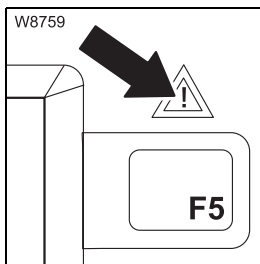

Error

- On: Error has occurred
- Off: No errors

➡ p. 11 - 38

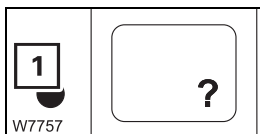

Opening the Error submenu

The lamp (1) lights up or flashes.

- Press the button once: This opens the *Errors* submenu

➡ p. 14 - 30



Exiting the submenu/input mode

The lamp (1) lights up.

- Press the button once:
 - The opened submenu closes – the menu from the next higher level is opened
 - Input mode is deactivated



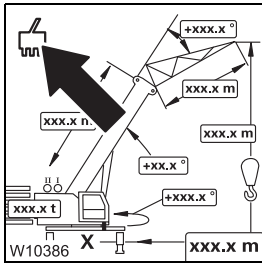

Service symbol display

Symbol displayed – service device connected

Submenu Lifting capacity table

▣▣▣▣▶ *Displaying the lifting capacity tables, p. 11 - 45*

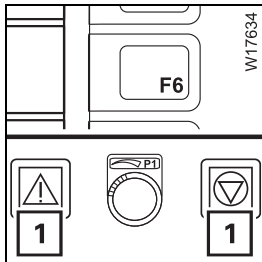

– **To open:** Press the button once – submenu opens, all crane movements are blocked, the lights (1) light up

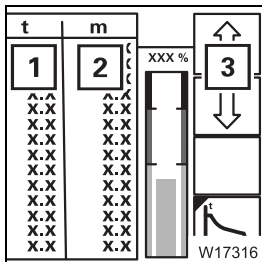

Lifting capacity table display

Values for displayed RCL code and displayed telescope status

- 1 Lifting capacity in tons (t) or in kilopounds (klbs)
- 2 Working radius in metres (m) or feet (ft)
- 3 Show other values given in the table

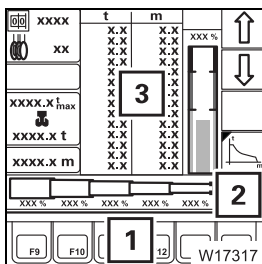

Telescope status display/input

- **Display:** Telescope status (2) in per cent
- **Input:** Press button (1)
 - New telescope status on display (2)
 - Corresponding table on display (3)
 - or all values 0 = no table available

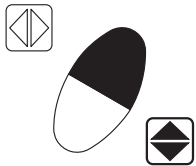
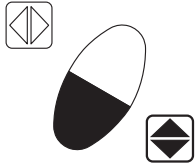
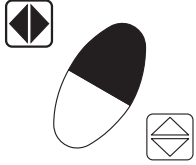
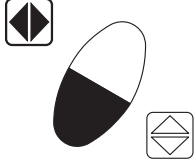

Button combination	Pre-selected power unit				
	Telescoping mechanism	Derricking gear	Slewing gear	Hoists	Lattice extension
 <p>W3851</p>	None	Lower	None	Lower	Lower
 <p>W3850</p>	Retract	Raise	None	Lift	Raise
 <p>W3849</p>	None	None	Slew to right	None	None
 <p>W3848</p>	None	None	Slew to left	None	None

☛ Emergency operation with the hand-held control, p. 14 - 59

Normal steering

Driver's cab: The ignition key is in position **1**.
 Crane cab: The carrier ignition is switched on.

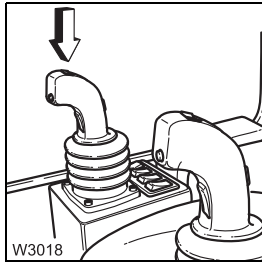

W3018

Steering in normal steering mode

The steering direction for the current superstructure position is switched on.

- Press button on left: Left-hand turn
- Press button on right: Right-hand turn

➡ p. 13 - 15

Separate steering

Driver's cab: The ignition key is in position **1**.
 Crane cab: The carrier ignition is switched on.

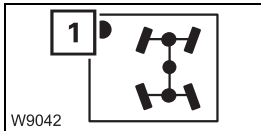

W9042

Separate steering on/off

- Switching on: Press button once – dot (1) green
- Switching off: Press button once – dot (1) black

➡ p. 13 - 16

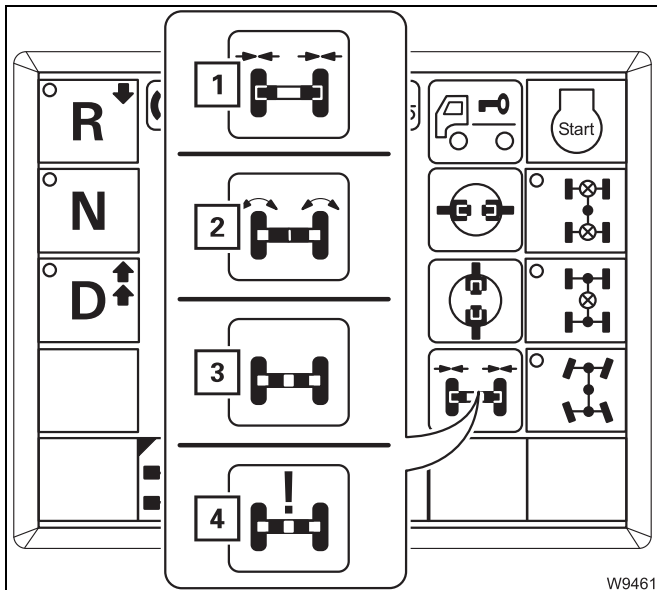

W9461

Steering locking status display

The current status is shown using different symbols:

- 1 Green – locked
- 2 Red – unlocked
- 3 Yellow – intermediate position
- 4 Violet – error

➡ p. 13 - 16

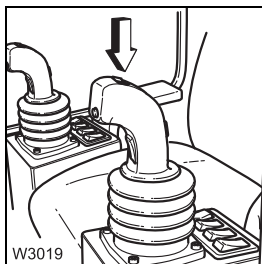

W3019

Steering with separate steering

The steering direction for the current superstructure position is switched on.

- Press button on left: Left-hand turn
- Press button on right: Right-hand turn

➡ p. 13 - 16

DEF tank

Only use permissible consumables;  *Separate engine operating instructions, provided by the manufacturer.*



Risk of accidents if the tank is not closed!

Close the tank each time you have refilled it.

In this way you can prevent other vehicles from being endangered by the cap falling off or consumables escaping.



Risk of damage to the engine and catalytic converter!

Unauthorised consumables can damage the engine and catalytic converter and void the warranty. Only use consumables approved by the engine manufacturer.



Risk of injury from ammonia vapours!

Ammonia vapours can escape if the DEF tank is opened at high outside temperatures. Ammonia vapours can irritate mucous membranes, skin and eyes.

Ensure that there is adequate fresh air supply and do not breathe in the escaping ammonia vapours.

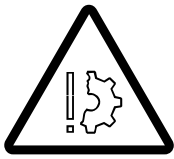

Risk of damage to painted or aluminium surfaces!

DEF can corrode these surfaces. Clean up spilled DEF with water immediately.

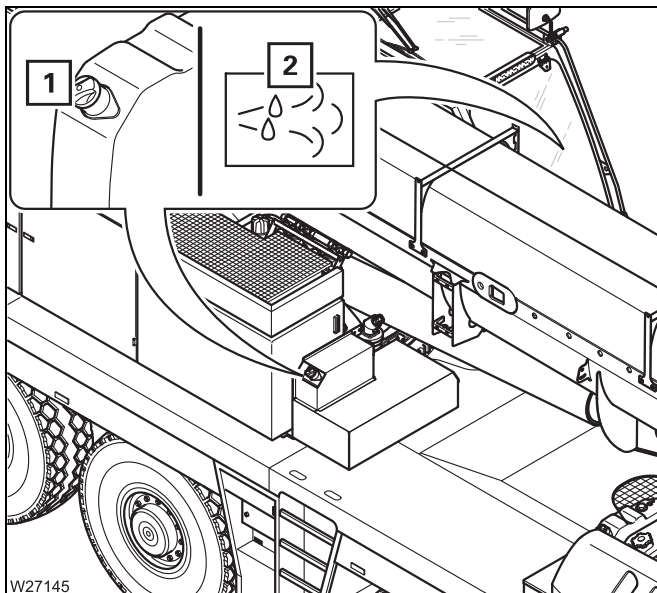

When the DEF tank is almost empty the lamp (2) lights up.

- Refill the DEF tank (1) in good time and seal it using the cap.

If the DEF tank is empty, the lamp (2) will flash a warning and the engine torque will be reduced the next time the engine is started;

 *Notes on torque reduction, p. 11 - 114.*



10.1.10 Monitoring submenu

The *Monitoring* submenu shows the most important measured values.

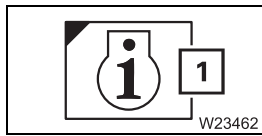

- In the main menu press button (1) once.
This opens the *Monitoring* submenu.

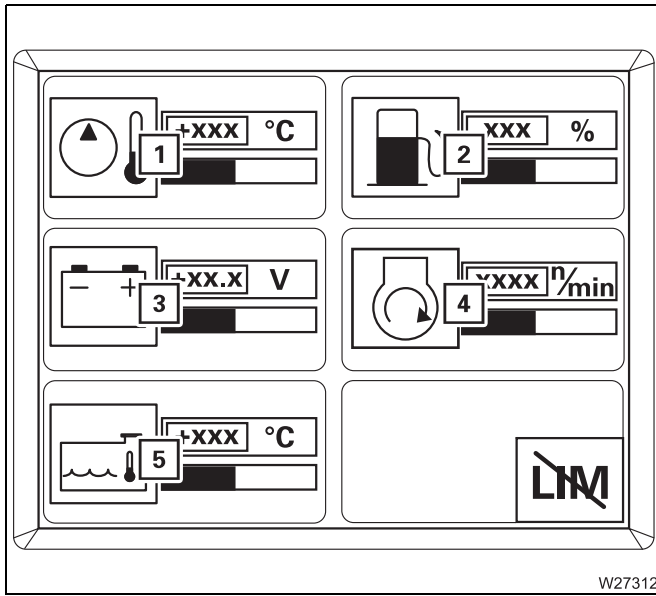

The following values are displayed:

- 1 The hydraulic oil temperature in °C
- 2 The fuel supply as a percentage,
– in the carrier tank or
– in the superstructure tank¹⁾
- 3 Voltage in volts
- 4 Engine speed in rpm
- 5 The coolant temperature in °C

¹⁾ Additional equipment

The colour of the bar below the values indicates in which area the value can be found.

Green: Value OK

Yellow: Limit value almost reached

Red: Limit value exceeded (or not reached) – warning message;
☐➡ p. 11 - 110.

11 Crane operation

11.1 Before operating the crane

11.1.1 CHECKLIST: Checks before operating the crane



This checklist is not a complete operating manual. There are accompanying operating instructions which are indicated by cross-references. **Observe the warnings and safety instructions specified here.**



This checklist only applies to working with a rigged truck crane (supported and rigged with counterweight). If the truck crane is not yet rigged; **▶▶▶ CHECKLIST: Rigging, p. 12 - 1.**

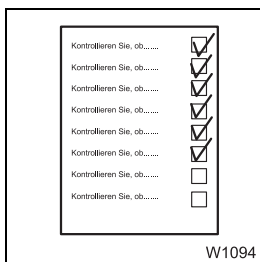

1. The truck crane has been rigged for the operation to be carried out as described in the *CHECKLIST: Rigging*; **▶▶▶ p. 12 - 1.**

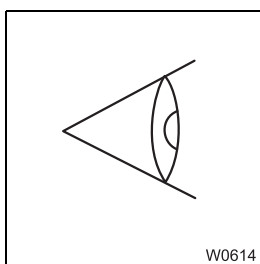

2. Carry out an inspection of the truck crane, looking out in particular for any leaking fluids (oil, fuel or water).

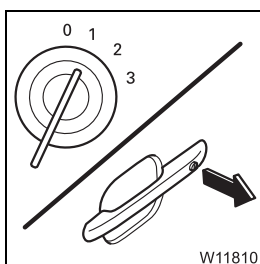

3. If you intend to drive from the crane cab:
– In the driver's cab, turn the ignition key to position **1** and
– secure the truck crane against unauthorized use.

30.06.2014



Seat contact switch



This check is carried out together with the dead man's switch.

Danger of accident if the seat contact switch is faulty

Always stand inside the crane cab when you do this check.

If you stand next to the crane cab, you may be pushed off the carrier if the superstructure slews as a result of a faulty dead man's switch.

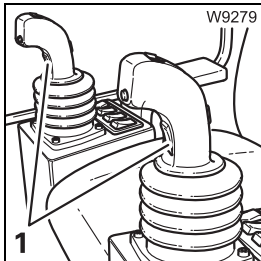

Checks while stationary

- Do not sit down on the crane cab seat.
- Do not press any dead man's switch (1).
- Move the control levers one after the other for all the crane movements and check whether all the crane movements are switched off.

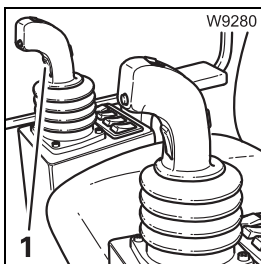

Checks during operation

– Dead man's switch

- Do not sit down on the crane cab seat.
- Press the right dead man's switch (1) and slowly lift the hook block.
- With the control lever actuated, let go of the right dead man's switch and check whether the crane movement comes to a standstill within approx. 3 seconds.
- Repeat the check with the dead man's switch on the left control lever.

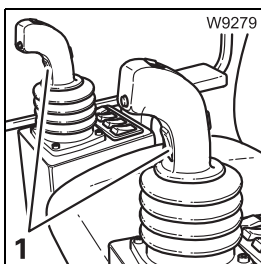

– Seat contact switch

- Do not press any dead man's switch (1).
- Sit down on the crane cab seat and slowly lift the hook block.
- With the control lever actuated, stand up and check whether the crane movement comes to a standstill within approx. 3 seconds.

If the dead man's switch system is not working correctly, do not start work with the crane but notify **Manitowoc Crane Care**.

11.2.2 Enter rigging mode

For a complete rigging mode input, you must enter, confirm and accept the rigging mode and the reeving.

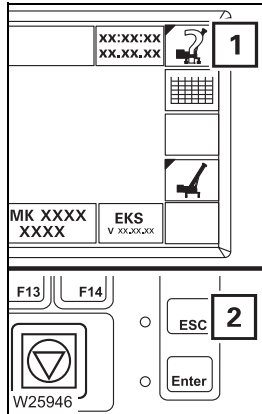

Opening the submenu

- If necessary, open the main menu (2) and press the button (1) once.

The button (2) is only active if all crane movements have been stopped.

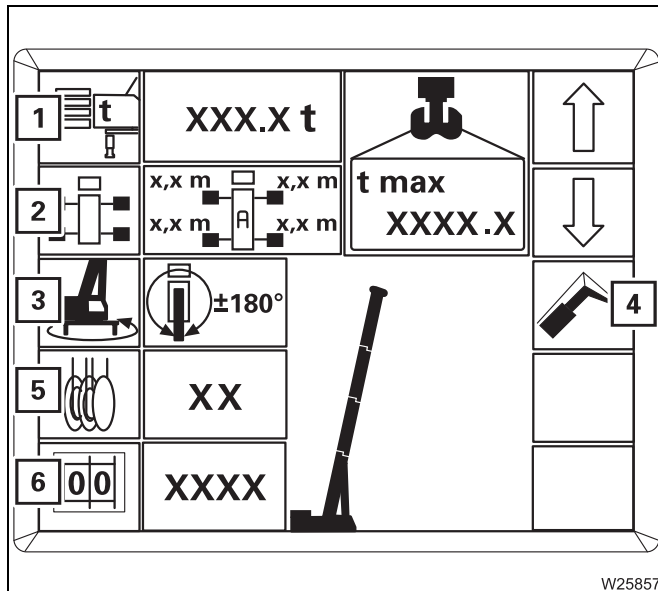

The *Enter rigging mode* submenu opens.

There are two ways of entering the current rigging mode.

- **Either** enter the individual components (1) to (4) one after the other.
- **Or** enter the RCL code (6) and the reeving (5).

Then you must confirm and accept the newly entered rigging mode.

The following section describes the input procedure based on the individual components. If you want to enter the rigging mode based on the RCL code;
 *Entering the RCL code*, p. 11 - 26.



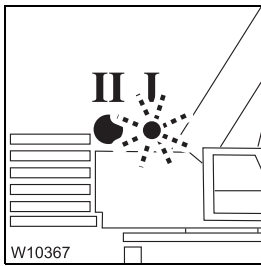

Example of how to switch over the display

The load should be raised with the main hoist, for example. However, lamp **II** for the auxiliary hoist lights up and lamp **I** for the main hoist flashes.

Switch over the display as follows:

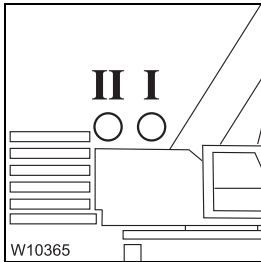

- Switch off both hoists. The lamps **I** and **II** go out.

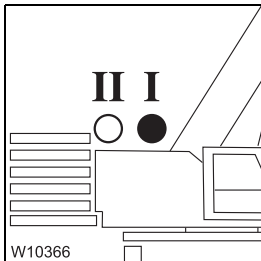

- Switch on the main hoist.
- Now the lamp **I** for the main hoist is on.

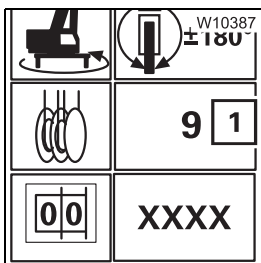

The display **(1)** shows the last entered reeving value for the main hoist, e.g. **9**.

If no reeving has been entered yet, the RCL selects reeving **1**.

- If necessary, enter the current reeving; p. 11 - 27.



Risk of accidents due to incorrectly set RCL.

After switching over the hoists, always check whether the displayed reeving value corresponds to the current reeving value of the displayed hoist and, if necessary, enter the current reeving value.

In this way, you can prevent the RCL from making calculations based on an incorrect reeving value and the truck crane from becoming overloaded or from overturning.

11.2.9

RCL override – version B

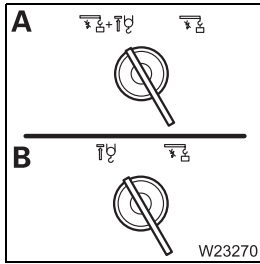

This section only applies to the key-operated switch with the symbol (B). If the symbol (A) is present; *RCL override – version A*, p. 11 - 39.

If the RCL is overridden, the crane operation is not monitored and the switched off crane movements are enabled again. Once the RCL is switched off, there are three options for overriding:

- **During rigging**, you can override the RCL shutdown or the lifting limit switch for rigging work; *When rigging*, p. 11 - 42.
- **You can release the raise boom function to leave the shutdown area**; *To raise the boom*, p. 11 - 43.
- **In the event of an emergency** you can override the RCL shutdown completely; *In emergencies*, p. 11 - 44.

Overview status display

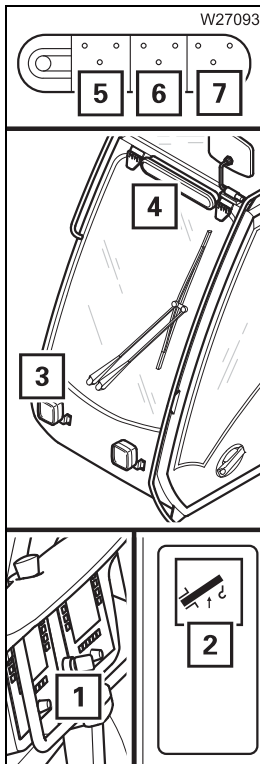

The lamps (5) to (7) of the status display (4) light up or flash depending on the RCL degree of utilisation and button confirmations.

Switch pressed	Degree of utilisation		
	0 - 90%	Approx. 90 - 100%	Greater than 100%
No switch (normal operation)	Display (5) green	Display (6) yellow	Display (7) red
Key-operated switch (1) override for rigging	Display (5) green	Display (6) yellow	Display (6) yellow, flashing
Button (2) Raising	Display (5) green	Display (6) yellow	Display (5) green, flashing
Key-operated switch (3) RCL override in an emergency	Display (7) red, flashing	Display (7) red, flashing	Display (7) red, flashing





11.3.2



Permissible slewing ranges and working positions

The following ranges are permissible for crane operation according to the *Lifting capacity table*:

360° slewing range



- Support the truck crane with the outrigger span required according to the *Lifting capacity table*.
- Enter an RCL code for the 360° slewing range according to the *Lifting capacity table*;  Enter rigging mode, p. 11 - 21.
- Rig a counterweight combination that is no larger than that permitted for the rigged outrigger span. Slewing with a rigged counterweight is not permitted with all outrigger spans;  *Slewing with rigged counterweight*, p. 12 - 90.
- Slewing is not permissible if the truck crane is free-on-wheels;  *Free-on-wheels working position*, p. 11 - 52.

0° to the rear working position

- Support the truck crane with the outrigger span required according to the *Lifting capacity table*.
- Slew the superstructure to the rear into the 0° position.
- Switch off the slewing gear;  p. 11 - 101.
- Enter an RCL code for the 0° to the rear working position according to the *Lifting capacity table*;  Enter rigging mode, p. 11 - 21.
The RCL will only accept this code if the slewing gear has been switched off and the superstructure is in the 0° position.



All slewing operations are disabled if an RCL code is entered for the 0° to the rear working position. An RCL shutdown will be triggered if you switch on the slewing gear. To acknowledge the shutdown, you must:

- Either shut down the slewing gear
- or, if slewing is permissible with the rigged counterweight ( p. 12 - 90), set down the load and enter an RCL code for the 360° slewing range.
- Observe the additional information if the truck crane is free on wheels;  *Free-on-wheels working position*, p. 11 - 52.



11.3.5

Lifting limit switch, lowering limit switch, height contact switch

Lifting limit switch

To install/remove the lifting limit switch;  p. 12 - 111.

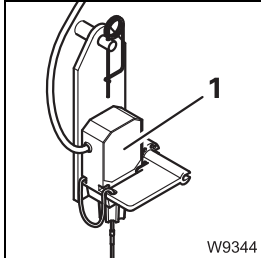

The lifting limit switch (1) prevents the hook block from being lifted up to the main boom head and damaging it.

The lifting limit switch only works if it has been unlocked;  p. 12 - 116.



Risk of accident due to intentionally triggering the lifting limit switch

Always complete the hoisting operation (and extending) before raising the lifting limit switch weight. If the lifting limit switch is lifted at too great a speed, the hook block may swing into the main boom head and damage the head sheaves and the hoist rope.

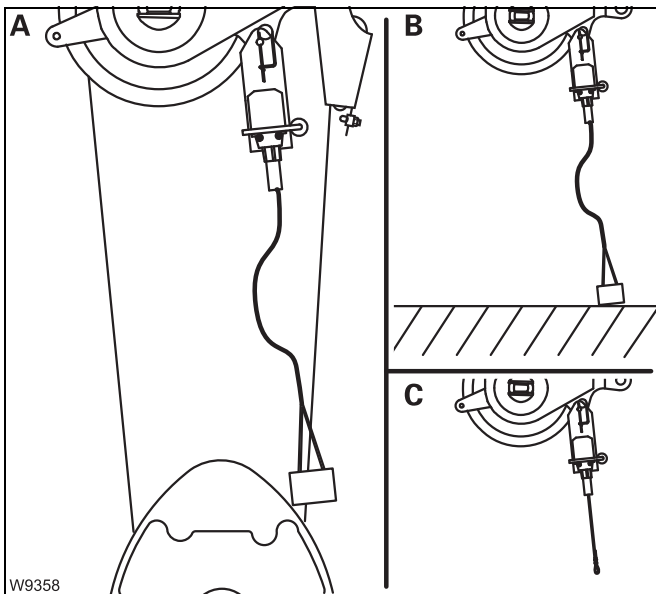

The lifting limit switch will be triggered if:

(A) – the hook block raises the lifting limit switch weight or

(B) – the lifting limit switch weight touches the ground upon lowering or

(C) – the lifting limit switch weight is not attached.

The lifting limit switch will not trigger if it is locked.

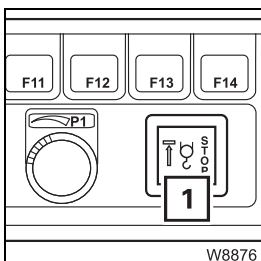

The lamp (1) will light up if the lifting limit switch has been triggered. At the same time, all movements which would increase the load moment will be switched off – *Lifting, Lowering, Extending* and *Derricking the lattice extension* if necessary.

To cancel the shutdown, leave the shutdown range by performing a different crane movement or by setting down the load.



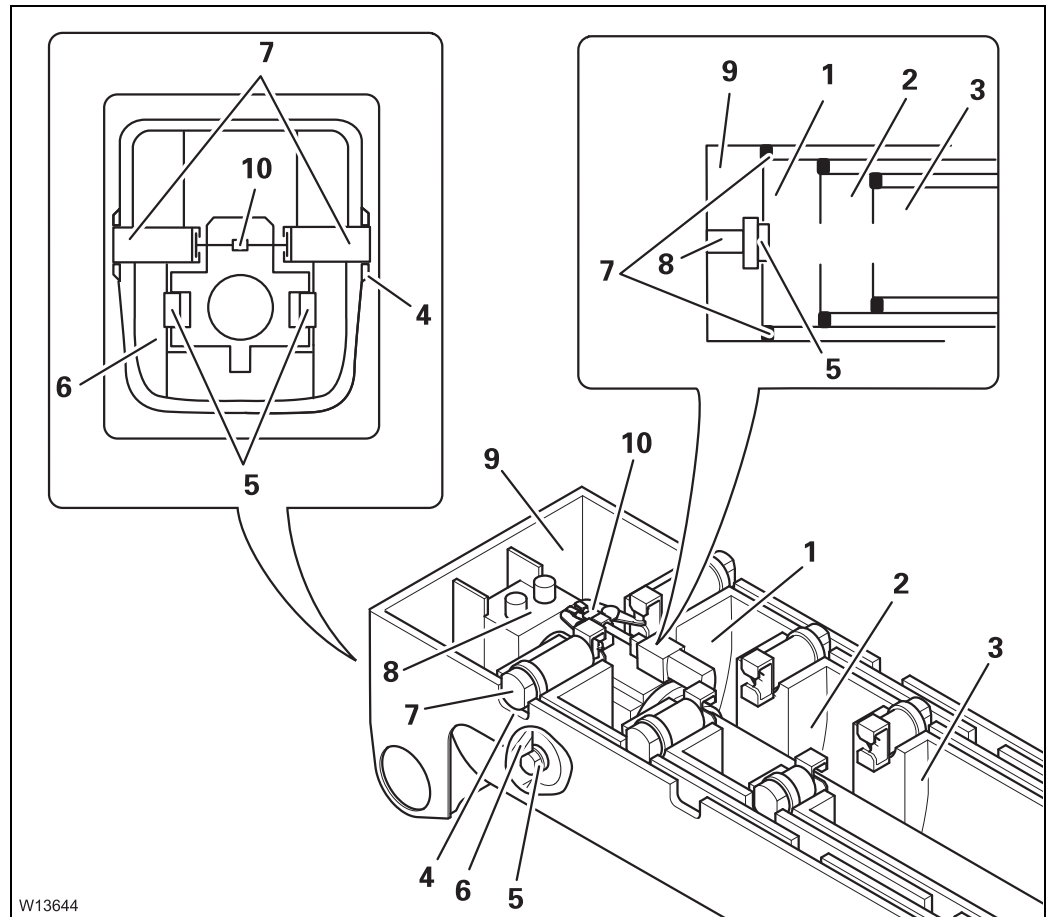

- 1** Telescopic section I
- 2** Telescopic section II
- 3** Telescopic section III
- 4** Cutouts
- 5** Locking pins on the telescoping cylinder
- 6** Cutouts
- 7** Locking pin on the telescopic section
- 8** Telescoping cylinder (piston rod)
- 9** Basic section
- 10** Mechanism



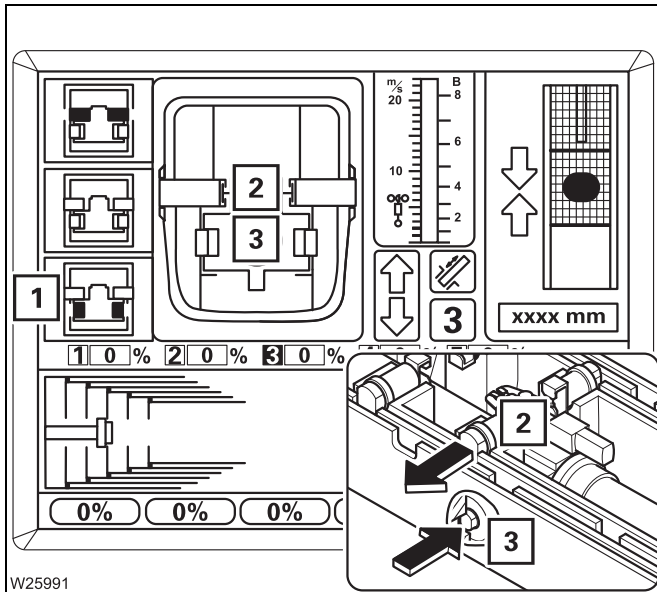

Unlocking the telescoping cylinder

- Move the control lever for telescoping.

If required, extend the locking pins (2) first.

The locking pins (3) retract.

– **Yellow:** Intermediate position

– **Red:** Unlocked

In the *Unlocked* position, symbol (1) will be yellow.

If the control lever is moved, the telescoping cylinder will move immediately.

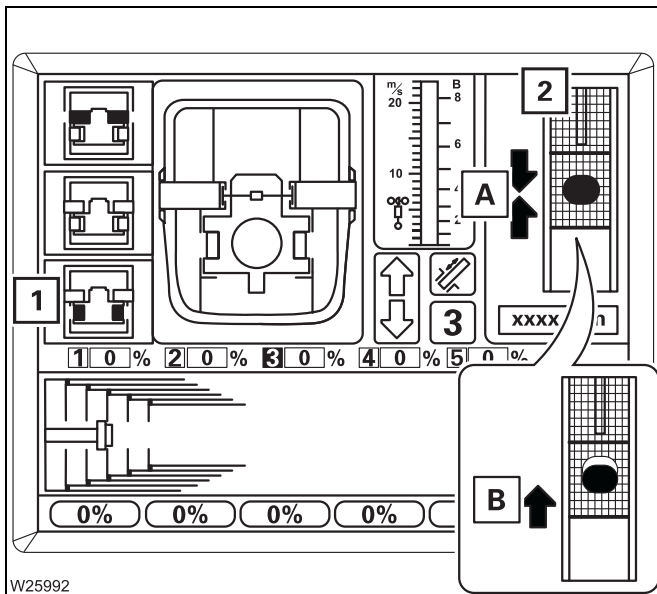

If symbol (1) is still flashing after approx. 10 seconds, this means that the locking pins are under load.

- Release the control lever.

The display (2) shows which movement you need to carry out to take the load off:

– **A:** Retracting

– **B:** Extend



Risk of damage to the boom system.

If extending and retracting several times does not lead to the lock being released, you must not telescope any further against the stop.

If removing the load does not cause the lock to be released, you must lock the telescoping cylinder (p. 11 - 83) and then restart unlocking.



Example of telescoping with teleautomation

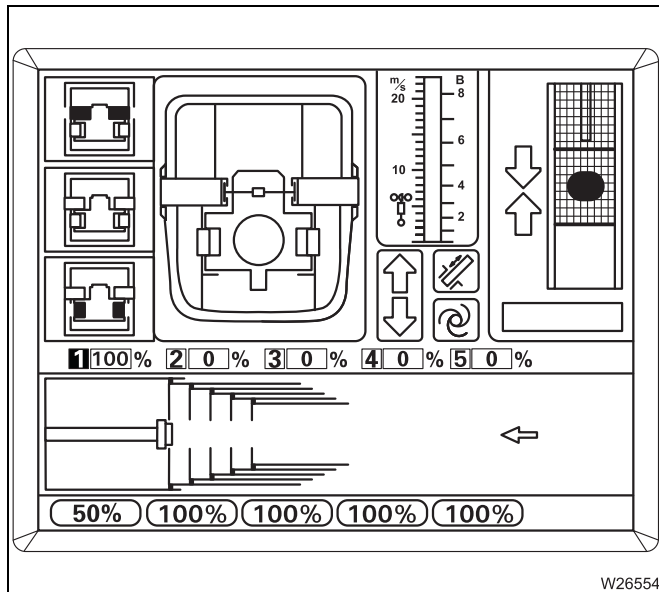

Assuming the current telescoping is 100/0/0/0/0/0 and the telescoping cylinder is locked in telescopic section I.

The desired telescoping is 100/50/100/100/100/100.

The display should correspond to the opposite diagram once you have entered the desired telescope status and confirmed it.

ECOS will calculate the following telescoping sequence:

- | | | |
|--------------------------|---------|---------|
| – Telescopic section I | retract | to 0% |
| – Telescopic section V | extend | to 100% |
| – Telescopic section IV | extend | to 100% |
| – Telescopic section III | extend | to 100% |
| – Telescopic section II | extend | to 100% |
| – Telescopic section I | extend | to 50% |

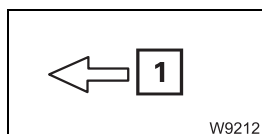

Since the first step is retracting, arrow (1) points to the left.

- Move the control lever to retract and hold it.

Telescopic section I is fully retracted. The following processes are carried out automatically for this.



Switching off the slewing gear

If the slewing gear is not required, it should be switched off to avoid unintentional use.

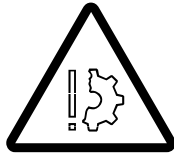

Risk of damage to the main boom

Brake the slewing movement down to a standstill before you switch off the slewing gear. The slewing gear brake is automatically engaged when the slewing gear is switched off.

This prevents lateral forces from affecting the main boom due to long delays or swinging loads.

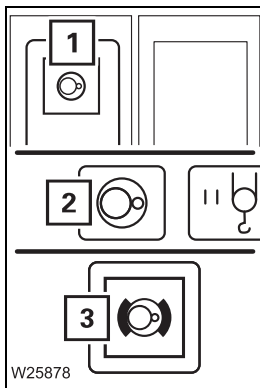

- Press the button (1) once.
 - The lamp in the button (1) will light up dimly.
 - Symbol (2) will be **red** if the slewing gear is switched off.
 - The slewing gear brake is engaged – lamp (3) lights up.

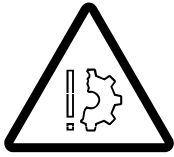

Risk of damage if warning messages are not observed!

Observe the following information in good time and take the appropriate remedial measures if a warning message appears. This prevents these malfunctions from causing malfunctions in the truck crane.

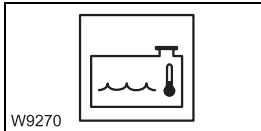

Coolant too hot

The coolant in the engine is hotter than approx. 95 °C.
Current temperature display; p. 10 - 17.
Possible cause and solution; p. 14 - 24.

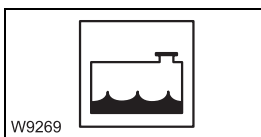

Coolant level too low

- Immediately top up the coolant so that the engine does not overheat;
 Maintenance manual.



Oil pressure too low

A warning buzzer sounds at the same time.

- Set down the load as soon as possible and turn off the engine.
- Check the oil level; *Maintenance manual*.
- Add oil if necessary. If the error message persists, refer to **Manitowoc Crane Care**.



Risk of damage to the engine if the oil pressure drops

Turn off the engine as soon as possible and look for the cause if the lamp lights up or the warning buzzer sounds.
Never restart the engine before you have found the cause and eliminated the problem. p. 14 - 13, p. 7 - 23

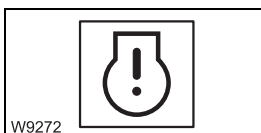

Engine electronic system

Malfunction in the engine electronics:

- Superstructure; p. 14 - 13
- Carrier – switch off engine immediately; *Messages on the on-board computer display*, p. 5 - 54.



11.5.3 Entering limit values

This section describes how to enter unknown limit values by moving to the shutdown points.

You can enter known limit values directly; *Entering limit values/objects manually*, p. 11 - 127.

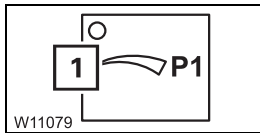

Prerequisite

Manual input must be switched off.

- Press button (1) repeatedly until the dot turns **black**.



Risk of accident due to limits set too low

When entering the limits, bear in mind that, even after switching off the engine, movements can still occur that would bring the load into the shutdown range, e.g. due to the load swinging or the boom bending. For this reason, always enter the limit values with sufficient safety distance to the object.

Overall height/ working radius

The limit values for the overall height and the working radius are entered in the same way.

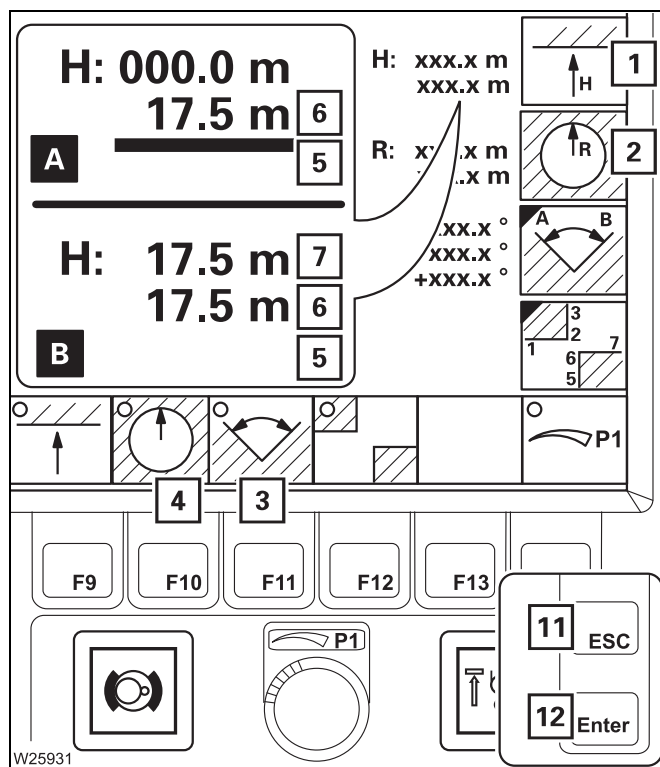

The relevant monitoring function (3) or (4) must be switched off – dot is **black**; p. 11 - 129.

- Press the button once:
 - 1 For the overall height
 - 2 For the working radius.
- Bar (5) is red – input on. To cancel input – press button (11) once.
- (A) – Move the main boom head without a load to just before the shutdown point, e.g. at 17.5 m – value (6).
- (B) – Press the button (12) once.
 - The current value (6) will be accepted as the limit value (7).
 - The bar (5) goes out.
- Switch on monitoring; p. 11 - 129.



11.6

Work break

11.6.1

In case of short work breaks



Risk of accidents due to suspended loads

Never turn off the engine with a load suspended. You must have the control levers at hand in order to intervene at any time.

Always set down the load before you leave the crane cab.

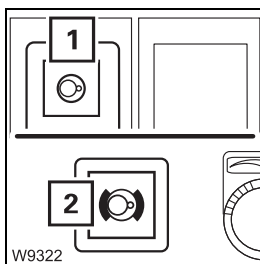

- Switch off the slewing gear.
 - The lamp in the button (1) must be dimly lit.
 - Lamp (2) must light up – slewing gear brake engaged.

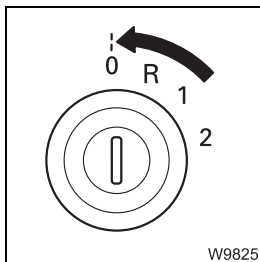

Switch the engine off, turn the ignition key to position **0** and remove it.

Ensure that no unauthorised persons can operate the truck crane;

➡ *To secure the truck crane, p. 11 - 132.*

Switching on

- Check whether the auxiliary heater is allowed to be operated at the current site of the truck crane before switching it on. Find out whether there are any possible sources of danger that could result in an explosion.



Risk of explosion when operating the auxiliary heater

The auxiliary heater is not allowed to be operated:

- At service stations and tank farms
- At places where flammable gases or vapours can be found or formed (e.g. at places where fuel is stored and in chemical factories)
- At places where explosive dust can be found or formed (e.g. coal dust, wood dust and grain dust).



Danger of suffocation when operating the auxiliary heater

Do not use the auxiliary heater in closed spaces (e.g. a garage).



This section describes how to switch on the heater manually. The auxiliary heater can also be switched on automatically;  *Storing the heating start*, p. 11 - 143.

- Turn on the ignition;  *Switching on the ignition*, p. 10 - 10.

- Press the button (1) once.

The auxiliary heater switches on automatically – the control field lights up.

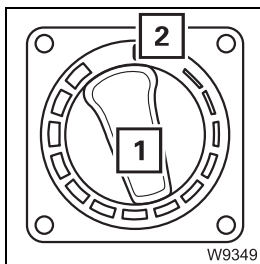
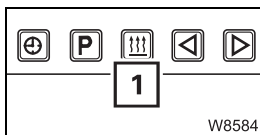

Setting the temperature

- Turn switch (1) to the desired temperature.

If the switch (1) is turned as far as possible (2) (*Cold*), the auxiliary heater is not switched on.

The auxiliary heater only supports the heating capacity of the standard heating system as long as the engine is cold. If the engine is warm, the heater is switched off. However, the pump for the auxiliary heater continues to run until you switch the auxiliary heater off.



Always switch off the auxiliary heater when you turn off the truck crane when the battery master switch is switched on. In this way, you prevent the auxiliary heater from restarting and the batteries from running down after the engine has cooled down.



12 Rigging work

12.1	Rigging work checklists for crane operation with the main boom	12 - 1
12.1.1	CHECKLIST: Rigging	12 - 1
12.1.2	CHECKLIST: Unrigging	12 - 7
12.2	Choosing a suitable site	12 - 11
12.2.1	Determining the required ground bearing area	12 - 11
12.2.2	Safe distance from slopes and pits	12 - 14
12.2.3	Earthing the truck crane	12 - 15
12.2.4	Safe distance from electrical cables	12 - 16
12.3	Rigging work after driving with a trailer	12 - 19
12.3.1	Switching off the boom floating position	12 - 19
12.3.2	Switching off the slewing gear freewheel	12 - 20
12.3.3	Switching off boom pre-tensioning	12 - 21
12.4	Connecting/disconnecting the hand-held control	12 - 23
12.5	Starting the engine for driving for rigging work	12 - 25
12.5.1	Starting/turning off the engine with the hand-held control	12 - 25
12.5.2	Starting/turning off the engine from the crane cab	12 - 27
12.6	Outrigger	12 - 29
12.6.1	CHECKLIST: Extending the outriggers	12 - 29
12.6.2	CHECKLIST: Retracting the outriggers	12 - 31
12.6.3	Permissible outrigger spans	12 - 32
12.6.4	Preparing the truck crane	12 - 33
12.6.5	Setting the outrigger spans	12 - 34
12.6.6	Extending/retracting outrigger beams	12 - 36
12.6.7	Moving the outrigger pads into working/driving position	12 - 41
12.6.8	Enlarging the ground bearing area	12 - 42
12.6.9	Extending/retracting supporting cylinders	12 - 43
12.6.10	Level the truck crane on outriggers	12 - 48
12.6.11	Levelling the free-on-wheels truck crane	12 - 53
12.6.12	Outrigger pressure display	12 - 55



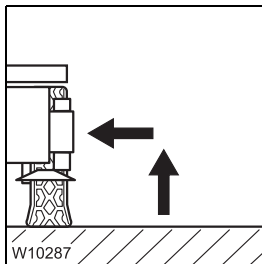

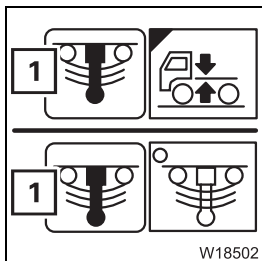

- 12.** Retracting the outriggers;  *CHECKLIST: Retracting the outriggers*, p. 12 - 31.

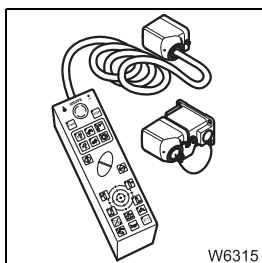

- 13.** Activate the suspensions (release locking).
The symbol (1) must be **green** (suspension on);  p. 5 - 15.



- 14.** Turn off the engine and, if necessary, remove the hand-held control and stow it away in the driver's cab;  *Disconnecting the hand-held control*, p. 12 - 23.

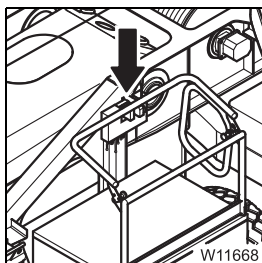

- 15.** Fold in the tread grid on the turntable;  p. 12 - 123.

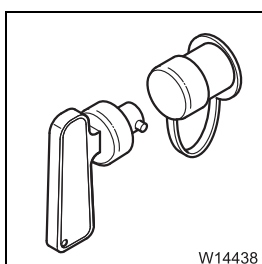



- 16.** When the truck crane is no longer being used;  *In case of work breaks of more than 8 hours*, p. 11 - 132.

12.3

Rigging work after driving with a trailer

If the main boom was resting on a trailer (dolly) while driving the truck crane, you must perform the following before working with the crane:

- Switch off the slewing gear freewheel;  p. 12 - 20,
- Switch off the boom floating position;  p. 12 - 19,
- Switch off boom pre-tensioning, if necessary;  p. 12 - 21.

12.3.1

Switching off the boom floating position

You must switch off the boom floating position before you raise the main boom off the trailer.



Risk of accident from the main boom falling down

Always secure the lever with the padlock after switching off the boom floating position.

This prevents the raised main boom from falling down when actuating the lever.

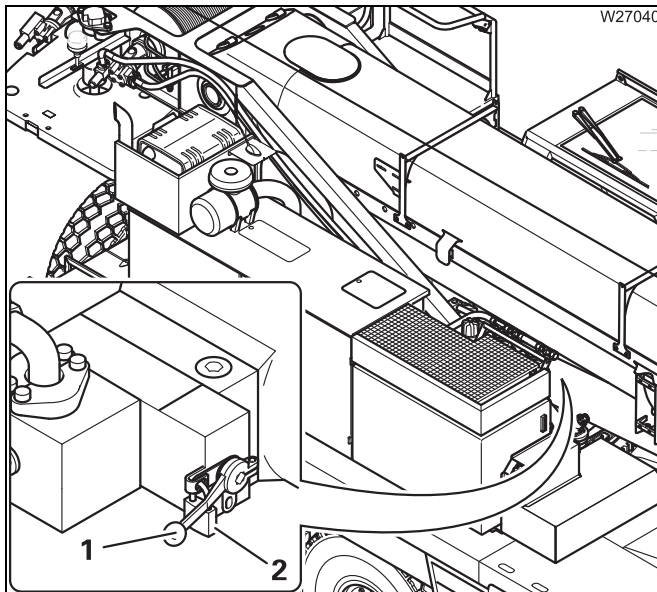

- Remove the padlock (2).
- Switch the valve I over – lever (1) positioned vertically pointing outwards or inwards, depending on its fitting position.
- Secure the lever (1) with the padlock (2).

The boom floating position is now switched off.

12.6

Outrigger



Danger of crushing from extending outrigger beams.

You may only activate the outriggers if you yourself or a banksman with whom you are in visual contact have an unobstructed view of their movements.

12.6.1

CHECKLIST: Extending the outriggers



This checklist is not a complete operating manual. There are accompanying operating instructions which are indicated by cross-references.

Observe the warnings and safety instructions specified here.

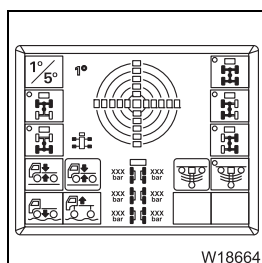

1. Level the truck crane with the level adjustment system and lower it as far as possible; p. 5 - 69.

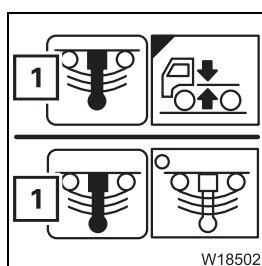

2. Switch off (lock) the suspension.
The symbol (1) must be **red** (suspension off); p. 5 - 15.

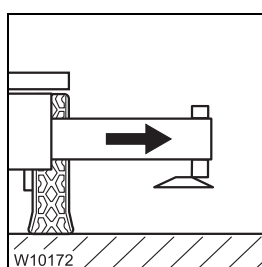

3. Extend all outrigger beams to the required span;
 - Permissible outrigger spans*, p. 12 - 32,
 - Setting the outrigger spans*, p. 12 - 34,
 - Extending/retracting outrigger beams*, p. 12 - 36.

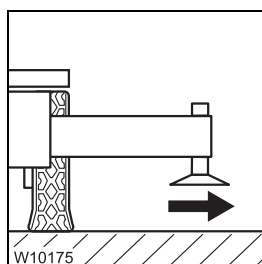

4. Move the outrigger pads into the working position and secure them; p. 12 - 41.



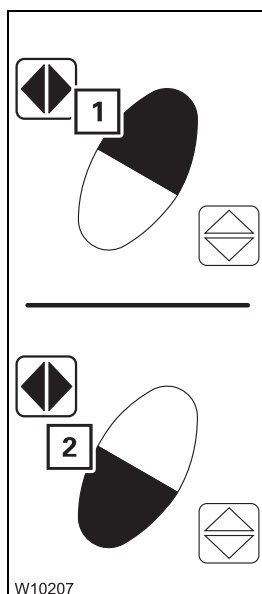

Extending/retracting outrigger beams

- Observe the safety instructions for operating the outrigger beams;
 p. 12 - 36.
- Press the button combination for the desired movement:
 - 1 Extend
 - 2 Retract

The pre-selected outriggers move until you let go of the respective button or until the respective end position has been reached.

From the crane cab

The following operating elements are found in the *Outriggers* submenu.

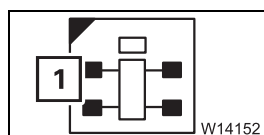

Opening the submenu

- In the main menu, press button (1) once.
 The *Outriggers* submenu opens.

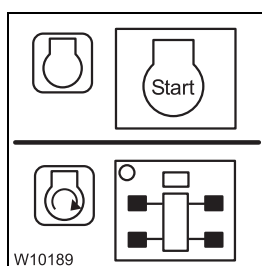

Start the engine

- Switch the carrier ignition on and start the engine for driving;
 p. 12 - 27.
- Switch off the slewing gear.

Pre-selecting outriggers



Only pre-select one outrigger. If you pre-select several outriggers, operation of the outriggers is not enabled.



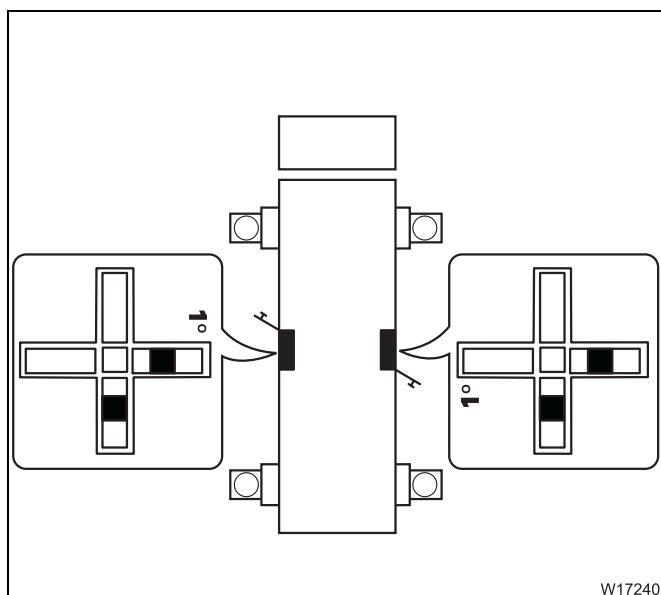

– *Outrigger* control units

The assignment to the carrier corresponds to the top view.

Due to the position of the control units, the displays on both sides differ.

In this example, the carrier would be standing higher to the rear on the right hand side.

Prerequisites

The following prerequisites apply to manual and automatic alignment.

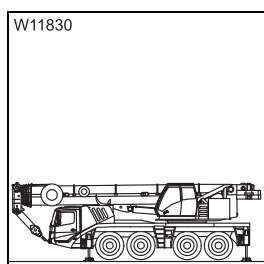

The main boom must be resting on the boom rest.

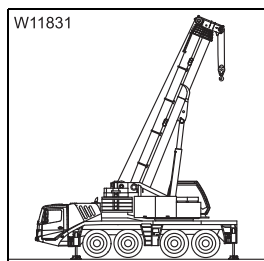

Or

- The main boom must be raised **and**
- the load has been set down **and**
- the superstructure is in the 0° or 180° position.



Risk of overloading the main boom!

Always slew the superstructure to the 0° or 180° position and set down the load before levelling the truck crane.

In other positions, the deformation of the carrier will distort the indicated inclination and the truck crane will be at an angle. This could cause the outrigger beam to become overloaded during crane operation.



12.7.2

Identification

The truck crane and its corresponding counterweight sections are labelled with the same serial number.

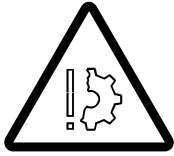

Danger if counterweight sections are interchanged

Use only counterweight parts that belong to your truck crane. The truck crane and counterweight sections are labelled with the same serial number. Other or additional counterweight sections may not be rigged.

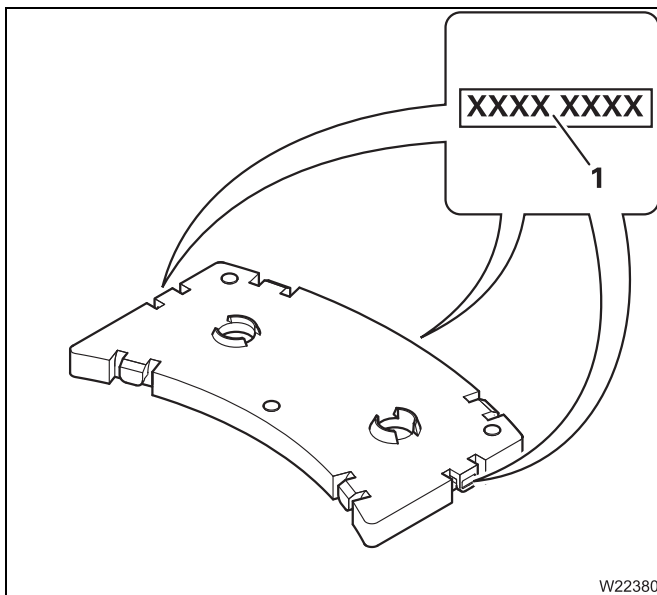

The serial number (1) of all plates is either on the back or indicated together with the weight.

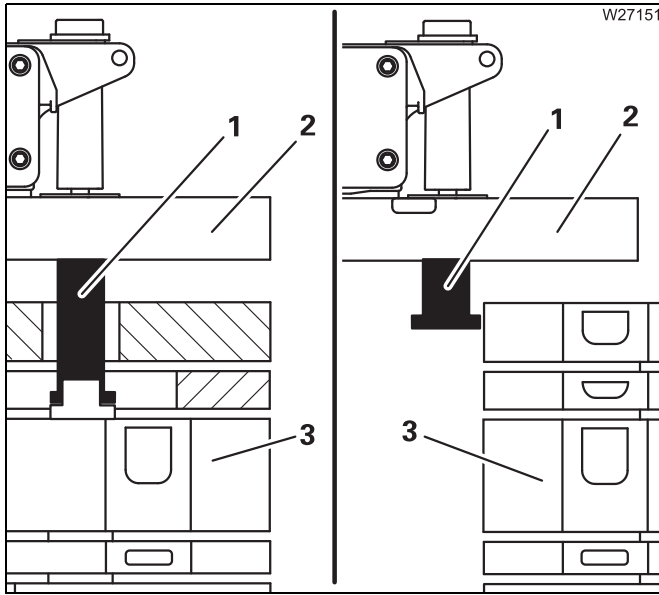

Before assembling

- 26.1 t or
- 23.9 t with the 3.3 t plates (3)

the 4.4 t plate (2) must always be mounted on the turntable;  p. 12 - 84.

Otherwise, the lifting cylinders (1) will knock against the counterweight which has been stacked too high during rigging.



Risk of damage to the lifting cylinders!

If necessary, mount the 4.4 t plate on the turntable, so that the lifting cylinders do not knock against the assembled counterweight while slewing.

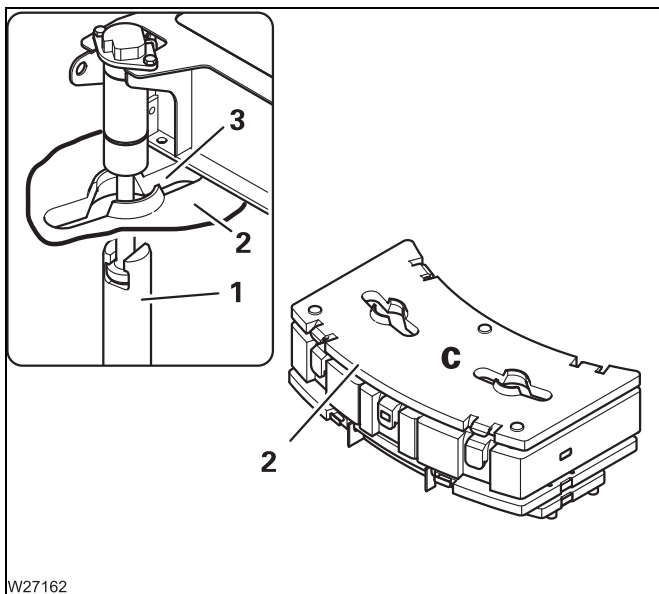

To ensure that the lifting cylinders can rotate within the cutouts (3) in the 2.2 t base plate (1), with counterweight values of 23.9 t and 26.1 t the 2.2 t plate (2) must lie on top.



Extending/ retracting the lifting cylinders

This section describes how to operate the lifting cylinders manually,
– for correcting the displayed rigging mode and
– for pre-charging the counterweight afterwards.



Always lift and lower the counterweight in automatic mode, otherwise slewing with extended lifting cylinders will be blocked; *Automatic mode rigging*, p. 12 - 80, *Automatic mode unrigging*, p. 12 - 81.

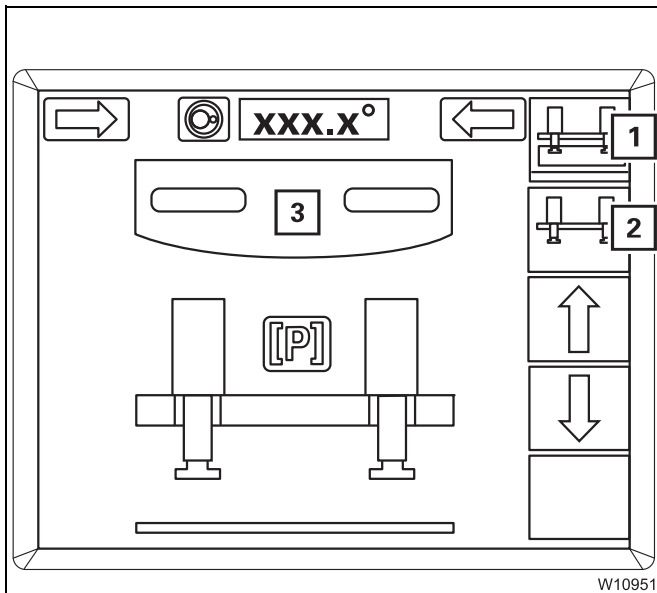

Correct the rigging mode

- You can use the automatic mode only if the current rigging mode is displayed.
 - Yellow – counterweight rigged
 - Yellow – counterweight unrigged

If necessary, correct the displayed rigging mode as follows:

- Slew the superstructure out of the rigging range – display (3) – so that the lifting cylinders can be freely extended.

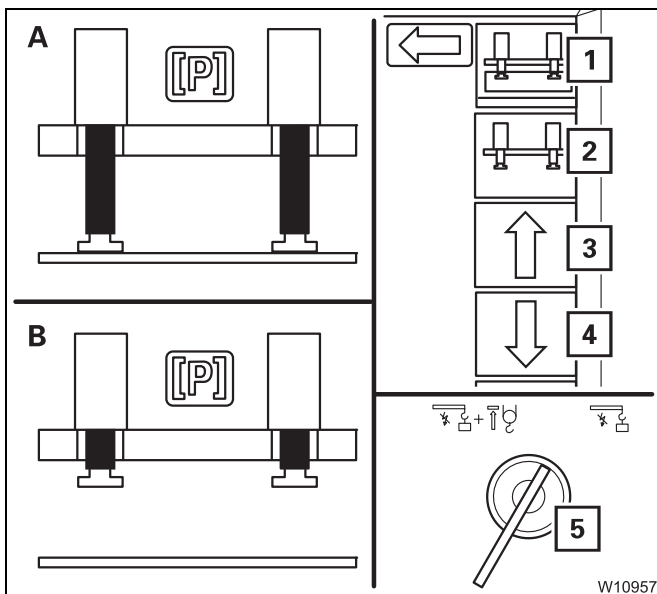

Assuming the symbol (1) is yellow with the counterweight unrigged.

- Turn the key-operated switch (5) to the right.
- (A) – Fully extend the lifting cylinders – button (4).
- Let go of the key-operated switch (5).
- (B) – Fully retract the lifting cylinders – button (3).

The symbol (2) turns yellow – counterweight unrigged.

You can now use the automatic mode.



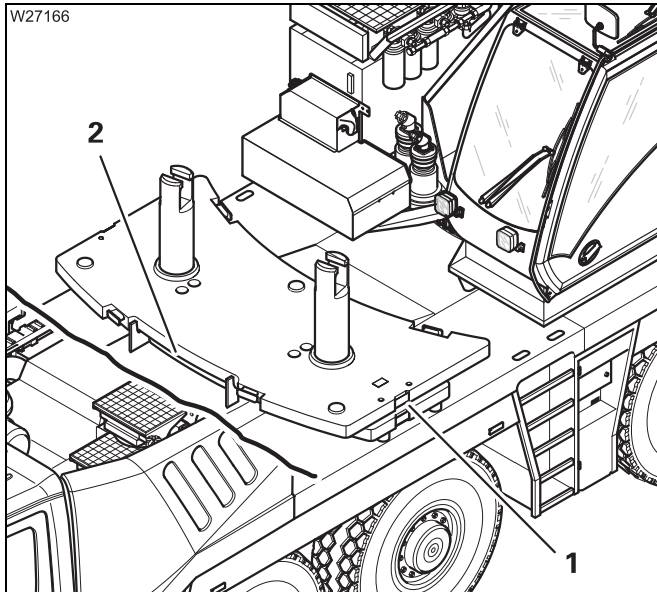

With version C

- For version 2 (||||▶ p. 12 - 66)

If a 2.2 t plate needs to be set down on the 2.2 t base plate (1) then only the 2.2 t plate **with cutout** (2) may be set down on the 2.2 t base plate.

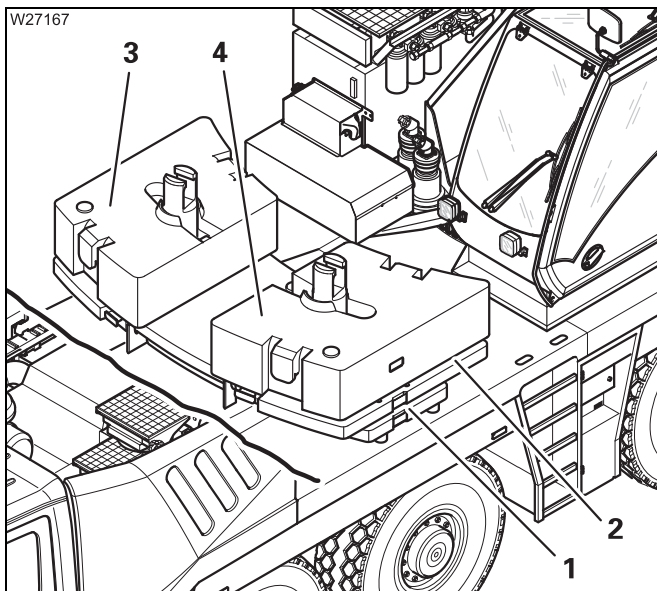

- At most, set down
 - the 2.2 t base plate (1),
 - one 2.2 t plate (2) and
 - the 3.3 t plates (3) and (4).

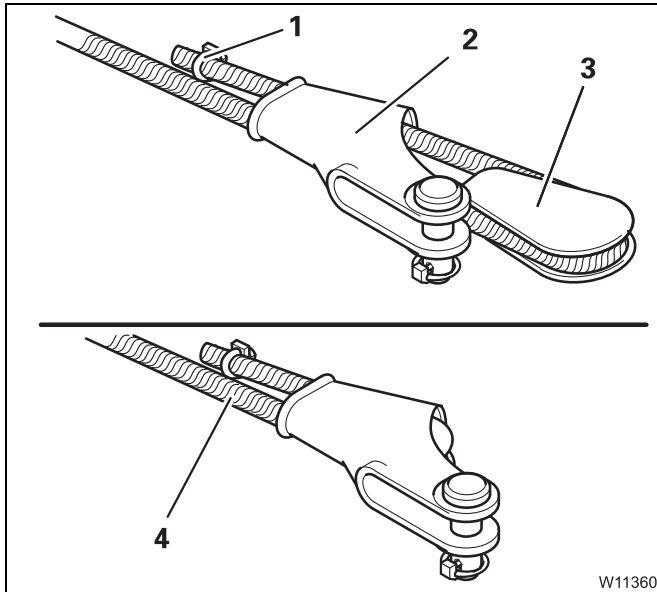

- Observe the correct rope guide!
- Insert the hoist rope with the corresponding rope wedge (3) into the rope end clamp (2).
- Fasten the rope clamp (1) to the loose end of the hoist rope.
- Pull the hoist rope (4) taut until the rope wedge and the hoist rope sit tightly in the rope end clamp.

Reeving the hoist rope

Reeving is also possible when the rope end clamp is fastened.



Danger due to slack rope

Only use hook blocks and sling gear of the minimum weight prescribed in the *Lifting capacity table*, depending on the reeving and boom length. This prevents slack rope forming at large heights when lifting without a load. This can result in the load slipping.



This section is only applicable for standard hook blocks. To reeve the hoist rope on a hook block; *Separate engine operating instructions.*

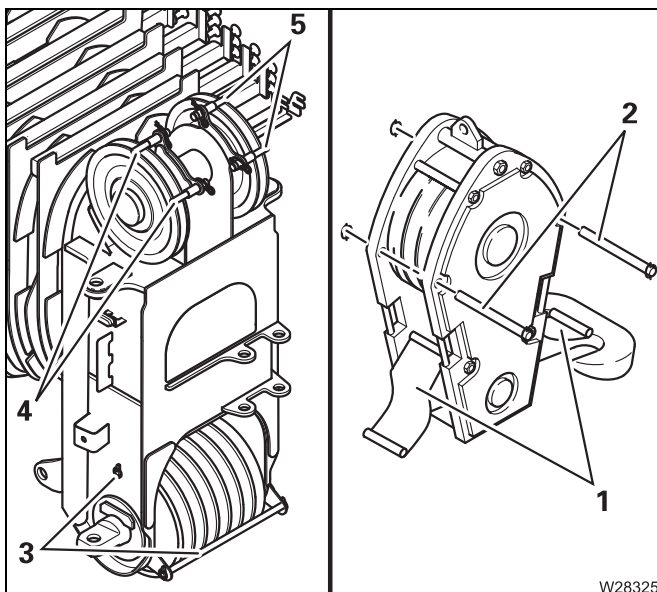

Opening the hook block

- Pull out the rods (2).
- Fold down the plates (1).

Positioning the hoist rope

- Pull out the rods (3).
- Pull out the rods (4) for the **main hoist rope**.
- Pull out the rods (5) for the **auxiliary hoist rope**.



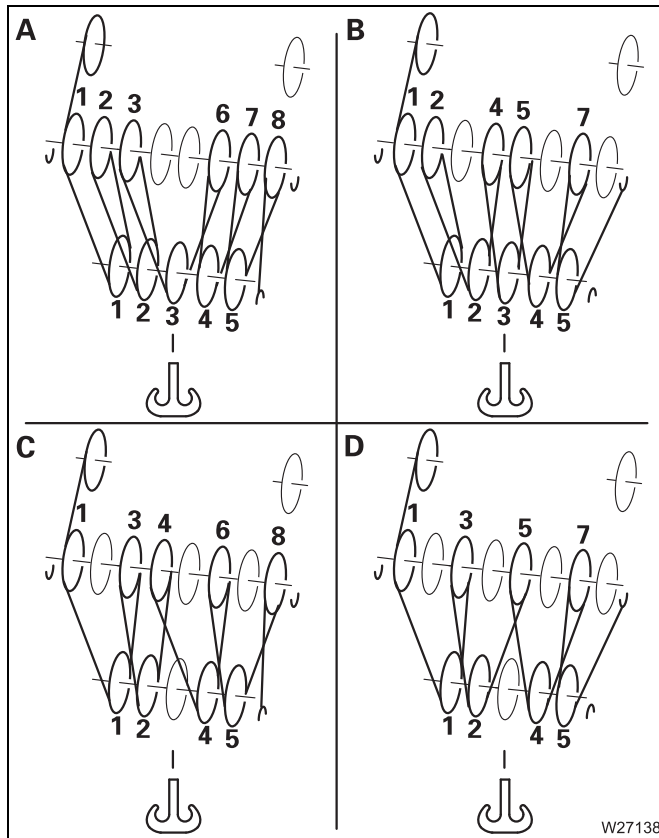

5 sheave hook block

Maximum lifting capacity of the hook block:

63 t

Max. lifting capacity with the GMK 4100

	Reeving	Maximum lifting capacity
A	11 fall	60.9 t
B	10 fall	55.5 t
C	9-way	50.1 t
D	8-way	44.7 t

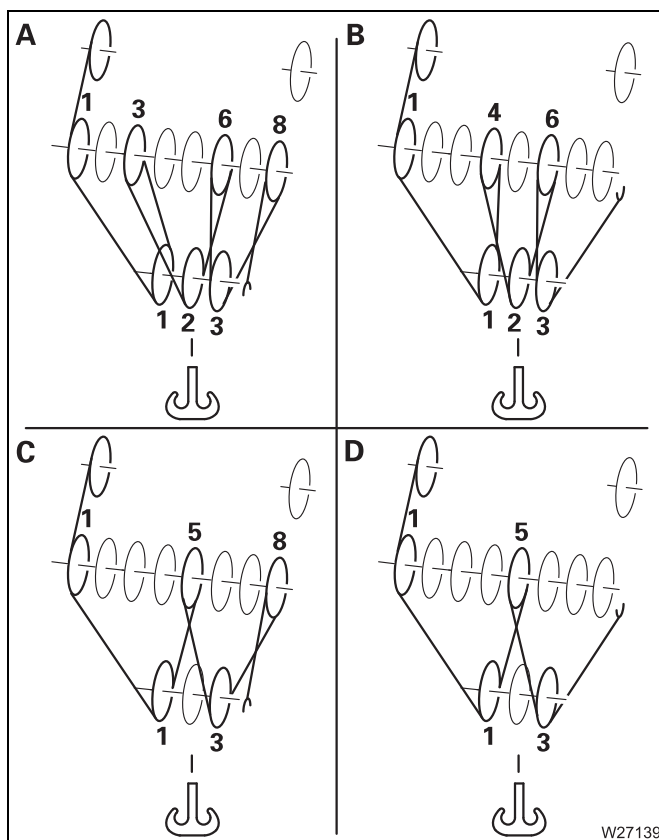

3 sheave hook block

Maximum lifting capacity of the hook block:

40 t

Max. lifting capacity with the GMK 4100

	Reeving	Maximum lifting capacity
A	7 fall	39.2 t
B	6 fall	33.7 t
C	5 fall	28.1 t
D	4 fall	22.5 t



12.9 Other rigging work

12.9.1 Rigging in free on wheels working position

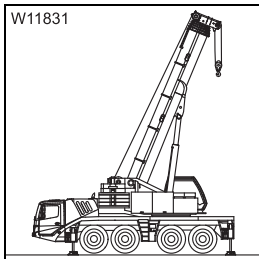

- The truck crane is supported on outriggers.
- The counterweight combination required for using the truck crane free on wheels is rigged.
- Slew the superstructure into the working position 0° to the rear.

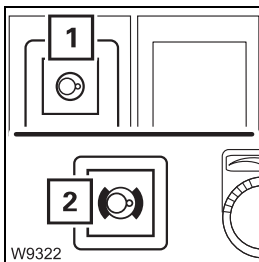

- Switch off the slewing gear so that the slewing gear brake is engaged.
 - The lamp in the button (1) must be dimly lit.
 - The lamp (2) must light up.

➡ Switching off the slewing gear, p. 11 - 101.



Danger of overturning if the supporting cylinders are retracted unevenly!
Retract all of the supporting cylinders as evenly as possible! In this way you can prevent the truck crane from overturning when retracting individual supporting cylinders.

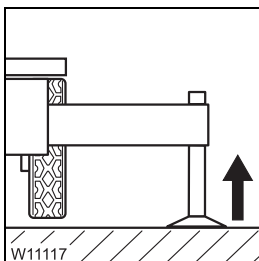

- Retract the supporting cylinders until all wheels are just above the ground.



13 Driving with rigged truck crane

13.1	Safety instructions	13 - 1
13.2	Driving distance	13 - 3
13.3	Before driving the rigged truck crane	13 - 3
13.3.1	Check the tyre pressure and the wind speed	13 - 3
13.4	Permissible rigging modes and axle loads	13 - 5
13.4.1	Axle loads	13 - 5
13.4.2	To drive without a load	13 - 5
13.4.3	To drive with a load	13 - 6
13.5	Driving from the driver's cab	13 - 7
13.5.1	Preparing to drive	13 - 7
13.5.2	While driving	13 - 8
13.6	Driving from the crane cab	13 - 9
13.6.1	Preparing to drive	13 - 9
13.6.2	Opening/closing the Driving mode submenu	13 - 10
13.6.3	Starting/turning off the engine for driving	13 - 13
13.6.4	Steering system	13 - 14
13.6.5	Operating the transmission	13 - 17
13.6.6	Camera system for driving from the crane cab	13 - 19
13.6.7	Starting	13 - 20
13.6.8	While driving	13 - 20
13.6.9	Warning messages	13 - 21
13.6.10	Possible connections	13 - 22
13.6.11	After driving	13 - 24
13.7	Driving in combined operation	13 - 25
13.7.1	Switching combined operation on/off	13 - 25
13.7.2	Starting/turning off the engine	13 - 27
13.7.3	Preparing to drive	13 - 28
13.7.4	While driving	13 - 29

13.6

Driving from the crane cab



Risk of accident when driving with a lifted load!

The truck crane may only be driven with a lifted load when it is in the *Free-on-wheels* working position and if the current rigging mode has been entered on the RCL.



Risk of accidents when an increased idling speed is used!

If necessary, reset the idling speed to the default value. Do not drive with increased idling speed. You may only drive the truck crane from the crane cab at the lowest speed possible.

- Before driving, observe the specifications in sections 13.1 to 13.4.

13.6.1

Preparing to drive

Make sure that the rigging mode for driving with a load or without a load is set correctly;  p. 13 - 5.

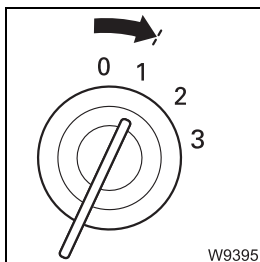

In the driver's cab

- The ignition key is in position **1** so that the steering cannot block.
- The parking brake is engaged.
- The driver's cab is locked with the second ignition key in order to secure it against unauthorized use – e.g. braking.



Risk of accidents if the parking brake is released!

Do not under any circumstances release the parking brake. If the parking brake is released from the driver's cab, it cannot be engaged from the crane cab. In this case, driving from the crane cab is prohibited.

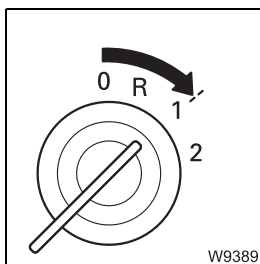

In the crane cab

- The ignition is switched on.
- The hand-held control has been disconnected and bridging plugs have been plugged into all superstructure and carrier sockets.
- The parking brake is engaged.
- The seat contact switch (or a dead man's switch) is actuated.

The engine for crane operation can be switched on or off.

13.6.6

Camera system for driving from the crane cab

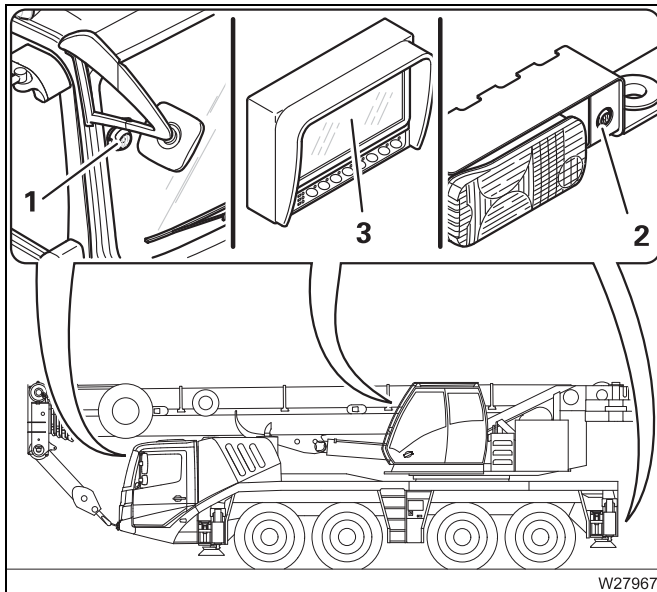

W27967

When driving from the crane cab, the area in front of and behind the truck crane can be displayed via the cameras (1) and (2) on the monitor (3).

A transmitter on the carrier transmits both camera images to two receivers on the superstructure.

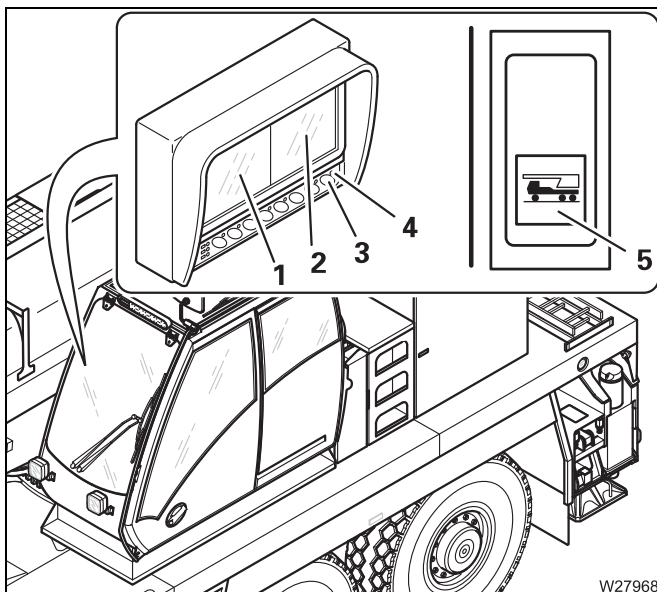

W27968

Switching on

- Turn on the superstructure ignition.
- Switch on the carrier ignition – button (5).
- Press the button (3) once.
The lamp (4) lights up.

The monitor shows the images after a few seconds.

- 1 Image from camera 1 – front area
- 2 Image from camera 2 – rear area

If an image does not appear;  *Malfunctions when driving from the crane cab*, p. 14 - 25.

Align the cameras so that you have a good overview on the monitor.

Switching off

- Press the button (3) once.
The lamp (4) goes out.

13.7.4

While driving



Risk of accidents when the carrier ignition is switched off!

In the crane cab: Do not under any circumstances switch off the carrier ignition. In this way, you prevent the engine for driving from being switched off and the driver in the driver's cab from losing control of the truck crane.



Risk of accidents if the parking brake is released!

In the crane cab: Do not under any circumstances release the parking brake. If the parking brake is released from the crane cab, it cannot be engaged from the driver's cab. In this case, driving from the driver's cab is prohibited.

Without load

- The speed is limited to 8 km/h.
- Only drive slowly, do not change up.
- The turning radius should be as great as possible when driving around corners.
- Only steer the truck crane when it is rolling and avoid sudden steering changes.



Risk of damage to the steering linkage

The steering linkage can be damaged if the steering wheel is moved while the vehicle is stationary.



Danger of overturning by switching on the suspension

The suspension must be deactivated (locked) while the rigged truck crane is on wheels.

When switching on the suspension, the suspension cylinders would suddenly be pressed together and damaged, and the truck crane could overturn.

Never align the truck crane with the level adjustment system if the ground is uneven. In this case you must raise the truck crane with the outrigger cylinders, level it and then re-lower it;  *Levelling the free-on-wheels truck crane*, p. 12 - 53.



Designation	Amperage (A)	Function
F2/1	2	Lifting limit switch
F2/2	20	ESX0 control unit
F2/3	20	ESX1 control unit Slewing gear brake
F2/4	20	Flame start system ¹⁾
F2/5	20	Engine E-control (PLD)
F2/6	3	Emergency operation with hand-held control
F2/7	20	Oil cooler
F2/8	20	Oil cooler ¹⁾

1) Additional equipment

Fuses on the circuit board

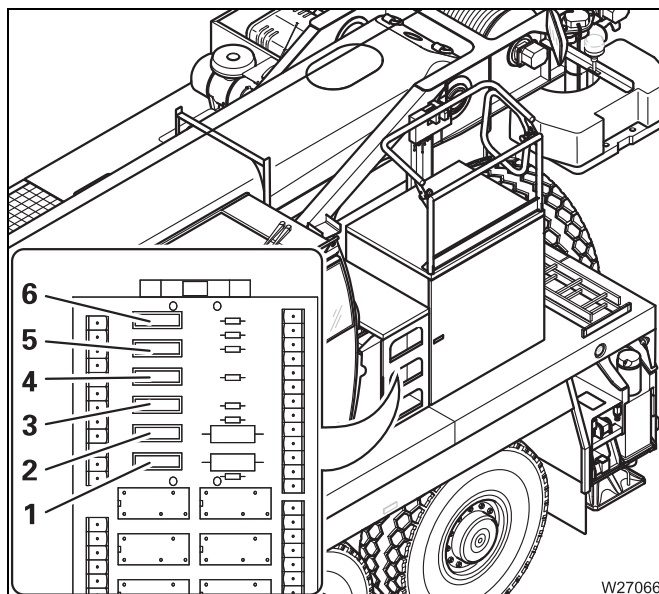

The fuses on the circuit board protect the ECOS control units on the superstructure.





Fuse arrangement:

Item	Designation	Amperage (A)
1	ESX 1 D+	3
2	ESX 1 UE	3
3	ESX 1 8.5 V	2
4	ESX 0 D+	3
5	ESX 0 UE	3
6	ESX 0 8.5 V	2

14.4.4 Malfunctions in the hoist cameras

Malfunction	Cause	Solution
No image appears on the monitor after it is switched on.	Fuse F5/5 blown	Replace blown fuse;  p. 14 - 5.
	Fuse blown – in camera or monitor.	Check fuses and replace as necessary;  <i>Manufacturer operating instructions.</i>
	Connection between camera and monitor is disconnected.	Check cable connection and notify CraneCARE if necessary.

14.4.5 Malfunctions in the main boom camera

Malfunction	Cause	Solution
No image appears on the monitor after it is switched on.	Fuse on the crane cab blown	Replace blown fuse;  p. 14 - 5.
	Fuse blown – in camera or monitor.	Check fuses and replace as necessary;  <i>Manufacturer operating instructions.</i>
	Radio connection between camera and receiver is interrupted.	Adjust the receiver on the crane cab.
	Connection between receiver and monitor is disconnected.	Check cable connection and notify CraneCARE if necessary.

14.4.15 Troubleshooting the RCL

This section contains general malfunctions which are not displayed on the *RCL* control unit as well as malfunctions which prompt an error display on the *RCL* control unit.



Risk of accident

Immediately stop operating the crane if an error message is displayed. The RCL may only be repaired by trained and qualified personnel.



Risk of accident by faulty or overridden RCL

In the event of a faulty RCL, first try to correct the error with the information in this section. Only override the RCL if it becomes absolutely necessary in order to lower the load in the event of an emergency.

Do not carry out any movements which increase the load moment in the event of a faulty or overridden RCL.

If the RCL is overridden, the crane operations are not monitored and no shutdown procedures are initiated when leaving the working range.

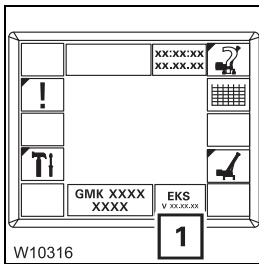

RCL programme version

Always note down the number of the program version after a malfunction occurs and before notifying **Manitowoc Crane Care**.

- Open the main menu, if necessary.

The display (1) indicates the programme version.

General malfunctions

Malfunction	Cause	Solution
RCL not working – dark displays, no buzzer tone	Power supply not switched on	Switching on the ignition
	Fuse F3/3 blown	Replace blown fuse; ➡ p. 14 - 6.
	Fuse RCL F6 blown	Replace blown fuse; ➡ p. 14 - 11.



Error messages

If ECOS detects an error, an error message is shown:

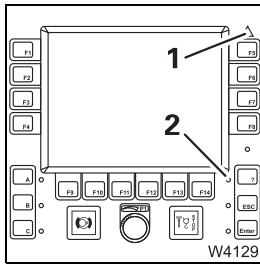

- lamp (1) flashes and
- lamp (2) flashes.

Open the *Errors* submenu for more information.

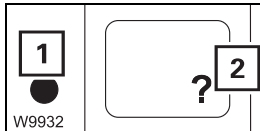

- Press the button (2) once. The button is only active when the lamp (1) flashes or lights up.

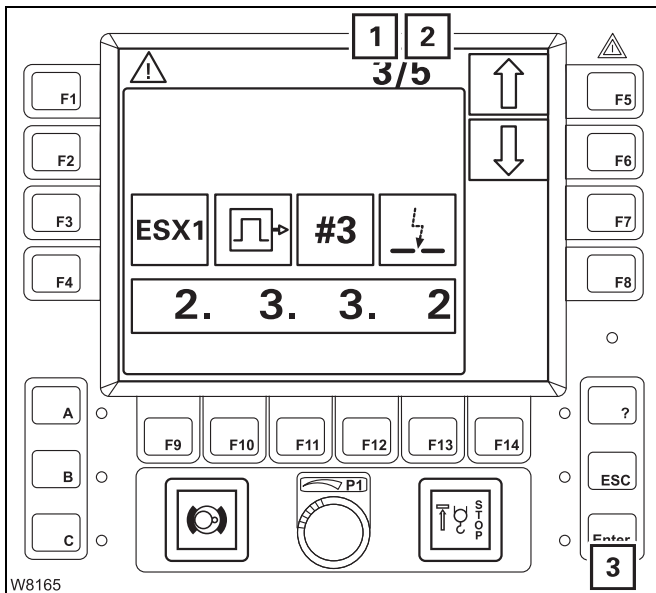

This opens the *Errors* submenu.

Display (2) shows the error total, and display (1) shows which error is displayed.

3/5, for example, means:

- Error **3** is shown
- There is a total of **5** errors.

If the error shown is not acknowledged, the lamp next to the button (3) lights up.

To acknowledge the error

- Press the button (3) once.

If there are further errors, the next error is displayed and can be acknowledged.

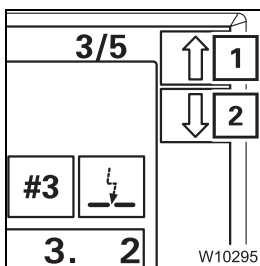

- When all errors have been acknowledged, you can retrieve any pending errors using the buttons next to the symbols (1) and (2).

- 1 Next error
- 2 Previous error

Every time you press the button, the next error will be displayed.

When you keep the button pressed, all errors are shown one after the other continuously.



If not all errors have been acknowledged, the buttons (1) and (2) have no function – the symbols are grey.



14.5.2

Telescoping emergency programme

In the event of a malfunction in the telescoping mechanism, you can retract the main boom with the *Telescoping* emergency programme.

The emergency programme is not intended for crane operation and is therefore restricted to a certain amount of time.

Start the emergency program



Only start the emergency program when the symbol (1) is displayed;
Telescoping mechanism error messages, p. 14 - 21.

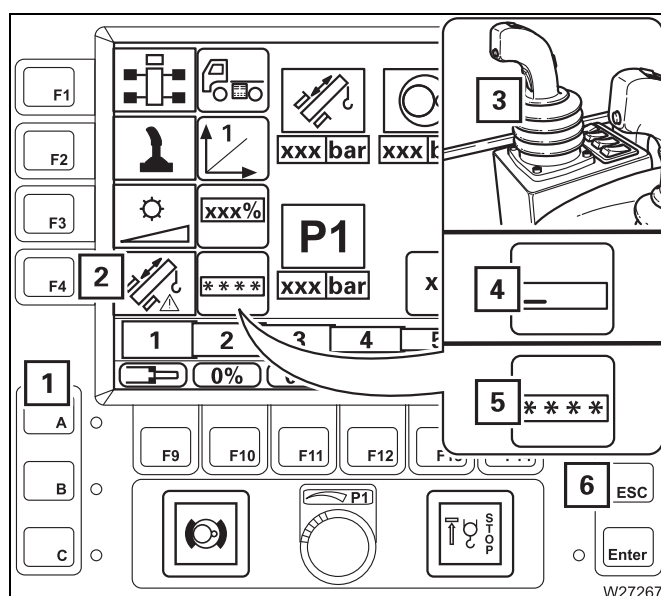

- Press the right dead man's switch (3).
- Also press button (2) once – symbol (4) appears.
- Press the buttons (1) in the following order:



The symbols (5) confirm the entry.

If your input was incorrect, all symbols (5) go out and you need to re-enter.

You can cancel the entry at any time using button (6).

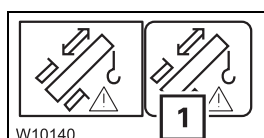

When input is correct, the symbol (1) is displayed – the *Telescoping* emergency programme starts.

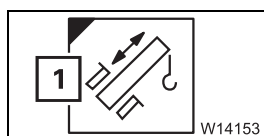

- In the main menu press button (1) once.
The *Telescoping* submenu opens.



14.5.3

Entering the current telescoping

ECOS no longer displays the current telescoping:

- if you telescoped in emergency mode, or
- if the power supply was interrupted in the course of saving data.

In these cases, you must enter the current telescoping, e.g. the values from the RCL display.



- In the main menu press button (1) once.
This opens the *Settings* submenu.

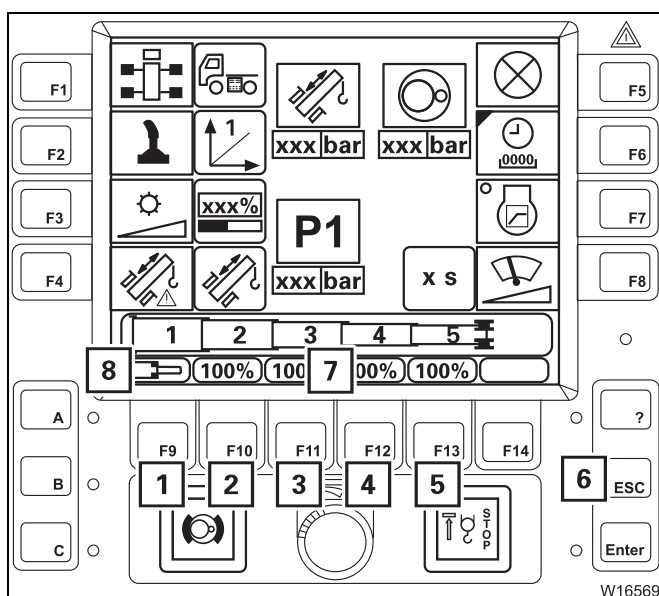

Entering the current telescoping

The display (7) shows the values for telescopic sections I to V.

- Press one of the buttons (1) to (5) – the values in the display (7) turn yellow.

After each press, the associated value in the display (7) alternates unendlessly between the fixed lengths and the symbol (8) for *Unlocked*.

- Enter the desired set values for all the telescopic sections, e.g. unlocked, 100%, 100%, 100%, 100%.

You can cancel the entry at any time using the (6) buttons.



14.6.2

Connecting/disconnecting hoses

- Turn off the engines for driving and crane operations.

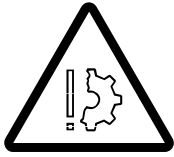

Risk of damage to the hoses

Lay the hoses in such a manner that they can be moved freely in order to prevent them from being crushed or torn or getting caught during the subsequent crane movements.

Establishing connections

The hoses are assigned according to the various diameters.

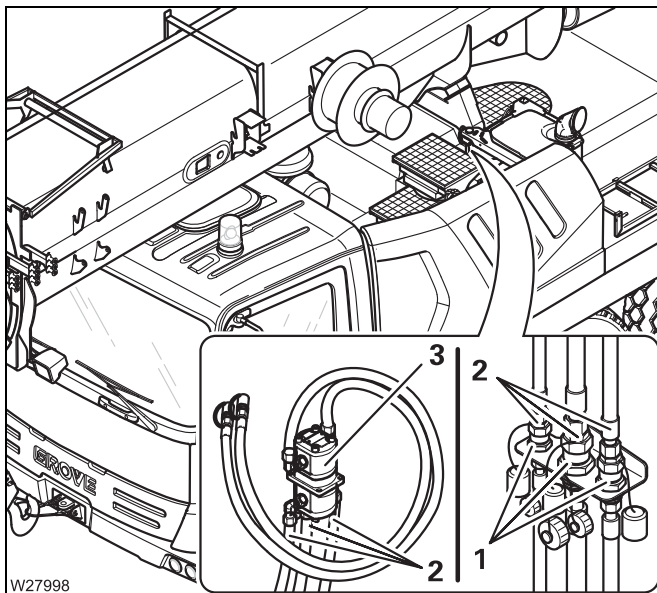

On the carrier

- Attach the transformer (3) to the superstructure.
- Connect the hoses (2) to the connections (1).

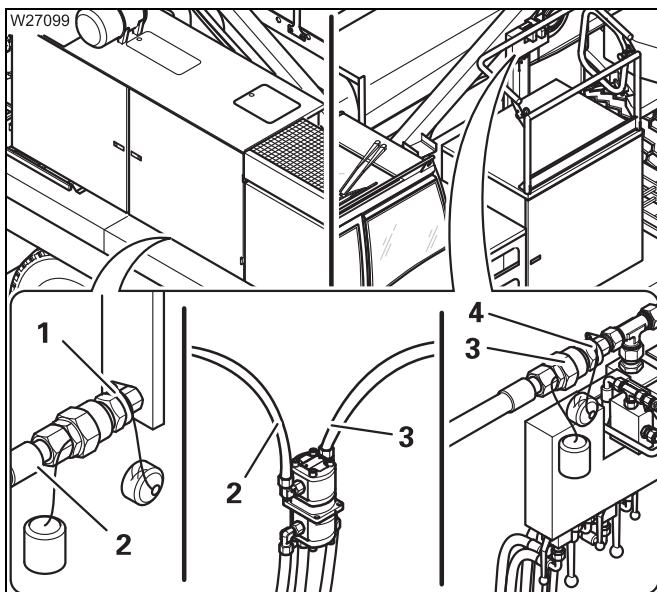

On the superstructure

- Connect the thicker hose (2) to the connection (1).
- Connect the thinner hose (3) to the connection (4).



14.6.7

Emergency supply of another crane

For emergency supply

The hoses are assigned according to the various diameters.

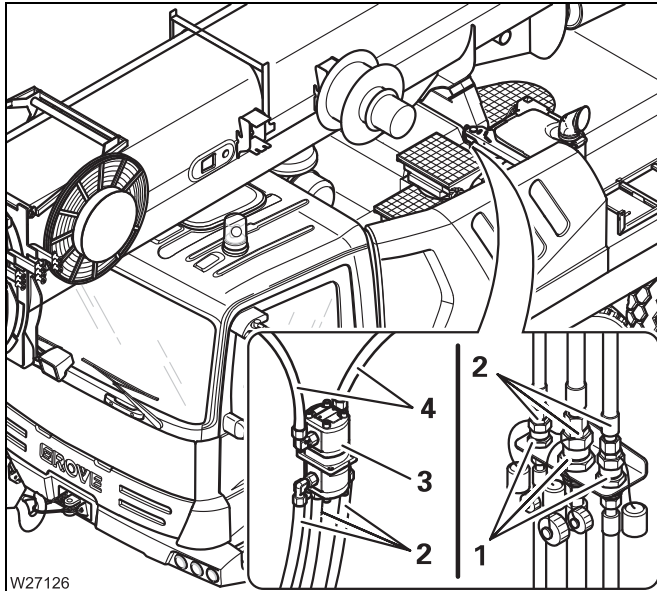

On the crane to be supplied

- Attach the transformer (3).
- Connect the hoses (4); *Operating manual of the other crane.*

On the GMK 4100

- Turn off the engine for driving.
- Connect the hoses (2) to the connections (1).
- Switch on the hydraulic emergency operation; p. 14 - 69.

After emergency supply

- Switch off the hydraulic emergency operation; p. 14 - 69.

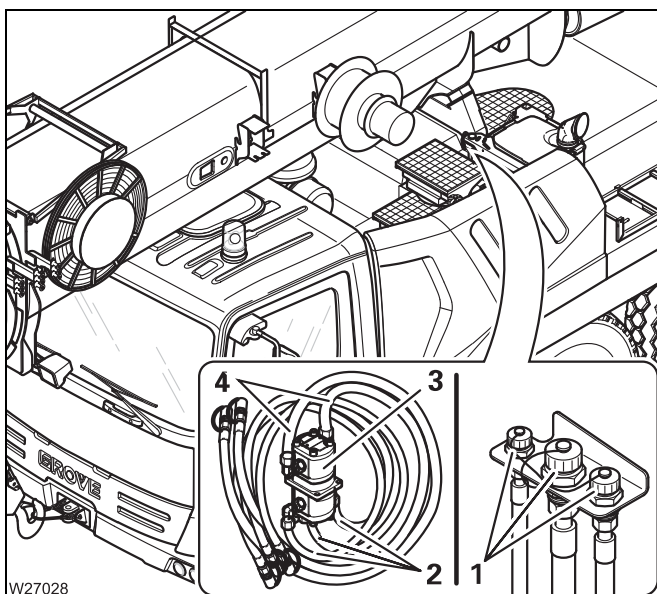

On the GMK 4100

- Remove the hoses (2) from the connections (1).

On the crane that was supplied

- Disconnect the hoses (4).
- Close all the hoses and connections with the caps.
- Remove the transformer (3).

Door	9 - 121
Inclining	11 - 103
Operating elements	
Auxiliary air heater	9 - 17
Auxiliary water heater	9 - 16
Console, rear	9 - 14
Control lever configuration	9 - 20
On the control panels	9 - 18
On the ECOS control unit	9 - 22
On the ECOS display	
Main menu	9 - 24
Submenus	9 - 26
On the front panel	9 - 10
On the hand-held control	9 - 53
On the outrigger control units	9 - 56
On the RCL control unit	9 - 42
On the RCL display	
Main menu	9 - 44
Submenus	9 - 45
On the side panel	9 - 11
Standard heating system	9 - 15
Overview	9 - 8
Rear window	9 - 121
Standard heating system	11 - 133
Ventilating	11 - 134
Windscreen	9 - 120
Crane operation	
At low temperatures – CHECKLIST	10 - 4
CHECKLIST – checks before operating the crane	11 - 1
Permissible slewing ranges	11 - 51
Preheating the hydraulic oil	11 - 13
Rigging – CHECKLIST	12 - 1
Unrigging – CHECKLIST	12 - 7
What to do in the event of malfunctions	14 - 3
D DEF system	
Malfunctions in the DEF system	7 - 25, 14 - 15
Notes on torque reduction	5 - 53, 11 - 114
Operating elements in the crane cab	9 - 63
Operating elements in the driver's cab	3 - 40
Refuel	4 - 8, 10 - 7
Derricking gear	11 - 63
Raising and lowering	11 - 64
Short description of the operating elements	9 - 89
Switching off	11 - 65, 11 - 66
Switching on	11 - 64
Diagnostics plug	9 - 120
Differential locks	
see Longitudinal differential locks	
see Transverse differential locks	

CLICK HERE TO **DOWNLOAD** THE COMPLETE MANUAL

- Thank you very much for reading the preview of the manual.
- You can download the complete manual from: www.heydownloads.com by clicking the link below



- Please note: If there is no response to CLICKING the link, please download this PDF first and then click on it.

CLICK HERE TO **DOWNLOAD** THE COMPLETE MANUAL