

Operating Instructions

CE

Hydraulic Excavator

RH 170 No.

Bucyrus HEX GmbH



CLICK HERE TO **DOWNLOAD** THE COMPLETE MANUAL

- Thank you very much for reading the preview of the manual.
- You can download the complete manual from: www.heydownloads.com by clicking the link below



- Please note: If there is no response to CLICKING the link, please download this PDF first and then click on it.

CLICK HERE TO **DOWNLOAD** THE COMPLETE MANUAL



1 INTRODUCTION

	Operating instructions	Target group
Part 1	INTRODUCTION FUNDAMENTAL SAFETY INSTRUCTIONS	Operating personnel + Inspection and servicing personnel + Repair personnel
Part 2	OPERATION	Operating personnel The operating personnel must have know-how relevant to the operation and the application of this or comparable machines.
Part 3	INSPECTION AND SERVICING	Inspection and servicing personnel The inspection and servicing personnel must have know-how relevant to the inspection and servicing of this or comparable machines.
Part 4	REPAIR WORK	Repair personnel The repair personnel must have know-how and experience relevant to the repair of this or comparable machines.
Part 5	ANNEX	Operating personnel + Inspection and servicing personnel + Repair personnel
Part 6	INDEX	Operating personnel + Inspection and servicing personnel + Repair personnel

Warning of special dangers

Electric energy

Use only original fuses with the specified current rating. Switch off the machine immediately if trouble occurs in the electrical system.

When working with the machine, maintain a safe distance from overhead electric lines. If work is to be carried out close to overhead lines, the working equipment must be kept well away from them. Caution, danger! Check out the prescribed safety distances.

If your machine comes into contact with a live wire

- ➔ do not leave the machine
- ➔ drive the machine out of the hazard zone; warn others against approaching and touching the machine
- ➔ have the live wire de-energized
- ➔ do not leave the machine until the damaged or contacted line has been safely de-energized.

The electrical equipment of machines is to be inspected and checked at regular intervals. Defects such as loose connections or scorched cables must be rectified immediately.

High-voltage system

Floodlamps equipped with gas discharge lamps require a high-voltage supply (ca. 25 kV).

The high voltage is generated by a ballast unit. Switch off the electrical system of the excavator before touching the lamp or the ballast unit.

Battery

Warning! Battery Posts, terminals and related accessories contain lead and lead compounds, chemicals known to cause cancer and reproductive harm. Wash hands after handling

Gas, dust, steam and smoke

Always start and operate the engine in a well-vented area;

If in an enclosed area, vent the exhaust to the outside;

Do not modify or tamper with the exhaust system

Diesel engine exhaust and some of its constituents are known to cause cancer, birth defects, and other reproductive harm

Operate fuel-operated heating systems only on adequately ventilated premises. Before starting the machine on enclosed premises, make sure that there is sufficient ventilation.

Observe the regulations in force at the respective site.

Carry out welding, flame-cutting and grinding work on the machine only if this has been expressly authorized, as there may be a risk of explosion and fire.

Before carrying out welding, flame-cutting and grinding operations, clean the machine and its surroundings from dust and other inflammable substances and make sure that the premises are adequately ventilated (risk of explosion).

CALIFORNIA Proposition 65 Warning

Diesel fuel and Diesel engine exhaust and some of its constituents are known to the State of California to cause cancer, birth defects, and other reproductive harm.

Hydraulic equipment

Check all lines, hoses and screwed connections regularly for leaks and obvious damage. Repair damage immediately. Splashed oil may cause injury and fire.

Depressurize all system sections and pressure pipes (hydraulic system) to be removed in accordance with the specific instructions for the unit concerned before carrying out any repair work.

Hydraulic lines must be laid and fitted properly. Ensure that no connections are interchanged. The fittings, lengths and quality of the hoses must comply with the technical requirements.

OPERATION, FIRE AND EXPLOSION HAZARD



Safety instructions

Prior to commencing work, obtain information on the national and corporate rules for the prevention of accidents and avoiding fires.

Pay particular attention to hazards caused by combustible and easily flammable substances.

Obtain information on the safe handling of the fire extinguishers to be used.

Avoid smoking and open fire on, next to and below the excavator.

Combustible and easily or highly inflammable substances or liquids increase the risk of fire and explosion

Do not store or transport flammable substances on the excavator during the work. This is also valid for pressure vessels containing flammable substances as, for instance, spray oil or cold-starting fluid (ether). They are heat-sensitive and can explode even if exposed only to intensive sunlight.

Clean the excavator carefully, if oil, grease, fuel, detergents or cold-starting fluid have been spilt over the machine. If possible, use a steam-jet cleaner for cleaning.

These substance can also ignite themselves if they come close to hot units or objects as, for instance, a turbocharger.

Clean rubber or electrical with compressed air only.

Ensure sufficient ventilation.

Even battery gases can ignite in open flames or fire.

Avoid parking the excavator in places where

- combustible substances such as coal dust or tar are present.
- open or smouldering fire may occur.

Remove the excavator from such an area where combustible or easily flammable liquids have spilled from the excavator onto the ground.

Flying sparks (caused by welding, flame cutting, grinding, electrical short-circuit) may cause fire on the ground that can spread to the excavator.

Clean the excavator before starting work.

Place suitable fire guardings (fire barriers) if open fire or flying sparks cannot be avoided during repair work.

If necessary, also cover the ground with fire-protective blankets.

Apply special protection to cables, cable ducts as well as to hose and pipe lines.

The engine compartment can be equipped with pressure vessels containing cold-starting fluid (ether). Ether is toxic and highly flammable; the vessels are under pressure. These pressure vessels can explode if exposed to high temperatures (above 49°C / 120°F) or in the event of damage. Protect the pressure vessels against damage before beginning to work in or close to the engine compartment.

Ensure sufficient ventilation.

Do not keep any fire extinguishers that are not suitable or have not been tested.

Do not extinguish flammable liquids with water. Use:

- dry-powder, carbon-dioxide or foam extinguishing compounds.

When getting into contact with burning substances, the fire-fighting water would abruptly evaporate and distribute the substance such as oil over a wide area. Water causes short-circuits in the electrical system thus possibly entailing new hazards.

Call the fire brigade.

Have all your welding, flame cutting and grinding work approved before starting work.

Cab interior lamp

The interior lamp is switched on and off with switch (Fig. 2-17:).

Switch position 0 - lamp off,
1 - lamp on.

The interior lamp is also switched on and off with switches (arrow, Fig. 2-18:) and / or (96, Fig. 2-19:).

The interior lamp can be used even if the electrical system is switched off.

Therefore, switch off the interior lamp when leaving the machine. The batteries may be discharged if the interior lamp is left on for prolonged periods.

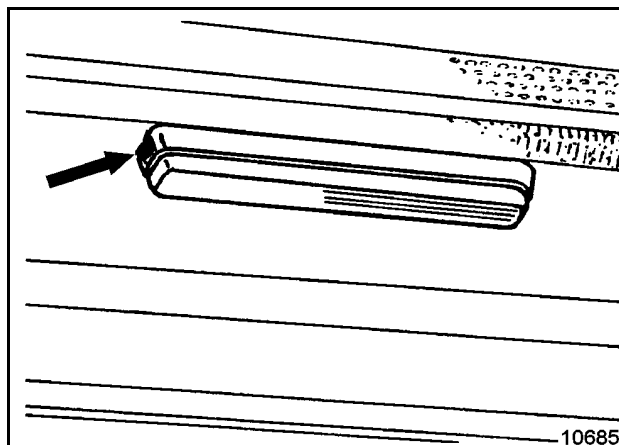

Fig. 2-17:

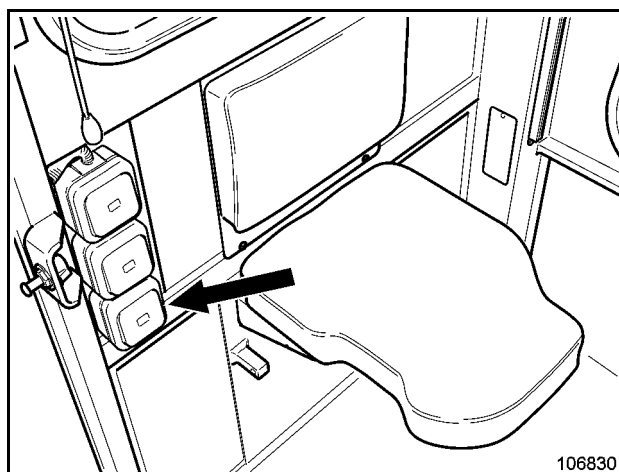

Fig. 2-18:

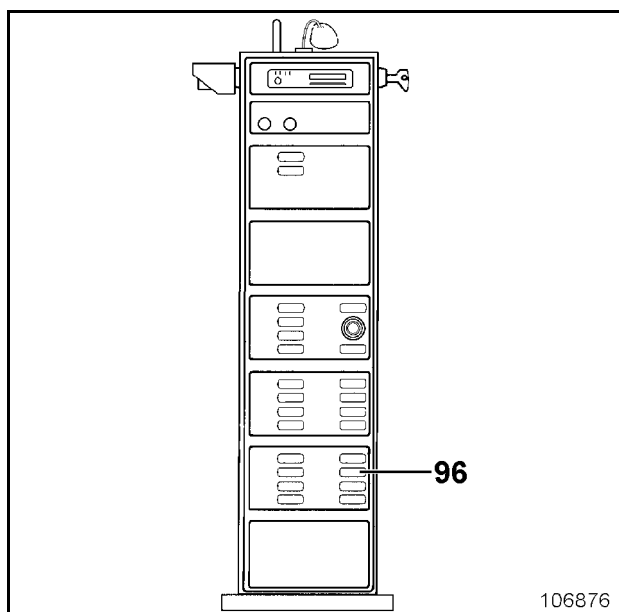

Fig. 2-19:

- Hang up loop (4, Fig. Fig. 2-42:) into snap hook (16).

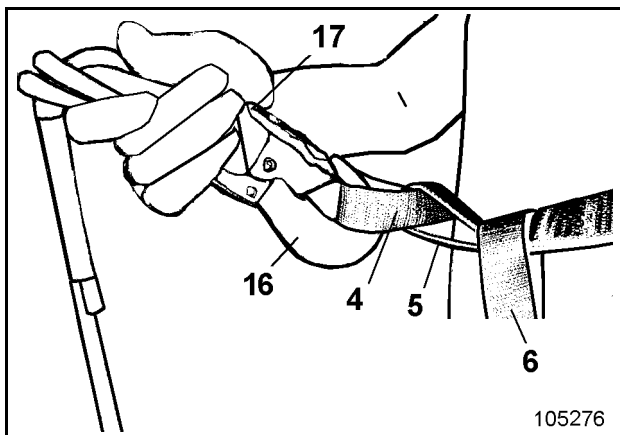

Fig. 2-42:

- Release hooking safety device (17, Fig. 2-43:).

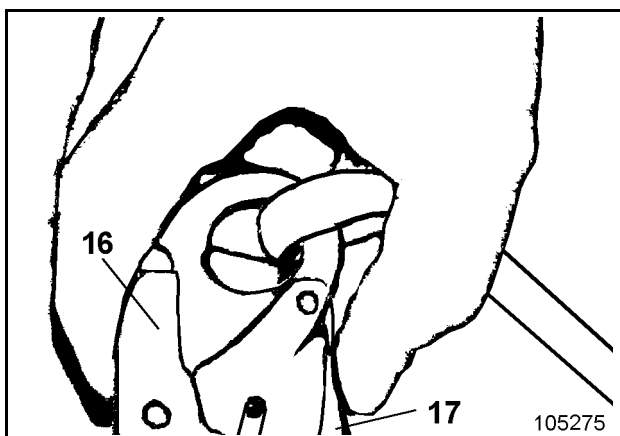

Fig. 2-43:

If you have the harness put on in such a way in case of danger you can escape from the excavator (Fig. 2-44:).

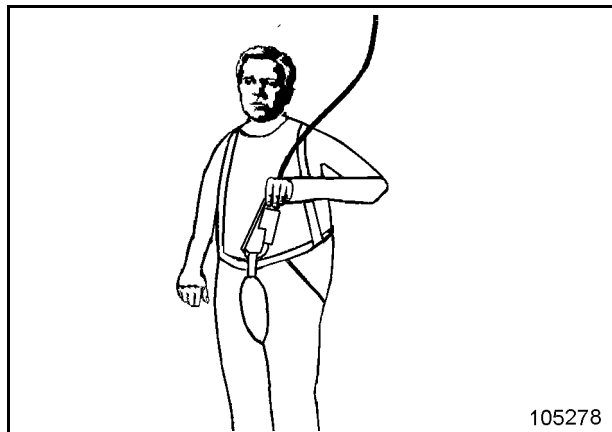

Fig. 2-44:

Fig. 2-49:







No.	Element	Function	Symbol
51	Switch Starting (left engine 1)	Starts the engine: Hold switch approx. 5 – 7 sec. This is necessary to start and pressurize the engines prelube system. After then the engine starts automatically.	
52	Switch Stopping (left engine 1)	Shuts off the engine.	
53	Switch Idling (left engine 1)	Shuts off the engine with 5 minutes after run.	
54	Switch	Not connected.	
55	Momentary switch Diagnostic ON / OFF	With the engine at standstill push momentary switch to the left and hold: Stored faults in the left engines electronic unit can be displayed. Faults are displayed by warning lamp no. 43 as flashing sequences (see: "Engine electronic unit, displaying stored fault codes").	
56	Speed adjustment Potentiometer (left engine 1)	Changes engine speed: <ul style="list-style-type: none"> ▪ turn CCW to limit stop - idling speed ▪ turn CW to limit stop - full-load speed 	
57	Momentary switch Diagnostic increment / decrement	Not connected.	

Fig. 2-54:

No.	Element	Function	Symbol
101	Button Counting dumpers	Reset with switch (92).	
102	Button Stick floating position (only for loading shovel equipment)	If actuated: Stick cylinders are pressurized when retracted.  Actuate button (102) only when control lever (115) is in "0" position.	
103	Button Boom floating position	If actuated: Boom cylinders are pressurized when retracted.  Actuate button (103) only when control lever (116) is in "0" position.	
104	Button Warning signal	Activates the horn.	
105	Button Electronic excavator control	Switches the electronic excavator control on and off.	
111	Pedal Bottom-dump bucket (only for loading shovel equipment)	Opens / closes the bottom-dump bucket.	
112	Pedal Travelling, left track	Forwards / reverse	
113	Pedal Travelling, right track	Forwards / reverse	
115	Control lever	Lifts and lowers the bucket / backhoe bucket stick; Swings and brakes the superstructure.	
116	Control lever	Raises and lowers the boom; Tipping and rearward tilting of bucket resp. backhoe bucket.	
117	Button Bottom-dump bucket (only for loading shovel equipment)	To the left – opens the bottom-dump bucket. To the right – closes the bottom-dump bucket.	
118	Button By-pass for the automatically switched off for stick- and/or backhoe cylinders (Option)	To the left – automatically stopped stick- and/or backhoe cylinders can be driven slowly to the limit stops. To the right – Not connected.	

(Fig. 2-59:)

(Options. Depending on the options ordered with the machine, the described elements can be found on different positions on the control column).

Pos.	Benennung	Funktion	Symbol
211	Warning lamp Oil interval prolonging (left engine 1)	Lamp is lit up, when one oil pump is running flashes or pulsates, when both oil pump are running	
212	Warning lamp Oil burning left engine 1)	Lamp lits up green, when the oil burning system is ready to operate. Additional a fault code is indicated.	
213	Warning lamp Oil burning left engine 1)	Lamp lits up red, when a fault occurs in the oil burning system. Additional a fault code is indicated.	
214	Warning lamp Oil interval prolonging (right engine 2)	lamp is lit up, when one oil pump is running flashes or pulsates, when both oil pump are running	
215	Warning lamp Oil burning right engine 2)	Lamp lits up green, when the oil burning system is ready to operate. Additional a fault code is indicated.	
216	Warning lamp Oil burning right engine 2)	Lamp lits up red, when a fault occurs in the oil burning system. Additional a fault code is indicated.	

Shutting off the engines

During interruptions of the work and after the work, stand working equipment on the ground.

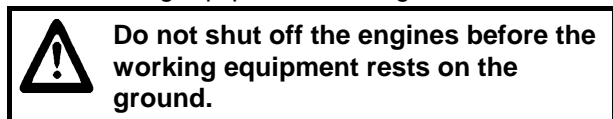

- Turn speed control knob (56 and 66, Fig. 2-80:) counter-clockwise to the limit stop (idling speed).

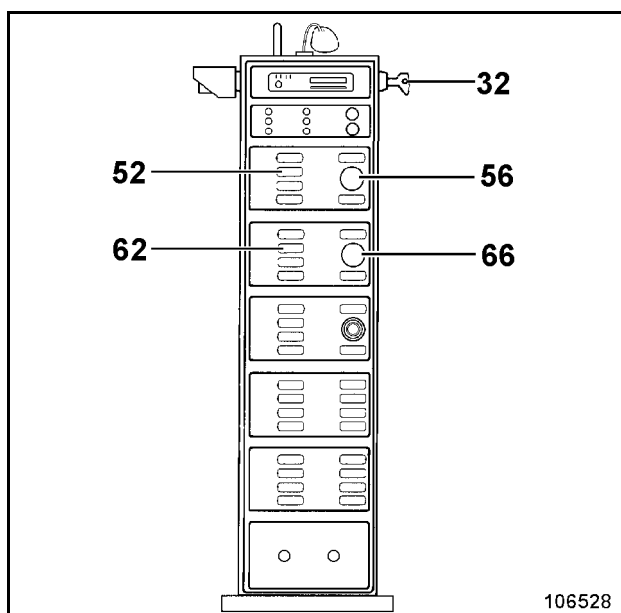
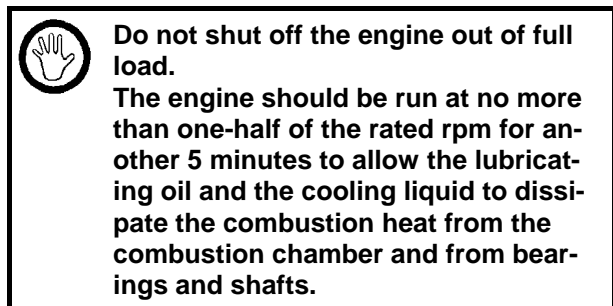

Fig. 2-80:



- Depress key (52) for the lefthand engine.
- Depress key (62) for the righthand engine.
- Turn key in key-switch (32) counter-clockwise and withdraw (electrical system without current).

Emergency - stop

In case of emergency, e.g. if buzzer (33, Fig. 2-81:) sounds, the engine can be shut off from full load.

To do so:

- Depress stop-switch (31) (the whole electrical system is switched off).
The engines are shut off.
- Turn key in key-switch (32) counter-clockwise and withdraw.

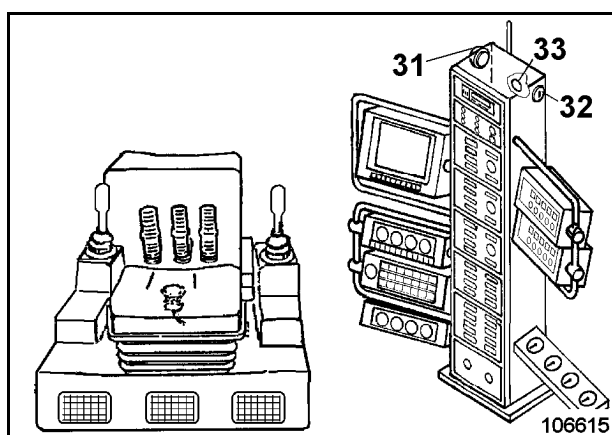

Fig. 2-81:

Positioning of the machines

The auxiliary machine is driven close to the RH170B from behind (Fig. 2-100:).

Loosen the high-pressure lines (1, 2, 3 and 4, Fig. 2-101) and close the open ends of the hoses.

- Connect the hoses from the auxiliary machine to the ports of the "travel hydraulics" of the excavator.
- High-pressure hoses (1 and 2) - circuit 1 on auxiliary machine
- High-pressure hoses (3 and 4) - circuit 2 on auxiliary machine



Do not allow pressure in control line to rise above 30 bars / 435psi as this will shift the track gears into their "fast" ranges.

Emergency travel

- Start up the engine of the auxiliary machine. The brakes of the RH170B are released by travel pressure.
- Initiate the travelling movements carefully with the control levers. Adjust the direction and travelling speed of both tracks accordingly.
- Shift the control lever to the final position. Make sure the auxiliary machine is able to "follow"

The RH170B can be steered as usual by releasing the one or the other control lever briefly.



Drive the excavator out of the hazard zone only.

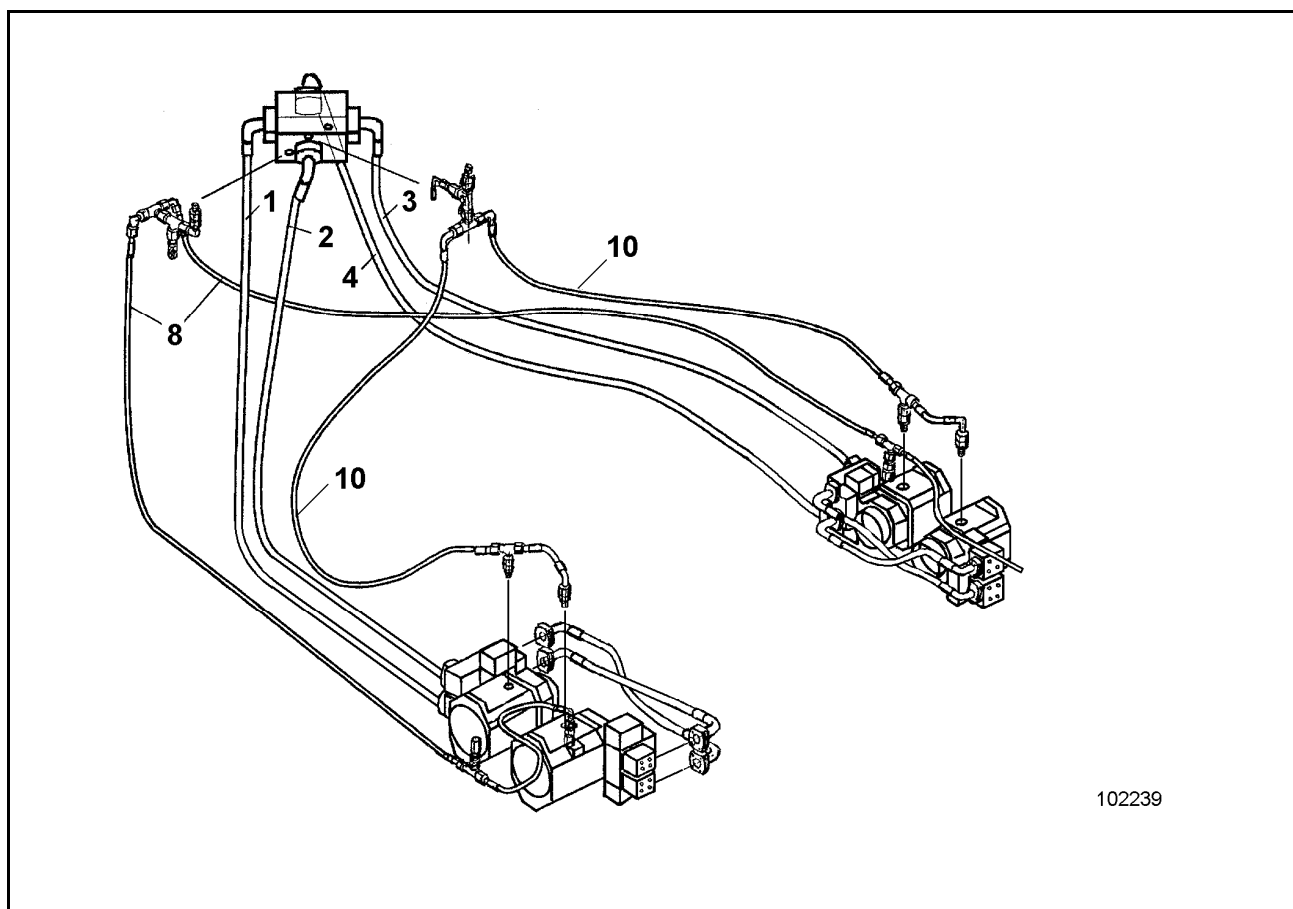

102239

Fig. 2-101

Securing the machine

Risk of injury

The machine must not be started by unauthorized persons.

Therefore, secure the machine.

Observe the accident prevention regulations.

Depressurize pipeline systems, on which work is to be carried out, by appropriate measures.

Protective shrouds of moving machine parts may only be opened or removed when the drive unit is stationary and protected against inadvertent starting.

Before carrying out fitting works, the machine and the equipment must be protected against inadvertent starting by placing chocks under the tracks and by standing the working equipment on the ground.

Hydraulic and lubricating systems

Close all open bores, pipe and hose connections with pressure-resistant plugs.

Refill collected hydraulic oil back into the hydraulic system only through the return-flow filters. Dispose of non re-usable oils without polluting the environment.

All components of Bucyrus HEX machines have been carefully purpose-coordinated. Trouble-free operation and a long service life can only be achieved with original Bucyrus HEX spare parts.

Respect the sequence of working operations when fitting or replacing the attachments. The sequence has been determined and tested by qualified experts.

Secure the machine as described below:

- before carrying out any fitting and modification work on the working equipment,
- before carrying out any servicing and repair work on the machine.
- Park the machine on level and stable ground.
- Stand the working equipment on the ground.
- Shut off the engines.
- Depressurize the hydraulic system.
- Withdraw the key from the key-switch.

Handling batteries

Battery Posts, terminals and related accessories contain lead and lead compounds, chemicals known to cause cancer and reproductive harm. Wash hands after handling.

Batteries give off explosive gases.

Never handle batteries close to naked flames and unshielded light sources, never smoke.

Battery acid is toxic and corrosive.

Avoid any contact with the skin, mouth, eyes and clothing. Avoid spilling battery acid or inhaling the vapours.

Wear gloves, firm protective clothing and goggles when handling batteries.

If the skin is splashed with acid, rinse thoroughly with running water and consult a doctor.

If the eyes are splashed with acid, rinse thoroughly with running water and consult a doctor immediately.

Never set tools down on the battery. They may induce a short circuit, causing irreparable damage to the battery and injuring persons.

Never wear metal necklaces, bracelets or watch-straps when working on the battery. The metal parts may induce a short-circuit resulting in burns.

Dispose of used batteries separately from other waste in the interests of environmental protection.

Before working on the electrical system

Before performing work on the electrical system where tools, spare parts, etc. can come into contact with electrical conductors or contacts, the battery must be disconnected.

Disconnect first the negative and then the positive terminal.

After the work:

Reconnect first the positive and then the negative terminal.

Handling of cold-starting fluid (ether)

The engine compartment can be equipped with pressure vessels containing cold-starting fluid (ether).

Ether is toxic and highly flammable; the vessels are under pressure. These pressure vessels can explode if exposed to high temperatures (above 49°C / 120°F) or in the event of damage.

Protect the pressure vessels against damage before beginning to work in or close to the engine compartment.

Read and observe the instructions on the pressure vessels.

For further details please refer to the instructions and safety data-sheets of the manufacturer / supplier of pressure vessels with cold starting fluid (ether).

Provide for sufficient ventilation.

Do not eat, drink or smoke when replacing an empty vessel.

Do not inhale the vapours of escaping cold-starting fluid.

In contact with the skin, ether can cause frostbites and irritations. Avoid skin contact.

Wear suitable protective gloves and goggles.

Even apparently empty pressure vessels can still contain rests of ether and therefore explode if they are damaged or heated up above 49°C. They must therefore be handled in the same way as full pressure vessels.

- Do not keep them on the machine.
- Do not damage or open the vessels.
- Do not expose the vessels to great heat or direct sunlight.
- Do not dispose of in fire.
- Keep the vessels in a place inaccessible to unauthorized persons.
- Dispose of the vessels properly.



Plan T and W

Plan T Every 10 OH or every working shift
 (whichever comes first)

Plan W Every 60 OH or every working shift
 (whichever comes first)

Location	Servicing work	Quantity/ No.	Plan T	Plan W
Engine	Check oil level	2	●	●
Engine oil tank	Check oil level	2	●	●
Cooling system				
Cooling fluid level	Check	2	●	●
Radiator	Check / clean	2	●	●
Fuel system				
Fuel filter	Drain off water	2 x 2	●	●
Water trap (optional)	Drain off water	2 x 1	●	●
Fuel tanks	Drain off water and dirt	2	●	●
Air-intake system	Check BCS – indication	1		●
Intake and clean-air lines	Check for tightness and leaks			●
Electrical system				
Lighting	Check operation		●	●
Switchgear cabinet				
- Breather filter				
- Dust trap	Remove dust	1		●
- EMERGENCY OFF button	Check function	2		●
Monitoring, warning and control elements	Check function of monitoring, warning and control elements		●	●
BCS	Check function		●	●
Hydraulic system	Check function of working and travelling movement		●	●
	Inspect visually for leaks			●
Hydraulic oil reservoir	Check oil level	1	●	●
Oil cooler	Check / clean	2		●
Fan wheel	Check condition	2	●	●
Pump transfer gearbox	Check oil level	2		●
- pre-chambers expansion reservoir	Check oil level	2	●	●
Oil filter (tell-tale)	Check	2 x 1		●
Swing gearbox	Check oil level	3	●	●
Travel gearbox	Check for leaks	2	●	●

CLICK HERE TO **DOWNLOAD** THE COMPLETE MANUAL

- Thank you very much for reading the preview of the manual.
- You can download the complete manual from: www.heydownloads.com by clicking the link below



- Please note: If there is no response to CLICKING the link, please download this PDF first and then click on it.

CLICK HERE TO **DOWNLOAD** THE COMPLETE MANUAL



III.b Oils for swing gearboxes

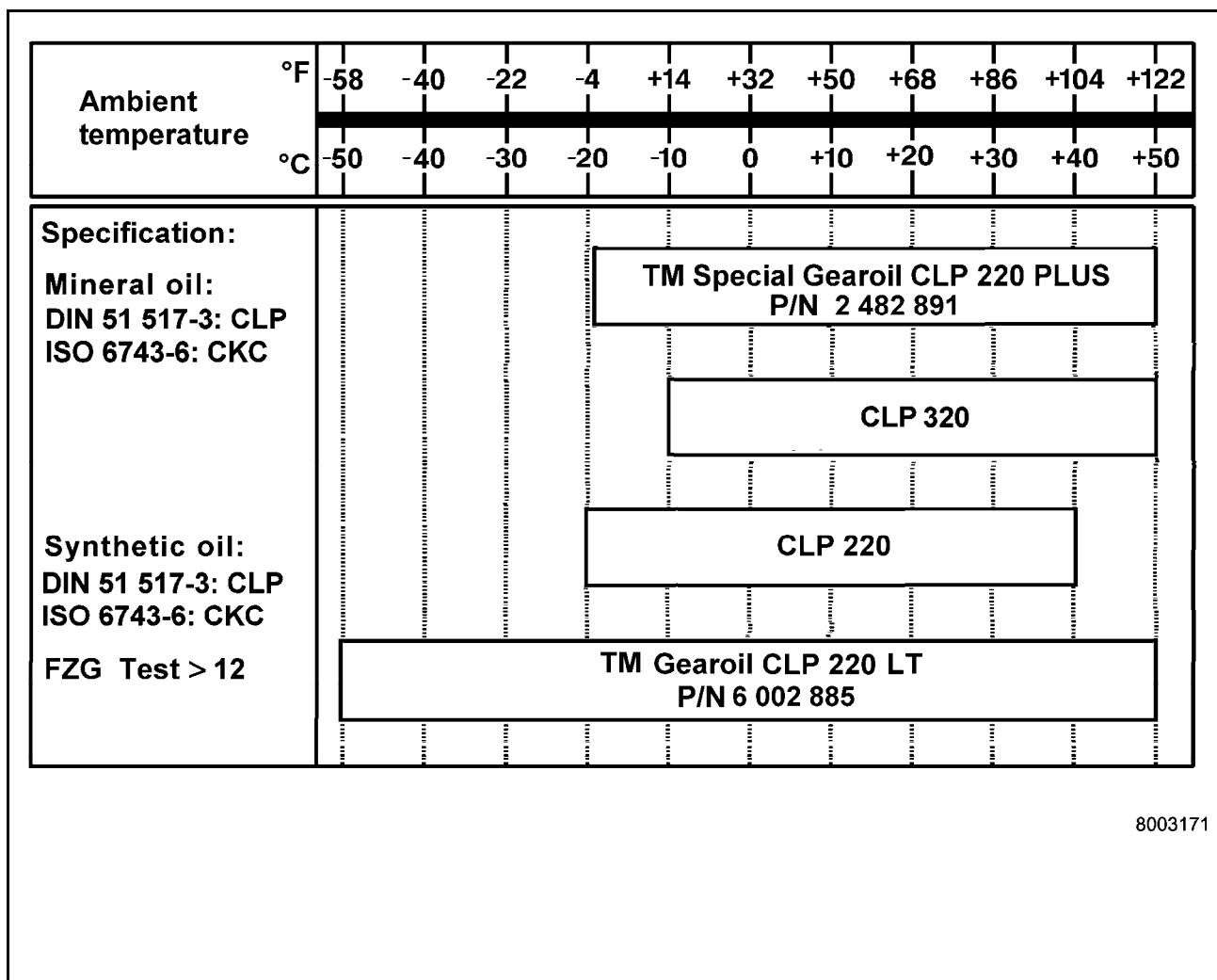

Fig. 3-6:

Filling in engine oil

The engine oil is filled in with the service station (Fig. 3-23:) through

- express coupling (6) for the lefthand engine oil reservoir,
- express coupling (7) for the righthand engine oil reservoir,

until the the inspection glas (1, Fig. 3-24:) is complete filled with oil.

- ➔ Unscrew cap of express coupling and connect hose line of the service vehicle.

The hose line and its use are described in the "Hose line for oil and cooling liquid changes" section.

- ➔ Start the engines and allow to run at idling for abt. 2 minutes.
- ➔ Check oil level and top up with engine oil until the oil level has reached the mark on dipstick (3, Fig. 3-24:).
- ➔ Remove the hose line.
The express coupling closes automatically.
- ➔ Screw on protective cap.

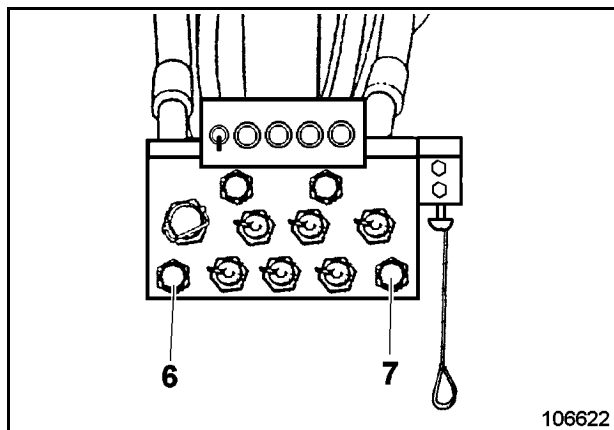

Fig. 3-23:

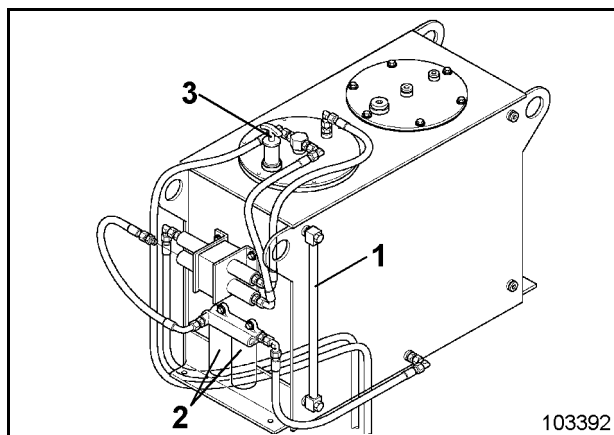

Fig. 3-24:

Topping up cooling liquid

The cooling liquid can also be filled in with the service station (Fig. 3-39:) through

- express coupling (2) for the lefthand engine,
- express coupling (3) for the righthand engine.

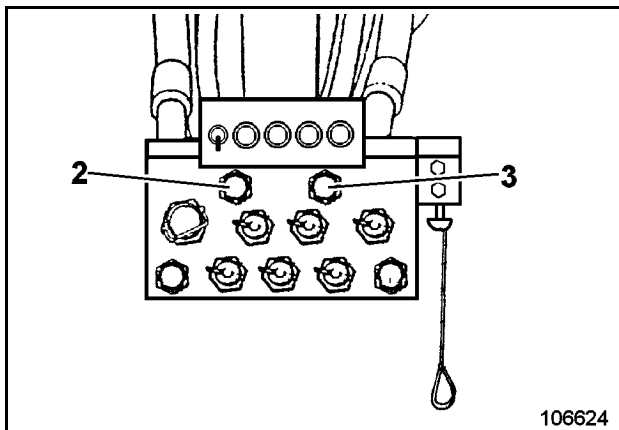

Fig. 3-39:

- Unscrew cap of express coupling. Connect the filling hose of the service vehicle.

The hose line and its use are described in the "Hose line for oil and cooling liquid changes" section.

- Remove hose.
The express coupling closes automatically.
- Screw on protective cap.

Cooling liquid, change



Risk of scalding from hot cooling liquid.

Read and observe: Inspection and servicing – Safety instructions.

The radiators may also be hot. Wear protective gloves and firm working clothing.

Collect escaping cooling liquid and discard without polluting the environment.

The cooling liquid must be changed regularly and after two years at the latest.

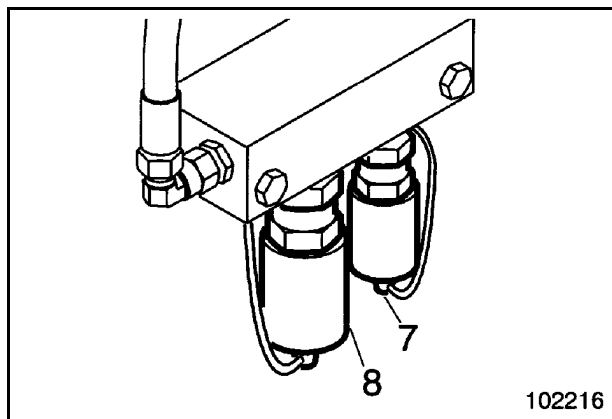

Fig. 3-40:

Draining off cooling liquid

- Shut off the engines.

Drain cooling liquid through express coupling (8, Fig. 3-40:).

- Place a collecting recipient for used cooling liquid under the automatic drain valve.
(The required recipient capacity is set out in the "Filling quantities - Other" table)
- Unscrew cap of express coupling.
- Connect hose.

The hose line and its use are described in the "Hose line for oil and cooling liquid changes" section.

- Remove hose. The express coupling closes automatically.
- Screw on protective cap.

Fuel system, venting

The fuel tanks are vented with breather valves (3, Fig. 3-57:).

Clean breather valves regularly.

- Remove breather valve, flush with paraffin oil and blow clean with compressed air.

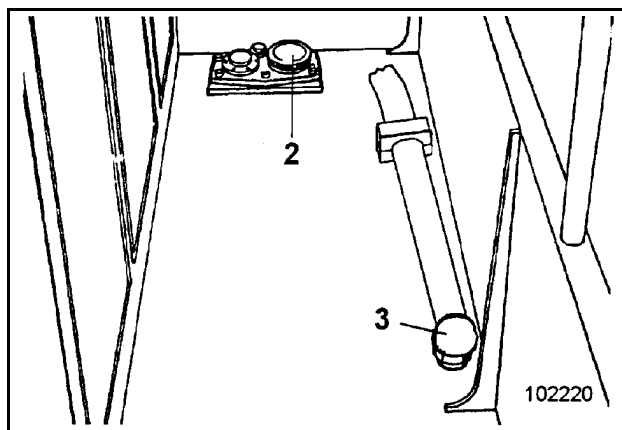

Fig. 3-57:

Cleaning the fuel tanks



Explosion hazard.

**Do not use white spirit, paraffin oil or other solvents.
For flushing and cleaning use diesel fuel.**

Read and observe the "Inspection and servicing, Safety instructions" chapter.

Avoid skin contact. Skin contact with diesel fuel may cause skin injury.

Wear firm working clothing.

Wear protective gloves or use a barrier cream.



Fuel must be prevented from penetrating into the soil. Keep fuel for re-use or discard without polluting the environment.

- Use up as much fuel as possible.
- Check how much fuel remains in the tank and place a collecting recipient of sufficient size under the drain plugs of the tanks.
- Loosen drain plug (5, Fig. 3-58:) at fuel the tank and drain off fuel.
- Flush tank with diesel fuel.
- Screw automatic drain plug backs (5) in place.

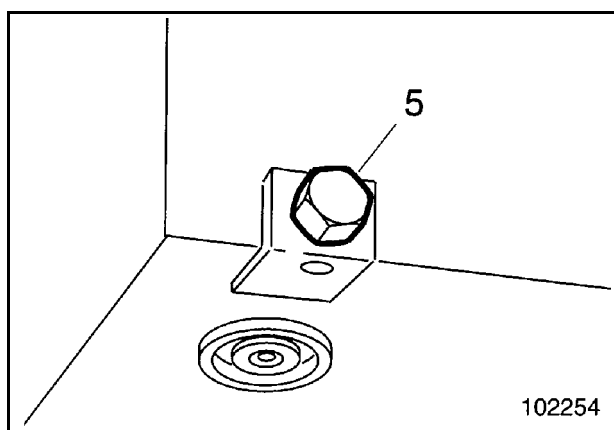

Fig. 3-58:

Replacing a defective Xenon-lamp

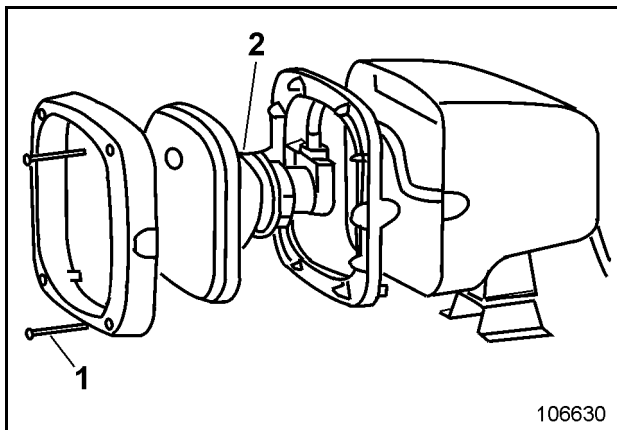

Fig. 3-71

106630

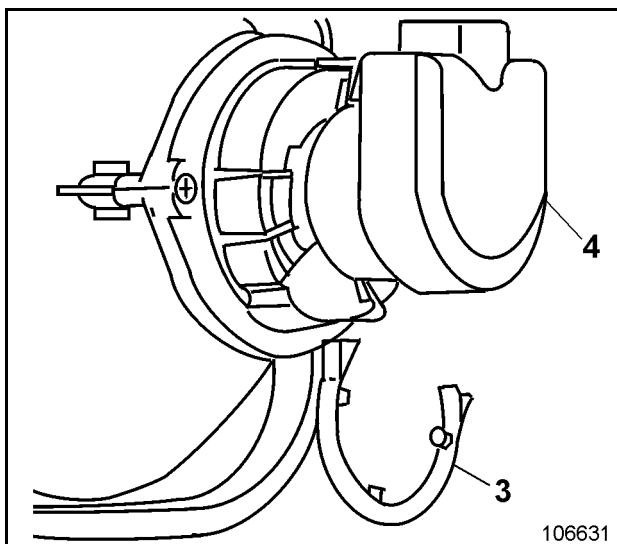

Fig. 3-72

106631

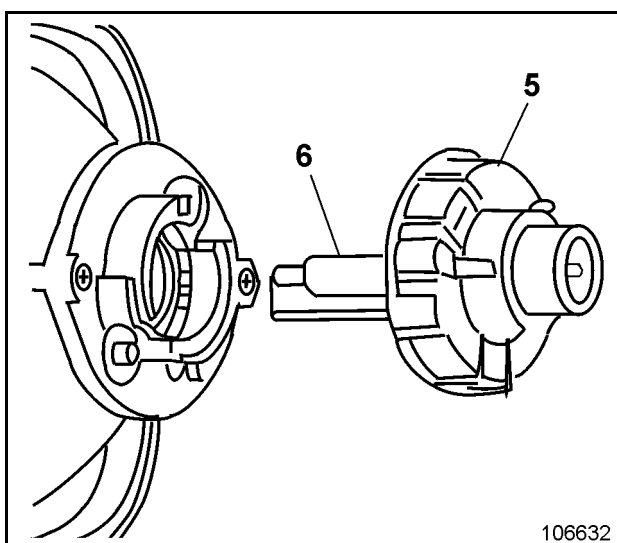

Fig. 3-73

106632



Read and observe the:
„Floodlight projector, replacing the
lamp, Safety instructions“.

- Switch off the projector, shut off the engine and cut out the battery main switch.
- Wait until the housing of the floodlight projector has cooled down.
- Withdraw the power supply connector from the projector.
- Remove four screws (1, Fig. 3-71) and withdraw the reflector (2) from the projector housing.
- Remove the circlip (3, Fig. 3-72). Turn connector (4) counter-clockwise and withdraw.
- Turn lampholder (5, Fig. 3-73) counter-clockwise and pull it out of the reflector together with lamp (6).
- Remove the defective Xenon lamp (6) from the lampholder and replace by a new one. Do not touch the glass bulb of the lamp.
- Reinstall the new lamp and the lampholder.
- Plug the connector into the projector. Refit the circlip.
- Re-assemble the housing.

Filter (control circuit and auxiliary control circuit)

Each of the control circuits is equipped with a high-pressure filter (Fig. 3-92:).



Risk of scalding caused by hot hydraulic oil.

Read and observe the "Inspection and servicing – Safety instructions" chapter.

Shut off the engines.

The hydraulic oil reservoir itself may also be hot. Wear protective gloves and firm working clothing.

Avoid skin contact. Skin contact with hydraulic oil may cause skin injury.

Collect escaping hydraulic oil and discard without polluting the environment.

Replacing the filter element

Change filter element regularly and when the BCS indicates a contamination.

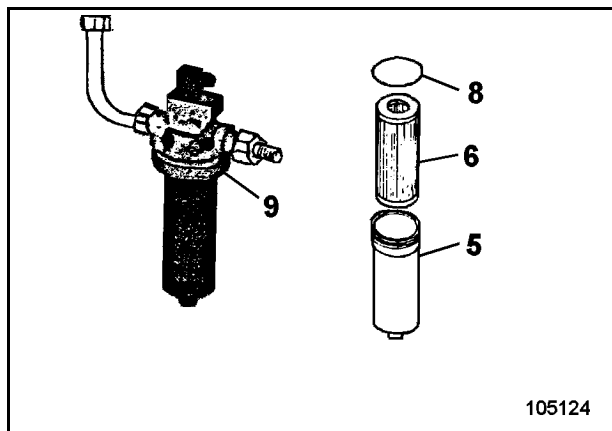

Fig. 3-92:

- Unscrew filter housing (5, Fig. 3-92:).
- Withdraw filter element (6) from filter housing (5).
- Clean filter housing (5) and the sealing face at the filter head (9) with white spirit or paraffin oil.
- Check seals (10 and 14) and replace, if required.
- Insert new filter element into filter housing (5) and refit to the filter head with new, lightly oiled sealing ring (8).
- Check for leaks after putting the filter into operation.

Pressure accumulator - Emergency lowering

To permit the working equipment to be lowered in an emergency, the machine is equipped with a pressure accumulator (1, Fig. 3-112:).

The pressure accumulator (1) is located in the superstructure and is accessible from the ground.

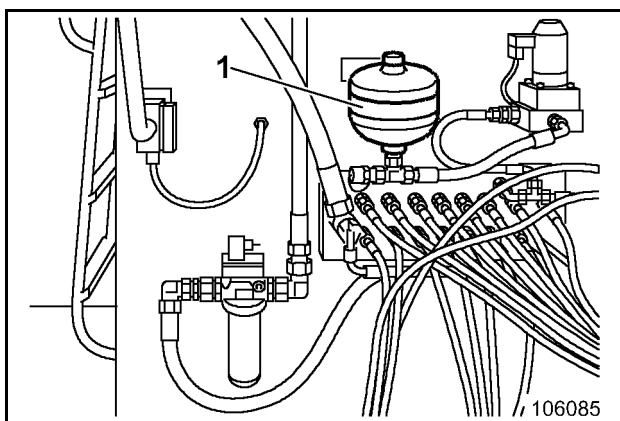

Fig. 3-112:

Pressure-accumulator inspection regulations

The following regulations are applicable only in Germany. Please observe the relevant regulations in force in your own country.

Extract from the German regulations

The accumulator vessel must not be subjected to welding, soldering or any other mechanical work. Work on systems containing accumulators (repairs, connection of pressure gauges or similar work) may be carried out only when the fluid pressure has been released

Extract from the German acceptance regulations

Hydraulic accumulators are pressure vessels and are therefore subject to the "Druckbehälterverordnung (DruckbehV)" [Pressure Vessel Regulations]. Their installation, equipment and operation are governed by the "Technische Regeln Druckbehälter (TRB)" [Technical Rules for Pressure Vessels]. The pressure vessels of hydraulic accumulators are classified by the admissible operating pressure p in bars, the capacity l in liters and the product of pressure and capacity $p \times l$. Depending on the class to which the accumulator belongs, the following inspections are mandatory:

Checking the gas charging pressure in the pressure accumulator

After commissioning (new installation or repair), the gas charging pressure in the pressure vessel must be checked at least once during the first week. If no pressure loss is detected, the second pressure test must be performed after ca. 3 months. If no pressure loss is detected in this test either, the testing interval can be fixed at once pressure test each year.

Group	Inspections prior to commissioning		Regular inspections
	at the factory	at the place of use	
II $p \geq 1$ bar and $p \cdot x \leq 200$	Pressure testing Prototype and pressure test certified by the manufacturer	Inspection certificate (Check of correctness and correct installation) issued by an expert	Inspection schedule to be drawn up by end user, based on experience with type of operation and fluid.

Hydraulic motor chamber, Changing oil

Draining off oil

- Place a collecting recipient for used oil under the hydraulic motor chamber. Choose the required capacity in accordance with the "Refilling quantities - Oil" table.
- Unscrew drain plug (7, Fig. 3-133:) and drain off the oil completely. Slackening plug (5) allows the oil to run out more readily.
- Clean screw plug (7).
- Screw screw plug (7) back in place.

Filling in oil

- Unscrew screw plug (6).
- Fill in oil through opening of plug (5) until it flows out of opening of plug (6).
- Screw plugs (5) and (6) back in place.

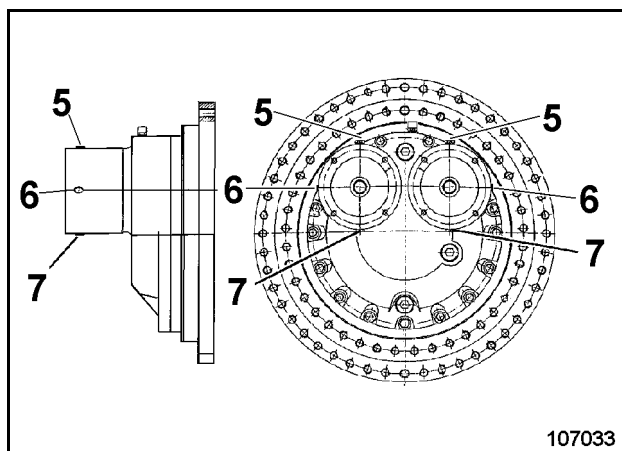

Fig. 3-133:

Breather filter, Clean / Replace

- Unscrew breather filter (1, Fig. 3-134:) and clean in white spirit or parafin. Replace according to maintenance plan.

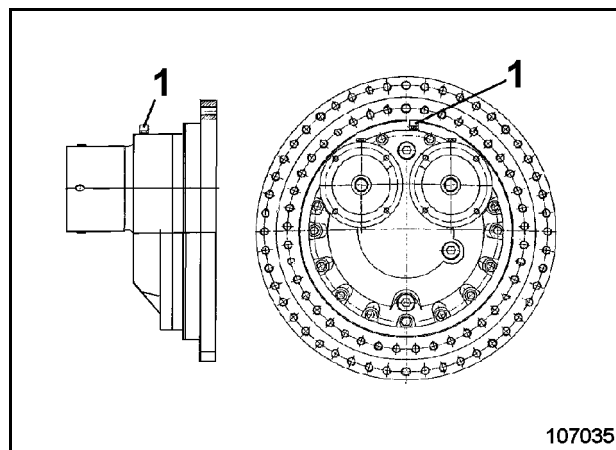

Fig. 3-134:

Checking the greasing pressure

Check every week, whether the oil pressure indicated by pressure gauge (4, Fig. 3-152:) is 60 bars / 870 psi (the pressure is depending on temperature and viscosity of the oil and may vary).

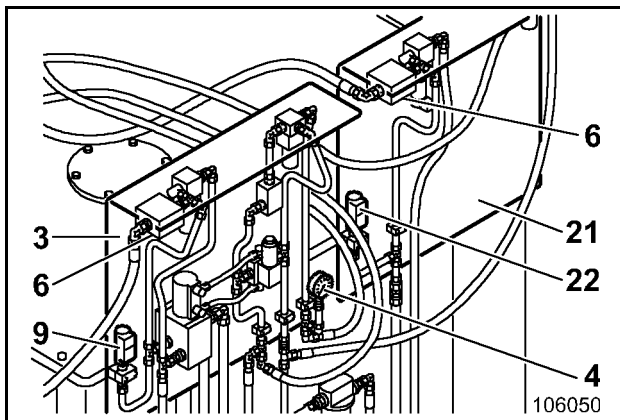

Fig. 3-152:

This oil pressure is reduced so that the pressure indicated by pressure gauge (2, Fig. 3-153:) is 35 – 40 bars / 507 – 580 psi and by pressure gauge (4) is 49 – 51 bar / 711 – 740 psi.

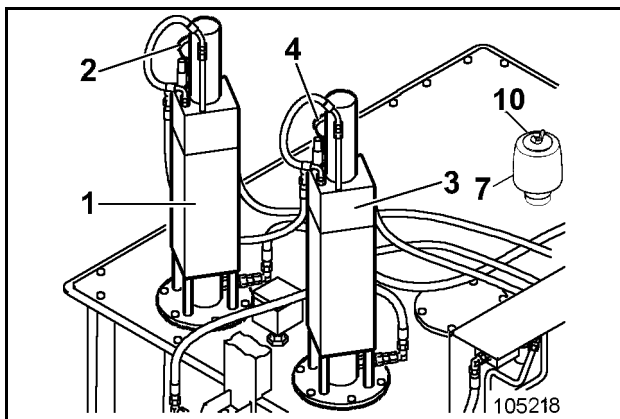



Fig. 3-153:

The necessary greasing pressure of 320 bar / 4641 psi for the superstructure and 180 bar / 2611 psi for the lower carriage is generated by means of a pressure translator.

The greasing pressure is indicated by pressure gauge (9).

In the event of deviating pressure values, shut off the engines and check the central greasing system.

Lower oil pressure means that not all of the greasing points are supplied with grease.



Higher oil pressure may cause bursting of a greasing line.

Lower oil pressure means that not all of the greasing points are supplied with grease.

Always refill the grease container in time to avoid air from penetrating into the greasing system. Air in the greasing may cause malfunctions.

Drive unit

The drive unit comprises:

- crane engine,
- hydraulic system.

Crane engine

See operating instructions for the crane engine.

- Fill up fuel tank through filler (5, Fig. 3-167:) after each deployment.
- Prior to each deployment check the engine oil level with the dipstick; top up if necessary.
- regularly, at least once a year
 - change engine oil,
 - replace engine oil filter,
 - check / replace air filter,
 - replace fuel filter.
- Check batteries (7) and cable connections at regular intervals.

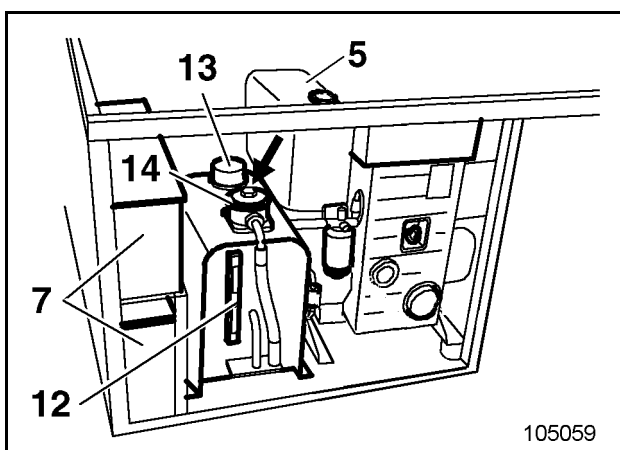

Fig. 3-167:

Air-intake system

Never start up the engine when the air filter is removed.

Hydraulic system

See crane operating instructions.

- Prior to each deployment, check the hydraulic oil level at the inspection glass (12, Fig. 3-167:); top up if necessary.
- Check contamination of hydraulic oil filter regularly at contamination indicator (arrow, Fig. 3-167:).
- Regularly, but at least once a year replace the hydraulic oil filter (14) and the breather filter (13).

On-board crane

Servicing

- Lubricate all bearings regularly and as required, and spray swing ring with a graphite spray (Fig. 3-168:):

1 -	bearing	4 lube points
2 -	joint (column/boom)	2 lube points
3 -	cylinder bearing	5 lube points
4 -	swing ring	

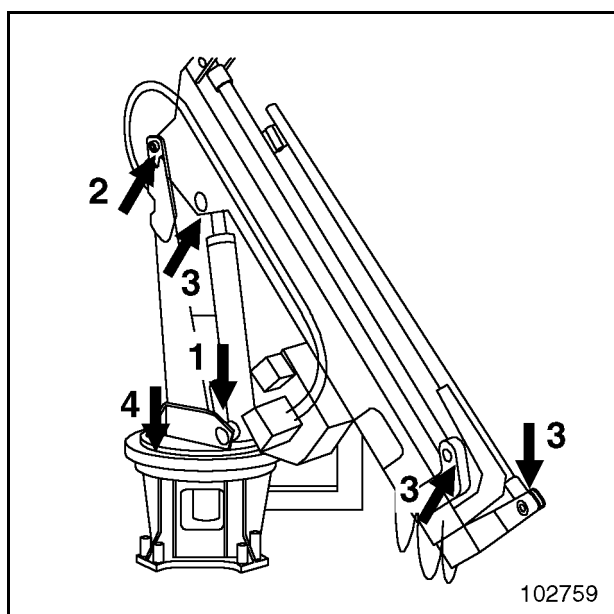

Fig. 3-168:

REPAIR WORK, FIRE AND EXPLOSION HAZARD



Safety instructions

Prior to commencing work, obtain information on the national and corporate rules for the prevention of accidents and avoiding fires.

Pay particular attention to hazards caused by combustible and easily flammable substances.

Obtain information on the safe handling of the fire extinguishers to be used.

Avoid smoking and open fire on, next to and below the excavator.

Even battery gases can ignite in open flames or fire.

Combustible and easily or highly inflammable substances or liquids increase the risk of fire and explosion. This is also valid for pressure vessels containing flammable substances as, for instance, spray oil or cold-starting fluid (ether). They are heat-sensitive and can explode even if exposed only to intensive sunlight.

These substances can also ignite themselves if they come close to hot units or objects as, for instance, a turbocharger.

Do not store these substances on the excavator. If combustible, easily or highly flammable substances or liquids were used during maintenance operations, they must be completely removed from the excavator at the end of the work.

Avoid parking the excavator in places where

- combustible substances such as coal dust or tar are present.
- open or smouldering fire may occur.

Remove the excavator from such an area where combustible or easily flammable liquids have spilled from the excavator onto the ground.

Flying sparks (caused by welding, flame cutting, grinding, electrical short-circuit) may cause fire on the ground that can spread to the excavator.

Place suitable fire guardings (fire barriers) if open fire or flying sparks cannot be avoided during repair work.

If necessary, also cover the ground with fire-protective blankets.

Apply special protection to cables, cable ducts as well as to hose and pipe lines.

Have all your welding, flame cutting and grinding work approved before starting work.

The engine compartment can be equipped with pressure vessels containing cold-starting fluid (ether). Ether is toxic and highly flammable; the vessels are under pressure. These pressure vessels can explode if exposed to high temperatures (above 49°C / 120°F) or in the event of damage. Protect the pressure vessels against damage before beginning to work in or close to the engine compartment.

Ensure sufficient ventilation.

Do not keep any fire extinguishers that are not suitable or have not been tested.

Do not extinguish flammable liquids with water. Use:

- dry-powder, carbon-dioxide or foam extinguishing compounds.

When getting into contact with burning substances, the fire-fighting water would abruptly evaporate and distribute the substance such as oil over a wide area. Water causes short-circuits in the electrical system thus possibly entailing new hazards.

Call the fire brigade.

Clean the excavator carefully after the maintenance, if oil, grease, fuel, detergents or cold-starting fluid have been spilt over the machine. If possible, use a steam-jet cleaner for cleaning.

5 ANNEX

	Operating instructions	Target group
Part 1	INTRODUCTION FUNDAMENTAL SAFETY INSTRUCTIONS	Operating personnel + Inspection and servicing personnel + Repair personnel
Part 2	OPERATION	Operating personnel The operating personnel must have know-how relevant to the operation and the application of this or comparable machines.
Part 3	INSPECTION AND SERVICING	Inspection and servicing personnel The inspection and servicing personnel must have know-how relevant to the inspection and servicing of this or comparable machines.
Part 4	REPAIR WORK	Repair personnel The repair personnel must have know-how and experience relevant to the repair of this or comparable machines.
Part 5	ANNEX	Operating personnel + Inspection and servicing personnel + Repair personnel
Part 6	INDEX	Operating personnel + Inspection and servicing personnel + Repair personnel

ABBREVIATIONS

A	Ampere (SI base unit of electric current)
abt.	about
acc.	according to
Ah	Ampere hours (SI base unit of quantity of electricity)
API	American Petroleum Institute
approx.	approximately
BA	= OI = Operating instructions
bar	unit of pressure, 1 bar = 14.5 psi
Bh	= OH = Operating hour
CE	Communauté Européenne = European community
CECE	Committee for European Construction Equipment (Defines a measure for bucket, grab or scoop filling)
CEN	European Standardization Committee
cm	centimeter (= $\frac{1}{100}$ m)
cm ³ /rev	Cubic centimeters per revolution
CCW	counterclockwise
CW	clockwise
dB(A)	Decibel (sound intensity according to measuring method A)
dia.	Diameter
DIN	German Industrial Standard
EDS	Electronic diagnostic system
eff.	effective
e.g.	for example
etc.	etcetera
Fig.	Figure, serial number of illustration
FOPS	Falling objects protective structures
FS	Rock shovel (working equipment)
ft	foot (unit of distance), 1 ft = 0.30 meter
gal	gallon (unit of volume), 1 gal = 3.78 liters
GLR	Full-load controller (electronic module for PMS)
HD	Heavy duty
Hydr.	Hydraulic, Hydraulics
i	Transmission ratio
i.e.	id est = that is
IFN	ISO service rating, blocked

Incl.	including, inclusive of
ISO	International Standardization Organization
kg	Kilogram (unit of weight), 1 kg = 2.2 lb
kg/dm ³	Kilograms per cubic decimeter (= unit of specific density)
km/h	Kilometers per hour
kNm	KiloNewtons per meter (1 kNm = 1000 Nm) = unit of torque
kW	Kilowatt (1 kW = 1.36 hp)
l	Liter (unit of volume), 1 liter = 0.26 gal
lb	pound (unit of mass), 1 lb = 0.45 kg
Lb/in ²	Pounds per square inch (= psi)
LC	Long crawler
LDA	Charge pressure-dependent full-load limiter
LED	Light-emitting diode
l/min	Liters per minute
LpA	Sound pressure at workplace
LS	Limited slip
LwA	Sound power level of the machine in stationary operation
m	Meter (unit of distance), 1 m = 3.28 ft
M _A	Tightening torque
mA	Milliampere (= $\frac{1}{1000}$ A)
max.	maximal, maximum
min.	minimal, minimum
min ⁻¹	Revolutions per minute
mm	Millimeter (= $\frac{1}{1000}$ m)
N	Normal, standard version
N, kN	Newton, kiloNewton (unit of force)
NLGI	National Lubricating Grease Institute (USA)
NLGI--Klasse	Consistency - lubricant classification acc. to DIN 51 818
Nm	Newtonmeter (unit of torque)
No.	Number
OH	Operating hour
op.inst.	Operating instructions
OW	Superstructure
oz	ounce (unit of volume) 1 oz = 0.03 liter

CLICK HERE TO **DOWNLOAD** THE COMPLETE MANUAL

- Thank you very much for reading the preview of the manual.
- You can download the complete manual from: www.heydownloads.com by clicking the link below



- Please note: If there is no response to CLICKING the link, please download this PDF first and then click on it.

CLICK HERE TO **DOWNLOAD** THE COMPLETE MANUAL