

**Reliability at work**



# Operating manual

**Face controller PMC<sup>®</sup>-R  
for shearer operation  
Darkov mine**

**Doc. no.: 4007 178 010 BA 00**



**Bucyrus DBT Europe GmbH**

Industriestraße 1 Phone: +49 (0) 23 06 / 709 - 0 Email: [info@de.bucyrus.com](mailto:info@de.bucyrus.com)  
D-44534 Lünen Fax: +49 (0) 23 06 / 709 - 1421 Web: [www.bucyrus.com](http://www.bucyrus.com)

CLICK HERE TO **DOWNLOAD** THE COMPLETE MANUAL

- Thank you very much for reading the preview of the manual.
- You can download the complete manual from: [www.heydownloads.com](http://www.heydownloads.com) by clicking the link below



- Please note: If there is no response to CLICKING the link, please download this PDF first and then click on it.

CLICK HERE TO **DOWNLOAD** THE COMPLETE MANUAL

---

# 2 Your safety





# Storage and transport

This chapter contains important information on correct storage and secure transport of the MCU components. Observance of the instructions and manuals will increase the service life and reliability of the system components. Reading this chapter thoroughly will also help you to make your day-to-day work easier.

## Storage

### Storing the equipment

<b>corrosion protection</b>	Components coated with anticorrosion are protected for about six months.
<b>avoid direct exposure to sunlight</b>	Protect the equipment against direct exposure to sunlight. Store the electrical equipment, electronic components and spare parts of rubber or plastic such as seals, cables and hose cables only in closed rooms at temperatures between 15°C and 25°C.
<b>moisture and dirt</b>	Protect all equipment parts from dirt and moisture. Do not remove any dummy plugs or temporary covers in particular. Avoid any damage to the plug-type connections. Use the dummy plugs and canopies if you wish to put the equipment into storage after using it.
<b>short-term storage</b>	Never store electronic equipment in the open air!
<b>long-term storage</b>	The computers should be checked after a storage period of five years since the installed battery is discharged after this amount of time. It must then be replaced. The computer should be checked and the battery replaced by DBT Automation service personnel.  The system components must be checked before use after a storage period of approximately two years to find out whether the measures taken and the type of storage have caused any damage.  Seals, hose lines and lines are subject to natural ageing even if they are stored properly. Do not continue to use these components since malfunctions and ghost functions cannot be ruled out.



#### Important!

**Make sure that incoming stock is stored separately from the old stock, notably in such a manner that computer components of the same age are stored together, to avoid conflicts between different types of programming versions.**

Make sure that display covers, keyboard protective covers and plug-type connections are not damaged during storage.

## Transport

### Before transport

#### Transport containers, dimensions and weights

Make sure you observe the technical data sheet. It provides you with information about:

- dimensions and
- weights



#### Important!

**Load and transport the components carefully with concentration. Protect yourself from injury due to falling parts by wearing gloves and safety work shoes.**



Fig. 6: System drawing sheet 2 of 3

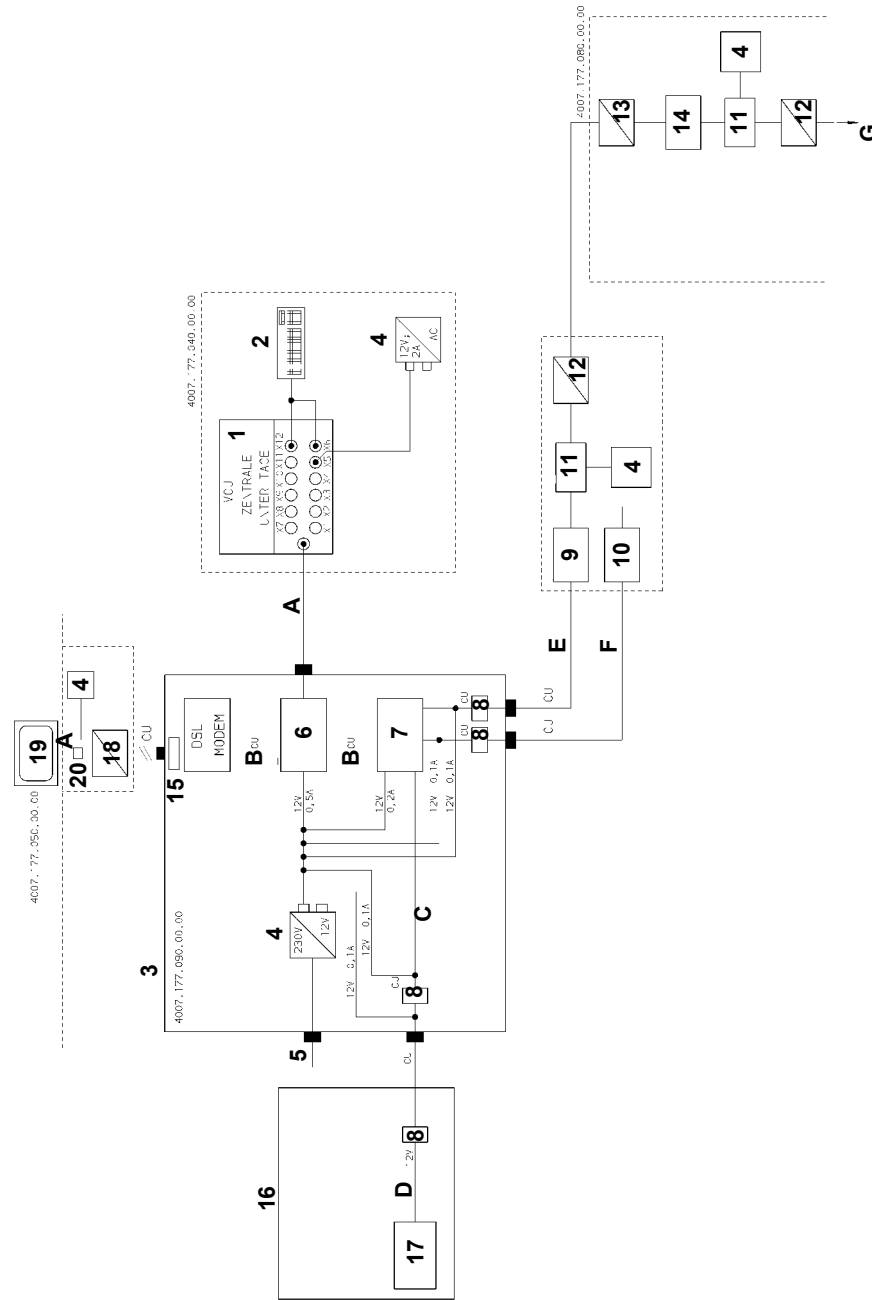

- 1 = VCU = Central underground control
- 2 = Keyboard
- 3 = OHR XP Box (see drawing 4007 177 090 00 page 4.17)
- 4 = Power supply
- 5 = Fiber-optic Ethernet cable, 10 MBit
- 6 = Switch Nitron
- 7 = PMC®-P Portux
- 8 = PMC ID BIDI RS232 coupler
- 9 = Server O1 = VCU = Central underground control
- 10 = Keyboard
- 11 = OHR XP Box (see drawing 4007 177 090 00 page 4.17)
- 12 = Power supply
- 13 = Fiber-optic Ethernet cable, 10 MBit
- 14 = Switch NTRON
- 15 = PMC®-P Portux
- 16 = PMC ID BIDI RS232 coupler
- 17 = Server PMC®-R
- 18 = PMC®-V
- 19 = Power adapter
- 20 = LD coupler, type A
- 12 = LD coupler, type B
- 13 = LD coupler, type B
- 14 = PMC®-R drive pushing device
- 15 = Barrier
- 16 = OHR XP Box see 4007 177 090 00 00
- 17 = PROLINX
- 18 = Converter PMC XDSL OPTO ETHERNET;ATEX
- 19 = FIBER-OPTIC CABLE ST-ST ADAPTER MONOMODE
- 20 = PC above ground
- A = Fiber-optic Ethernet cable, 10 MBit
- B = Ethernet
- C = Eickhoff shearer data
- D = Serial DF1 protocol
- E = Face data
- F = CST data
- G = to the first face shield

---

# 5 Operation





This is different with the function as blocking shield or shield with special function. In this case the function is assigned to the respective shield.

```
< BLK shield      yes
  20                NOM
```



Additional displays can appear in the bottom line if messages are pending. They are displayed one after the other by means of an internal information list and then removed from the list. If the corresponding message is still pending however, it is added to the list again and displayed. This display and the standard default display appear alternately.

**example:** The following messages, for example, are pending:

- Network split
- Stop

The order of the display is now in the second line:

```
"20          NOM;
SPLIT F1: x  A1: y;
20          NOM;
Cancel # x StopKey;
20          NOM
```

Each message is displayed for approximately two seconds.



**comment Z** Check the message on the display of the non-reacting PMC<sup>®</sup>-R:  
The following message can be displayed:

**G            320    316**  
**::::P M C- R ::::**

This means that the left control is disabled.

The display of the disabled control shows the letter “G” 3x because disabling the control always disables the neighbors as well.

In the event of an error, either the lock-out switch is pressed now, or the lock-out switch is defective.

**measure:** Unlock lock-out switch or exchange the control for a spare.

**VL            320    316**  
**::::P M C- R ::::**

The following causes are possible:

- PMC<sup>®</sup>-R output to the solenoid driver is defective (rare)
- Solenoid driver module is defective (rare)
- The connecting cable between the PMC<sup>®</sup>-R controls is defective (common)

**measure:** Exchange PMC<sup>®</sup>-R control unit

Exchange solenoid driver module

Exchange the connecting cable between the PMC<sup>®</sup>-R and the solenoid driver



Fig. 37: "VShield" connection display

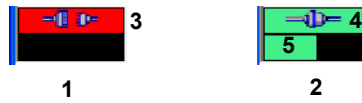

- 1 = no connection
- 2 = connection OK
- 3 = no connection from VDataDriver to VShield
- 4 = connection from VDataDriver to VShield OK
- 5 = connection to the face OK



### Important!

Further troubleshooting according to the following pattern is only possible on the MCU 1 (PM4) central control. Troubleshooting on the new MCU 2 system (PMC-®R) is not possible.

In the event of an error, it is now possible to set jumpers at various positions.

#### Test 1: On above-ground PC:

Pull out the plug of the connection to the DÜSE above ground.

Set a jumper at the 9-pin D-Sub connection between pins 2 and 3. With this jumper, the communication status line should display 1 = connection ok.

#### Test 2: On the cable between PC and DÜSE above ground

Pull out the plug to the DÜSE above ground. Input UDI/GN: Set jumper at 25-pin D-Sub plug between pins 2 and 3. Check the status window.

#### Test 3: On the DÜSE above ground:

Disconnect cable. Set bridge between terminals 1 and 9 as well as 2 and 10.

Check the status window.

#### Test 4: On the cable:

Disconnect the cable to above ground.

Set a jumper at the ends of the cable, DAa and DEa as well as DAb and DEb.

Check the status window.

#### Test 5: On the DÜSE unit: Connection space TTY

Disconnect cable

Set a jumper at the terminals +DA and +DE as well as -DA and -DE.

Check the status window.



### Important!

If, when checking the status window, a 1 is displayed and in the line for receiving errors no counter increments, the data path between the last test site and the central control is OK.

CLICK HERE TO **DOWNLOAD** THE COMPLETE MANUAL

- Thank you very much for reading the preview of the manual.
- You can download the complete manual from: [www.heydownloads.com](http://www.heydownloads.com) by clicking the link below



- Please note: If there is no response to CLICKING the link, please download this PDF first and then click on it.

CLICK HERE TO **DOWNLOAD** THE COMPLETE MANUAL



Safe distance for conveyor push sequence (bankpush)

Fig. 43: Shearer running batch 4

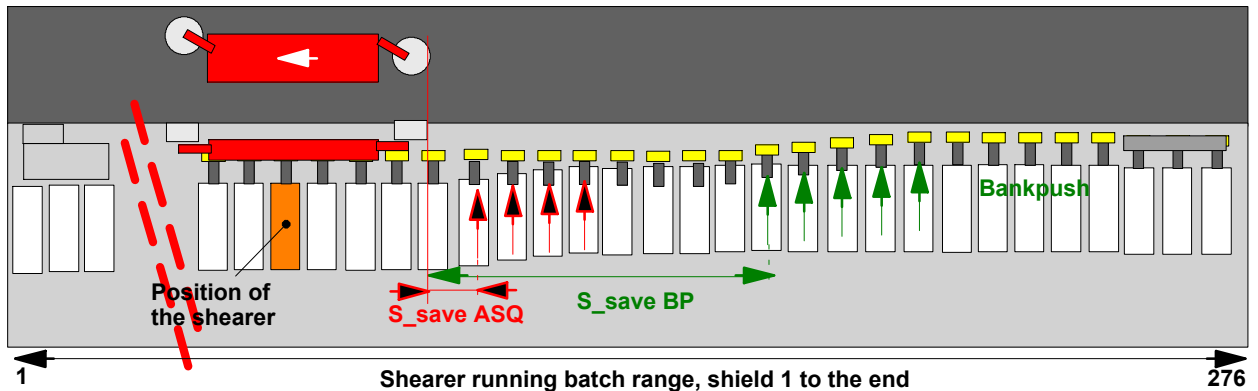

The safe distance for “Conveyor push” (bankpush) is defined like the safe distance for the sequence. (see picture above)

If the ctd parameters “S\_ctd Tail” and “S\_ctd Main” are set to “0”, the safety distances “S\_save ASQ” (value in picture “Shearer running batch 4”: 2) and “S\_save BP” from the shearer middle apply and they have to be selected accordingly with a larger number.

Continuation of the “Shearer running batch” function description

- shearer: The shearer makes a complete cut up to the head gate.
- support: The shields behind the shearer begin to run a sequence. The distance behind the shearer depends on the size of the “S\_save ASQ” parameter in number of shields.
- conveyor: Pushing of the conveyor follows the shields that have run a sequence, at a distance from the shearer “S\_save BP”, also to be entered in number of shields.



**Important!**  
Be sure that the parameters for the “S\_save ASQ” sequence and the “S\_save BP” pushing of the conveyor agree.

The parameters have different dependencies according to the desired shearer operation mode.

Fig. 44: Shearer running batch 5

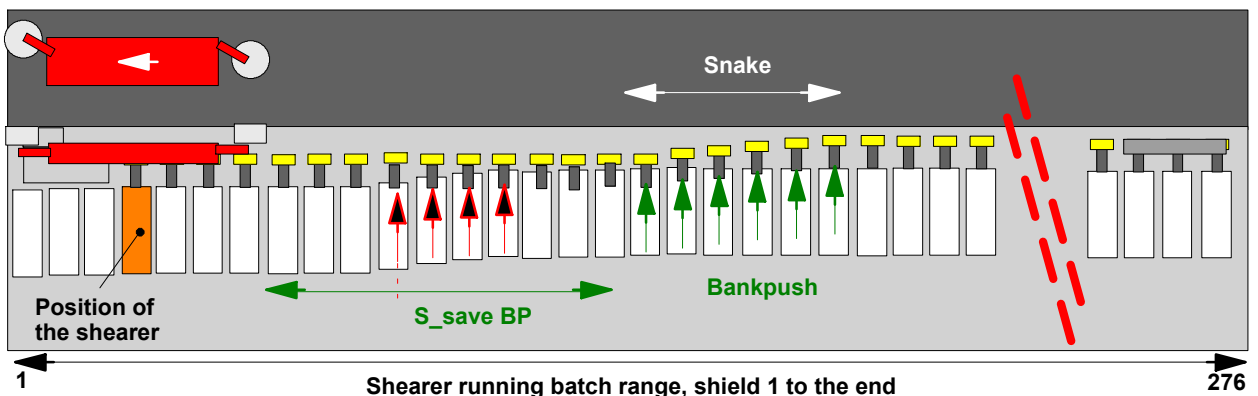

When the shearer reaches the face end and stops, the “Sequence” and “Advance conveyor” functions are stopped depending on the corresponding safe distance parameters.



## Technical data

### Face controls

In this chapter, the individual system parts of the PMC<sup>®</sup> system are shown and explained so far as necessary to understand the control system.



#### Important!

The component numbers listed in this system description are given as examples for the shown components. The numbers do not match the parts, but there are other numbers which apply to component variants, but designate the same parts externally. For this reason, the actually used part numbers may differ from those specified here. For exact identification, the valid drawings and piece lists should be used.

### Control unit PMC<sup>®</sup>-R/2

As standard, the PMC<sup>®</sup>-R control units are used on shearer or plow faces. Depending on the number of functions to be controlled on the shield, a PMC<sup>®</sup>-R can control one or several shields.

The keyboard protection cover can be exchanged by loosening the cover plate with the Allen screws, lifting up the cover plate, exchanging the cover and refastening the cover plate. This may only be done above ground in non ex-protected rooms.

The single control unit acquires measurement values such as pressure, movement and switch settings in its own shield. From this data, the PMC<sup>®</sup>-R calculates the required commands for the single shield and automatic sequence functions, and allows them to be executed by the connected electro-hydraulic valves. The PMC<sup>®</sup>-R can control and display all functions of a shield and is simultaneously the interface between operator and machine. The PMC<sup>®</sup>-R system can control all individual shield functions based on a reliable network. As an interactive system, it allows the user to execute single shield functions as well as automatic sequence functions. Important process values are continuously displayed as an acknowledgement for the operator.

Fig. 47: Example for the front view of the PMC<sup>®</sup>-R





## ExPC MCU2 central computer

The following drawing shows the explosion-proof housing which encloses the underground central control computer.

**Fig. 50: Explosion-proof central computer MCU2**

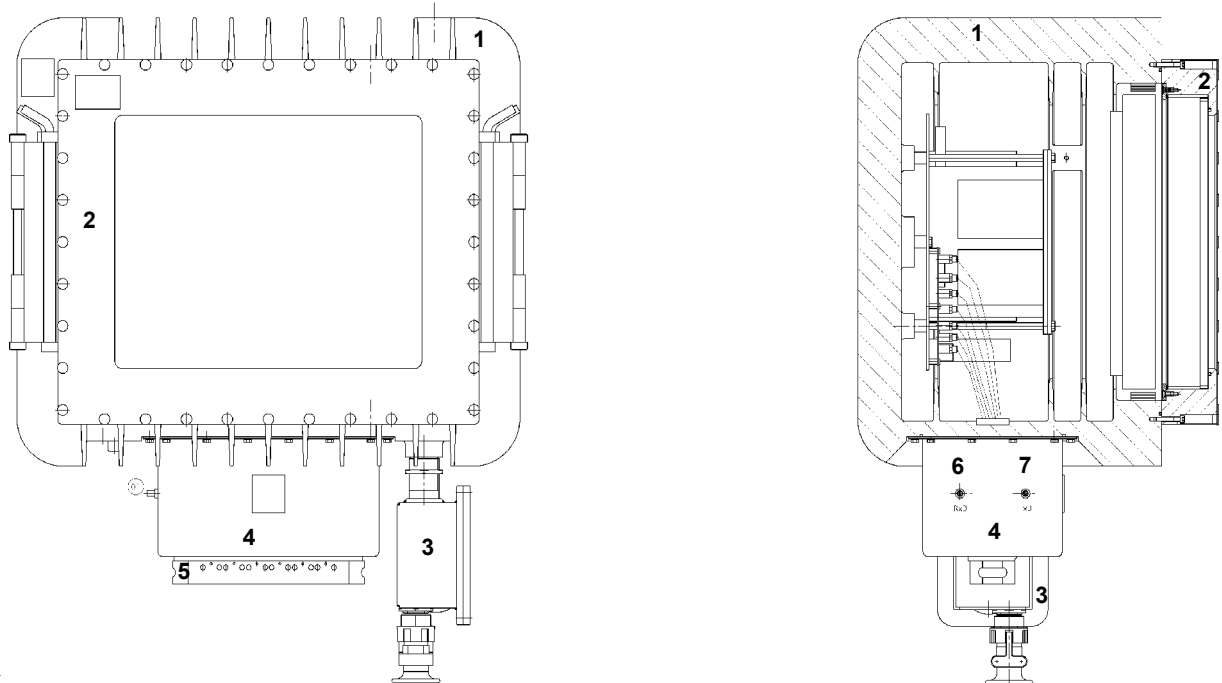

- 1 = Explosion-proof computer housing
- 2 = Housing cover with viewing window
- 3 = Terminal box
- 4 = Ports for SKK24 connectors (mouse, keyboard, server,...)
- 5 = Brass strip
- 6 = Fiber-optic cable port Rx/D
- 7 = Fiber-optic cable port Tx/D

### Device function

In a separate housing with IP 54 protection, an electronic sub-assembly for operating various serial interfaces is installed. The device is used in the Ex area for various functions. It is completely manufactured for category M2.

The next figure shows the substructure of the ExPC housing in which the keyboard operating unit with mouse are installed.

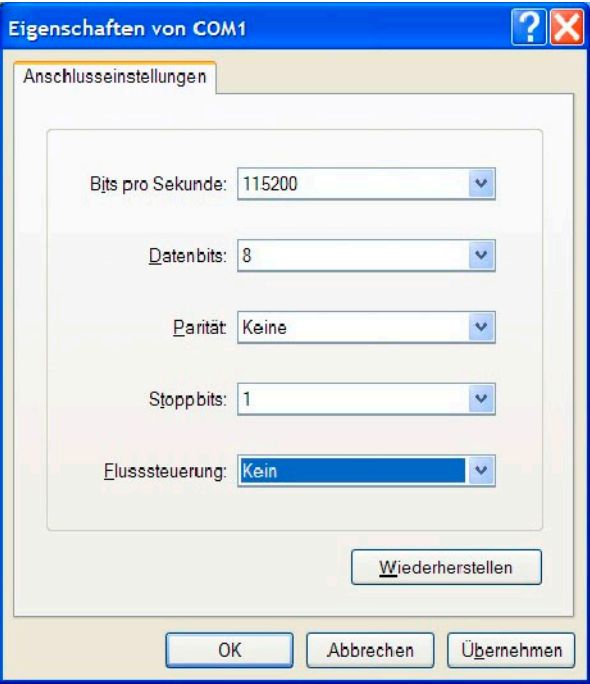

Fig. 59: Set port



Confirm the dialog box with “OK”; a new window appears, “Com1 properties”

Fig. 60: Com1 properties



The connection settings are defined in this window:



## Solenoid driver module PMC-SD1

The solenoid driver is placed at a distance from the PMC<sup>®</sup>-R, in accordance with the modular concept. The solenoid driver can switch up to 22 valves. A four-wire cable connects the solenoid driver with the PMC<sup>®</sup>-R. A switching circuit in the solenoid driver controls the data flow between the switching circuits and the PMC<sup>®</sup>-R and determines the validity of the values or announces a defect. The solenoid driver is completely covered by a 2-component resin cast. Three LEDs in the middle show the function of the solenoid driver on a continuous basis and provide the following information:

- Green LED: 12 Volts are present
- Yellow LED indicates correct data flow
- Red LED indicates an error in the data flow between the PMC<sup>®</sup>-R and the solenoid driver

Fig. 72: SOLENOID DRIVER MODULE PMC-SD1-OS4 ATEX

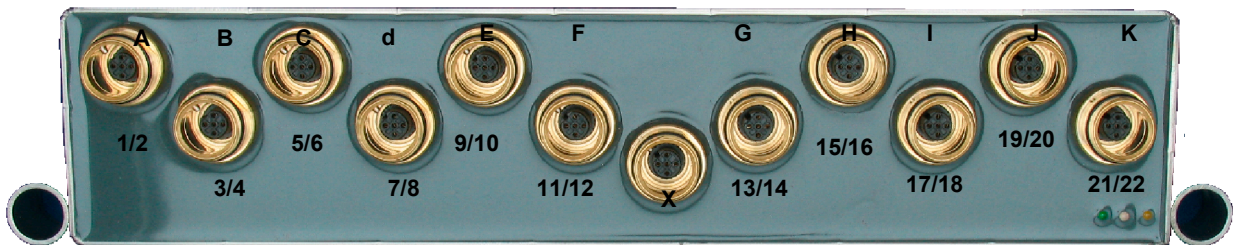

X = Connection to PMC<sup>®</sup>-R

On the solenoid driver next to the connection for the PMC<sup>®</sup>-R, there are two groups of connections:

- Connections A to F (group of 6)
- Connections G to K (group of 5)

All connections are suitable for activating double solenoid valves. The connections of the group of 5 (G - K) also allow sensor data to be read in.



### Important!

**The connecting cables to such sensors must have a crossover; they may not be connected through 1:1 (see original drawings and piece lists!)**

### Pin assignment of solenoid driver connections

(See project-specific documentation)

#### Identification:

Subject: Valve/sensor logic  
 Manufacturer: DBT GmbH  
 44534 Lünen, Industriestr. 1  
 Designation: PMC/ASL\*  
 Purpose: Intrinsically safe control of valves and sensors.

There must be writing on the valve/sensor logic which is permanently legible and has the following minimum specifications, whereby the CE-marking is at least 5 mm high.



### Identification DAN:

Subject: Pressure sensor  
 Manufacturer: DBT Automation GmbH  
 44534 Lünen, Industriestr. 1  
 Designation: DAN 602\*  
 Purpose: Measuring system pressures

There must be writing on the pressure sensor which is permanently legible and has the following minimum specifications, whereby the CE-marking is at least 5 mm high.

Name and address of the manufacturer

Type: DAN 602\*

Type of protection:  I M2 EEx ib I

Identification:  0158

Certificate number: DMT 02 ATEX E 022

Serial number: XXXX XX XXXX  
 5th and 6th places correspond to the year of manufacture

Type of protection: EEx ib I in acc. with:

EN 50014: 1997 +A1 – A2 General regulations

EN 50020: 1994 intrinsic safety “ i ”

### Description and function

The pressure sensor serves to convert a system pressure into a proportional electric signal for a pressure range from 0 to 600 bar. The pressure sensor is calibrated and tested for this pressure range.

### Parameters

Input voltage  $U_i$  DC 13.2 V  
 Input current  $I_i$  max. 240 mA  
 Input power  $P_i$  max. 1.6 W

### Pressure gauge PEMEX-LC

The pressure gauge PEMEX-LC from Kirchgässer is also included in the PMC system approval.

EEx ia I, or RL 94/9/EC DMT 02 ATEX E 213

A description is included in the appendix with the corresponding approval certificate.

### Maintenance notes

(For maintenance notes, see Chapter 2)



EN 50018-2000 Explosion-proof encapsulation

EN 50020-1994 Intrinsic safety "i"

### Type key

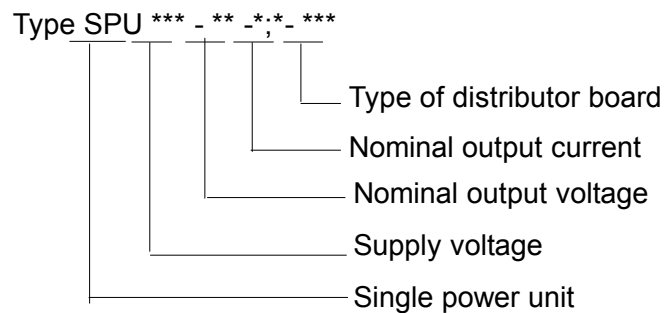

### Power circuit

SPU42-\*\*-\*,\*-\* = Supply voltage AC 19 V to 50 V; DC 18 to 70 V

SPU230-\*\*-\*,\*-\* Supply voltage AC 33 V to 276 V; DC 35 to 362 V

SPU\*\*\*-\*\*-\*,\*-\* Max. supply current AC 9 A DC 9 A

### Output circuit voltage intrinsically safe

SPU\*\*\*-12-\*,\*-\* Nominal voltage DC 12 V; max. voltage DC 12.8 V

SPU\*\*\*-05-3.2-UN Nominal voltage DC 5 V; max. voltage DC 5.8 V

### Output circuit current intrinsically safe

SPU\*\*\*-12-1.0-\*\*\* Nominal current 920 mA max. current 1.1 A

SPU\*\*\*-12-1.4-\*\*\* Nominal current 1.4 A; max. current 1.58 A

SPU\*\*\*-05-3.2-UN Nominal current 3.2 A; max. current 3.58 A

### Circuit board

SPU\*\*\*-\*\*-\*,\*-\*UN with distributor board 4008.032.011.01.00

SPU\*\*\*-\*\*-\*,\*-\*PMC with BIDI coupler circuit board 4008.004.263.01.00

SPU\*\*\*-\*\*-\*,\*-\*PM4 with BIDI coupler circuit board 4008.004.572.01.00



### Notice!

**The version with the nominal output voltage DC 5 V is only possible with the nominal current of 3.2 A and the UN circuit board.**

### Construction

The power supply consists of an explosion-proof housing and a securely fastened attachment housing with "intrinsically safe" type of protection, which are electrically connected with each other by means of an explosion-proof cable feedthrough (item X3). The following components are securely installed in the explosion-proof housing:

- Power supply (item N1)
- Terminal base (item K1)
- Test switch (item S1)
- Terminal element (item S2)
- Plug (item X9)



## LD coupler

### Coupler for long entry between Server PMC<sup>®</sup>-R and first segment shield

Fig. 101: LD coupler type A

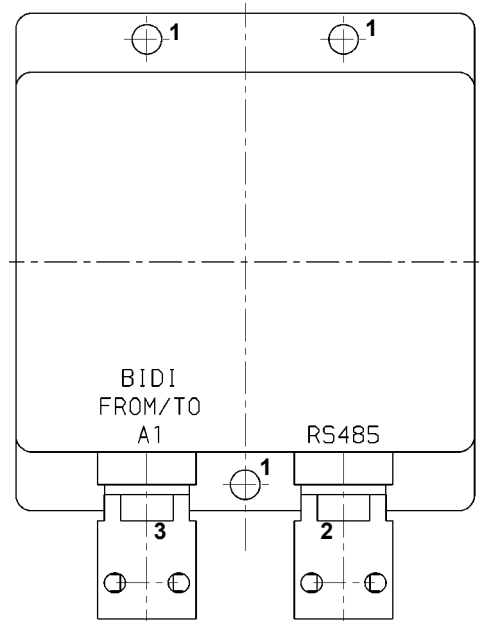

- 1 Fastening holes
- 2 SKK24 connection RS 485
- 3 SKK24 connection BIDI (marked in red)

Two different LD couplers exist for the connection between the face and the server, Type A and Type B. Type A is installed in the first segment shield, Type B in the vicinity of the server (see system drawings)

The SKK24 sockets on the LD coupler, type B, are both bronze-colored and labeled as RS485 and BIDI connections (F1) on the housing.

The RS485 interfaces of the two couplers A and B are connected with each other over the long segment to be bridged over with a four-wire control cable.

### Safety instructions

(For safety notes, see Chapter 2)

### Identification:

Subject:	Module
Manufacturer:	DBT GmbH 44534 Lünen, Industriestr. 1
Designation:	PMC-LD-*
Purpose:	Conversion of intrinsically safe BIDI signals into RS486 signals and vice versa.

A permanently legible nameplate is securely fastened to each housing with the following minimum specifications.

CLICK HERE TO **DOWNLOAD** THE COMPLETE MANUAL

- Thank you very much for reading the preview of the manual.
- You can download the complete manual from: [www.heydownloads.com](http://www.heydownloads.com) by clicking the link below



- Please note: If there is no response to CLICKING the link, please download this PDF first and then click on it.

CLICK HERE TO **DOWNLOAD** THE COMPLETE MANUAL