



# OPERATING MANUAL

**Bucyrus America, Inc.  
30M Continuous Miner**

*Doc. No.: 312494  
Serial No.:02-07-08*



---

**BUCYRUS AMERICA, INC.  
2045 WEST PIKE STREET  
HOUSTON, PA 15342-1010**

**Phone (724) 743-1200  
FAX (724) 743-1201**

CLICK HERE TO **DOWNLOAD** THE COMPLETE MANUAL

- Thank you very much for reading the preview of the manual.
- You can download the complete manual from: [www.heydownloads.com](http://www.heydownloads.com) by clicking the link below



- Please note: If there is no response to CLICKING the link, please download this PDF first and then click on it.

CLICK HERE TO **DOWNLOAD** THE COMPLETE MANUAL

# 2 Your Safety



# 3 STORAGE and TRANSPORT

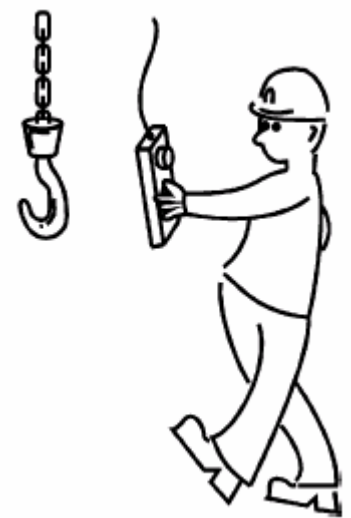



---

## Miner Start-Up



CAUTION

Do not start up and operate the miner unless all daily checks and scheduled maintenance have been completed. Do not start up the miner until any noted operational faults have been corrected.



CAUTION

Only trained and authorized operators, or trainees under a supervising instructor, should operate this miner.



WARNING

MAKE SURE, BY A VISUAL CHECK AND A SHOUTED WARNING, THAT ALL PERSONNEL ARE COMPLETELY CLEAR OF THE MINER BEFORE START-UP. Also check that any loose material, tools, oil cans or other objects are cleared from the area before starting the machine.

- Energize the main circuit breaker at the power center to enable power up to the miner.
- Turn the following manual circuit breaker handles, located on the control case and illustrated in Figure 2-1.2, to the **ON** position:
  - **MAIN CIRCUIT BREAKER** (1000VAC power to the miner)
  - **CONTROL CIRCUIT BREAKER** (120VAC power to machine controls)
  - **TRACTION MOTOR BREAKER** (1000VAC power to the tram transformer and the dust collector fan motor)

For the following activities, the operator can refer to the radio transmitter control and operation details given in Section 2-2.

- Turn on the radio transmitter by pressing the green **TX PWR ON** pushbutton.
- Turn on the pump motor by first pressing the green **ENABLE** pushbutton, then moving the **PUMP** toggle switch to the **START** position. Listen for any abnormal sounds from the pump, which could indicate oil starvation of the pump.



Having completed the downcut, Figure 3-3.9 shows the miner sumped in about half a drum diameter at the mine bottom.

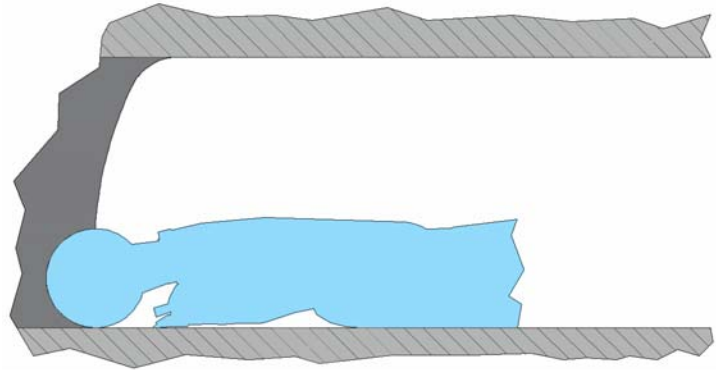

Figure 3-3.9 Miner Sumping in at Mine Bottom

Finally, Figure 3-3.10 shows the miner in the middle of the upcut.

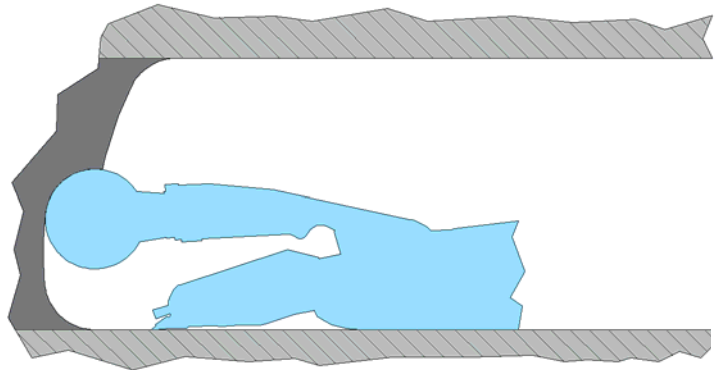

Figure 3-3.10 Miner Shearing Up

The technique of successively shearing up and down is particularly productive when the miner is working in conjunction with a continuous haulage system.

© BUCYRUS AMERICA, INC.

## MACHINE ELECTRICAL SYSTEM AND CONTROLS

It is essential for the operator to be familiar with the overall machine electrical system as well as each control element. The following provides a general description of the 30M electrical system.

Never try to hold a jumping hydraulic hose. Depressurize the line in question immediately.



- A cutting head run/lockout switch which, when in the lockout position, disables the cutting head motors. This switch is used as a safety measure when performing maintenance when the machine is under power.
- A radio/pendant control switch for enabling either the radio remote or pendant/cable control modes.

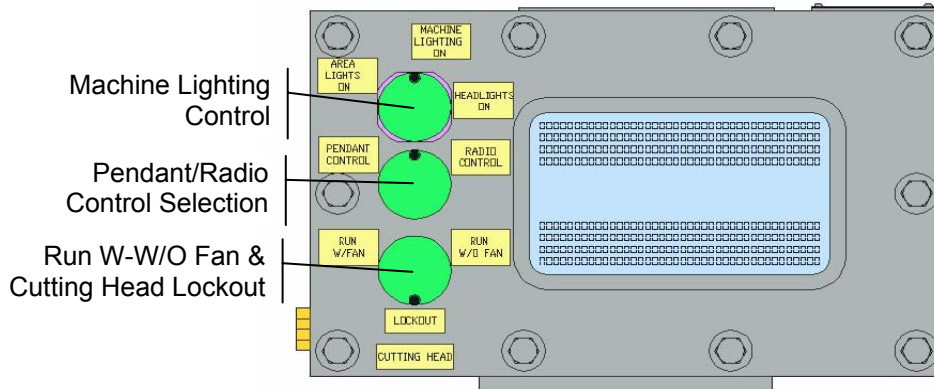

Figure 2-1.3 Display Box Details



**Table 2-2.1 Motor Controls – procedures required to run the motors (Continued):**

Code	Switch/Button	Function	Operation
7	Conveyor Start/ Stop - Return to Center Toggle Switch	Controls the conveyor and gathering motor.	Press and hold the <b>Enable</b> button, then push the <b>Conveyor Start/Stop</b> toggle switch to the <b>Start</b> position. Once the conveyor starts, release the <b>Enable</b> button and then the <b>Conveyor Start/Stop</b> toggle switch. To stop the conveyor motor, push the <b>Conveyor Start/Stop</b> toggle switch to the <b>Stop</b> position.
10	MSTOP OVR - Green Pushbutton	Ability to override an activated machine stop pushbutton	Press the <b>Enable</b> button, then press the green <b>MSTOP OVR</b> button. Hold both buttons as long as the command is required. To stop the command, release either the <b>Enable</b> button or <b>MSTOP OVR</b> button.
11	Enable Button - Green Pushbutton	Enables starting the Pump, Cutter, Conveyor, and Gathering Head motors.	Press and hold the <b>Enable</b> button and the corresponding motor toggle switch. Once the motor has started, you can release the enable button and motor switch. <b><u>NOTE: THE PUMP MOTOR WILL NOT BE ENABLED IF AN ACTIVE COMMAND IS STILL PRESENT. (TIP - LOOK AT THE SWITCH ACTIVE LIGHT TO SEE IF IT IS ON)</u></b>
13	Pump Start/ Stop - Return to Center Toggle Switch	Controls the hydraulic pump motor.	Press the <b>Enable</b> button, then push the <b>Pump Start/Stop</b> toggle switch to the <b>Start</b> position. Once the pump starts, release the <b>Enable</b> button and then the <b>Pump Start/Stop</b> toggle switch. To stop the pump motor, push the <b>Pump Start/Stop</b> toggle switch to the <b>Stop</b> position. <b><u>THE PUMP MOTOR MUST BE ENERGIZED TO INITIALIZE ALL OTHER TRANSMITTER FUNCTIONS. Only the fire sprays can be energized without the pump.</u></b>
14	Dual Tram Levers - Return to Center Levers	Left and right levers independently control the crawler direction.	Move the tram levers up to move forward and back for reverse. The tram levers must be moved within 2 seconds; otherwise the <b>Tram Enable</b> button will drop out.
15	Tram Enable - Return to Center Toggle Switch	Enables the Tram function for 2 seconds.	Push the <b>Tram Enable</b> toggle switch in either direction. The tram levers must be activated within 2 seconds or the tram will drop out. <b><u>NOTE: THE TRAM WILL NOT ENABLE IF ONE OF THE TRAM LEVERS IS SENDING AN ACTIVE COMMAND. (TIP – CHECK THE SWITCH ACTIVE LIGHT TO SEE IF IT IS ON)</u></b>
17	MANUAL FAN - - Red Pushbutton	Ability to manually run the dust collector fan	Press and hold the <b>Enable</b> button, then push the <b>MANUAL FAN</b> button. To stop the command, the pump motor must be shut down.



# BUCYRUS CONTINUOUS MINER TX-944 OPERATION MANUAL



AS PROVIDED BY:  
Cervis Inc.  
330 Perry Highway  
Harmony, PA 16037  
Phone (724) 452-3775  
Fax(724) 452-3779

CLICK HERE TO **DOWNLOAD** THE COMPLETE MANUAL

- Thank you very much for reading the preview of the manual.
- You can download the complete manual from: [www.heydownloads.com](http://www.heydownloads.com) by clicking the link below



- Please note: If there is no response to CLICKING the link, please download this PDF first and then click on it.

CLICK HERE TO **DOWNLOAD** THE COMPLETE MANUAL

**CONVEYOR STOP:** Moving the conveyor lever to the stop position will send a signal to stop the conveyor. The switch will be scanned upon startup and if held while starting up it will generate an error that will be displayed on the view screen.

**CONVEYOR START:** This action will start the conveyor. This action requires the enable button to be pressed concurrently. This lever is momentary and does not have to be held in this position. The toggle switch will be scanned upon startup. If the switch is held for more than 15 seconds an error will occur and the transmitter will issue standard motor shutdowns and display the error on the view screen.

**FIRE:** This action will start the fire suppression on the miner. The lever is momentary and does not have to be held in this position. The switch will be scanned upon startup and if held while starting up it will generate an error that will be displayed on the view screen.

**LIGHTS:** This action will activate and deactivate the lights. This function is latched function. It will turn on the lights when the toggle switch is pushed and released. If it is pushed again the light will be turned out. This switch will be scanned upon startup and if held while starting up it will generate an error that will be displayed on the view screen.

**DUST OFF:** This function will turn off the dust spray. This function is latched function. This switch will be scanned upon startup and if held while starting up it will generate an error that will be displayed on the view screen.

**DUST ON:** This function will turn on the dust spray. This function is latched function. This switch will be scanned upon startup and if held while starting up it will generate an error that will be displayed on the view screen.

**FAN OFF:** This action will turn off the fan (scrubber). This function is latched function. This switch will be scanned upon startup and if held while starting up it will generate an error that will be displayed on the view screen.

**FAN ON:** This action will turn on the fan (scrubber). . This action requires the enable button to be pressed concurrently. This function is latched function. This switch will be scanned upon startup and if held while starting up it will generate an error that will be displayed on the view screen.

**PUMP STOP:** This function will turn off the pump. This switch will be scanned upon startup and if held while starting up it will generate an error that will be displayed on the view screen.

**PUMP START:** This function will start the pump. This action requires the enable button to be *pressed before* the lever is activated. This lever is momentary but has to be held in this position for half a second before the transmitter will transfer the command. The toggle switch will be scanned upon startup. If the switch is held for more than 15 seconds an error will occur and the transmitter will issue standard motor shutdowns and display the error on the view screen

**CUTTER HEAD LOWER:** This function will lower the

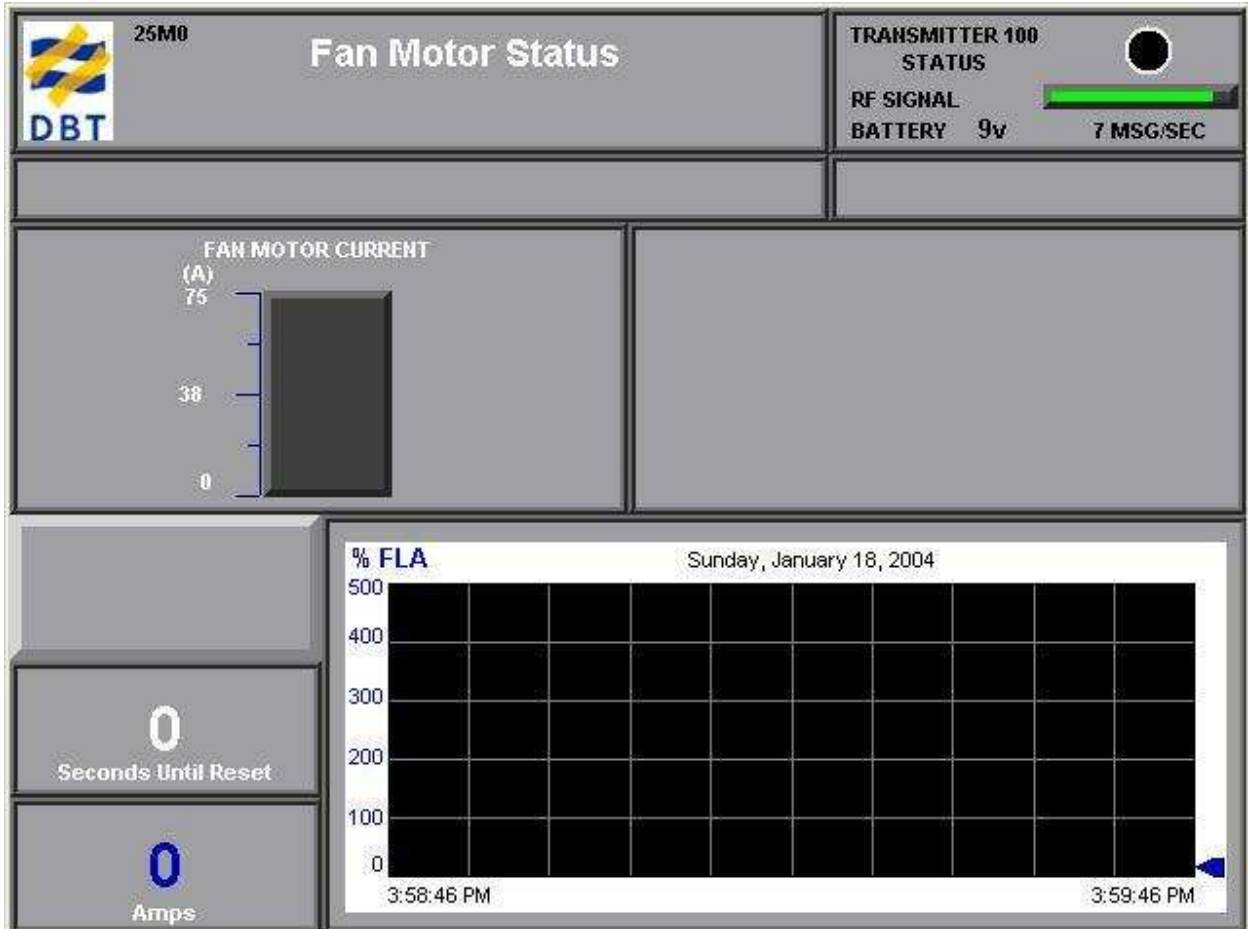

This screen gives a detailed view of the fan motor and its history for one minute. The screen will display immediately the fan motor current in the blue bar graph. In the graphics area the current will be shown from right to left, the right most side of the screen will be the most recent measurements.

The transmitter status box ie., battery, rf signal etc will be active in this screen.

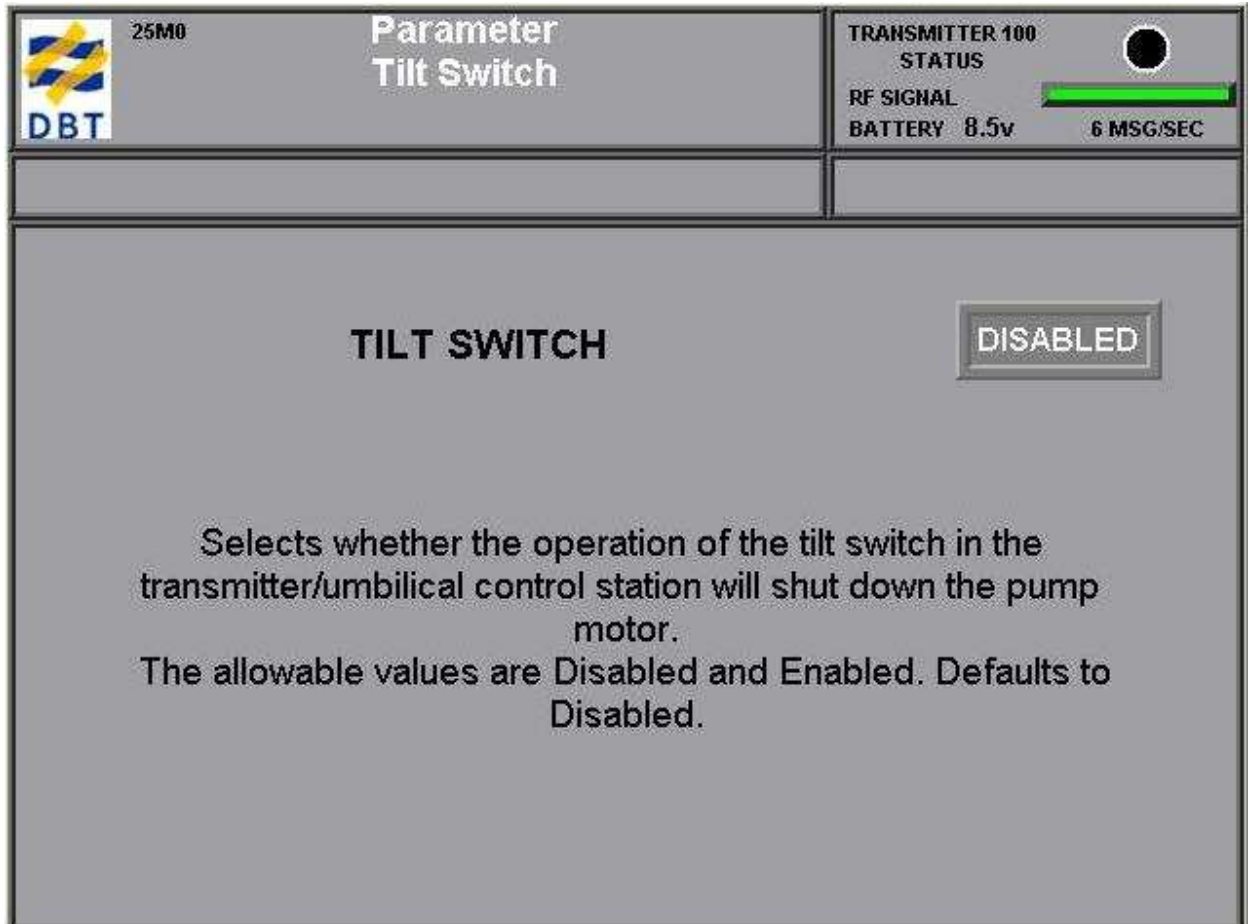

This screen is not accessible to the operator of the transmitter. The operator should be aware of the setting of this parameter. The tilt sensor always sends the signal to the MCU but is only acted upon if this menu item is set. This screen is accessible by using the IR pendant.

circuit breaker at the power center to trip rather than the onboard machine circuit breaker, if a circuit breaker is used for removing power from machine movement actuators.

The remote emergency stop device should be:

- .(1) Differentiated from other controls by size (larger) or shape;
- .(2) Located in a readily accessible, prominent location in the operator's direct field of vision on the remote controller's main control panel;
- .(3) Colored red;
- .(4) Activated by a pushing action perpendicular to the controller's main control panel surface. *Note: For example, a red, mushroom-head shaped switch actuator, may be used for this purpose, but other designs meeting the general recommendation could be used.*

The remote emergency stop device should be clearly labeled "Emergency Stop," and should be protected against the entry or buildup of coal, dust, or other foreign material that could hinder or block its activation. Ready access to the remote emergency stop device should not be hindered by the proximity of other controls or by mechanical guards. The design should consider the need for additional spacing when gloves are worn.

Operation of the remote emergency stop device should be tested during the machine preoperational checks.

Accidental Tram Activation Protection All control devices, such as buttons, levers and joysticks, used for controlling the tramming function of remote controlled machinery, should be designed such that the tramming function stops when the device is released. The remote controller actuating controls for the machine tram function should be designed to reduce the likelihood of unintentional activation. Tramming functions can be activated when cables or other material fall on the controls, or with unintentional hand or body contact. Recessed selector switches, shrouded selector switches, deadman control, two-hand control, or sequential two-switch operation such as use of a tram function enable switch should be used. These safety features should be ergonomically designed, tamper-resistant, and not interfere with the normal operation of the mining equipment.

When sequential two-switch operation (tram enable switch) is used, a tram function inactivity timer should be provided to disable the tram function if the tram controls are not activated within a pre-programmed time period. The tram function inactivity timer should be set as low as reasonably practicable, consistent with convenient machine operation. Five seconds is the recommended maximum inactivity timer setting.

The controls actuating the machine tramming function should be protected against the entry or buildup of coal, dust, or other foreign material that could hinder or block their activation or movement. *Note: The use of rubber boots or other effective means could be used for this purpose.*

Description.....	21				
Table	3.2	Alarm		Codes	
.....					22
Table	3.3			Warning	
Codes.....					24
Table	3.4	Informational		Messages	
.....					29
Table	4.1	System		Components	
.....					31

## List of Figures

### Figure Page

Figure	2.1	MCU944	Custom	PLC	Status	LEDs
.....						3
Figure	2.2	TX944	Transmitter		Status	LEDs
.....						13
Figure	2.3	RX944	Receiver		Status	LEDs
.....						17
Figure	2.4	CPS944	Power	Supply	Status	LEDs
.....						18
Figure	2.5	DCD100	DC	Tram	Drive	Status
.....						19
Figure	3.1	Display		Screen		Messages
.....						21
Figure	4.1	Remote	Control	System	Components	Layout
.....						32

# SECTION 1. HOW TO TROUBLESHOOT THIS SYSTEM

**Table 2.2d MCU944 Status LED Description (R11 & R12)**

<b>LED Function</b>	<b>LED Loc.</b>	<b>Description</b>
REMOTE	R12-7	Active when 120VAC is present.
ANY INPUT ON R9	R12-8	Active when 120VAC is present at any input on connector R9.

**Table 2.2e MCU944 Status LED Description (R13 & R14)**

<b>LED Function</b>	<b>LED Loc.</b>	<b>Description</b>
FIRE SUPPRESSION	R13-1	Active when fire suppression contact is closed. The fire suppression contact, when fire suppression is initiated, will stay active for 10 seconds. Controlled from transmitter.
BREAKER ON	R13-1	Active when Breaker ON contact closed. Controlled from transmitter.
BREAKER OFF	R13-1	Active when Breaker OFF contact closed. Controlled from transmitter.
+12 VDC OUTPUT	R13-1	Indicates +12V I/O have power.
LOW OIL LOCKOUT	R13-1	Active when low oil lockout input sensor is active.
LOW OIL ALARM	R13-1	Active when low oil alarm input sensor is active.
SPARE DC INPUT	R13-1	Unused
+5.0 VDC TO TRAM LEVERS	R14-1	Indicates +5V I/O have power.

4	Battery voltage.
5	Transmitter serial number.
6	Commanded input message indication.
7	Messages per second from transmitter.
8	RF signal strength.
9	Active input indicator.

### 3.1 Coded Alarms and Warnings

Alarms and warning codes are distinguished by the prefix letter **A** and **W**, respectively.

#### 3.1.1 Alarm Codes

Refer to Table 3.2 for the descriptions of system **ALARM** codes.

<b>Table 3.2 Alarm Codes Code</b>	<b>Description</b>
A001	Backplane Transfer Fault: CPU to PWM/Tram PCB
A002	Backplane Transfer Fault: CPU to Relay Card 1
A003	Backplane Transfer Fault: CPU to Relay Card 2
A004	Backplane Xfer Fault: CPU to Motor Current Analog Card
A005	Backplane Transfer Fault: CPU to RTD Analog Card
A006	Relay Output Error Relay Card 1
A007	Relay Output Error Relay Card 2
A008	Relay Output Error Relay Card 3
A010	Enable PushButton Stuck
A011	Transmitter shutdown Low battery
A012	Transmitter shutdown Inactivity period expired
A013	Transmitter shutdown Data link loss
A017	Pump shutdown LOW OIL LOCKOUT for 5 sec.
A018	Pump shutdown Tilt Switch Active
A019	Pump shutdown Over

# SECTION 4.

## COMPONENT IDENTIFICATION

### 4.1 Remote Control System Components

The components that make up this system are listed in Table 4.1. With exception of the TX944, all other components of this radio control system are mounted on the machine and within a methane isolation barrier enclosure. The display may be mounted on the opposite side of the machine and in its own barrier enclosure.

<b>Table 4.1 System Components Component</b>	<b>Description</b>
<b>MCU944</b>	Custom PLC
<b>RX944</b>	Radio Receiver
<b>TX944</b>	Radio Transmitter
<b>CPS944</b>	Capacitor Backup Power Supply
<b>RDU944</b>	Emergency Pendant Interface
<b>DCD100</b>	DC Tram Drive
<b>Display</b>	Graphics Status Display

### 4.2 Remote Control System Components Tie-in

The basic components and their interconnections are shown in Figure 4.1. It may be necessary to use the TX944 Radio Transmitter to check the operation of the system during trouble analysis. It is assumed that maintenance personnel have been trained in the use of this equipment.



CLICK HERE TO **DOWNLOAD** THE COMPLETE MANUAL

- Thank you very much for reading the preview of the manual.
- You can download the complete manual from: [www.heydownloads.com](http://www.heydownloads.com) by clicking the link below



- Please note: If there is no response to CLICKING the link, please download this PDF first and then click on it.

CLICK HERE TO **DOWNLOAD** THE COMPLETE MANUAL