

ARX 90

TANDEM ROLLER
DEUTZ TCD3,6 L4
EU Stage V / U.S. EPA Tier 4f

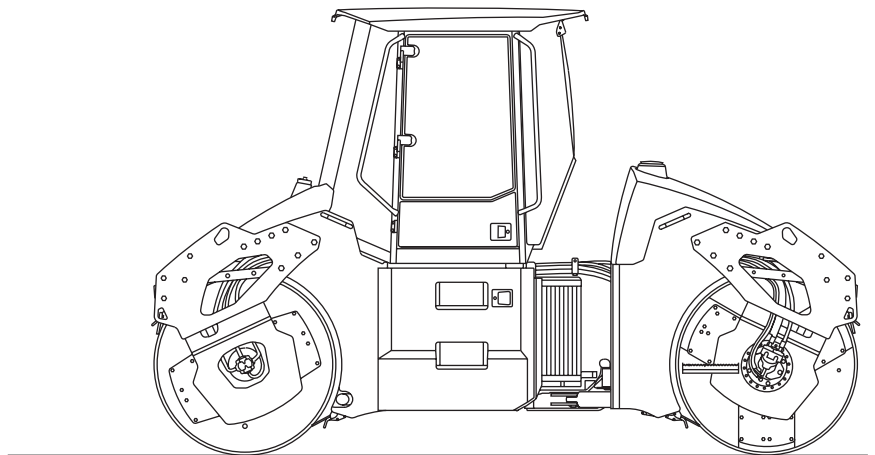

OPERATING MANUAL

EDITION 04/2022 EN
Product Identification Number 3026692 -

AMMANN

CLICK HERE TO **DOWNLOAD** THE COMPLETE MANUAL

- Thank you very much for reading the preview of the manual.
- You can download the complete manual from: www.heydownloads.com by clicking the link below



- Please note: If there is no response to CLICKING the link, please download this PDF first and then click on it.

CLICK HERE TO **DOWNLOAD** THE COMPLETE MANUAL

Every 250 hours of operation	138
3.6.17 Watering filter cleaning	138
3.6.18 Machine lubrication.....	140
3.6.19 Checking pressure in tyres	142
3.6.20 Seat switch check.....	142
Every 500 hours of operation, but at least once a year	143
3.6.21 Inspect the engine belt	143
3.6.22 Engine oil exchange.....	143
3.6.23 Inspect engine induction manifold.....	146
3.6.24 Air filter sensor check	147
3.6.25 Engine cooling liquid level check	148
3.6.26 Check of wiring.....	148
3.6.27 Cleaning the water separator	149
3.6.28 Checking the coolant level (Air-conditioning)	149
3.6.29 Engine fuel filter exchange.....	150
3.6.30 Replace air filter elements	152
3.6.31 Clean cab ventilation filter.....	154
3.6.32 Oscillation drum belt lubrication	154
Every 1000 hours of operation	155
3.6.33 Replacement of DEF (AdBlue) filter	155
3.6.34 Inspect engine cooling circuit.....	157
3.6.35 Inspect the battery	158
3.6.36 Inspection of the engine belts	160
3.6.37 Exchanging oil in gearboxes.....	161
3.6.38 Vibrations system oil exchange	163
3.6.39 Inspect the silencing system	164
3.6.40 Water tank cleaning	166
3.6.41 Air cooler cleaning.....	167
3.6.42 Engine inspection	168
3.6.43 Engine and machine diagnostics.....	168
3.6.44 Checking engine belt (Air-conditioning)	169
3.6.45 Checking the air conditioning compressor mounting (Air-conditioning).....	169
Every 2000 hours of operation	170
3.6.46 Replace hydraulic oil and filters	170
3.6.47 Vent plug replacement	174
3.6.48 Oscillation drum belt replacement.....	174
Every 6000 hours of operation	175
3.6.49 Engine coolant exchange	175

		ARX 90	ARX 90 HF	ARX 90 C
		EU Stage V / U.S. EPA Tier 4f		
Axle				
Tyre pressure	kPa	-	-	180
Number of tyres	-	-	-	4
Size of tyres	-	-	-	11,00x20''16PR
Type of tyres	-	-	-	COMPACTOR
Type of tyres	-	-	-	Tube Type
Brakes				
Operating	-	Hydrostatic	Hydrostatic	Hydrostatic
Parking	-	Mechanical multiple-disc	Mechanical multiple-disc	Mechanical multiple-disc
Emergency	-	Mechanical multiple-disc	Mechanical multiple-disc	Mechanical multiple-disc
Vibration				
Frequency I	Hz (VPM)	38 (2280) - 42 (2520)	42 (2520) - 46 (2760)	38 (2280) - 42 (2520)
Frequency II	Hz (VPM)	45 (2700) - 54 (3240)	58 (3480) - 67 (4020)	45 (2700) - 54 (3240)
Oscillation frequency	Hz (VPM)	40 (2400)	40 (2400)	-
Amplitude I	mm (in)	0,7 (0,028)	0,62 (0,024)	0,7 (0,028)
Amplitude II	mm (in)	0,34 (0,013)	0,23 (0,009)	0,34 (0,013)
Oscillation amplitude	mm (in)	1,3 (0,051)	1,3 (0,051)	-
Centrifugal force I	kN	69-84	74-89	69-84
Centrifugal force II	kN	47-68	56-70	47-68
Oscillation force	kN	77	77	-
Type of drive	-	Hydrostatic	Hydrostatic	Hydrostatic
Watering				
Type of watering	-	Pressure	Pressure	Pressure
Number of pumps	-	2	2	3
Number of filtrations	-	3	3	3
Fluid capacities				
Fuel	l (gal US)	220 (58,1)	220 (58,1)	220 (58,1)
Water for drum watering	l (gal US)	840 (221,9)	840 (221,9)	840 (221,9)
Engine (oil filling)	l (gal US)	9 (2,4)	9 (2,4)	9 (2,4)
Cooling system	l (gal US)	23 (6,1)	23 (6,1)	23 (6,1)
Hydraulic system	l (gal US)	60 (15,9)	60 (15,9)	60 (15,9)
DEF (AdBlue) Tank	l (gal US)	22 (5,8)	22 (5,8)	22 (5,8)
Vibrating drum front (oil filling)	l (gal US)	7,5 (2)	7,5 (2)	7,5 (2)
Vibrating drum rear (oil filling)	l (gal US)	7,5 (2)	7,5 (2)	-
Drum cooling liquid	l (gal US)	2x60 (2x15,85)	2x60 (2x15,85)	1x60 (1x15,85)
Washer tank	l (gal US)	3 (0,8)	3 (0,8)	3 (0,8)
Drum drive reducer	l (gal US)	2x2 (2x0,53)	2x2 (2x0,53)	1x2 (1x0,53)
Axle drive reducer	l (gal US)	-	-	2x2 (2x0,53)

2.1.4 Forbidden activities – safety and guarantee

It is forbidden to:

- Observe the machine with the engine compartment door unlocked.
- Fill the hydraulic circuit in a different way than using the hydraulic unit.
- Using the machine in case of an evident defect of the machine.
- Using the machine when any operating fluid level is low.
- Wilful repair of the engine, including peripheral engine parts – alternator, starter, thermostat, electrical installation of the engine, high-pressure injection system etc.
- Work in vibro-stroke mode in the long term!
- Operate the machine in potentially explosive atmospheres (ATEX) and underground areas.
- Quickly increase and decrease engine speed. It can damage the engine.
- Use the emergency brake for turning off the engine during normal operation of the machine.
- To use the machine following ingestion of alcoholic beverages or dopes.
- To use the machine if its operation might put its technical condition, safety (life, health) of persons, facilities or objects, or road traffic and its continuity, at risk.
- Put into operation and use the machine when other persons are within its hazardous reach – exception is training a driver by lector.
- Put into operation and use the machine when some of its safeguarding device (emergency brake, driving brake, horn, etc.) Has been dismantled or damaged.
- To roll and compact at such slopes where machine stability would be disrupted (turning over). Machine's static stability stated will lower by drive's dynamic effects.
- To roll and compact at such angles of slopes where hazard of soil breaking off (dropping) under the machine exists, or loss of adhesion followed by uncontrolled slip might occur.
- To control the machine in some other way than stated in driving manual.
- To roll and compact per bearing capacity of subsoil at such a distance from the edge of slope or trenches, where hazard of landslide or shoulder breaking off (dropping) together with the machine would occur.
- To roll and compact with vibration at such a distance from the walls, cuts, slopes, where their slip (slide) would happen and the machine covered in.
- To compact with vibration at such a distance from buildings or facilities and equipment within which the risk of them being damaged due to vibration transfer impact, would occur.
- To operate the machine unless driver control stand fixed properly.
- To move and transport persons on the machine.
- To operate the machine when within hazardous reach thereof are other machines or transportation means aside from those that operate in mutual concert with the machine.
- To operate the machine at places impossible to see from driver's stand, and where hazard to people or property could occur unless work safety has been secured through some other way like for instance via signalling by duly instructed person.
- To work with the machine at a protected zone of electric lines or substations.
- To cross electric cables if these are not properly protectedli against mechanical damage.
- To operate the machine under lowered visibility or at night, unless machine's working area and workplace are illuminated sufficiently.
- To leave driver's cockpit of the machine when the machine is running.
- Boarding or or getting off while on the run, jumping off the machine.
- Sit or stand on the outside parts of the machine when driving, or stand on the steps.
- Leave unsecured machine – move away from the machine without having prevented its misuse.
- Disable safeguarding, protective or locking systems or alter their parameters.
- Use the machine with oil, fuel, cooling liquid or other fillings leaking.
- Start the engine through some other way than given in the driving manual.
- Locate some other items (tools, accessories) aside from personal needs at driver's stand.
- Lay away material or other objects on the machine.
- Remove dirt while the machine is running.
- Perform maintenance, cleaning or repairs with the machine not secured against spontaneous move or accidental start, and when contact of a person with moving parts of the machine is not excluded.
- Contact of moving parts of the machine with human body or objects and tools held in hands.
- Smoke or handle open fire when checking or pumping fuels, refilling oils, lubricating the machine, or inspecting the accumulator or making up the accumulator.
- Carry rags soaked with flammable materials, or carry flammable liquids in free vessels on the machine (in engine bay).
- Leave the engine running in enclosed, unventilated areas. Exhaust fumes are dangerous to life.
- Drive with open doors.
- Perform any adjustments on the machine without the prior consent of the manufacturer.
- Drive without the seat belt fastened.
- Shift electrical conductors.
- Use other than original spare parts.
- Interfere in the electrical and electronic units in any manner.
- Use pressure washing near the machine control unit.



Violation of these provisions is considered a misuse of the machine in the event of an accident.

In the event of a complaint, it may affect its assessment and the further duration of the machine warranty.

2.3 Preservation & Storage

2.3.1 Short-term preservation and storage for a period of 1 – 2 months

Wash and clean the entire Machine carefully. Before parking the Machine for its preservation and storage, please warm up the engine to its operating temperature while running. Park the Machine on solid, flat surface at a safe place with no risk of natural disaster (floods, landslides, fire, etc.) to the Machine.

In addition:

- repair those spots with damaged paint
- lubricate all lubricating points, control cables, joints of the controls, etc.
- confirm water fillings are drained
- check that cooling liquid has antifreezing characteristics required
- check the state of accumulator charges, recharge them if necessary
- apply preservative grease over the chromed surfaces of piston rods
- we recommend to protect the machine against corrosion through spraying the preservation agent (applied spraying), and this in particular in places with potential of corrosion origin.

The Machine treated like that will need no special preparation prior to its subsequent putting into operation.

2.3.2 Machine Preservation & Storage for the Period Over 2 Months Long

To park the Machine the same principles will apply like at short-term preservation.

In addition it is recommended to:

- dismantle the accumulators, check their condition, and store in a cool, dry room (recharge the accumulators regularly)
- support the runner frame so the damping system shows minimal sag
- protect rubber elements through painting with spec. preservation agent
- inflate the tyres to a pressure required, and protect them from direct sunlight, apply preservation grease over the chromed surfaces of the piston rods
- preserve the machine via spraying with special agent, and this at places of possible corrosion origin
- blind the engine suction and discharge ports with double pe foil, and tighten this foil thoroughly with adhesive tape
- protect the headlamps, external back mirrors and other elements of external wiring through spraying a special agent and wrapping into pe foil
- preserve the engine per manufacturer's instruction manual – mark visibly the engine has been preserved.



After 6 months we recommend to inspect the condition of preservation and renew if required.

NEVER start the engine in course of storage!

In case of Machine storage under field conditions, please check the parking place whether not exposed to the hazard of flooding, and that danger of any other type is not present!



Prior to restoration of Machine operation, please wash the preservation agents away with the use of high pressure stream of hot water incl. addition of normal degreasers while observing the Instructions for Use along with ecological principles.

Carry out the dewaxing (deconservation) and washing of the Machine at places equipped with intercepting sumps to trap the rinsing water as well as dewaxing agents.

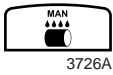

Sprinkling button (10)

Hold the button to enable the drum sprinkling function.
The function is displayed on the display (2).

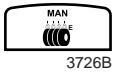

**Emulsion sprinkling button (11)
(only wheel version)**

Hold the button to enable the drum sprinkling function.
The function is displayed on the display (2).

Not assigned (12)

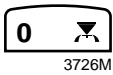

Spreader switch (13)

It serves for turning on the spreader.

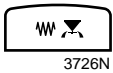

Vibrator button (14)

It serves for turning on the vibration.

Not assigned (15)



Edge cutter selection switch (16)

It is used for turning on the edge cutter (final compactor).

- Left - left edge cutter / final compactor
- Centre - OFF
- Right - right edge cutter / final compactor

For sprinkling the edge cutter (final compactor), the sprinkling pump switch (9) must be on at the same time.



Drum vibration selector switch (17)

- Left - front drum vibration
- Centre - both drums' vibration
- Right - rear drum vibration

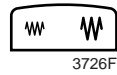

Vibration amplitude switch (18)

- Left - amplitude II switched ON
- Right - amplitude I switched ON

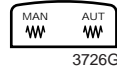

MAN / AUT vibration mode selector switch (19)

It is used to switch ON vibrations in MAN or AUT mode.

MAN - manual mode, vibrations can be switched ON even with stationary Machine.

AUT - automatic mode to switch OFF/ON vibrations



Emergency brake (20) pushbutton

Pressing the button activates the emergency brake of the machine. When the emergency brake is pressed, the warning symbol of the activated emergency brake appears on the display and the parking brake and battery charging indicator lamps come on.

Engine will stop and stall!



Warning horn button (21)

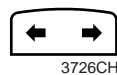

Turn indicators switch (22)

Heating exhalation



Closed



Open



409196A

Recirculation valve



Closed



Open



409199

Fire extinguisher (Optional)

Place for the installation of a fire extinguisher.



The manufacturer recommends that the machine be equipped with a fire extinguisher.



409019A

Window washer tank

Fill with standardly available media.



Fill with antifreeze or drain before winter season starts!



409185

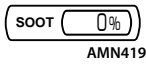

Soot level indicator

AMN419

Displays the DPF soot clogging level in %.



Coolant temperature indicator

AMN76



Hydraulic oil temperature indicator

2635

It shows the current hydraulic oil temperature.



Stop the machine and check the oil level or find a defect!



Engine lubrication pressure

AMN113

It shows the engine lubrication pressure in kPa.



Current battery voltage indicator

2777



Current fuel consumption indicator

595425



Motor speed indicator

AMN77



Engine load indicator

AMN75

It shows the current engine load in %.



Counter of engine hours actually worked

AMN73

It shows the total time, during which the machine has been in operation.



Screen changing-over

AMN66

Press the button to view the following screen for 15 seconds.
To set the following screen as the home screen, hold the button for 5 seconds.



Display backlight

AMN105

The display backlight intensity can be adjusted using the buttons.

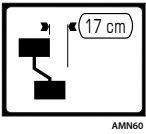

Function CRAB

The function is used for offsetting one of the drums when working at kerbs.

Drum offset

Press the button (4) to offset the front drum right.

Press the button (5) to offset the front drum left.

The drum setting is displayed on the display (2).

The maximum mutual drum offset to both sides is 17 cm (6.7 in).

Drum offset reset

Press buttons (4) and (5) to cancel the drum offset (the drums will be set in one track).



Take special care when Machine travels in CRAB mode near constructed facilities so to avoid their damage due to any collision (hitting)!

If necessary, fold the external mirrors!

2.7.7 Ammann edge cutter (optional)

Edge cutter and compacter are options supplied upon request of the customer. They are not included as standard accessories of the machine.



To additional assembly use appropriate manual.

Edge cutter plate location.

Edge cutter plate

- 1 - Name - always mentioned only in the English version
- 2 - Type
- 3 - Serial number
- 4 - Maximum weight
- 5 - Year of manufacture

How to activate the cutter

Use the switch (16) to select the edge cutter (left/right).
Use the switch (9) to turn on the sprinkling pump.



Make sure nobody is endangered when the edge cutter is started!

The buttons (7), (8) serve for setting the cutter (final compaction device) to the required position.

Upper button (7) - upward (setting to the transport position)

Lower button (8) - downward (setting to the working position)

The required position is being set while the button is pressed. After reaching the limit position in either direction, the cutter will automatically stop.

The cutting disc (A) can be replaced for the compacting disc (B).

To replace, remove the final compaction disc attachment. The not used cutting disc is to be fixed in the holder.

Note

If the cutter function is active, the vibration cannot be activated. The vibration function is deactivated.

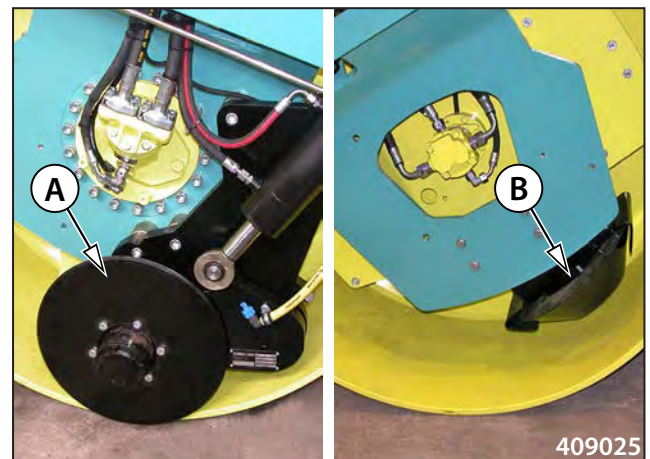
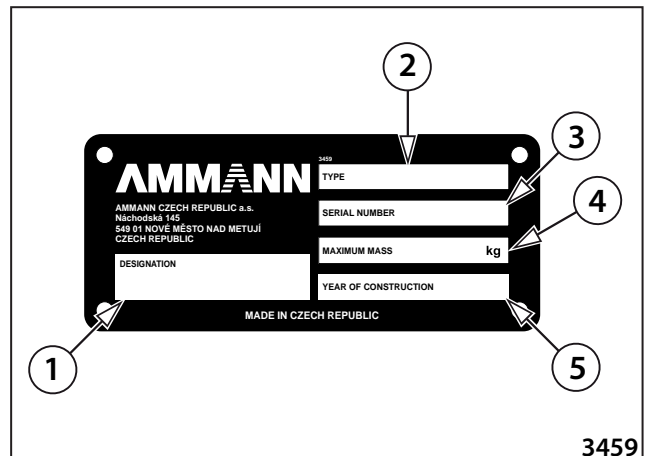
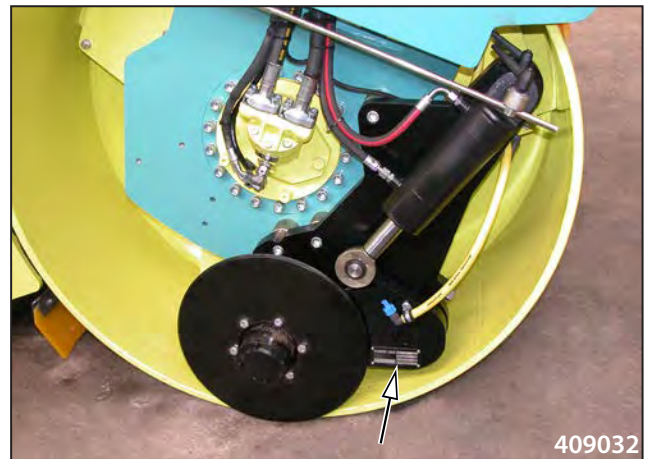

CLICK HERE TO **DOWNLOAD** THE COMPLETE MANUAL

- Thank you very much for reading the preview of the manual.
- You can download the complete manual from: www.heydownloads.com by clicking the link below



- Please note: If there is no response to CLICKING the link, please download this PDF first and then click on it.

CLICK HERE TO **DOWNLOAD** THE COMPLETE MANUAL

2.7.11.2 Double (chaotic) drum rebound

- The double drum rebound occurs when the material stiffness exceeds the applicable compaction energy of the compacting element, i.e. drum.
- During a double rebound, the drum jumps aside by more than one completed amplitude of the drum (two revolutions of the drum vibrator).
- The double drum rebound is a potentially dangerous condition which can cause damage to the machine or material being compacted. When this condition occurs, it is necessary to switch vibrations to low amplitude (when high amplitude is used) or to switch off the machine vibrations altogether (when low amplitude is used). An occurrence of this phenomenon can be caused by a change in frequency.
- The double rebound indicates that the maximum compaction rate is achieved by the given machine.
- This status is signalled by the corresponding icon on the ACE FORCE display.

Note:

If the achieved degree of compacting is not sufficient (based on a comparison with laboratory tests), a higher degree of compacting must be achieved by using a higher weight category machine or the compacting ability of the material must be checked by a certified laboratory.

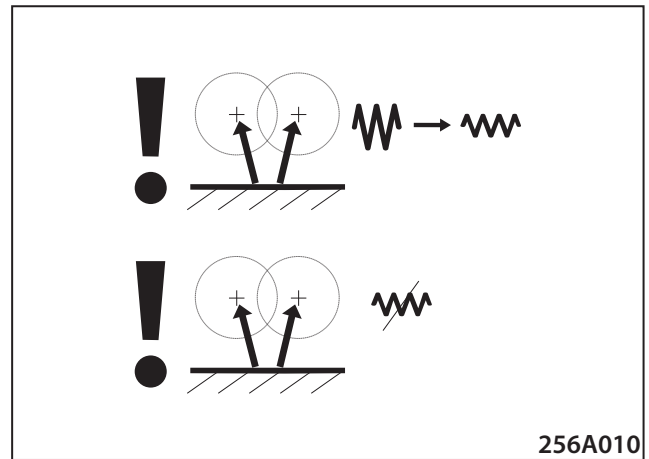



3. MAINTENANCE MANUAL

ARX 90

(Deutz Tier 4 final)

Every 500 hours of operation, but at least once a year	
3.6.21	Inspect the engine belt
3.6.22	Engine oil exchange
3.6.23	Inspect engine induction manifold
3.6.24	Air filter sensor check
3.6.25	Engine cooling liquid level check
3.6.26	Check of wiring
3.6.27	Cleaning the water separator
3.6.28	Checking the coolant level (Air-conditioning)
3.6.29	Engine fuel filter exchange
3.6.30	Replace air filter elements
3.6.31	Clean cab ventilation filter
3.6.32	Oscillation drum belt lubrication
Every 1000 hours of operation	
3.6.33	Replacement of DEF (AdBlue) filter
3.6.34	Inspect engine cooling circuit
3.6.35	Inspect the battery
3.6.36	Inspection of the engine belts
3.6.37	Exchanging oil in gearboxes *
3.6.38	Vibrations system oil exchange **
3.6.39	Inspect the silencing system
3.6.40	Water tank cleaning
3.6.41	Air cooler cleaning
3.6.42	Engine inspection
3.6.43	Engine and machine diagnostics
3.6.44	Checking engine belt (Air-conditioning)
3.6.45	Checking the air conditioning compressor mounting (Air-conditioning)
Every 2000 hours of operation	
3.6.46	Replace hydraulic oil and filters
3.6.47	Vent plug replacement
3.6.48	Oscillation drum belt replacement

DEF (AdBlue) quantity	DEF (AdBlue) indicator lamp  AMN128	Engine failure indicator lamp  AMN47	Machine reactions
< 15 %	Lighting	no	No
< 10 %	Flashing slowly (0.5 Hz)	no	No
< 5 %	Flashing slowly (0.5 Hz)	Lighting Audible signal	No
< 5 % ≥ 10 min	Flashing slowly (1 Hz)	Lighting Audible signal	Engine output reduced by 25 %
< 5 % ≥ 15 min	Flashing slowly (2 Hz)	Flashing Audible signal	Engine output reduced by 25 %
< 5 % ≥ 20 min	Flashing slowly (2 Hz)	Flashing Audible signal	Output reduced to 50 % + engine max. turns reduced to 1300 rpm.



First aid instructions

Inhalation

Move the exposed person to fresh air. Get medical attention if health effects occur. In case of inhalation of decomposition products in a fire, symptoms may be delayed. The exposed person may need to be kept under medical surveillance for 48 hours.

Ingestion

Rinse the mouth with water. If material has been swallowed and the exposed person is conscious, give small quantities of water to drink. Get medical attention if health effects occur.

Skin contact

Flush contaminated skin with soap water. Remove contaminated clothing and shoes. Get medical attention if health effects occur.

Eye contact

Immediately flush eyes with plenty of water, occasionally lifting the upper and lower eyelids. Check for and remove any contact lenses. Continue to rinse for at least 10 minutes. Get medical attention if irritation occurs.

General

Evacuate the victim to a safe place as soon as possible. If unconscious, place in recovery position and get medical attention immediately. If not breathing, if breathing is irregular or if respiratory arrest occurs, provide artificial respiration or oxygen by trained personnel. Maintain an open airway. Loosen tight clothing such as a collar, tie, belt or waistband. Keep the victim at rest in a well-ventilated area.

3.6.16 Check of the tightness of the fuel and hydraulic system

- Visually check the condition of the fuel and hydraulic system for leaking operating fluids or damage to individual system components (material degradation – ageing).
- Remove the identified defects.

3.6.24 Air filter sensor check

- Set the travel control to the neutral position (N) – engine idle speed.

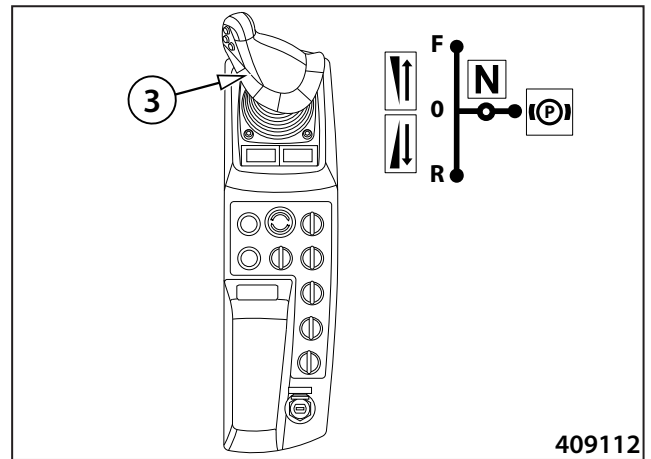

- Cover the air suction hole.



Do not use thin paper to cover it – beware of intake hole clogged!



- Once covered, the indicator lamp for air filter clogged shall light up.
- Unless indicator lamp goes ON, check the vacuum switch, contacts and feeder cables.

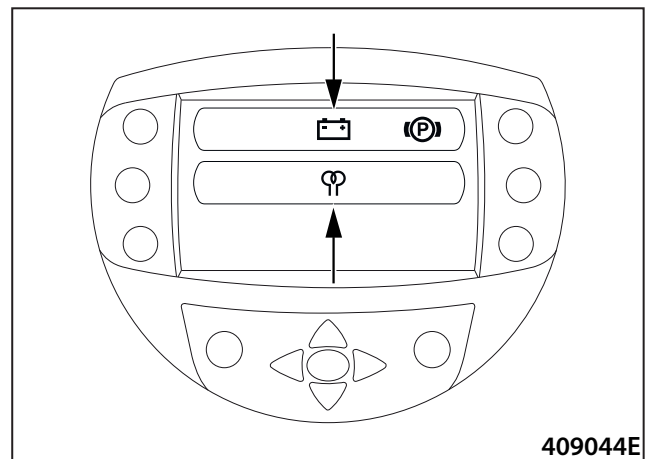

Indicator

Order number: 4-5358520057



3.6.34 Inspect engine cooling circuit

- Check the cooling circuit tightness. Confirm no pipes are damaged and no clamps are missing.

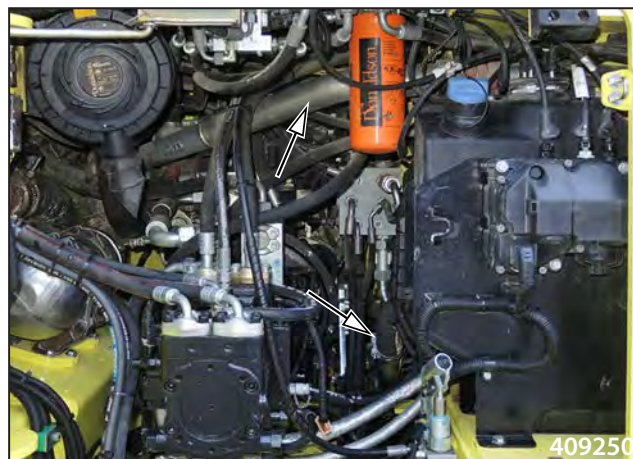

- Check the cooler fins for clogging. If the fins are clogged, then clean them, e.g. by blowing out the coolers with compressed air (steam or hot water) according to chapter 3.6.49.

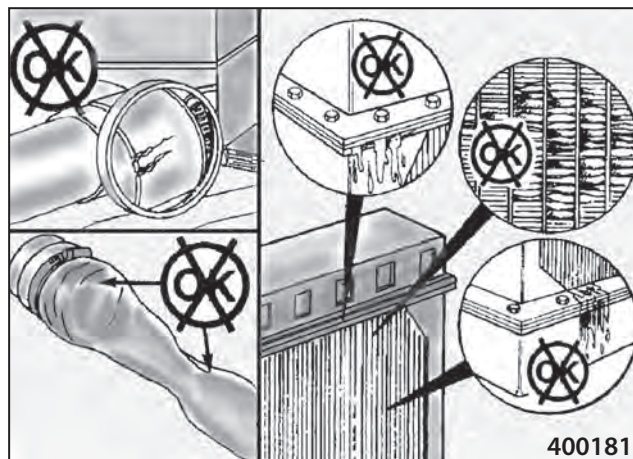

3.6.41 Air cooler cleaning

- Dismount the cover.



- Prepare a suitable vessel.
- Dismount the plugs.
- Drain the compound.
- Mount the plugs.



- Mount the cover.

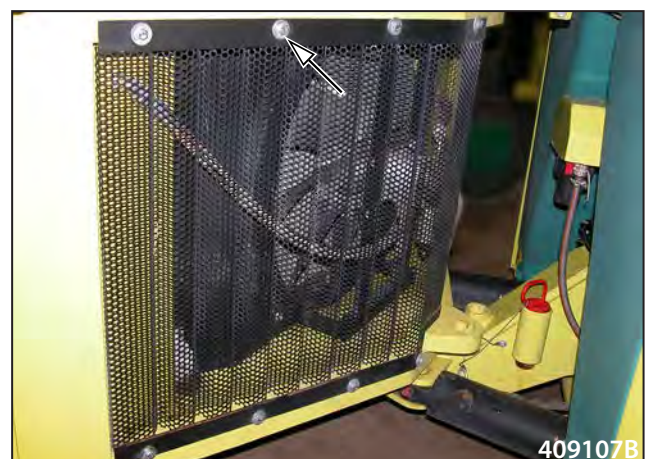

Maintenance as required

3.6.50 Deaerating (venting) the fuel system

Deerate (vent) the fuel system before the first start:

- Unless fuel filters have been filled with fuel - upon filter replacement
- Upon fuel pump replacement
- Following fuel system repair
- Upon long term shutdown of the Machine
- When having run out of fuel from the tank.

Low-pressure piping blow-off and filter deaeration:

- Prepare a suitable vessel.
- Set the key to the „I“ position.
- Loosen the bleeder screws on the fuel filter.
- Deerate the system and tighten the screw.



Do NOT bleed with the hot engine, leaking fuel may cause fire.

Follow safety regulations!

No smoking or use of open flame while at work on fuel system!



Retain any leaking fuel!

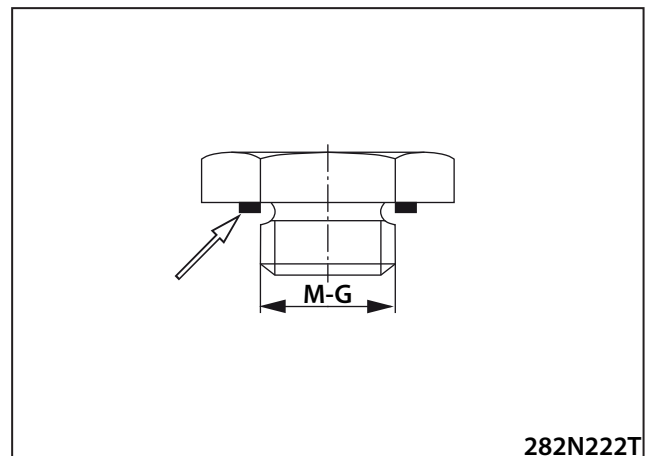
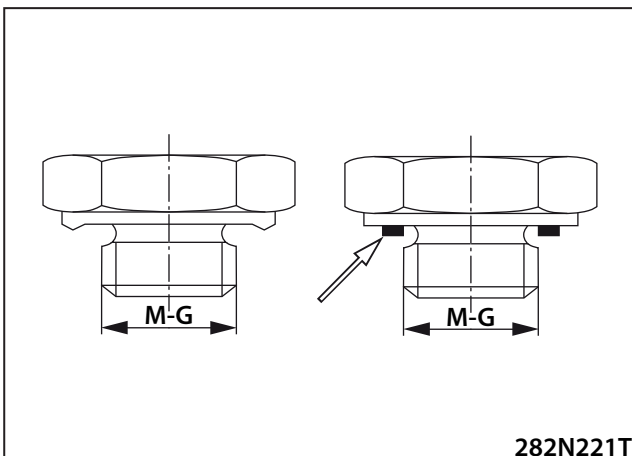

Chart showing the torques for necks with sealing edge, or with flat gasket

G - M	Tightening moments for the necks	
	Nm	lb ft
G 1/8	25	18
G 1/4	40	30
G 3/8	95	70
G 1/2	130	96
G 3/4	250	184
G 1	400	295
G 1 1/4	600	443
G 1 1/2	800	590
10 x 1	25	18
12 x 1,5	30	22
14 x 1,5	50	37
16 x 1,5	60	44
18 x 1,5	60	44
20 x 1,5	140	103
22 x 1,5	140	103
26 x 1,5	220	162
27 x 1,5	250	184
33 x 1,5	400	295
42 x 1,5	600	443
48 x 1,5	800	590

Chart showing the torques for plugs with flat gasket

G - M	Tightening moments for the plugs	
	Nm	lb ft
G 1/8	15	11
G 1/4	33	24
G 3/8	70	52
G 1/2	90	66
G 3/4	150	111
G 1	220	162
G 1 1/4	600	443
G 1 1/2	800	590
10 x 1	13	10
12 x 1,5	30	22
14 x 1,5	40	30
16 x 1,5	60	44
18 x 1,5	70	52
20 x 1,5	90	66
22 x 1,5	100	74
26 x 1,5	120	89
27 x 1,5	150	111
33 x 1,5	250	184
42 x 1,5	400	295
48 x 1,5	500	369



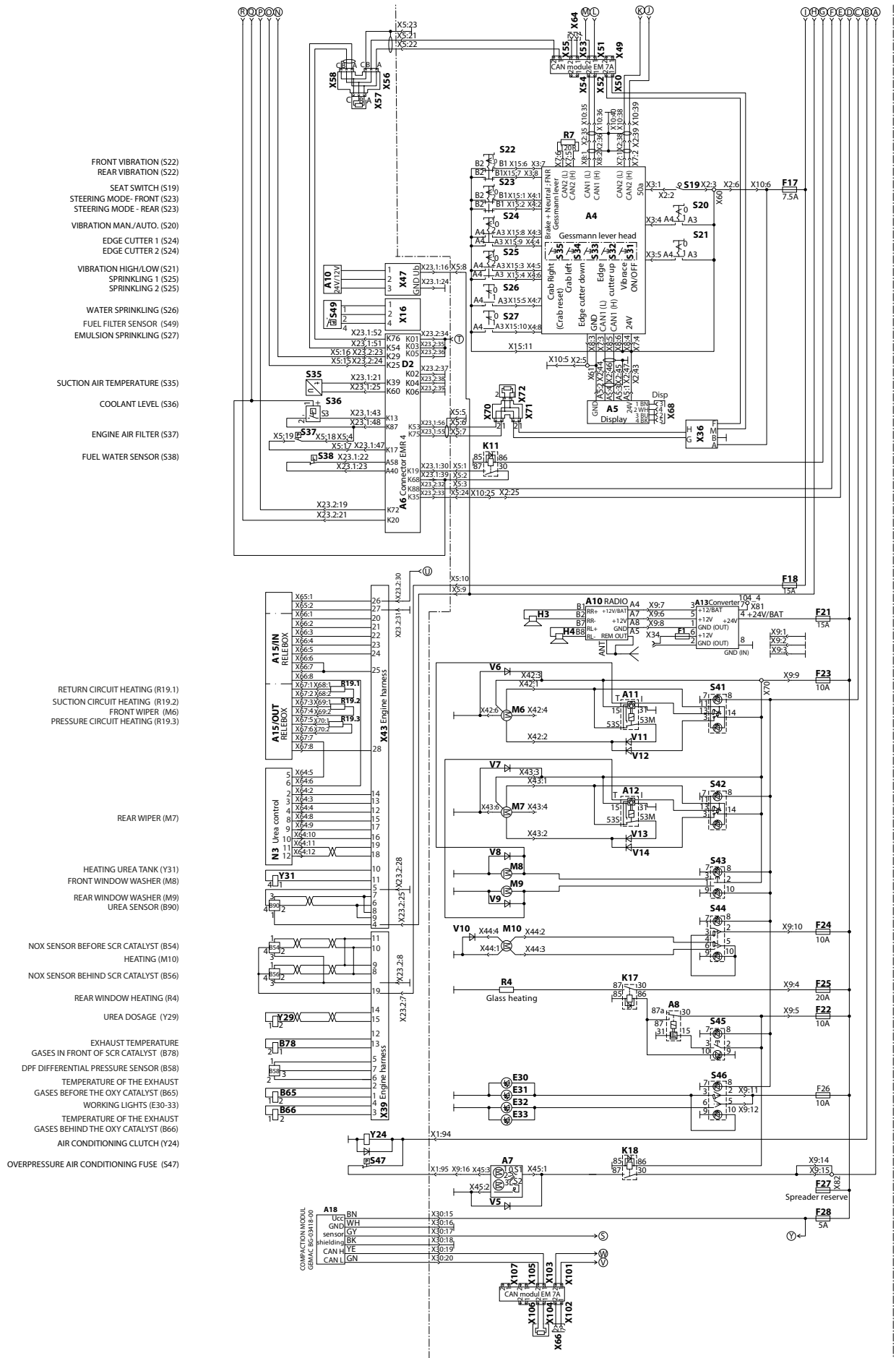

CLICK HERE TO **DOWNLOAD** THE COMPLETE MANUAL

- Thank you very much for reading the preview of the manual.
- You can download the complete manual from: www.heydownloads.com by clicking the link below



- Please note: If there is no response to CLICKING the link, please download this PDF first and then click on it.

CLICK HERE TO **DOWNLOAD** THE COMPLETE MANUAL