

ARS 200

SINGLE DRUM ROLLER

DEUTZ TCD6.1 L6

EU Stage IIIA / U.S. EPA Tier 3

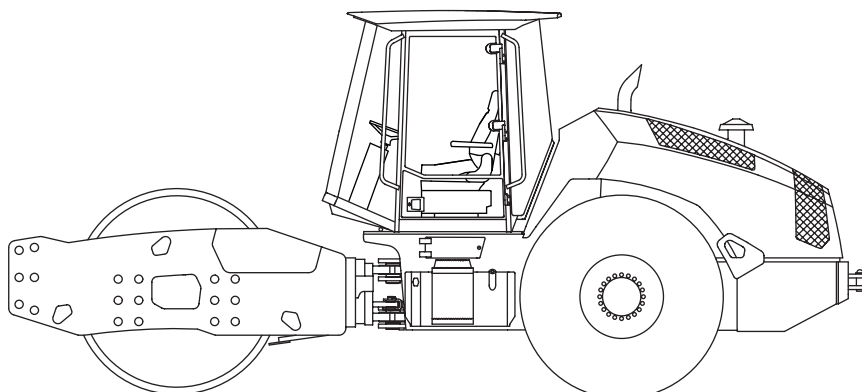

OPERATING MANUAL

EDITION 04/2022 EN
Product Identification Number 3029297 -

AMMANN

CLICK HERE TO **DOWNLOAD** THE COMPLETE MANUAL

- Thank you very much for reading the preview of the manual.
- You can download the complete manual from: www.heydownloads.com by clicking the link below



- Please note: If there is no response to CLICKING the link, please download this PDF first and then click on it.

CLICK HERE TO **DOWNLOAD** THE COMPLETE MANUAL

Every 250 hours of operation	152
3.6.14 Engine cooling circuit inspection	152
3.6.15 Air filter sensor check	154
3.6.16 Machine lubrication.....	156
3.6.17 Vibrator oil check	160
3.6.18 Travel gearbox oil check.....	160
3.6.19 Checking pad-foot segments	162
3.6.20 Seat switch check.....	162
Every 500 hours of operation, but at least once a year	163
3.6.21 Engine oil change	163
3.6.22 Engine coolant level check.....	166
3.6.23 (Air-conditioning) belt check.....	167
3.6.24 Fuel filter replacement.....	168
3.6.25 Air filter element replacement.....	170
3.6.26 Checking wheel screws for tightening.....	173
3.6.27 Cleaning the cab ventilation filter	173
3.6.28 Wiring inspection.....	173
Every 1000 hours of operation	174
3.6.29 Intake manifold inspection	174
3.6.30 Battery inspection	175
3.6.31 Engine belt inspection	177
3.6.32 Engine belt tensioner check	178
3.6.33 Travel gearbox oil change.....	179
3.6.34 Shock-absorbing system inspection.....	181
3.6.35 Engine inspection	183
3.6.36 Engine and machine diagnostics	183
Every 2000 hours of operation	184
3.6.37 Vibrator oil change	184
3.6.38 Cleaning and checking the air conditioning system	185
3.6.39 Hydraulic oil change and filter replacement.....	186
3.6.40 Cleaning the suction filter of the cab and bonnet lifting and lowering unit	192
3.6.41 Valve clearance check, adjustment	192
Every 6000 hours of operation	193
3.6.42 Engine coolant change.....	193
Maintenance - As Needed	196
3.6.43 Cooler cleaning.....	196
3.6.44 Fuel system venting	197
3.6.45 Machine cleaning.....	198
3.6.46 Scraper adjustment.....	198
3.6.47 Checking screw connections for tightening	199

	ARS 200			
	EU Stage IIIA / U.S. EPA Tier 3			
	D	HX	PD	HXPD
Optional equipment				
Air-conditioning				
Preparation for radio (box, 2 loudspeakers, antenna)				
Radio				
Additional padfoot segments (recommended with ATC and tractor tyre)				
Tractor tyre				
Vulcolan scrapers (only for smooth drum)				
ACE Force				
GPS for ACE system				
Telematic				
Night operation lighting				
Road operation lighting				
Beacon				
Back signal horn				
Fire extinguisher				
Engine pre-filter				
Special paint schema				
Biologically degradable hydraulic oil				
Set of filters, 500 h				
Set of filters, 2000 h				
Certificate of Origin				
Additional documentation				
Topcon				

2.1.5 Safety notices and signs applied on the machine

1. Pinch points



2941bz

Maintain a safe distance from the machine; there is a danger of squeezing by the machine between the front and rear frames.

2. Risk of burns



2586bz

There is a risk of burns. Do not touch hot parts of the machine unless you make sure that they are sufficiently cold.

3. Risk of injury



2409bz

There is a risk of injury. Do not touch rotating parts while the engine is running.

4. Risk of scalding



3227bz

There is a risk of scalding. Do not open the cap until the fluid cools down below 50 °C (122 °F).

5. Keep calm and adjust



2584bz

Turn off the engine and remove the key from the ignition box before maintenance or repairs are performed.

6. Read the operation manual



2702bz

Familiarize yourself with the operation and maintenance of the machine according to the operation manual!

When disposing the machine following its service life, the user is obliged to follow national waste and environmental regulations and acts. In the above cases, we recommend you to always contact:

- Specialized companies with a respective authorization for these operations.
- The machine manufacturer or accredited contracting service organizations authorized by the manufacturer.



The manufacturer shall not be responsible for damage to the health of users or environmental damage caused by the non-compliance with the above mentioned rules.

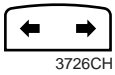

Turn signal switch (13)

3726CH



Warning lights switch (14)

3726I

It is used for turning on/off the warning lights – the function is indicated by flashing the indicator lamp in the warning light switch.

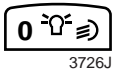

Lights switch (marker/dim) (15)

3726J

It is used for turning on/off the marker and dim lights.

Left – OFF

Centre – marker lights

Right – dim lights

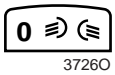

Front/Rear lights switch (16)

3726O

It is used for turning on/off the front/rear lights.

Left – OFF

Centre - front lights

Right – rear lights



Additional lights switch (17) (optional equipment)

3726L

It is used for turning on/off the additional lights.

Left – OFF

Right – additional lights of the cab

Ignition box (18)

The ignition box has three positions of “0–I–II”. The key can be inserted and removed in position “0” only.

Turn a bit the key to the right side to enable the position “I” first and then the position “II”.

The position “II” is used for starting the engine.

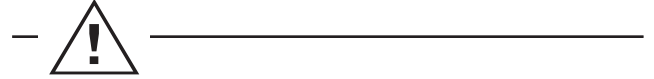

Protect the ignition box with the protective cover after the key is removed.



Connector CAN 2 (34)

It is used for connecting an external computing unit (notebook) to ensure correct communication between the engine, computer, RC display and travel control.



Connector CAN 1 (diagnostics) (35)

It is used for connecting an external computing unit (notebook) to ensure correct communication between the travel control and RC computer. After connecting to this bus using Bodas software, you can update PC, parametrize, troubleshoot, etc.



Connector ACU (diagnostics) (36)

It is used for connecting an external computing unit (notebook) Using ACE Parameter Manager software you can modify parameters in ACU or download them to PC.



Connector CAN 3 (diagnostics) (37)

It is used for connecting an external-computing unit (notebook) to ensure correct communication between ACU, ACE display and RC computer.

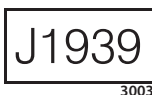

Engine diagnostics (38)

It is used for connecting to ECM (Electronic Control Module) – engine control unit and troubleshooting.

Note

ECM processes engine function data and controls the engine. Sensors pick up information about the engine function and its malfunctions and transfer them to ECM. The control unit analyses inputs and sends back commands for the engine to function properly. Failures and other engine data are identified and stored in ECM memory. The engine function and failure data are transferred after the service equipment (notebook) is connected to the socket.

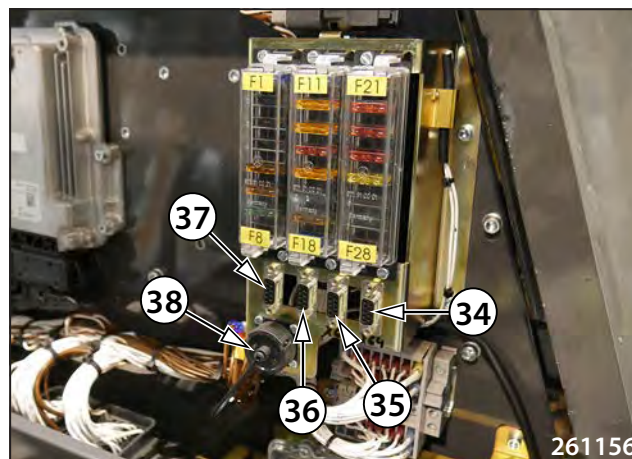



Manual vibration indicator lamp

AMN447

It indicates that the manual vibration is enabled.



Fuel gauge indicator

595425

The indicator shows the fuel level in the tank.



Fuel filter indicator lamp

AMN57

The lighting indicator lamp indicates water in the fuel filter.



Engine hour counter

AMN73

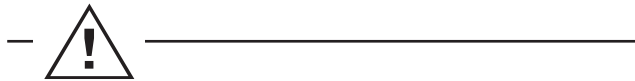

If this indicator lamp is lighting, clean the coarse fuel filter!



Vibration indicator

AMN64

The indicator shows the selected amplitude and frequency.



Turn signal indicator lamps

2489



Screen changing-over

AMN66

Press the button to view the following screen for 15 seconds.

Hold the button for 5 seconds to display the current screen permanently.



DEF (AdBlue) level indicator

595426

The function is not activated.



Soot level indicator

AMN407

It displays the soot clogging level of the SCR catalyst in %.

2.7.1 Start-up of the engine

Before starting the engine, daily check the oil level in the engine and hydraulic tanks, coolant level in the cooling circuit and fuel level in the fuel tank. Check that there are no loosened, worn or missing parts on the machine.



Start the engine only from the driver's control stand! Use the alarm horn to signal the engine starting and check that nobody is endangered by starting the engine!

Daily the machine operator must perform the brake test according to chapter 3.6.12.

Start-up procedure:

- Turn on the battery disconnecter.
- Sit down on the seat.
- Change the travel control (3) to the brake position (P).
- Check that the emergency brake (11) is not enabled.
- Insert the key into the ignition box (18) in the position "0" and switch over to the position "I".
- The unlock code prompt appears on the display (2) if the ignition lock function was enabled.
- Enter the unlock code and confirm by holding the OK button until the operation screen is displayed.
- The brake, charging, lubrication and heating indicator lamps will light up on the display.
- Wait until the heating indicator lamp goes out.
- Use the alarm horn (12) to indicate the engine starting.
- Turn the key to position "II" to start the engine.
- The charging indicator lamp must go out after the starting is completed.
- After the machine moving-off is completed, the brake indicator lamp goes out.

Note

If the start-up fails, turn the key back to the position "I". If the engine is not started up even after 3 attempts – check the fuel system.



Do not start the engine for more than 30 seconds. Wait 2 minutes before starting again.

Following the engine start let the engine idle at increased speed for 3÷5 min.

Do not let the engine idle for more than 10 minutes – longer idling can result in clogging of injectors, sticking of piston rings or seizure of valves!

If the coolant temperature does not reach at least 40 °C (104 °F), do not load the engine at full power!



When machines with ROPS 2D move across a slope with an inclination higher than 12 %, the indicator lights up and the audible signal is heard. If the inclination increases to 15 %, the vibration will be switched off.

The vibration cannot be switched on until the machine inclination decreases.

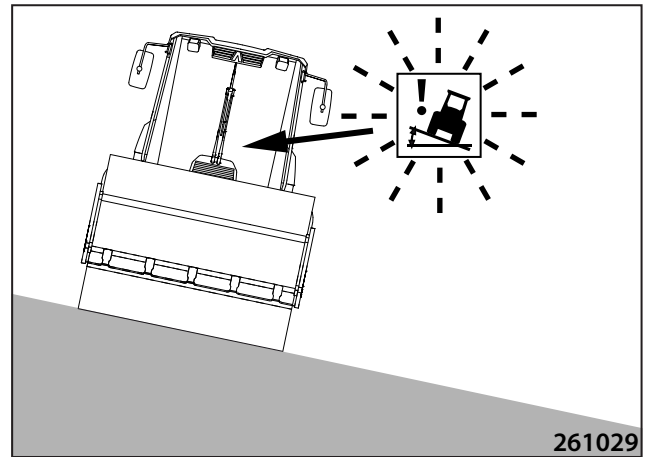

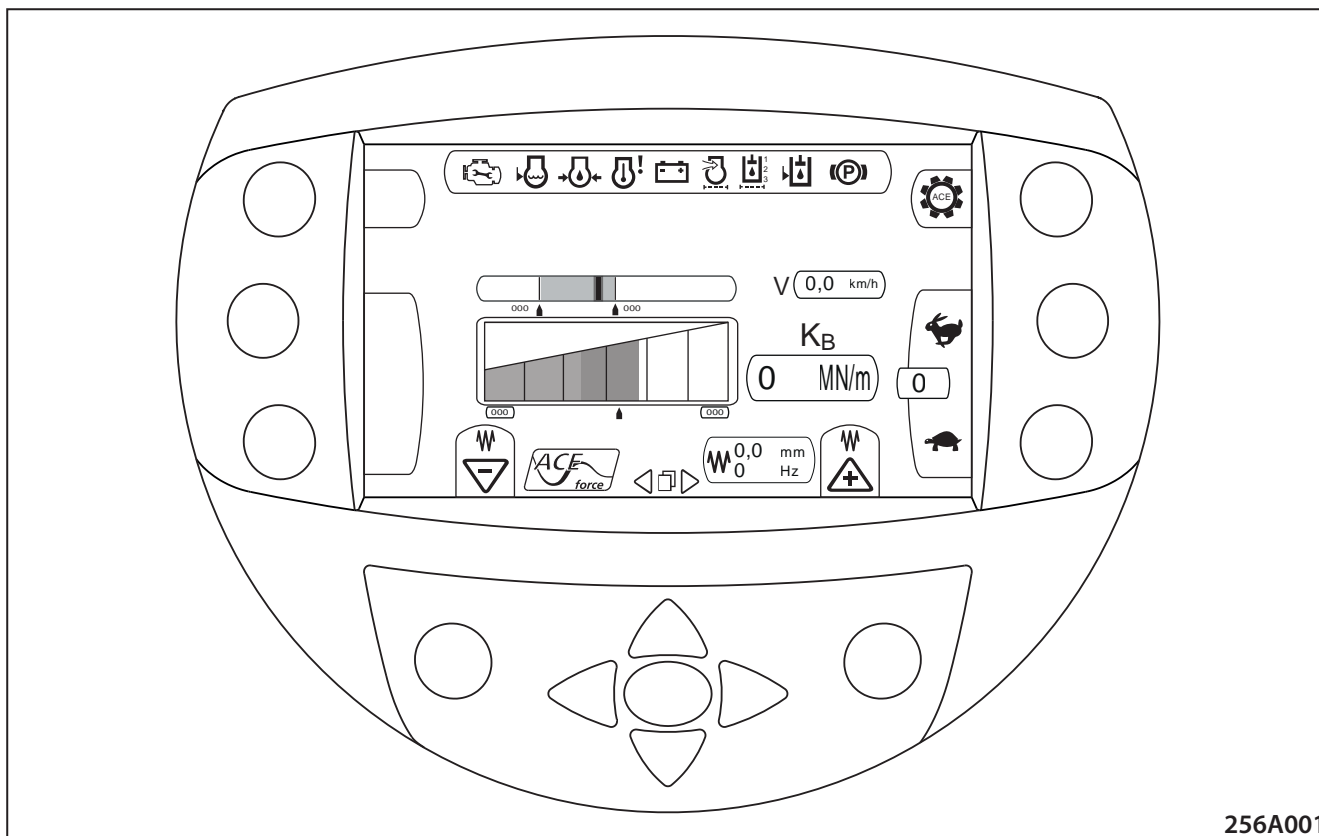

256A001

2.7.9.2 Operation screen

Operational screen of ACE Force is located as a fourth page in machine's display. The functionality of ACE Force is operated automatically, without necessity of presetting. System is activated by start of the vibration and deactivated by stop of the vibration. System shows following values and information:

Parameter	Value
Kb	MN/m
Amplitude	mm (in)
Frequency of vibration	Hz (VPM)
Speed	km/h (mph)



Engine overheating indicator lamp



Battery charging indicator lamp



Air filter clogging indicator lamp



Engine failure indicator lamp



Indicator lamp of hydraulic oil filter clogging



Coolant level indicator lamp



Indicator lamp of hydraulic oil level



Engine lubrication indicator lamp

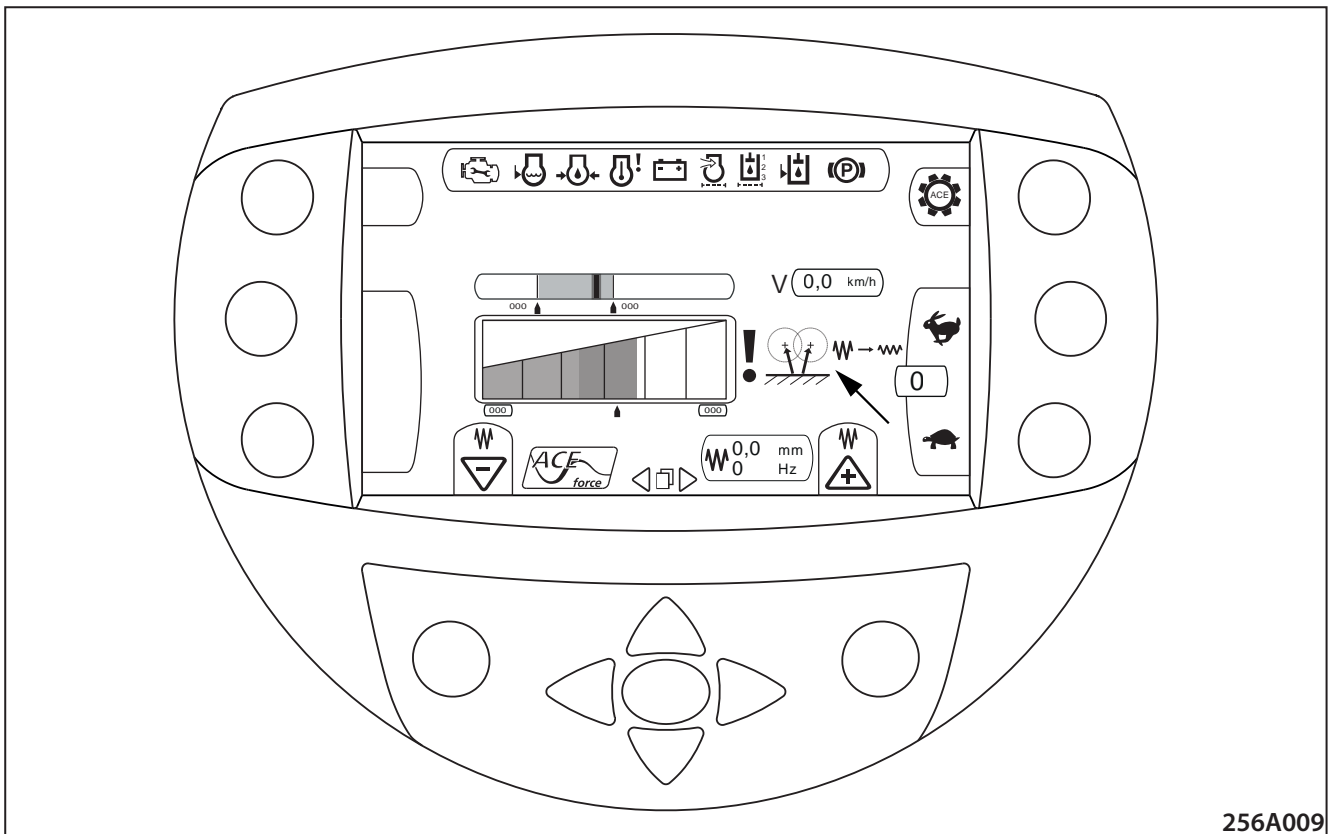

256A009

2.7.9.13 Double (chaotic) jump

A drum double jump occurs when the value of material stiffness exceeds the applicable compaction compaction energy of the compaction element, i.e. the drum.

In case of a double jump, the drum jumps by more than one finished drum amplitude (two drum exciter revolutions).

The double jump of the drum is a potentially dangerous condition which may cause damage to the machine, eventually the compacted material. Therefore, when such condition occurs, the vibration should change over to low amplitude (when using high amplitude) or the machine vibration should be turned off (when low amplitude is set). Frequency change can also influence this mode occurrence.

A double jump is an indication of the achievement of the maximum degree of compaction by the machine.

The ACE FORCE display unit indicates this condition by the icon.

Note:

If the achieved degree of compaction is not sufficient (as compared to laboratory tests), in order to achieve a higher degree of compaction, it is necessary to use a machine of a higher weight category or to check the compactibility of the material with an accredited laboratory

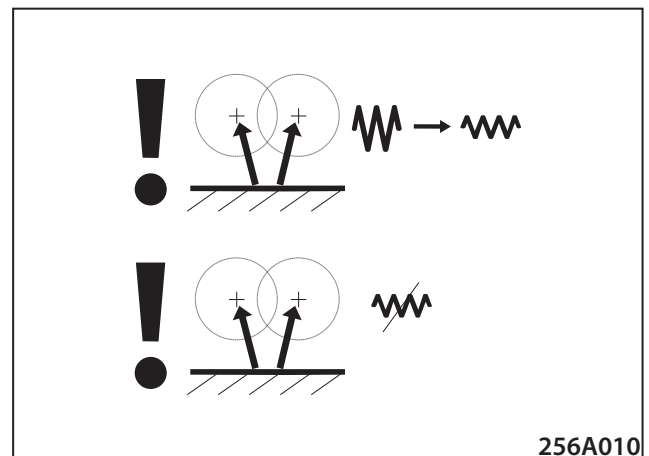

256A010

CLICK HERE TO **DOWNLOAD** THE COMPLETE MANUAL

- Thank you very much for reading the preview of the manual.
- You can download the complete manual from: www.heydownloads.com by clicking the link below



- Please note: If there is no response to CLICKING the link, please download this PDF first and then click on it.

CLICK HERE TO **DOWNLOAD** THE COMPLETE MANUAL

2.9.2 Towing the machine

- The machine is provided with two towing lugs on the front frame and with two towing lugs on the rear frame. A stuck machine can be towed for a short distance if the engine is running and the travel drive and steering are working.



The towed machine must be attached to both towing lugs.

For towing, use undamaged tow ropes or tow bars of a sufficient capacity 1.5 x higher than the weight of the towed vehicle. Do not use a chain for towing!

It is necessary to maintain the minimal deviation from the direct towing angle. The maximum deviation is possible within 30°.

The towing movement must be smooth. Do not exceed the towing speed by more than 2 km/hour (1.2 mph).

Tow the machine at the shortest distance possible – to rescue it when it gets stuck or to remove it when it is broken and obstructing. Do not tow at the longer distance than 300 m (0.19 mile).

The towing machine should correspond by its size to the damaged machine. It must have a sufficient traction force (power), weight, and brake effect.

While towing downhill using a rope, another towing machine must be connected to the rear part of the damaged machine. In this way you can prevent an uncontrolled movement of the damaged machine.

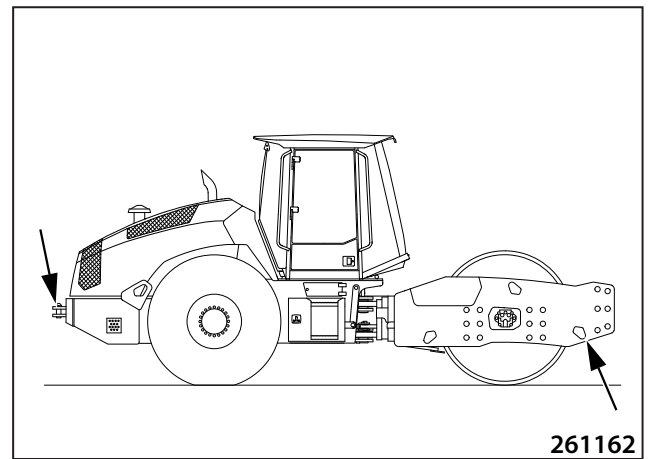

- If the engine does not work, or there is a defect in the hydraulic system, then you must short-circuit the hydraulic circuit and release the brake of the machine.
- Then the machine can be towed.



No person may be on the towed machine!

After the hydraulic circuit of the travel is short-circuited and the machine brakes are released, all of the brakes are disabled!

Before releasing the brake, secure the machine with wooden scotch blocks against movement!

Do not touch hot parts of the machine, there is a burn hazard!

3.1 Safety and other measures during maintenance of the machine

3.1.1 Safety during maintenance of the machine

Lubrication, maintenance and adjustment process:

- Charge only professionally trained personnel,
- according to safety instructions given in the operation manual for the vibratory roller,
- in intervals stated in the lubrication chart according to worked hours,
- on the machine standing on a flat and solid surface and secured against movement (with scotch blocks), always with the engine off, the key removed from the ignition box and the wiring disconnected,
- only after the tag **Machine repair** is attached on the steering wheel (the tag is delivered together with the machine accessories).
- on cold machine parts,
- after the machine, lubrication and maintenance and repair points have been cleaned,
- using suitable, undamaged tools,
- by replacing parts with new original parts according to the spare parts catalogue,
- under proper illumination of the machine while working at reduced visibility or at night,
- if the work involves removing covers and safety elements, reassemble them after completing the work,
- retighten bolted connections to the specified tightening torque and check the connections for leakage,
- after the operating fluids are heated – beware of burns – use only recommended media.



After the adjustment or maintenance is completed, check all safety devices for proper operation!

3.1.2 Fire protection when operating fluids are changed

- Considering the fire danger, the flammable liquids used on the machine are divided into the following hazard classes:
Hazard class II – diesel fuel
Hazard class IV – mineral oils, lubricating greases.
- The oil change point must be located so that it cannot interfere in the explosion or fire hazard area.
- It must be identified with “No smoking” and “No open flame” signs.
- The handling area must be dimensioned so that it can catch a volume of the flammable liquid equal to the capacity of the biggest, transport container.
- It must be equipped with portable fire extinguishers.
- For handling the oil and diesel fuel, use containers such as steel barrels, canisters, sheet metal cans.
- The transport containers must be properly closed during storage.
- The containers must be provided with one hole, always stored with the hole up and secured so that their content cannot flow out and drip off.
- The containers must be marked by non-removable writings stating the contents and flammability classes.

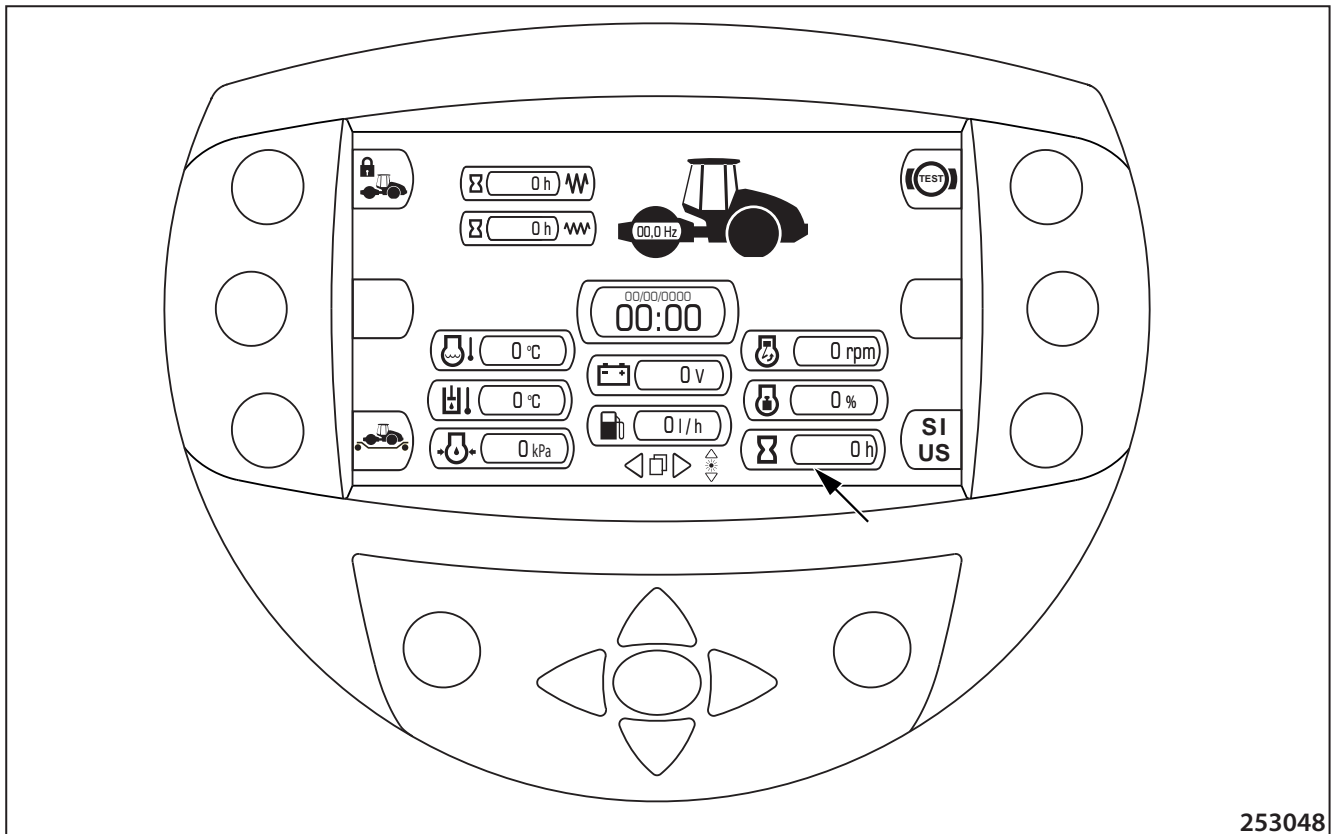

253048

Carry out lubrication and maintenance in regular intervals according to daily values on the counter of worked hours.

This manual includes only basic information about the engine, the other data are given in the operation and maintenance manual, which is a part of documentation supplied together with the machine.



Follow also the instructions given in the engine operation and maintenance manual!

Retighten removed or loosened bolts, plugs, threaded joints in the hydraulic system, etc. with the tightening torque specified in tables in the chapter 3.6.47 unless a different value is given for the respective operation.



Inspect the machine when placed on a flat and solid surface and secured against movement (with scotch blocks), always with the engine off, the key removed from the ignition box and the wiring disconnected (unless otherwise required).

After the first 100 hours of operation of the new machine (or after a general overhaul), carry out the following operations according to chapter:

- 3.6.26 Checking wheel screws for tightening
- 3.6.33 Travel gearbox oil change

After the first 500 hours of operation of the new machine (or after a general overhaul), carry out the following operations according to chapter:

- 3.6.37 Vibrator oil change

3.6.10 Engine leakage inspection

- Visually check the engine and the engine compartment for oil leakage.
- Repair identified defects.



3.6.11 Exhaust system leakage inspection

- Check the clips and pipes of the exhaust system.
- Repair identified defects.



If the exhaust piping with the flexible piece between the engine and the catalytic converter leaks or is damaged, the machine must not be operated until the defect is repaired.

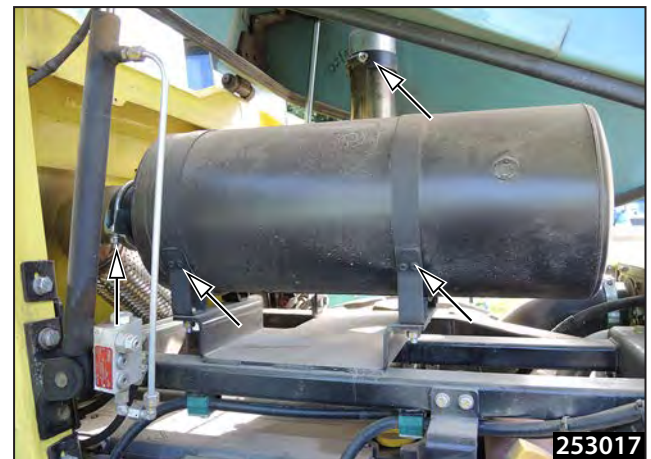

Linear hydraulic motors of steering

front pins 2x

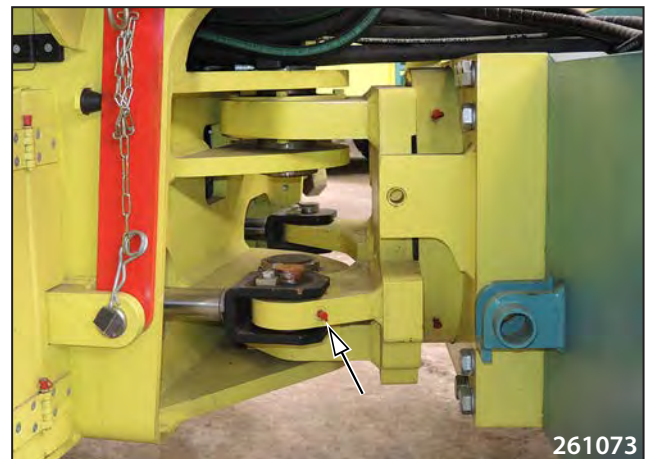
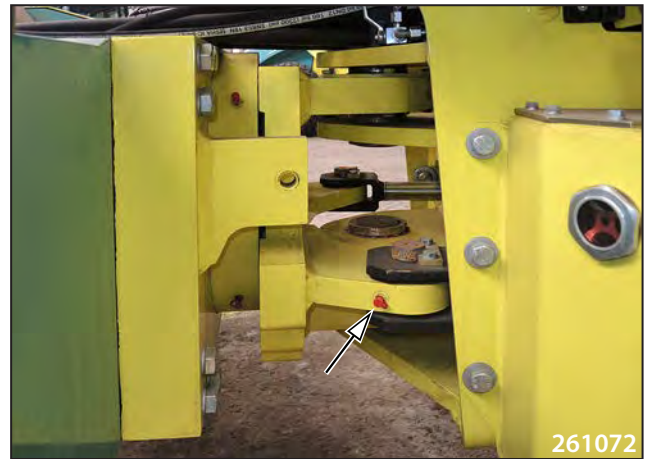

rear pins 2x



Linear hydraulic motors of bonnet lifting

upper pins 2x

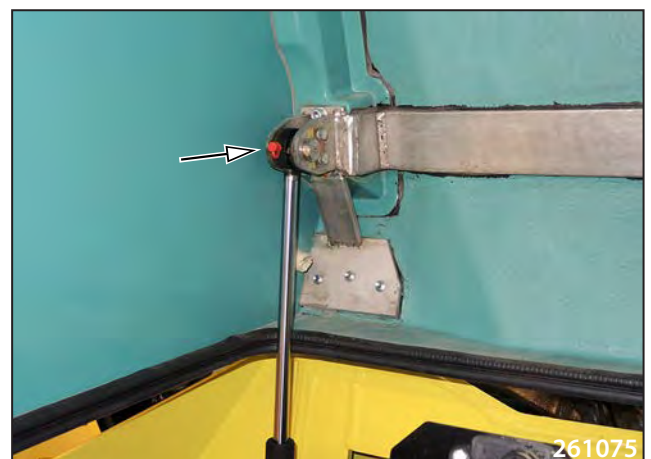

3.6.23 (Air-conditioning) belt check

Checking the air-conditioning belt for tension:

- Press with your thumb at the spot where the belt length between the pulleys is the longest, using the 110 N (25 lb) force.
- The max. slack is 10 mm (0.39 in).

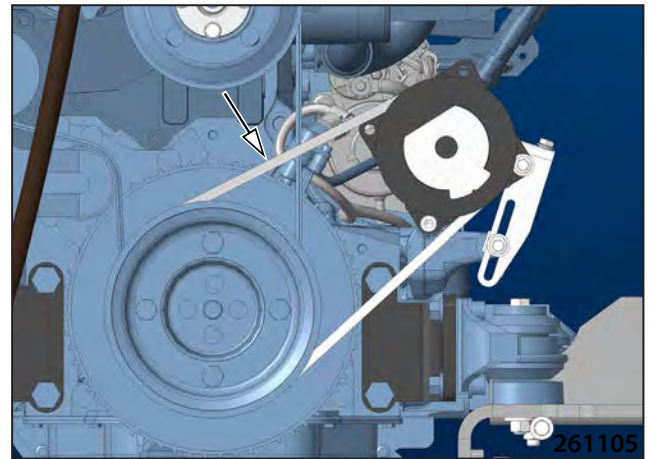

Checking the air-conditioning belt for wear:

- Visually inspect the belt.
- If longitudinal cracks appear on the belt, or the belt edges are ragged, or some material parts are pulled off, then the belt must be replaced.

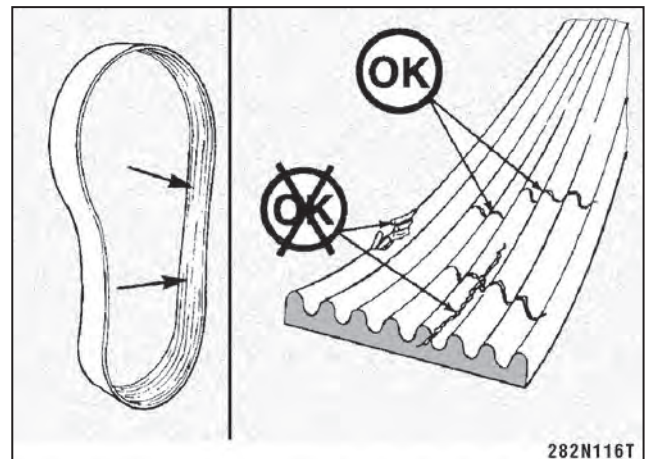

Tensioning the air-conditioning belt:

- Loosen the screws and move the compressor.
- Tighten the screws.

Replacing the air-conditioning belt:

- Loosen the screws and move the compressor.
- Take out the belt.
- Insert the new belt.
- Tighten the screws.
- Check the belt for correct tension.

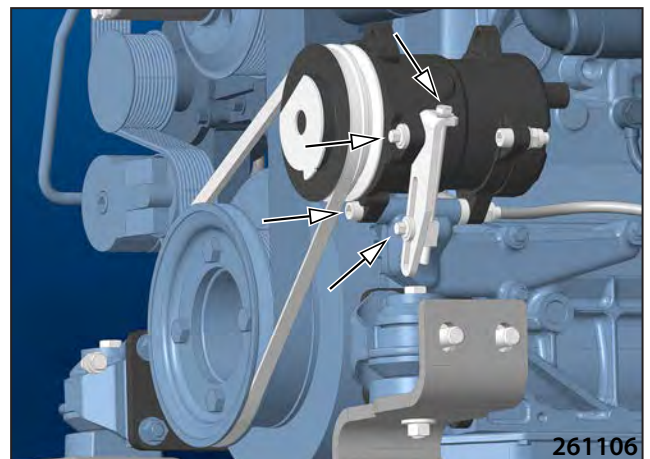

3.6.31 Engine belt inspection

Checking the engine belt for wear:

- Visually inspect the belt.
- Cracks perpendicular to the belt width are not considered to be a fault. If longitudinal cracks appear on the belt, or the belt edges are ragged, or some material parts are pulled off, then the belt must be replaced.

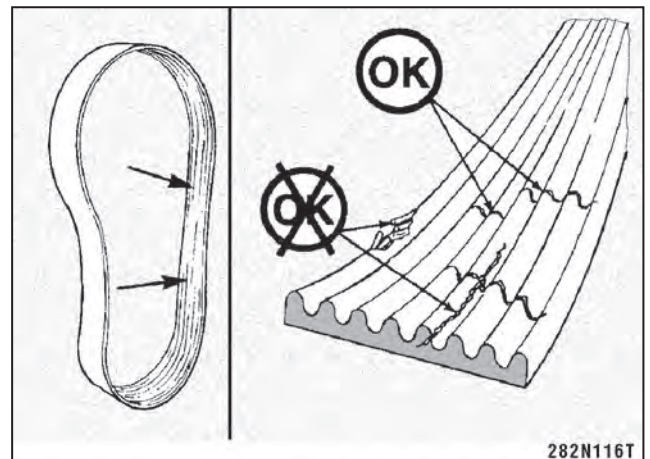
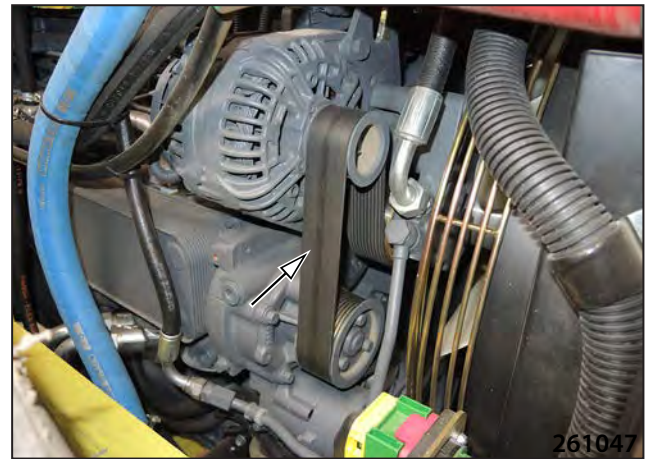

Replacing the engine belt:

- Loosen the screws and move the compressor.
- Take out the air-conditioning belt.
- Lift off the tension pulley of the belt using a square lever.
- Take out the engine belt.
- Insert the new belt.

Belt

Order number: 1320522



Change and tension the belt when the engine is not running!

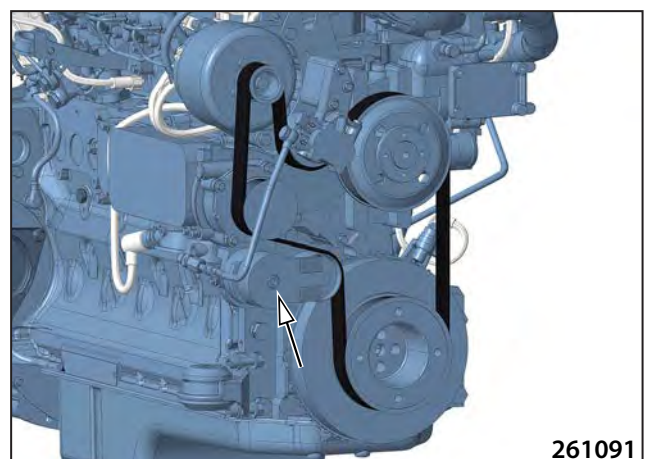
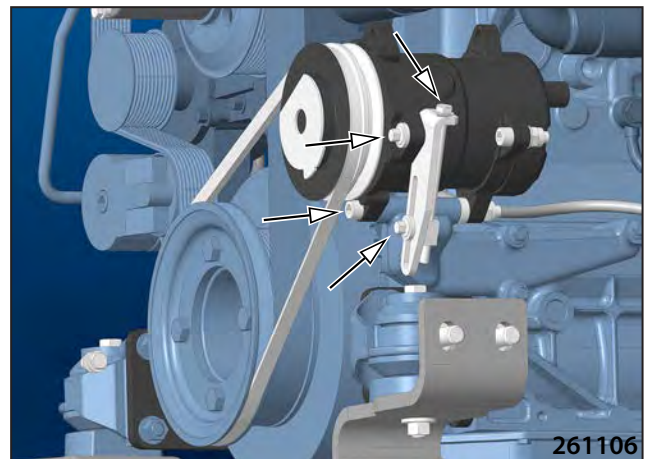

- Remove the cap.



- Remove the suction baskets.
- Clean the suction baskets.
- Remount the suction baskets.
- Inspect the interior of the tank.
- If the bottom is dirty, clean and rinse the tank carefully with the new oil.
- Remount the cap.
- Use the new sealing tape.

Sealing tape

Order number: 4-26380

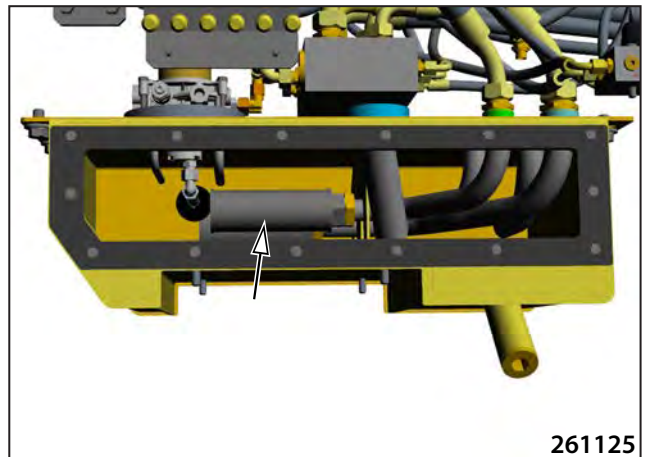

- Remount the connector of the level gauge.
- Remove the vent filter. Mount the new vent filter.

Vent filter

Order number: 1280287



3.6.44 Fuel system venting

- Vent the fuel system before the first start in the following cases:
 - replacement of the fine filter,
 - replacement of the fuel pump,
 - long-term shut-down of the machine,
 - when the tank is empty.

- Release the bleed screw on the fuel filter.
- Using a hand pump, add fuel into the fuel pre-cleaner until clean fuel starts to flow out of the fuel filter.
- Tighten the bleed screw on the fuel filter.



No smoking at work!
Do not perform bleeding when the engine is hot as escaping fuel can cause fire.



Collect the escaping fuel!

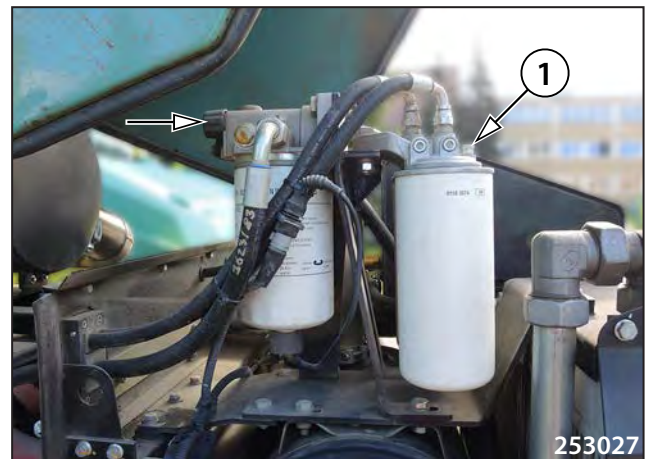

Error number BODAS/HEX	Error number SPN/DEC/Display	Name	Description	Saved	Only the active are displayed
8645	34373	Rough tachometer output	Error at the tachograph output, coarse vibration	Yes	No
8646	34374	Blade up valve output	Error at the blade lifting output.	Yes	No
8647	34375	Blade down valve output	Error at the blade lowering output.	Yes	No
8648	34376	Blade floating valve output	Error at the blade floating position output.	Yes	No

3.7.5 ACE errors

Error number BODAS/HEX	Error number SPN/DEC/Display	Name	Description	Saved	Only the active are displayed
8700	34560	ACE system fault	General ACE error. CM, parameters...	Yes	No
8701	34561	ACE compaction module	Error of communication with CM	Yes	No
8702	34562	ACE parameters	Incorrect ACE parameters	Yes	No

Error codes	SPN	FMI	Error description
752	107	0	Air filter differential pressure; air filter clogged.
753	523919	2	DPF burner air pump pressure sensor, plausibility error
755	523919	0	„DPF burner air pump pressure sensor, pressure above upper shutoff threshold“
758	523919	1	„DPF burner air pump pressure sensor, pressure below lower shutoff threshold“
761	523919	3	„DPF burner air pump pressure sensor, short circuit to battery or open load“
762	523919	4	DPF burner air pump pressure sensor, short circuit to ground
763	523920	2	Exhaustgaspressure upstream burner, plausibility error
765	523920	0	„Exhaustgaspressure upstream burner, pressure above upper shutoff threshold“
770	523920	3	„Exhaustgaspressure upstream burner, short circuit to battery or open load“
771	523920	4	Exhaustgaspressure upstream burner, short circuit to ground
772	102	2	Pressure downstream charge air cooler, plausibility error
774	102	1	„Pressure downstream charge air cooler, pressure below lower physical threshold“
776	102	3	„Pressure downstream charge air cooler, short circuit to battery or open load“
777	102	4	„Pressure downstream charge air cooler, short circuit to ground“
780	523699	3	„Boost pressure control; negative governor deviation below limit“
781	523699	4	„learning valu too high No detail informationen!“
785	523889	3	„over teperature of device driver of pressure control valve No detail informationen!“
791	411	0	„signal range check low error of pressure control valve AD-channel delta pressure across venturi in EGR line above physical high limit“
793	411	0	„Plausibility Check fault for deviation of desired and actual EGR-mass flow, where the latter is calculated out of EGR Delta Pressure Sensor“
795	411	3	„Sensor error differential pressure Venturiunit (EGR), signal range check low.“
796	411	4	„Sensor error differential pressure Venturiunit (EGR), signal range check high.“
805	524025	14	„Particulate filter regeneration. Regeneration after time X is not successful (The error occurs when the regeneration times (3x) over the max. has been aborted allowed recovery time).“
806	524058	2	Particulate filter; regeneration not succesful
807	3253	2	Differential pressure DPF, plausibility error
809	3251	0	Differential pressure DPF maximum value is exceeded
810	3251	0	„Differential pressure sensor across DPF exceeds warning high limit“
812	3251	1	„Differential pressure DPF, pressure below lower shutoff threshold.“
813	3251	1	„Differential pressure DPF, pressure below lower warning threshold.“
814	3253	3	„Electrical error differential pressure B58 (DPF). (signal range check high)“
815	3253	4	„Electrical error differential pressure (DPF). signal range check low.“
825	523009	9	„The pressure relief valve (PRV) has reached the number of allowed activations.“
826	523470	2	„Pressure relief valve is forced to open, perform pressure increase.“
827	523470	2	„Pressure Relief Valve (PRV) forced to open. Performed by pressure increase.“
828	523470	12	„Pressure Relief Valve (PRV) forced to open. Shutoff conditions.“

The texts are given only in the original language version or as a translation of the original into the English language version.

Error codes	SPN	FMI	Error description
1490	4376	5	SCR reverting valve; open load
1491	4376	12	SCR reverting valve; over temperature
1493	4376	4	SCR reverting valve; short circuit to ground
1505	524057	2	Fuel low pressure pump; error pressure build up
1523	2659	2	Exhaust Gas Recirculation AGS Sensor; signal not plausible
1524	2659	0	„Exhaust Gas Recirculation AGS Sensor; Sensed exhaust mass value above maximum physical value“
1525	2659	1	„Exhaust Gas Recirculation AGS Sensor; Sensed exhaust mass value below minimum physical value“
1526	2659	12	„Exhaust Gas Recirculation AGS Sensor; plausibility error, AGS sensor has not passed the burn off process“
1527	2659	2	„Exhaust Gas Recirculation AGS Sensor; Temperature of EGR mass not plausible“
1529	524070	2	„(Upstream NOx-Sensor) Diagnostic Fault Check for invalid upstream NOx value (Sensor self diagnostic DFC set by Deutz-SW) NOx-Sensor before SCR-Cat: Invalid upstream NOx value“
1530	524071	2	„(Downstream NOx-Sensor) Diagnostic Fault Check for invalid downstream lambda value (Sensor self diagnostic DFC set by Deutz-SW)“
1531	524072	2	„(Upstream NOx-Sensor) Diagnostic Fault Check for invalid upstream lambda value (Sensor self diagnostic DFC set by Deutz-SW)“
1532	524073	2	„(Downstream NOx-Sensor) Diagnostic Fault Check for invalid downstream NOx value (Sensor self diagnostic DFC set by Deutz-SW)“
1533	524074	9	„NOx sensor downstream SCR-CAT, sensor internally open load“
1534	524075	11	„NOx sensor downstream SCR-CAT, sensor internally short circuit“
1535	524076	9	NOx sensor upstream SCR-CAT, sensor internally open line
1536	524077	11	„NOx sensor upstream SCR-CAT, sensor internally short circuit“
1537	524078	9	„NOx sensor downstream SCR-CAT, lambda value above upper physical threshold“
1538	524079	9	„NOx sensor downstream SCR-CAT, lambda value below lower physical threshold“
1539	524080	9	„NOx sensor upstream SCR-CAT, lambda value above upper physical threshold“
1540	524081	9	„NOx sensor upstream SCR-CAT, lambda value below lower physical threshold“
1541	524082	9	„(Downstream NOx-Sensor) Diagnostic Fault Check for downstream NOx value over maximum limit (DFC set by Deutz-SW)“
1542	524083	9	„NOx-Sensor downstream SCR-CAT, NOx value below minimum value.“
1543	524084	9	„NOx-Sensor upstream SCR-CAT, NOx value above maximum value.“
1544	524085	9	„NOx sensor upstream SCR-CAT, NOx value below lower physical threshold“
1545	524149	2	„Plausibility error between pressure downstream turbine (PTrbnDs) and ambient air pressure (EnvP)“
1555	524063	5	„Relay Urea backflow line heater: broken wiring detected (open load) in-line engine: SCR-backflow line (K29) V-engine: Master: SCR-suction / backflow line (K32.1) Slave: SCR-suction / backflow line (K32.2)“
1556	524063	5	SCR main relay not connected
1557	524063	5	SCR heater pressureline; open load
1558	524063	3	SCR heater mainrelay; short circuit to battery

The texts are given only in the original language version or as a translation of the original into the English language version.

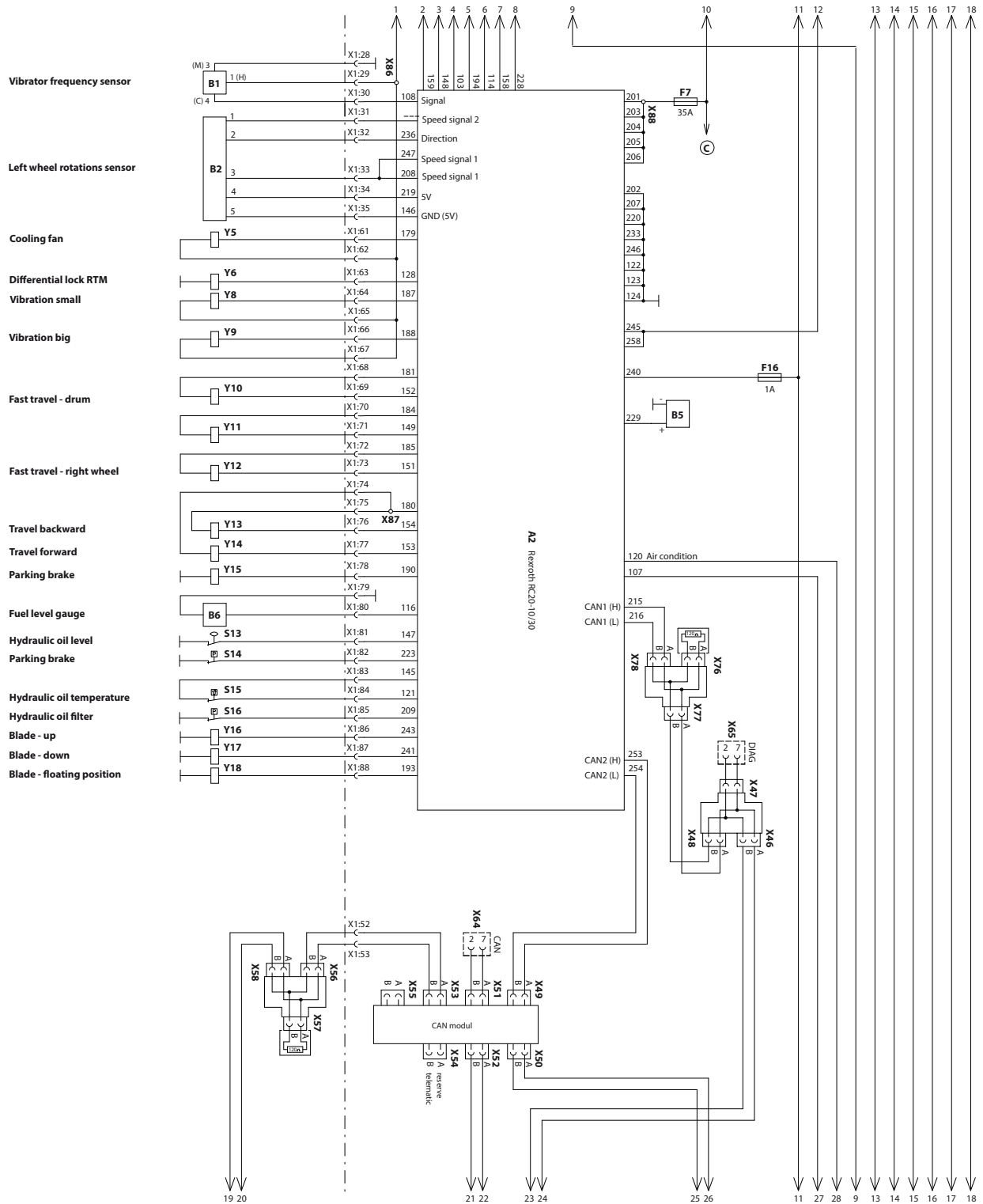

CLICK HERE TO **DOWNLOAD** THE COMPLETE MANUAL

- Thank you very much for reading the preview of the manual.
- You can download the complete manual from: www.heydownloads.com by clicking the link below



- Please note: If there is no response to CLICKING the link, please download this PDF first and then click on it.

CLICK HERE TO **DOWNLOAD** THE COMPLETE MANUAL