

ARS 200

SINGLE DRUM ROLLER

DEUTZ TCD6.1 L6

EU Stage V / U.S. EPA Tier 4f

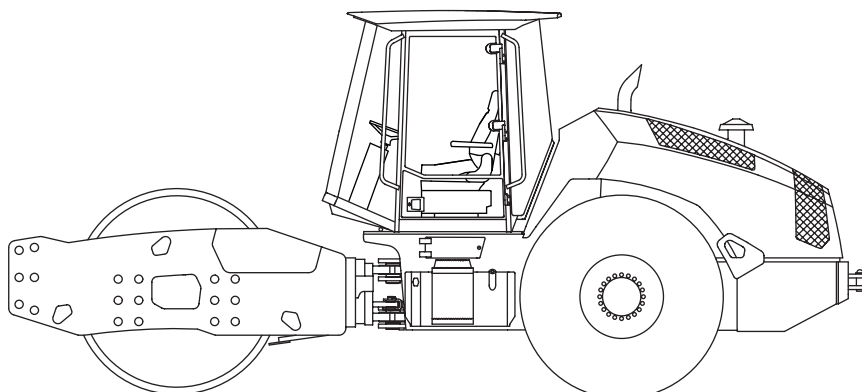

OPERATING MANUAL

EDITION 07/2022 EN
Product Identification Number 3047085 -

AMMANN

CLICK HERE TO **DOWNLOAD** THE COMPLETE MANUAL

- Thank you very much for reading the preview of the manual.
- You can download the complete manual from: www.heydownloads.com by clicking the link below



- Please note: If there is no response to CLICKING the link, please download this PDF first and then click on it.

CLICK HERE TO **DOWNLOAD** THE COMPLETE MANUAL

Every 250 hours of operation	154
3.6.15 Engine cooling circuit inspection	154
3.6.16 Air filter sensor check	156
3.6.17 Machine lubrication.....	158
3.6.18 Vibrator oil check	162
3.6.19 Travel gearbox oil check.....	163
3.6.20 Checking pad-foot segments	165
3.6.21 Seat switch check.....	165
Every 500 hours of operation, but at least once a year	166
3.6.22 Engine oil change	166
3.6.23 Engine coolant level check.....	169
3.6.24 (Air-conditioning) belt check.....	170
3.6.25 Fuel filter replacement.....	171
3.6.26 Air filter element replacement.....	173
3.6.27 Checking wheel screws for tightening.....	176
3.6.28 Cleaning the cab ventilation filter	176
3.6.29 Wiring inspection.....	176
Every 1000 hours of operation	177
3.6.30 DEF (AdBlue) filter replacement	177
3.6.31 Intake manifold inspection	180
3.6.32 Battery inspection	181
3.6.33 Engine belt inspection	183
3.6.34 Engine belt tensioner check	184
3.6.35 Travel gearbox oil change.....	184
3.6.36 Shock-absorbing system inspection.....	186
3.6.37 Engine inspection	188
3.6.38 Engine and machine diagnostics.....	188
Every 2000 hours of operation	189
3.6.39 Vibrator oil change	189
3.6.40 Cleaning and checking the air conditioning system	190
3.6.41 Hydraulic oil change and filter replacement.....	191
3.6.42 Cleaning the suction filter of the cab and bonnet lifting and lowering unit	197
3.6.43 Valve clearance check, adjustment	198
3.6.44 Vent plug replacement	198
Every 6000 hours of operation	199
3.6.45 Engine coolant change.....	199
Maintenance - As Needed	202
3.6.46 Cooler cleaning.....	202
3.6.47 Fuel system venting	203
3.6.48 Machine cleaning.....	204
3.6.49 Scraper adjustment.....	204
3.6.50 DPF clogging regeneration (Diesel Particulate Filter)	205
3.6.51 Charging of the battery	206
3.6.52 Checking screw connections for tightening.....	207

	ARS 200			
	EU Stage V / U.S. EPA Tier 4f			
	D	HX	PD	HXPD
Optional equipment				
Air-conditioning				
Preparation for radio (box, 2 loudspeakers, antenna)				
Radio				
Additional padfoot segments (recommended with ATC and tractor tyre)				
Tractor tyre				
Vulcolan scrapers (only for smooth drum)				
ACE Force				
GPS for ACE system				
Telematic				
Night operation lighting				
Road operation lighting				
Beacon				
Back signal horn				
Fire extinguisher				
Engine pre-filter				
Special paint schema				
Biologically degradable hydraulic oil				
Set of filters, 500 h				
Set of filters, 1000 h				
Set of filters, 2000 h				
Certificate of Origin				
Additional documentation				
Topcon				

2.1.5 Safety notices and signs applied on the machine

1. Pinch points



2941bz

Maintain a safe distance from the machine; there is a danger of squeezing by the machine between the front and rear frames.

2. Risk of burns



2586bz

There is a risk of burns. Do not touch hot parts of the machine unless you make sure that they are sufficiently cold.

3. Risk of injury



2409bz

There is a risk of injury. Do not touch rotating parts while the engine is running.

4. Risk of scalding



3227bz

There is a risk of scalding. Do not open the cap until the fluid cools down below 50 °C (122 °F).

5. Keep calm and adjust



2584bz

Turn off the engine and remove the key from the ignition box before maintenance or repairs are performed.

6. Read the operation manual



2702bz

Familiarize yourself with the operation and maintenance of the machine according to the operation manual!

When disposing the machine following its service life, the user is obliged to follow national waste and environmental regulations and acts. In the above cases, we recommend you to always contact:

- Specialized companies with a respective authorization for these operations.
- The machine manufacturer or accredited contracting service organizations authorized by the manufacturer.



The manufacturer shall not be responsible for damage to the health of users or environmental damage caused by the non-compliance with the above mentioned rules.

Operator seat (19)

Seat adjustment:

1. Head rest
2. Backrest position
3. Seat shifting
4. Seat angle
5. Seat springing stiffness according to the weight indicator



Adjust the seat before driving the machine!

The driver must be fastened with the seat belt while driving!

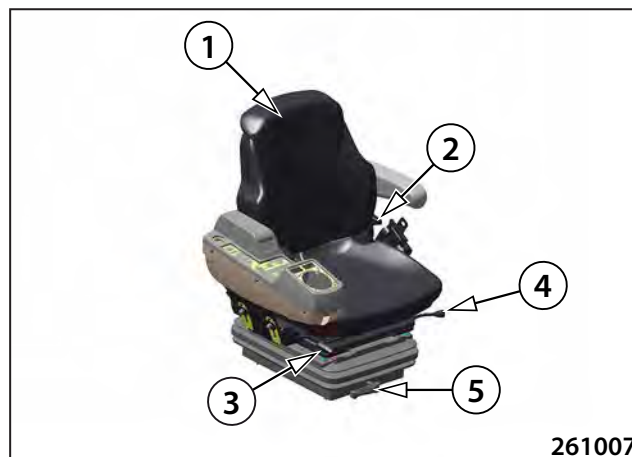
**Seat switch:**

The seat switch is located in the seat cushion.

If the driver does not sit on the seat, one of the following limitations occurs – locking the machine moving-off, stopping the machine or turning off the engine.

The machine reaction differs depending on the position of the travel control, the seat switch activation (if the operator sits or does not sit on the seat) and the time during which the seat switch is disabled.

Travel control in the parking brake position

- the driver can leave the seat when the engine is running provided that no one moves around the machine and the machine is properly secured against misuse or theft.
- if the driver does not sit on the seat and the travel control is tilted out of the parking brake position, the engine will stop working immediately.
- if servicing or maintenance is performed on the machine, the driver must enable the service switch.

Heating control

It is used for turning on the cab heating.

The liquid volume flowing to the heater can be continuously regulated from the MIN position (valve closed) to the MAX position (valve fully open).



Adjust the heating valve and recirculation valve before driving!



Air filter of cab ventilation

It includes a replaceable filter element, on which impurities from the sucked air are caught.



Heating outlet

The adjustment and angle of the flaps allows you to change the quantity and direction of the air flow.



Recirculation valve

The change-over switch is used for opening the recirculation valve.

Closed – internal air circulation

Open – outside air intake





Transport mode button

It is used for enabling and disabling the transport mode. The activation and deactivation is done by entering PIN.

The active transport mode is indicated by the icon on the display.

The transport mode of the machine is set by the manufacturer and is used for the shipment and transportation of the machine to a customer.

Only the following functions are enabled in the transport mode:

- Differential lock ON
- Speed gear 0 ON – speed 0–3 km/h (0–1.9 MPH)

Procedure:

- Press the transport mode button (the screen will be displayed to enter PIN).
- Enter PIN.
- Confirm by pressing the OK button for 4 seconds (audible signal will be heard).



To enable and disable the ignition lock or transport mode, use the same PIN code.

For the PIN code, see the PIN card in the documentation set. There are two PIN cards supplied with the machine.

If you lose the PIN card, you can contact your dealer and get your correct PIN code for your machine.

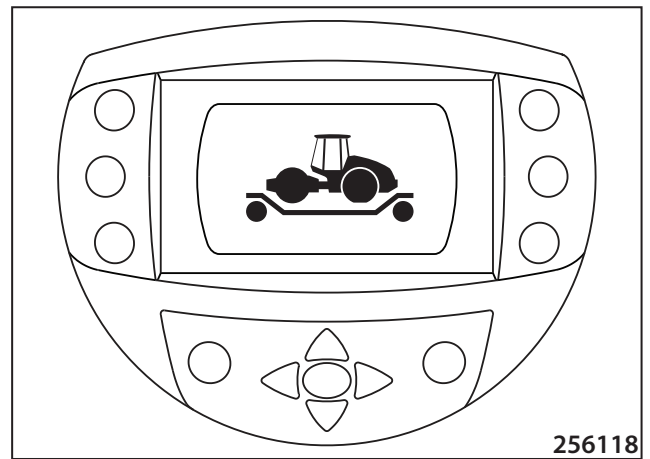

256118

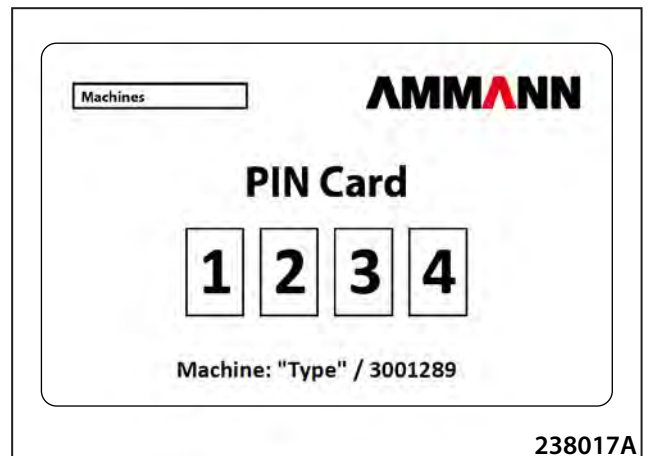

238017A



Brake test button

It is used for checking the machine brakes for correct operation (the operator is prompted to check the brakes every 24 hours).

After you press the brake test button, a confirmation dialogue will appear.

Press the middle button (A) to confirm the start of the brake test.

Press the lower button (A) to cancel the start of the brake test.



Perform the brake test according to Chapter 3.6.13.

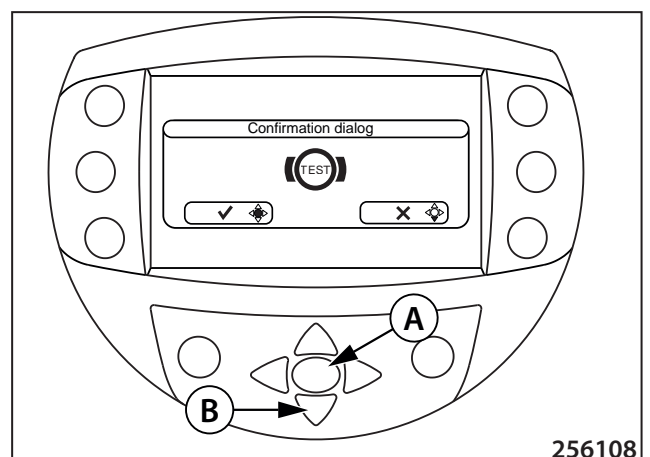

256108

When the hydraulic oil has warmed up to a temperature higher than 10 °C, a warning will be displayed, accompanied by an acoustic signal, if the travel control (3) is in forward/reverse (F/R).

The warning disappears when the travel control (3) is moved to neutral (N) or parking brake (P).

This deactivates the warm-up mode.

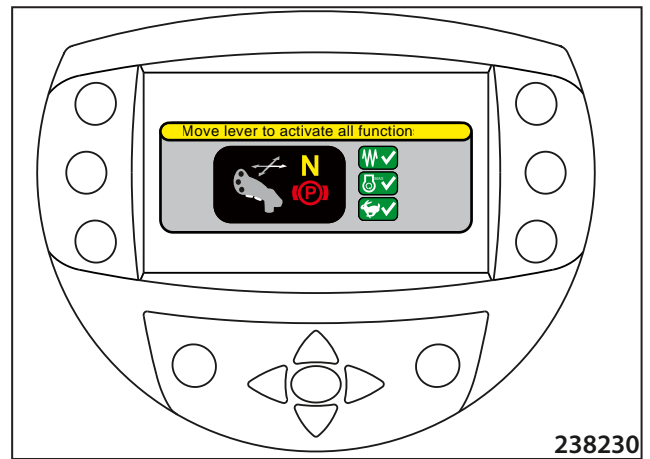

2.7.3 Stopping the machine and engine

- Press the button (6) on the travel control (3) to switch off the vibration.
- Stop the machine by changing the travel control (3) to the neutral position (N).
- Brake the machine by changing the travel control (3) to the brake position (P).
- Switch over the key in the ignition box (18) to the position "0" and close the cap of the ignition box.

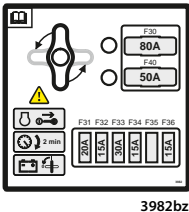

Switch off the battery disconnect no sooner than 120 seconds after removing the key from the ignition switch.

The time limit must be observed to pump DEF (AdBlue) back into the tank and store the ECM engine data.

By failing to adhere to this time limit you take the risk of damaging the machine, for which the manufacturer bears no responsibility.



Do not stop the hot engine instantly but let it idle for 3 minutes. The engine and the turbocharger will cool down slowly and evenly!

The travel control (3) must be always in the brake position (P)!

Turn off the battery disconnect while parking the machine!

2.7.4 Machine emergency stop



Use in case of a failure when it is impossible to stop the engine with the key in the ignition box or by changing the travel control (3) to the brake position (P)!

Turning on:

- After pressing the emergency brake button (11), the machine is braked and the engine stops.
- The parking brake indicator lamp lights up on the display (2).

Turning off:

- Turn the emergency brake button (11) in the direction of arrows.
- The parking brake indicator lamp keeps lighting on the display.
- Move the travel control (3) to the position (P); you can restart the engine in this position.

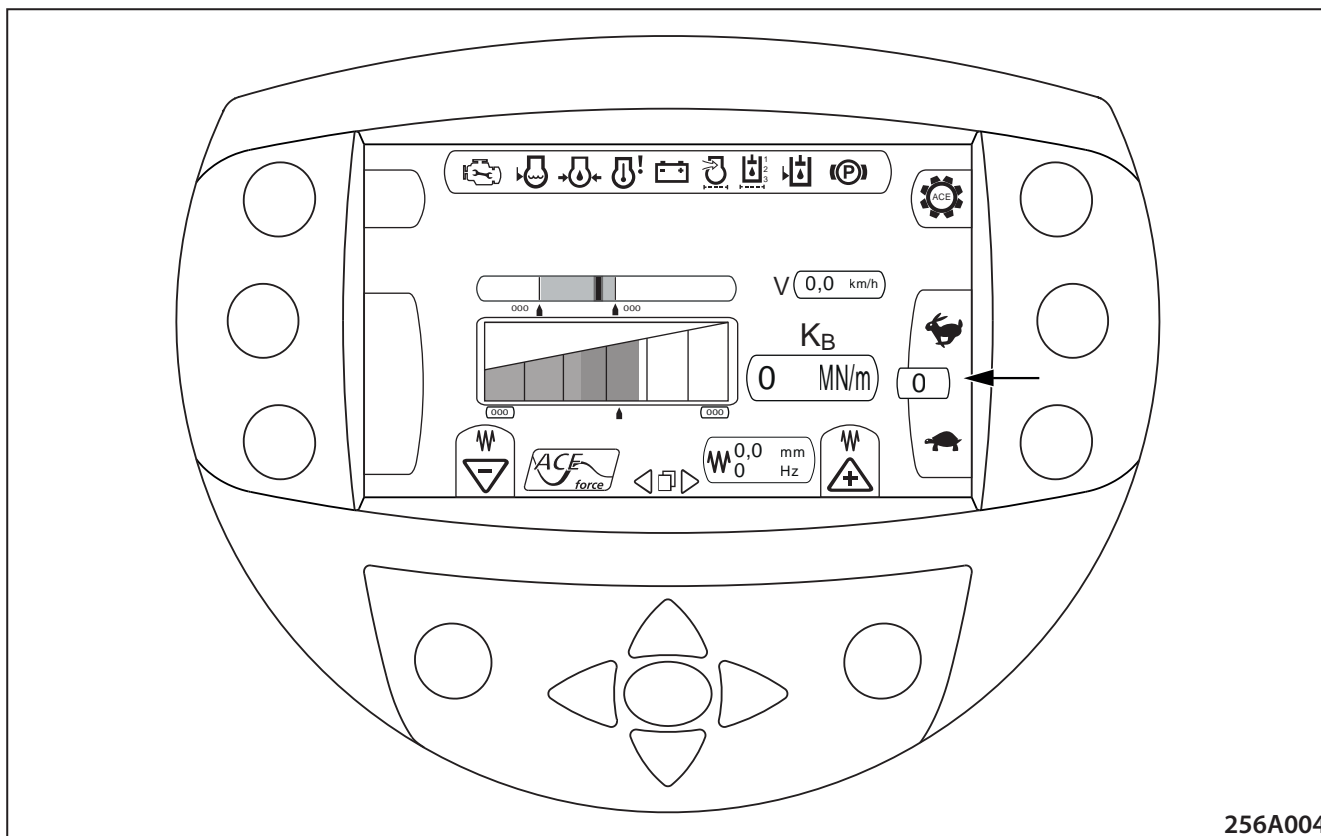

256A004

2.7.7.3 Speed selection

ACE Force system is activated via start of the vibration.

ACE Force functions (Kb graph bar, speed recommendation function, frequency/amplitude info bar, will be active only in working speed selection (speed 1–4).

Note:

If transportation mode or loading mode speed will be selected, ACE functions/bars are inactive.

ACE Force functions are active in working speed range according to the table below.

Machine	Drive	Working speed range
ARS 200	D	1 - 4
	HX	1 - 4

2.7.8 Scraper adjustment

Scrapers for smooth drum

- Loosen the screws (1) and move the holders (2) to the drum at the distance of 25 mm (0.98 in) between the scraper and the drum.
- Tightening torque 314 Nm (231.6 lb ft).

Scraper

Order number: 4-12038A



If it is possible to shift the scrapers in oval holes of the holders (2) after the scraper (3) is used up, remove the scraper (3) and shift it by one hole towards the drum.

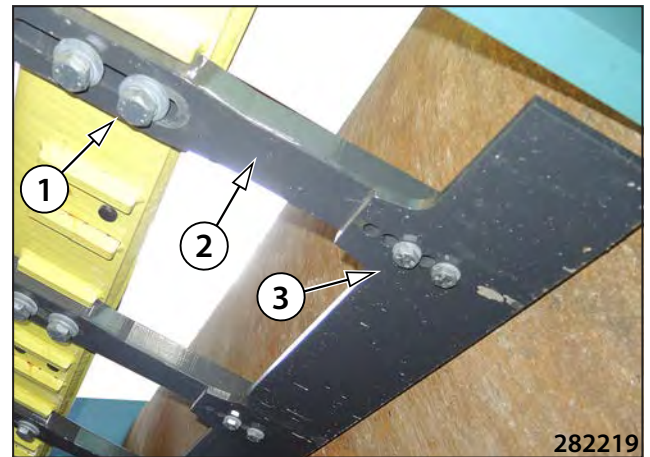

Scrapers for pad-foot drum

- Loosen the screws (1) and move the individual scrapers (2) to the drum at the distance of 35 mm (1.38 in).
- Tightening torque 314 Nm (231.6 lb ft).

Scraper

Order number: 4-21342



If a small gap is adjusted between the scraper and the drum, the scraper can get in contact with the drum when the machine turns.

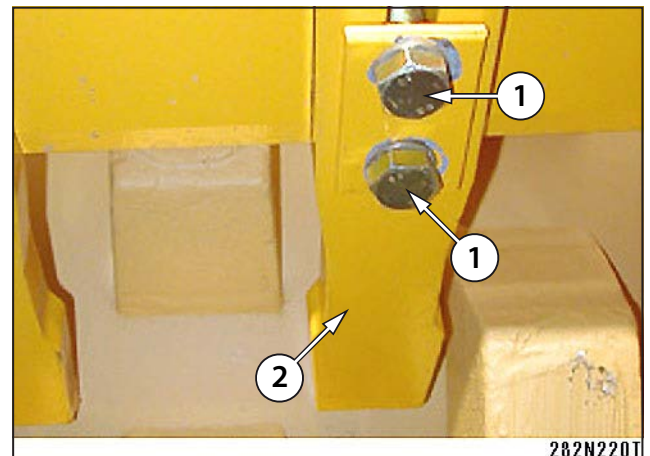

Polytan contact scrapers (optional equipment)

- Loosen the screws (1) and move the scraper (2) to the drum.

Scraper

Order number: 4-28168

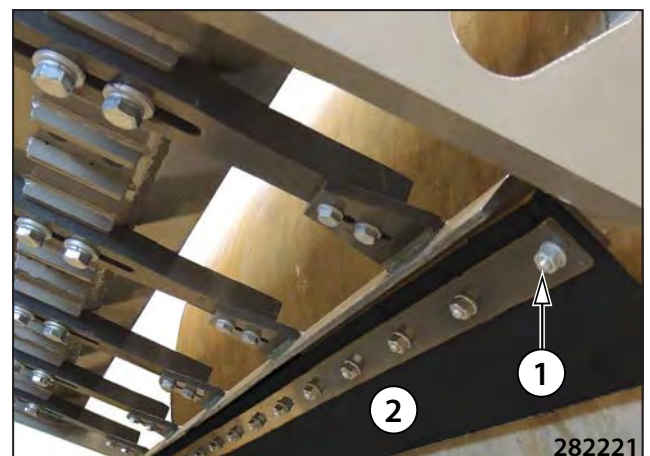

Release the brakes:



Before releasing the brake, secure the machine with wooden scotch blocks against movement!

- Remove the lever (1).
- Adjust the washer to the position B.

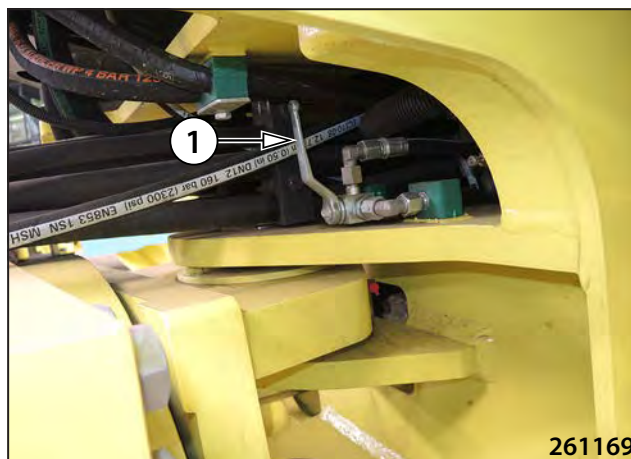

261169

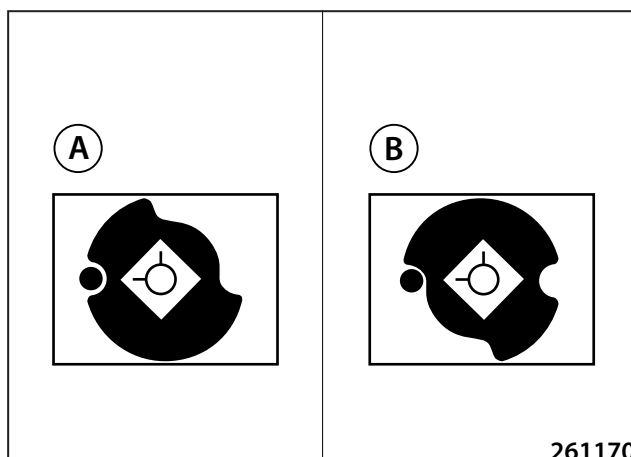

261170

- Remount the lever (1).
- Adjust the lever to the position 2.

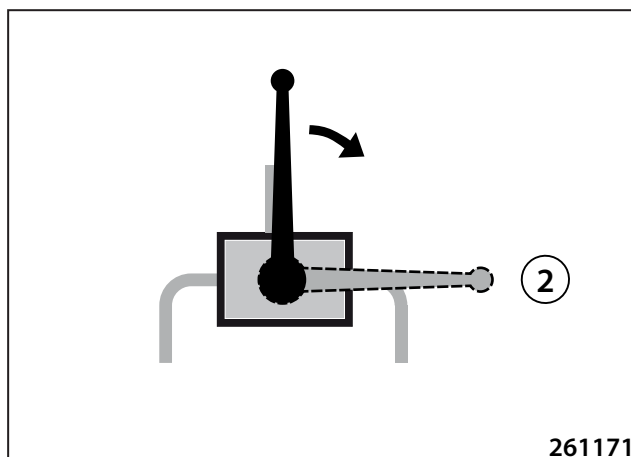

261171

- Insert the control lever into the pump and pressurize the circuit by 9 full strokes (one stroke = movement of the lever to the left and right).
- Now the machine brake is released, and the machine can be towed.



261161

CLICK HERE TO **DOWNLOAD** THE COMPLETE MANUAL

- Thank you very much for reading the preview of the manual.
- You can download the complete manual from: www.heydownloads.com by clicking the link below



- Please note: If there is no response to CLICKING the link, please download this PDF first and then click on it.

CLICK HERE TO **DOWNLOAD** THE COMPLETE MANUAL

3.2.1 Engine oil



2412

The engine oil is specified according to the performance and viscosity classification.

Performance classification

Due to the emission requirements Tier 4 final, the engine manufacturer requires so that only such oils are used that are certified by Deutz company.

Permissible oils according to DEUTZ QUALITY CONTROL (DQC):

DQC III LA

DQC IV LA

For a current list of oils corresponding the classification see the webpage of the engine manufacturer Deutz (www.deutz.com).



If a failure occurs due to the use of an incorrect oil, the guarantee shall be cancelled.

Viscosity classification

To determine the viscosity class SAE (Society of Automotive Engineers), the ambient temperature and type of operation where the machine is used are decisive.

Note

Exceeding the lower temperature limit does not result in damage to the engine; it can only cause some starting difficulties.

It is convenient to use universal multi-range oils to avoid oil changes due to the ambient temperature.



Exceeding the upper temperature limit can result in decreasing lubricating abilities of the oil and cause a high oil degradation.

Reduce the oil change interval by half if there is at least one of the following:

- ambient temperature is permanently below -10 °C;
- oil temperature during operation of the machine is below 60 °C.

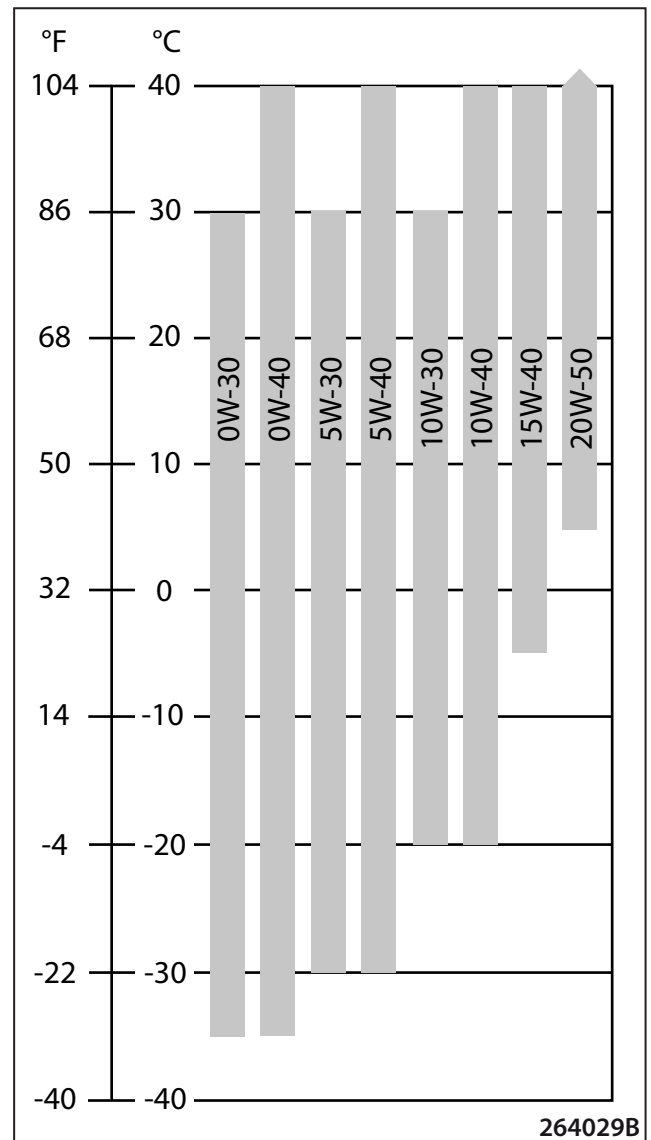

Every 20 hours of operation (daily)

3.6.1 Engine oil level check

- Wait about 5 minutes until the oil runs down to the engine sump.
- Take out the oil dipstick (1), wipe it, insert fully back and take it out again to read out the oil level.

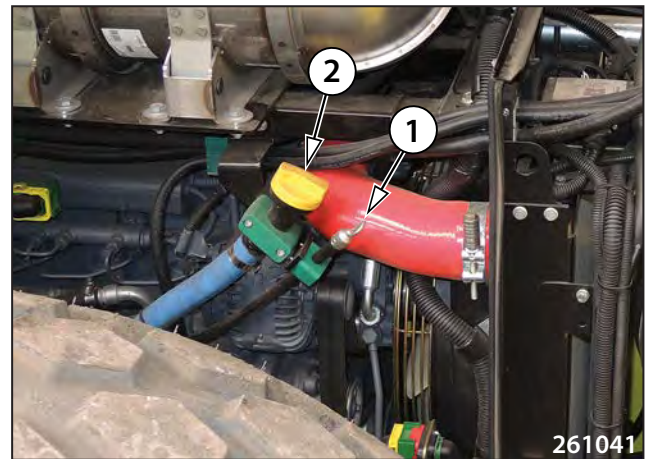

- Keep the level within the range of gauge marks imprinted in the dipstick. The lower mark MIN shows the lowest possible oil level, the upper mark MAX the highest one..
- After removing the filler plug (2), refill the oil through the oil filler. Wait about 1 min. until the level is stable and check again.
- Refill the identical type of oil. Use oils according to chapter 3.2.1.
- Check the engine for leakage, repair possible causes.
- Check the engine for damaged and missing parts and for changes in appearance.



Do not use the engine if the oil level in the engine is not correct.

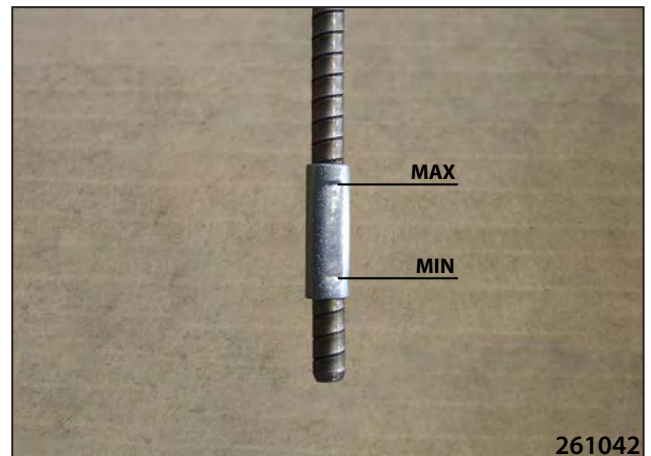

3.6.12 DEF (AdBlue) level check

- Check the DEF (AdBlue) volume on the display and refill if necessary.

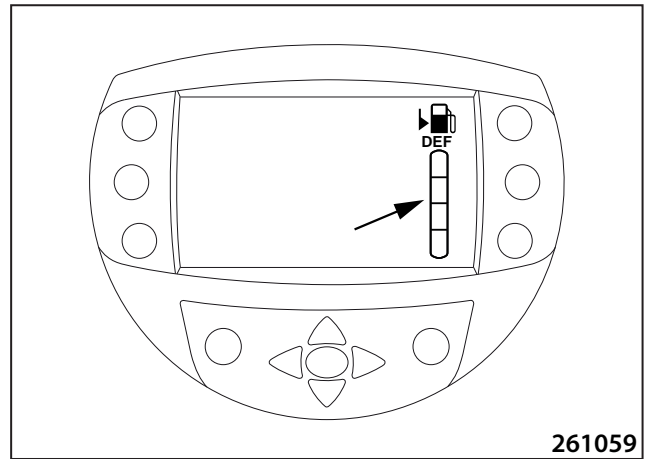

261059

- Remove the tank cap.
- Refill DEF (AdBlue).

Note

When the DEF (AdBlue) level indicator lights up (< 15 %), refill 18 l (4.8 gal US) to the maximum level of the tank.



Provide adequate ventilation.

In case of insufficient ventilation, wear suitable respiratory equipment. Recommended: organic fumes filter (A type), ammonia filter (K type).

Wear suitable chemical resisting, impervious gloves.

Wear goggles intended for splash water protection.

Avoid contact with skin. Wear suitable protective clothing.



261060



Refill according to the prescribed specification according to chapter 3.2.6.

Add anti-freeze agent according to chapter 3.3.

Fill 10 l (2.64 gal US) of DEF (AdBlue) at least or fill up the tank.

Using other fluids than prescribed will cause irreparable damage of the SCR system.

If incorrect fluid is used, never switch the ignition on or start the engine!

DEF (AdBlue) concentration is monitored by the control unit. When the quality requirements are breached, engine power is reduced.

Refill with the engine off!

Maintain cleanliness. Prevent contamination of the system with surrounding dust.

- After it is covered, the indicator lamp for the air filter clogging must light up.

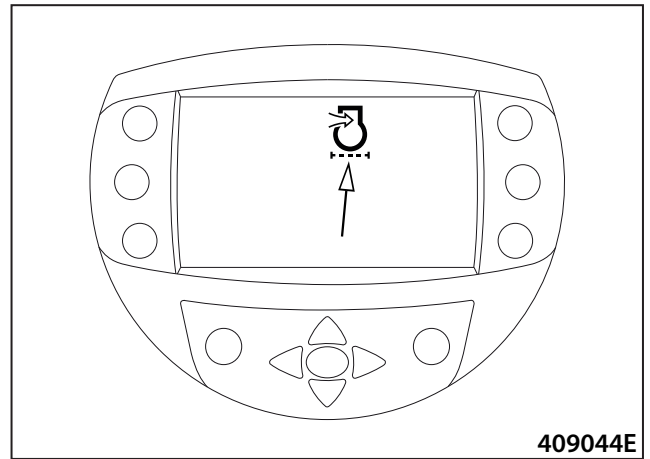

- Unless indicator lamp goes ON, check the vacuum switch, contacts and feeder cables.

Sensor

Order number: 4-5358520063



- Take the new filter.
- Fill the filter with clean engine oil.

Engine oil filter

Order number: 1320509



396248

- Lubricate the gasket with oil.

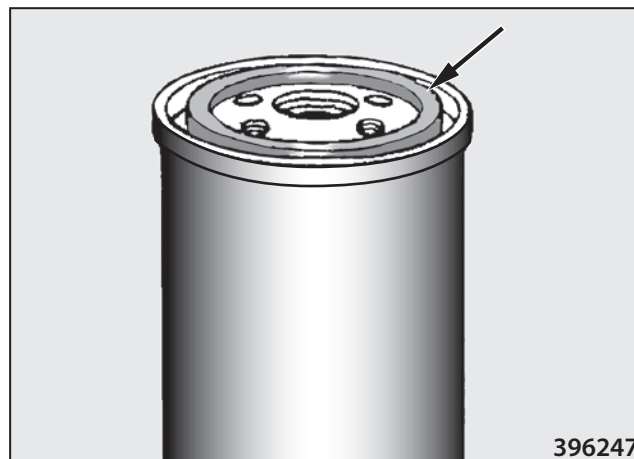

396247

- Tighten the filter by 3/4 to 1 revolution after the filter makes contact with the filter head.
- Tightening torque 15–17 Nm (11–12.5 lb ft).



Do NOT overtighten the filter, its thread and gasket may get damaged.

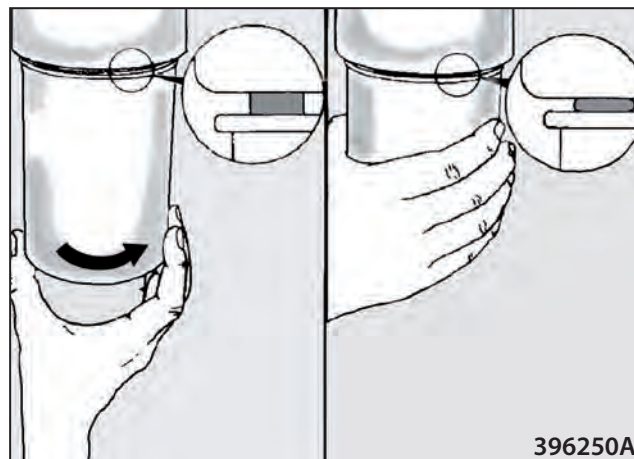

396250A

Every 1000 hours of operation

3.6.30 DEF (AdBlue) filter replacement

The set of filters (1000 h) can be ordered under the order number 4-760275. For the list of all spare parts, see the table in the end of this publication.



Provide adequate ventilation.

In case of insufficient ventilation, wear suitable respiratory equipment. Recommended: organic fumes filter (A type), ammonia filter (K type).

Wear suitable chemical resisting, impervious gloves.

Wear goggles intended for splash water protection.

Avoid contact with skin. Wear suitable protective clothing.

Keep clean.

- Turn off the engine.
- Place a vessel under the filter.
- Remove the cap.



- Pull out the levelling item.



Rubber-metals of the engine 6x.

Rubber mount

Order number: 1399170

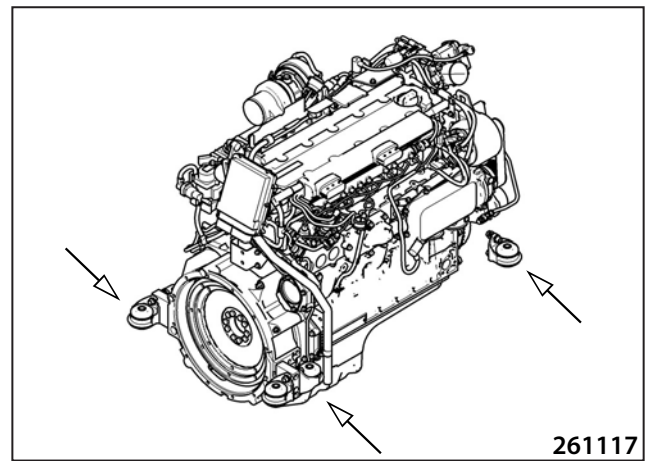

3.6.42 Cleaning the suction filter of the cab and bonnet lifting and lowering unit



Clean while changing the hydraulic oil.

- Remove the connector of the level gauge.
- Remove the cap of the hydraulic tank.



- Remove the filter.
- Clean the filter.
- Remount the filter.



Stop the oil soaking into the ground!

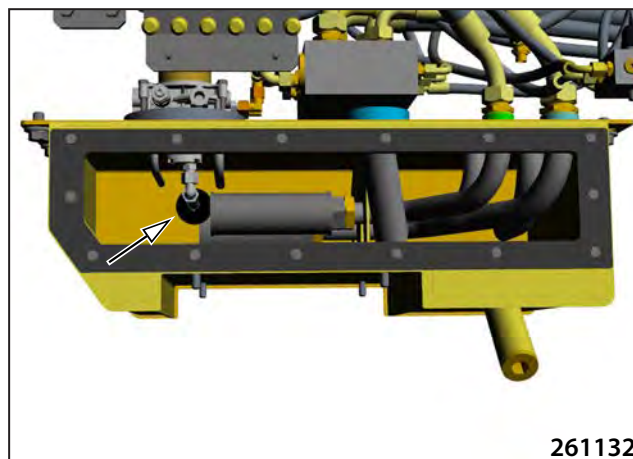

3.6.52 Checking screw connections for tightening

- Check regularly whether the screwed joints are not loosened.
- Use the torque spanner for tightening.

Thread	TORQUE				Thread	TORQUE			
	For 8,8 (8G) bolts		For 10,9 (10K) bolts			For 8,8 (8G) bolts		For 10,9 (10K) bolts	
	Nm	lb ft	Nm	lb ft		Nm	lb ft	Nm	lb ft
M6	10	7,4	14	10,3	M18x1,5	220	162,2	312	230,1
M8	24	25,0	34	25,0	M20	390	287,6	550	405,6
M8x1	19	14,0	27	19,9	M20x1,5	312	230,1	440	324,5
M10	48	35,4	67	49,4	M22	530	390,9	745	549,4
M10x1,25	38	28,0	54	39,8	M22x1,5	425	313,4	590	435,1
M12	83	61,2	117	86,2	M24	675	497,8	950	700,6
M12x1,25	66	48,7	94	69,3	M24x2	540	398,2	760	560,5
M14	132	97,3	185	136,4	M27	995	733,8	1400	1032,5
M14x1,5	106	78,2	148	109,1	M27x2	795	586,3	1120	826,0
M16	200	147,5	285	210,2	M30	1350	995,7	1900	1401,3
M16x1,5	160	118,0	228	168,1	M30x2	1080	796,5	1520	1121,0
M18	275	202,8	390	287,6					

The values given in the Table are torques at dry thread (at coefficient of friction = 0,14). These values DO NOT apply to greased thread.

Chart for torques of cap nuts with "O" sealing ring - hoses

Spanner size	Thread	Pipe	Torques of cap nuts with "O" ring - hoses					
			Nm			lb ft		
			Nominal	Min	Max	Nominal	Min	Max
14	12x1,5	6	20	15	25	15	11	18
17	14x1,5	8	38	30	45	28	22	33
19	16x1,5	8	45	38	52	33	28	38
		10						
22	18x1,5	10	51	43	58	38	32	43
		12						
24	20x1,5	12	58	50	65	43	37	48
27	22x1,5	14	74	60	88	55	44	65
		15						
30	24x1,5	16	74	60	88	55	44	65
32	26x1,5	18	105	85	125	77	63	92
36	30x2	20	135	115	155	100	85	114
		22						
41	36x2	25	166	140	192	122	103	142
46		28						
50	42x2	30	240	210	270	177	155	199
50	52x2	35	330	280	380	243	207	280
		38						
		42						

3.7.7 Engine errors

Error codes	SPN	FMI	Error description
8	132	1	The air mass flow AFS_dm is greater than or equal to AFS_PhysRng.Min_C. Physical range check is low for air mass flow sensor.
9	172	2	Air inlet filter temperature, plausibility error.
26	523891	14	When AirHt_ctDefSRCLoOn_mp is lower than AirHt_ctMaxDef_C. DFC to SRC Low error when heater is on.
28	523953	2	Healing takes place if the condition for error detection is not present. Air temprature monitoring plausibility check array.
30	523955	2	Healing takes place if the condition for error detection is not present. Air temperature monitoring plausibility check array.
36	523923	3	
37	523924	3	Short circuit to battery error of actuator relay 2.
38	523925	3	Short circuit to battery of actuator relay 3.
40	523927	3	Short circuit to battery of actuator relay 6.
41	523923	4	Short circuit to ground error. Detailinformation not available.
42	523924	4	Short circuit to ground of actuator relay 2.
43	523925	4	Short circuit to ground of actuator relay 3.
44	523926	4	Short circuit to ground of actuator relay 4.
45	168	3	Sensor battery voltage error; signal range check is high.
46	168	4	Sensor battery voltage error; signal range check is low.
47	168	2	High battery voltage; warning threshold is exceeded.
48	168	2	High battery voltage; Shot off threshold exceeded.
55	523910	14	Air pump doesn ´t achieve air mass flow setpoint. Burner Control - burner air pump
56	524013	7	Burner does not start after several trials (burner flame lost detection). Burner flame unintentional deleted.
57	524020	14	Burner Control: Power reduction due to low lambda. Engine power: Not enough oxygen for regeneration.
58	523911	0	Burner dosing valve (DV2); Overcurrent at the end of the injection phase.
59	523911	12	Burner dosing valve (DV2); Powerstage over temperature.
60	523911	3	Burner dosing valve (DV2); Short circuit to battery.
62	523911	4	Burner dosing valve (DV2); Short circuit to ground.
63	523911	11	Burner dosing valve (DV2); Short circuit high side powerstage.
64	523912	2	Burner dosing valve (DV2) downstream pressure sensor; plausibility error.
66	523912	0	Physical range check high for burner dosing valve (DV2) downstream pressure; Shut off regeneration.
69	523912	1	Physical range check low for burner dosing valve (DV2) downstream pressure; Shut off regeneration. When burner injector is actuated, the measured pressure does not rise above 1250mbar abs (expected: about 2400mbar).

The texts are given only in the original language version or as a translation of the original into the English language version.

Error codes	SPN	FMI	Error description
892	4345	11	Sensor backflow line pressure (SCR); plausibility error
893	4343	11	SCR Monitoring; Pressure stabilisation error, general pressure check error (SCR)
894	4374	13	Pressure stabilisation error dosing valve (SCR)
897	523632	16	Pump pressure SCR metering unit too high.
898	523632	18	Pump pressure SCR metering unit too low
899	523632	0	Pressure overload of SCR-System.
900	523632	1	Pressure build-up error SCR-System.
903	4365	0	DEF tank temperature too high.
905	3241	0	Sensor SCR catalyst upstream temperature too high; plausibility error.
908	3361	7	DEF dosing valve blocked (SCR)
914	523720	2	DEF supply module heater temperature; plausibility error (normal condition).
915	523720	2	Sensor DEF supply module heater temperature; plausibility error (cold start condition)
916	523721	2	Sensor DEF supply module temperature; plausibility error (normal condition)
917	523721	2	Sensor DEF supply module temperature; plausibility error (cold start condition)
918	523981	11	SCR plausibility, OBD and diagnosis; Stuck in range check of DEF tank temperature sensor DEF-tank without heating function (heating phase)
919	523330	14	Immobilizer status; fuel blocked
920	523330	14	DFC to block the fuel by Sia No detail informationen!
921	523330	14	DFC to indicate that TEN-code or UC-code received if ECU is learned. No detail informationen!
922	523330	14	DFC to indicate that no code is received via CAN. No detail informationen!
923	523330	14	DFC to indicate that wrong code is received. No detail informationen!
925	523720	8	DEF supply module heater temperature; duty cycle in failure range.
926	523720	8	DEF supply module heater temperature; duty cycle in invalid range.
927	523721	11	Urea supply module temperature measurement not available.
928	523722	8	DEF supply module PWM signal; period outside valid range.
929	523722	8	Detect faulty PWM signal from Supply Modul.
930	523721	8	DEF supply module temperature; duty cycle in failure range.
931	523721	8	Urea supply module temperature; duty cycle in invalid range.
932	29	3	Handthrottle idle validation switch; short circuit to battery
935	91	3	Sensor error accelerator pedal. Signal range check high.
937	29	4	Handthrottle; short circuit to ground
940	91	4	Sensor error accelerator pedal. Signal is below the range.
942	523921	3	Sensor error burner temperature; signal range check high
943	3532	3	ensor error DEF tank level; signal range check high
944	523921	4	Sensor error burner temperature; signal range check low

The texts are given only in the original language version or as a translation of the original into the English language version.

Error codes	SPN	FMI	Error description
1647	524063	12	DEF tank, time for defrosting too long
1654	1761	14	Urea Tank Signal to HMI for indicating the Urea Tank-Level (Urea tank volume ratio low threshold 1)
1655	1761	14	DEF tank, DEF level below first warning threshold
1656	1761	14	DEF tank, DEF level below second warning threshold
1658	524096	14	Control of the SCR system; If the start stop counter (EPA-Counter) exceeds the threshold SCRctl_ctEngStrtStopThresh_C. This counter will increment only once in each driving cycle in case of an SCR error. If the counter reaches the threshold, the DFC will be set to inhibit the engine start Engine will not be started, because of EPA-Counter
1659	524114	9	Timeout error of CAN-Transmit-Frame A1DOC
1660	524115	9	Timeout error of CAN-Transmit-Frame AT1S
1661	524116	9	Timeout error of CAN-Transmit-Frame SCR2
1662	524117	9	Timeout error of CAN-Transmit-Frame SCR3
1663	524097	9	Timeout error of CAN-Transmit-Frame DPFBrnAirPmpCtl
1664	524098	9	Timeout error of CAN-Transmit-Frame ComDPFBrnPT
1665	524099	9	Timeout error of CAN-Transmit-Frame ComDPFC1
1666	524100	9	Timeout error of CAN-Transmit-Frame ComDPFHisDat.
1667	524101	9	Timeout error of CAN-Transmit-Frame ComDPFTstMon
1668	524105	9	Timeout error of CAN-Transmit-Frame ComEGRMsFlw (EGR Steller)
1669	524108	9	Timeout error of CAN-Transmit-Frame ComEGRTVActr (EGR actuator)
1670	524110	9	Timeout error of CAN-Transmit-Frame ComETVActrTO.
1671	524112	9	Timeout ComIntake Throttle Valve Actr.
1672	524118	9	Timeout error of CAN-Receive-Frame ComRxCM1
1675	524103	9	Timeout error of CAN-Receive-Frame ComRxDPFBrnAirPmp
1676	524104	9	Timeout error of CAN-Receive-Frame ComRxDPFCtl.
1677	524106	9	Timeout error of CAN-Receive-Frame ComRxEGRMsFlw1 (EGR actuator)
1678	524107	9	Timeout error of CAN-Receive-Frame ComRxEGRMsFlw2 (EGR actuator)
1679	524109	9	Timeout error of CAN-Receive-Frame ComRxEGRTVActr (EGR actuator)
1680	524111	9	Timeout error of CAN-Receive-Frame ComRxETVActr
1681	524113	9	Timeout error of CAN-Receive-Frame ComRxITVActr
1682	524120	9	Timeout error of CAN-Receive-Frame ComRxSCRHtDiag
1683	524121	9	Timeout error of CAN-Receive-Frame ComRxTrbChActr (wastegate actuator)
1684	524122	9	Timeout error of CAN-Receive-Frame ComRxUQSens (Urea quality)
1685	524123	9	Timeout error of CAN-Receive-Frame ComSCRHtCtl
1686	524124	9	Timeout error of CAN-Receive-Frame ComTxAT1IMG
1687	524125	9	Timeout error of CAN-Receive-Frame ComTxTrbChActr (Wastegate actuator)
1698	524133	2	HMI system; set if restore button blocked
1699	524134	0	DPF, ash load exceeds the shutoff threshold

The texts are given only in the original language version or as a translation of the original into the English language version.

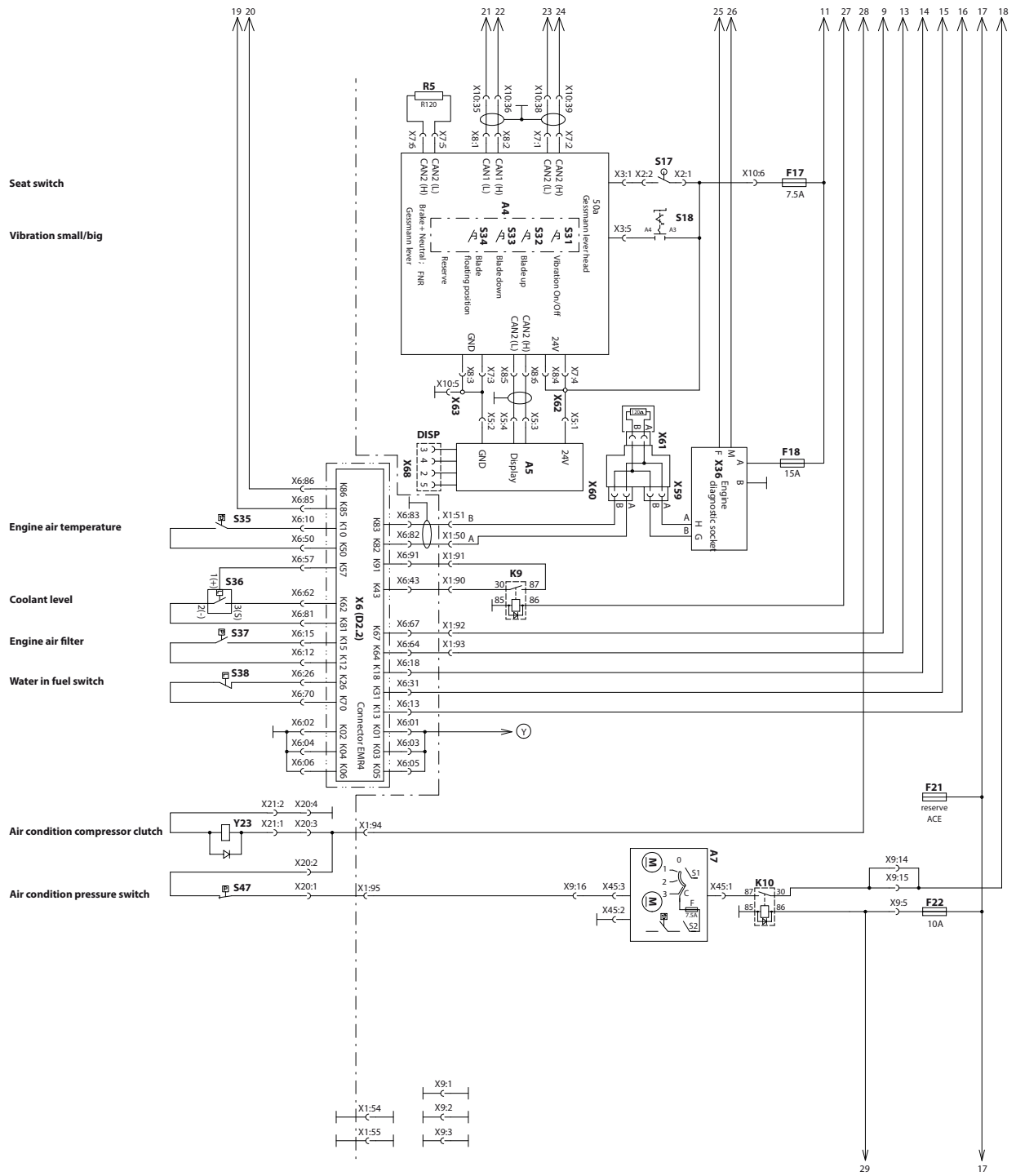

CLICK HERE TO **DOWNLOAD** THE COMPLETE MANUAL

- Thank you very much for reading the preview of the manual.
- You can download the complete manual from: www.heydownloads.com by clicking the link below



- Please note: If there is no response to CLICKING the link, please download this PDF first and then click on it.

CLICK HERE TO **DOWNLOAD** THE COMPLETE MANUAL