

# ARS 130

SINGLE DRUM ROLLER  
DEUTZ TCD3.6 L4  
EU Stage V / U.S. EPA Tier 4f

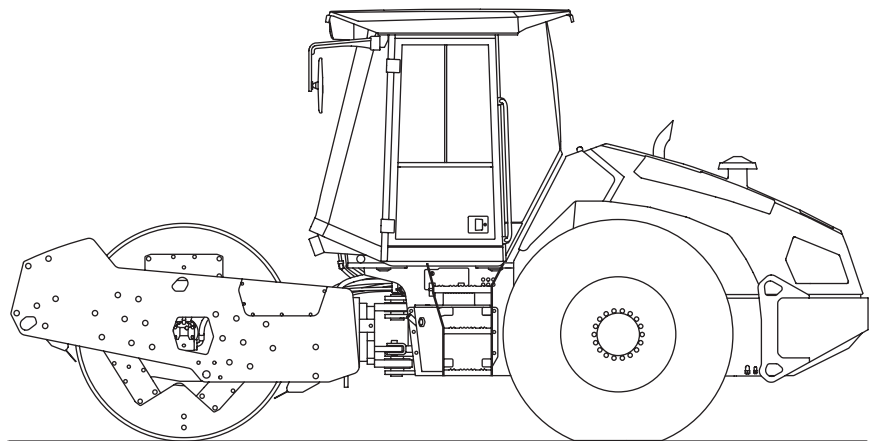

## OPERATING MANUAL

EDITION 01/2021 EN  
Product Identification Number 3001632 -

**AMMANN**

CLICK HERE TO **DOWNLOAD** THE COMPLETE MANUAL

- Thank you very much for reading the preview of the manual.
- You can download the complete manual from: [www.heydownloads.com](http://www.heydownloads.com) by clicking the link below



- Please note: If there is no response to CLICKING the link, please download this PDF first and then click on it.

CLICK HERE TO **DOWNLOAD** THE COMPLETE MANUAL

<b>Every 250 hours of operation (every 3 months).....</b>	<b>156</b>
3.6.14 Checking the sensor of the air filter .....	156
3.6.15 Machine lubrication.....	158
3.6.16 Checking the oil in the vibrator.....	161
3.6.17 Checking the oil in travel gearboxes .....	162
3.6.18 Checking the pad-foot segments .....	163
3.6.19 Seat switch check.....	163
<b>Every 500 hours of operation (every 6 months).....</b>	<b>164</b>
3.6.20 Engine oil change .....	164
3.6.21 Fuel filter replacement.....	167
3.6.22 Air filter cartridges replacement .....	169
3.6.23 DEF (AdBlue) filter replacement .....	171
3.6.24 Engine coolant check.....	174
3.6.25 Replacement of the cab ventilation filter and of the heating filter .....	175
3.6.26 Electrical installation check.....	176
3.6.27 Replacement of the air filter elements of the air conditioning unit.....	176
3.6.28 Checking the wheel screws for tightening.....	176
<b>Every 1,000 hours of operation (yearly) .....</b>	<b>177</b>
3.6.29 Checking the engine belt.....	177
3.6.30 Oil change in travel gearboxes .....	178
3.6.31 Checking the intake pipe of the engine .....	179
3.6.32 Checking the batteries.....	180
3.6.33 Checking the engine .....	181
3.6.34 Damping system check .....	181
3.6.35 Checking the air-conditioning compressor for mounting.....	183
3.6.36 Engine and machine diagnostics.....	183
<b>Every 2,000 hours of operation (every 2 years).....</b>	<b>184</b>
3.6.37 Oil change in the vibrator .....	184
3.6.38 Cleaning and checking the air-conditioning system.....	185
3.6.39 Hydraulic oil and filter replacement.....	186
3.6.40 Cleaning of the suction filter of the cab lifting and lowering unit.....	192
3.6.41 Vent plug replacement .....	193
<b>Every 6,000 hours of operation (every 4 years).....</b>	<b>194</b>
3.6.42 Coolant change .....	194
<b>Maintenance as required .....</b>	<b>196</b>
3.6.43 Fuel system venting .....	196
3.6.44 Regeneration of clogged SCR (Selective Catalytic Reduction) catalyst .....	197
3.6.45 DPF regeneration (Diesel Particulate Filter) .....	199
3.6.46 Cooler cleaning.....	200
3.6.47 Machine cleaning.....	201
3.6.48 Scraper adjustment.....	202
3.6.49 Drum coolant .....	203
3.6.50 Printer paper replacement .....	204
3.6.51 Charging of the battery .....	206
3.6.52 Checking the screw connections for tightening.....	207

Air-conditioning (see Chap. 1.4.1)  
Preparation for antenna radio and loudspeakers  
Radio  
ROPS 2D  
Reverse alarm  
Warning beacon (see Chap. 1.4.2)  
Licence plate holder  
Road traffic lighting (including direction lights)  
Night operation lighting  
ATC inter-axle lock  
Additional padfoot segments (recommended with ATC and tractor tyres) (see Chap. 1.4.3)  
Blade (see Chap. 1.4.4)  
Tyre ballasting with liquid up to -25 °C  
Air pre-filter  
Padlock latch over the fuel tank  
ACEecon  
ACE Force (see Chap. 1.4.5)  
ACE Pro (see Chap. 1.4.9)  
ADS software  
GPS to ACE Pro  
Printer ACE systems  
Telematic preparation  
Telematic (see Chap. 1.4.6)  
Tachograph preparation  
Tachograph (see Chap. 1.4.8)  
Tractor tyres  
Triangle for slow-moving vehicles  
Fire extinguisher (see Chap. 1.4.7)  
Set of filters, 500 h  
Set of filters, 2000 h  
Biodegradable hydraulic oil  
Amman tool kit  
Special colour design  
Certificate of Origin  
Additional documentation set  
Topcon

### **2.1.2 Requirements for the machine driver's qualification**

- Only a driver having been trained according to ISO 7130 and other local and national instructions and standards specified for drivers of such a group of machines is allowed to operate the roller.
- Only the one who learns to drive the machine with the approval of the user for the purpose of getting preliminary practice may drive the machine with no licence, and such a person has to be under direct and continuous surveillance of a professional teacher or trainer.
- The licence (certificate) holder is obliged to take due care of the licence and when requested to submit it to the control authorities.
- The licence holder must not make any records, changes or corrections in the licence card.
- He is obliged to immediately report his lost licence to the authority that issued the licence.
- The roller may be driven without a respective licence independently and for a short term only by a worker who is mentally and physically fit, over 18 years old and is:
  - a) charged by the machine manufacturer with assembling, testing and presenting the machine and possibly with training the drivers whereas he must be familiar with work safety regulations in force at the workplace
  - or
  - b) assigned by the building works contractor for operation (maintenance), trained and practised in a provable manner and/or having the professional qualification to operate and drive the roller in compliance with special provisions (machine operator licence, etc.).
- The machine driver must undergo training and examination concerning the work safety regulations at least once every 2 years.

### 2.1.6 Manual signals

- Signals given by an assistant operator if the operator cannot see the travelling or working area or work devices of the machine.
- The following principles must be observed:
  - For communication purposes, only a limited number of signals must be used.
  - The signals must be clearly distinguishable to prevent any misunderstanding.
  - Hand signals can only be used when ambient conditions allow clear communication between persons.
  - Hand signals must be as similar as possible to intuitive movements.
  - Single-handed signals can be done with any hand.

#### EXAMPLES OF COMMUNICATION SIGNALS:

##### Engine start

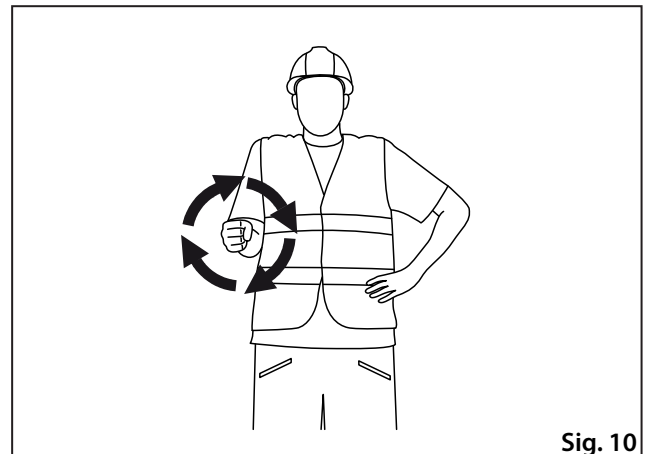

Fig. 10

##### Engine OFF

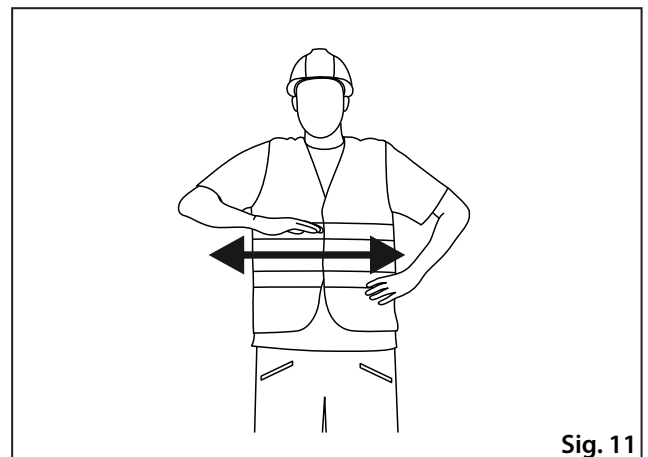

Fig. 11

##### Stop

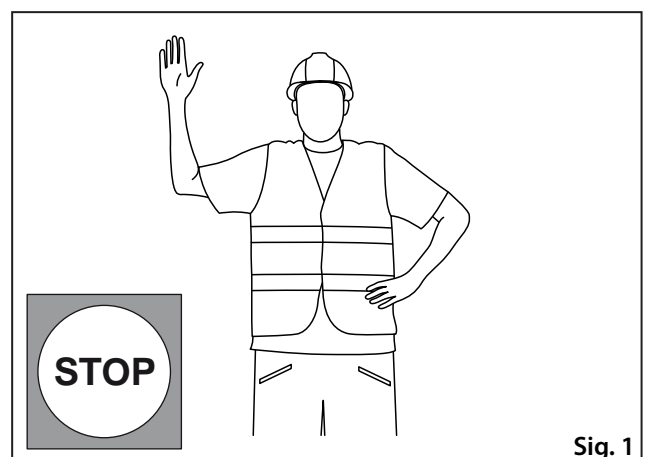
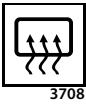

Fig. 1

## Dashboard and control panels

1. Steering wheel
2. Display
3. Travel controller
4. Blade down button (optional)\*
5. Blade up button (optional)\*
6. Vibration button
7. Speed gear increase button
8. Speed gear decrease button
9. Emergency brake button
10. Warning horn button
11. Turn signal light switch
12. Vibration amplitude selector switch
13. Vibration mode selector switch
14. Ignition box
15. Operator seat
16. Rear window heating switch
17. Windscreen washer switch
18. Rear screen wiper switch
19. Front screen wiper switch
20. Additional lights switch
21. Road lights switch (optional)
22. Warning lights switch
23. Warning beacon switch (optional)
24. Air-conditioning switch (optional)
25. Air-conditioning fan speed switch (optional)
26. Heating temperature control
27. Heater fan speed switch
28. Air-conditioning outlets
29. Cab light
30. Fuse box
31. CAN 2 connector
32. CAN 1 connector (Diagnostics)
33. Engine diagnostics
34. Service switch

\* Press the buttons (4) and (5) at the same time to enable the floating position of the blade.



## Rear window heating switch (16)

It is used for turning on the rear window heating; the function is indicated by the indicator lamp in the switch.

The heating runs for 5 minutes after the switch is switched on.

- OFF
- ON



## Windscreen washer switch (17)

- Front windscreen washing ON
- OFF
- Rear windscreen washing ON

After the windscreen is sprayed, it is wiped twice.



## Rear screen wiper switch (18)

- OFF
- Intermittent
- Continuous wiping

The wiping interval of 5 sec. is set automatically by changing the switch from OFF to Intermittent. You can readjust the interval by changing the switch to OFF and then after a required time (from 0.5 to 60 sec.) back to the Intermittent position.



## Front screen wiper switch (19)

- OFF
- Intermittent
- Continuous wiping

The wiping interval of 5 sec. is set automatically by changing the switch from OFF to Intermittent. You can readjust the interval by changing the switch to OFF and then after a required time (from 0.5 to 60 sec.) back to the Intermittent position.



## Additional lights switch (20)

It is used for turning on/off the additional lights.

- OFF
- Front lights
- Front and rear lights



## Road lights switch (21) (optional equipment)

It is used for turning on/off the road lights.

- OFF
- Outline lights
- Dipped lights



## Warning lights switch (22)

It is used for turning on/off the warning lights – the function is indicated by flashing the indicator lamp in the warning light switch.



## Warning beacon switch (23) (optional equipment)

It is used for turning on/off the warning beacon.

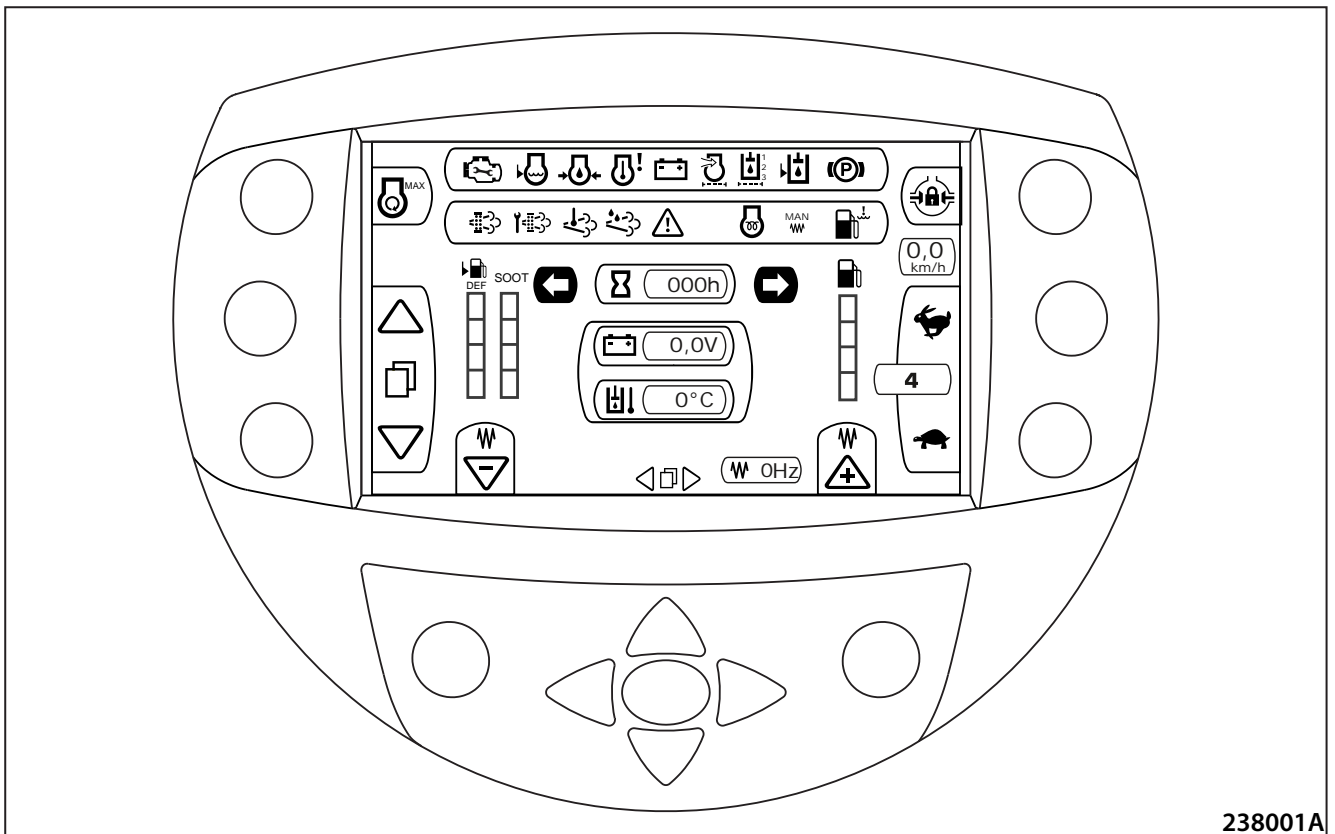

238001A

### 2.6.1 Display control – operation screen

It is used for controlling the machine and getting information during operation of the machine.



#### Maximum engine speed button

It is used for setting the engine operating speed.



**Brake test button**

It is used for checking the machine brakes for correct operation (the operator is prompted to check the brakes every 24 hours).

After you press the brake test button, a confirmation dialog will appear.

Press the middle button (A) to confirm the start of the brake test.

Press the lower button (B) to cancel the start of the brake test.



**Perform the brake test according to Chapter 3.6.12.**

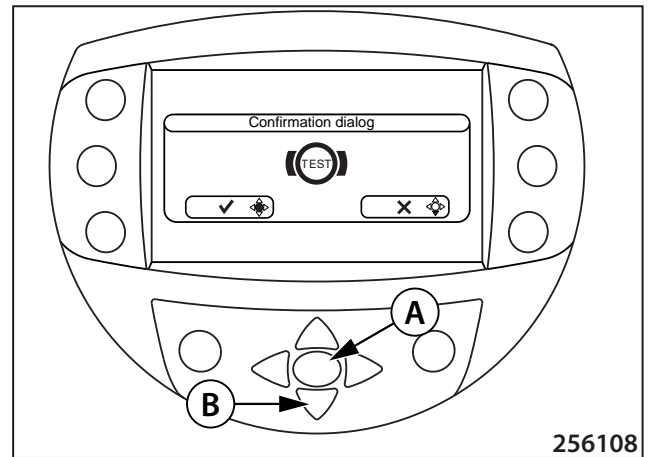

**Regeneration button**

It is used for enabling the DPF regeneration.

After you press the regeneration button, a confirmation dialog will appear.

Press the middle button (A) to confirm the start of the DPF regeneration.

Press the lower button (B) to cancel the start of the DPF regeneration.

After the start of the DPF regeneration is confirmed, the following information dialog will appear:

- DPF regeneration enabled
- it is forbidden to move with the travel control

**Note**

The dialogue will appear when the DPF regeneration is started or if the function is enabled and the operator has not pressed any button for more than 60 seconds.

The dialogue can be confirmed by pressing the middle button (A).

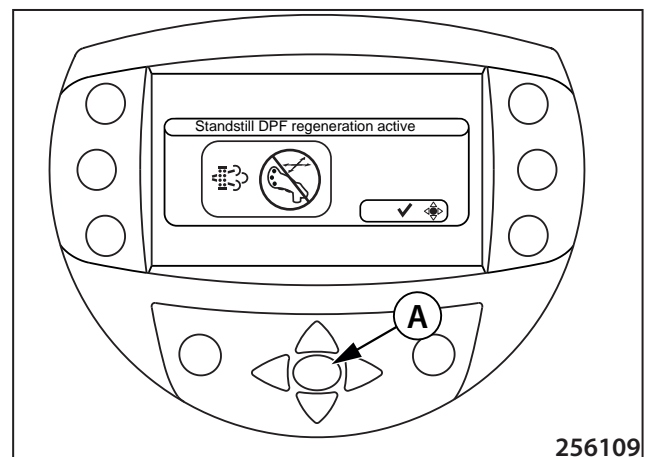
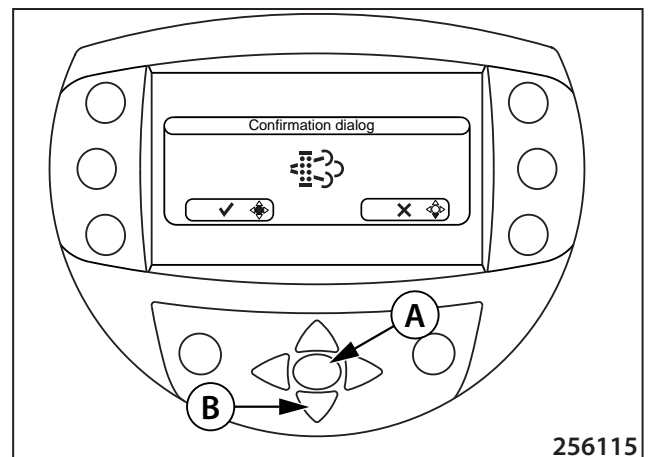

If the blue turtle icon appears on the display after starting, the machine can be operated in the cold start mode.

## Cold start mode

If the engine temperature is lower than 20 °C and the hydraulic oil temperature lower than 15 °C, the machine can be operated in the limited operation.

- Max. engine speed 1300 RPM
- Engaged speed gear „0“
- Vibration OFF

A low temperature of the engine is indicated by the blue indicator lamp of the engine temperature.

To warm up the machine, drive the machine back and forth alternately to a distance of 10 meters and turn the drum left and right as shown in the figure.



**Do not warm up a stationary machine while idling; there is a risk of engine damage!**

The mode is switched off after the engine temperature reaches 20 °C, the hydraulic oil temperature 15 °C. And you set the travel control (3) to the parking brake position "P".

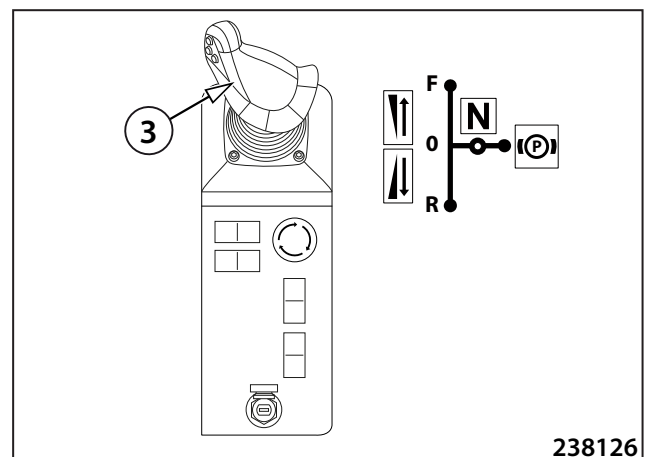
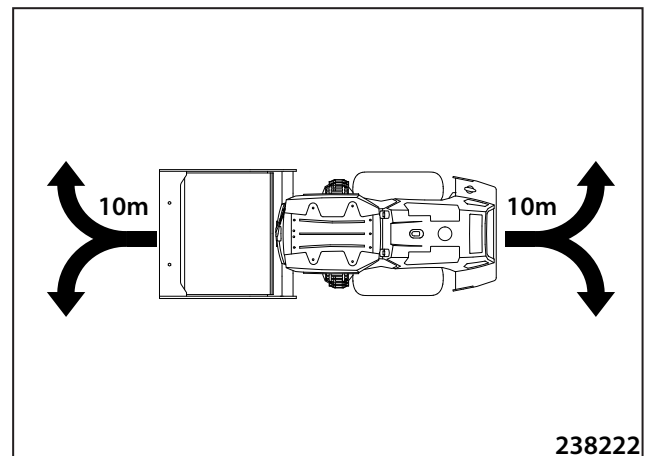
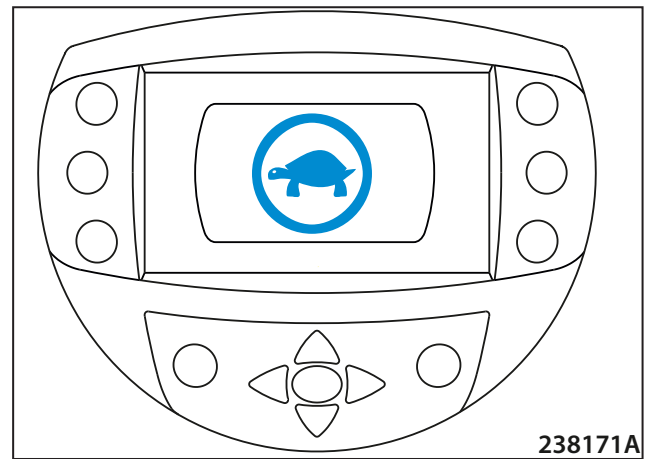

### 2.7.3 Stopping the machine and engine

- Press the button (6) on the travel control (3) to switch off the vibration.
- Stop the machine by changing the travel control (3) to the neutral position (N).
- Brake the machine by changing the travel control (3) to the brake position (P).
- Turn the key in the ignition box (14) to position "0" and close the cap of the ignition box.



**Do not stop the hot engine instantly but let it idle for 3 minutes. The engine and the turbocharger will cool down slowly and evenly!**

**The travel control (3) must be always in the brake position (P)!**

**Turn off the battery disconnecter when shutting down the machine!**

---

### 2.7.4 Machine emergency stop



**Use in a dangerous situation when you cannot stop the machine by enabling the panic response or by moving the travel control (3) to the brake position (P) or if there is a failure when it is impossible to stop the engine with the key in the ignition box!**

---

#### **Turning on:**

- After pressing the emergency brake button (9), the machine is braked and the engine stops.
- The emergency brake indicator lamp lights up on the display (2).

#### **Turning off:**

- Turn the emergency brake button (9) in the direction of arrows.
- The emergency brake indicator lamp will go off.
- The parking brake indicator lamp keeps lighting on the display.
- Move the travel control (3) to the position (P); you can restart the engine in this position.

**Draining procedure:**

- Place the machine on a solid and flat surface. Drive the machine with tyres onto the surface so that the filling valve is in the lowest position. Use scotch blocks to secure the drum from both sides.
- Unscrew the detachable valve insert and the solution will run out.



**When you remove the valve insert, the solution may splash out.**

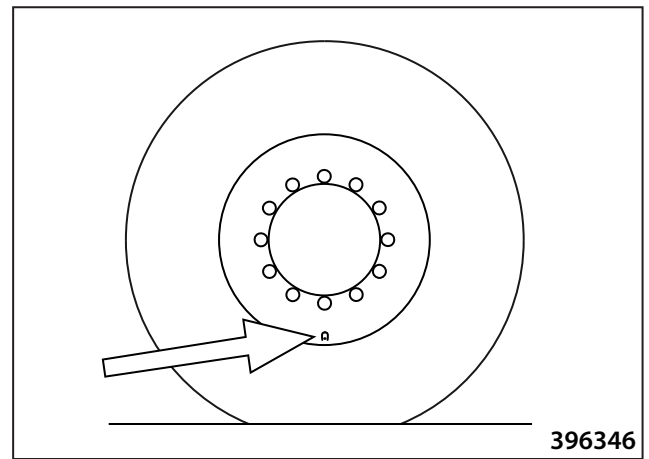

396346

- As soon as the pressure drops so much that almost no solution is running out, screw on the filling adapter and pump up the tyre to the pressure of 160 kPa (23.2 PSI).
- When the tyres are filled up, take out the filling adapter and screw on the valve insert back.



**Protect your eyes with glasses (protective shield) and hands with rubber gloves!**



**Wash the spilt solution with clean water.  
The solution must not come in contact with metal parts and the wiring.**

## 2.9.2 Towing the machine

- For towing, the machine is provided with two towing lugs on the drum frame and with two towing lugs on the rear frame.
- A stuck machine can be towed for a short distance if the engine is running and the travel drive and steering are working.



**The towed machine must be attached to both tow lugs.**  
**For towing, use undamaged tow ropes or tow bars of a sufficient capacity 1.5 × higher than the weight of the towed vehicle. Do not use a chain for the towing.**

**It is necessary to maintain the minimal angular deviation from the direction of towing. The maximum possible angular deviation is 30°.**

**Smooth and constant movement must be maintained in towing. Do not exceed the towing speed by more than 1 km/hour (0.62 mph).**

**Tow the roller at the shortest distance possible – to rescue when it gets stuck or to remove when it is broken and obstructing. Do not tow for a distance exceeding 300 m (0.19 miles).**

**The towing machine should correspond with its size to the damaged machine. It must have a sufficient traction power (output), weight, and brake effect.**

**While towing downhill using a rope, another towing machine must be connected to the rear part of the damaged machine. In this way you can prevent an uncontrolled motion of the damaged machine.**

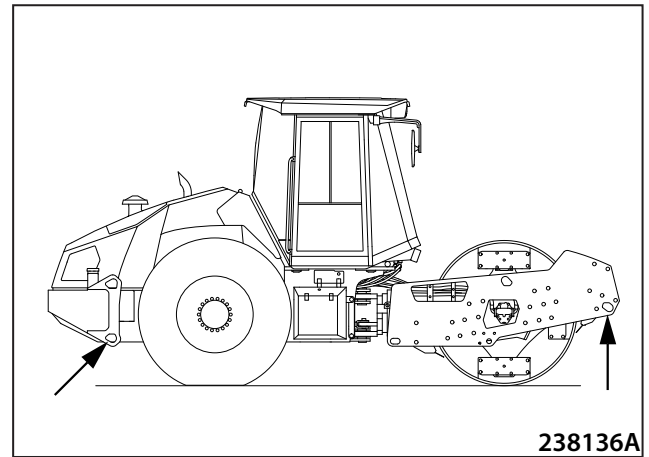

- If the engine does not work, or there is a defect in the hydraulic system, then you must short-circuit the hydraulic circuit and release the brake of the machine. Then the machine can be towed.



**No person may stay on the towed machine!**

**After the hydraulic circuit of the travel is short-circuited and the machine brakes are released, all of the brakes are disabled!**

**Before releasing the brake, secure the machine with wooden scotch blocks against movement!**

**The cab (platform) and the bonnet must be lowered down before the brakes are released.**

**Do not touch hot parts of the machine, there is a burn hazard!**

CLICK HERE TO **DOWNLOAD** THE COMPLETE MANUAL

- Thank you very much for reading the preview of the manual.
- You can download the complete manual from: [www.heydownloads.com](http://www.heydownloads.com) by clicking the link below



- Please note: If there is no response to CLICKING the link, please download this PDF first and then click on it.

CLICK HERE TO **DOWNLOAD** THE COMPLETE MANUAL

## 3.1 Safety and other measures during maintenance of the machine

---

### 3.1.1 Safety during machine maintenance

Carry out lubrication, maintenance and adjustment as follows:

- By professionally trained personnel;
- According to safety instructions given in the operating manual;
- In intervals given in the lubrication chart after hours worked;
- On the machine standing on a flat and solid surface and secured against movement (with scotch blocks), always with the engine off, the key removed from the ignition box and the wiring disconnected;
- When the tag **Machine repair** is attached on the steering wheel (the tag is delivered with the machine accessories);
- At cold machine parts;
- After the machine, lubrication points and maintenance places have been cleaned;
- Using suitable, undamaged tools;
- By replacing parts with new original parts according to the spare parts catalogue;
- By providing sufficient lighting of the entire machine during poor visibility and at night;
- By reinstalling all removed covers and safety elements after the work is completed;
- By retightening screw connections to the specified tightening torque and checking the connections for leakage;
- After the operating fluids are heated – beware of burns – use only recommended media.



---

**After the adjustment or maintenance is completed, check all safety devices for proper operation!**

---

### 3.1.2 Fire protection when operating fluids are changed

- Considering the fire danger, the flammable liquids used on the machine are divided into the following hazard classes:
  - II hazard class – diesel fuel
  - IV. hazard class – mineral oils, lubricating greases
- The oil change point must be where it cannot interfere in explosion or fire hazard areas.
- It must be identified by “No smoking” and “No open fire” plates and signs.
- The handling area must be dimensioned so that it can catch a volume of the flammable liquid equal to the capacity of the biggest vessel, transport container.
- It must be equipped with portable fire extinguishers.
- For handling oils and diesel fuel, use vessels such as metal barrels, jerrycans and sheet-metal cans.
- The transport containers must be properly closed during storage.
- The containers must be provided with one hole, always stored with the hole up and secured so that their content cannot flow out and drip off.
- Vessels must be marked with non-removable writings showing the contents and flammability classes.

<b>Maintenance as required</b>	
3.6.43	Fuel system venting
3.6.44	SCR catalyst regeneration (Selective Catalytic Reduction)
3.6.45	DPF regeneration (Diesel Particulate Filter)
3.6.46	Cooler cleaning
3.6.47	Machine cleaning
3.6.48	Scraper adjustment
3.6.49	Drum coolant
3.6.50	Printer paper replacement
3.6.51	Charging of the battery
3.6.52	Checking the screw connections for tightening
<p>* <b>First after 100 hours</b></p> <p>** <b>First after 500 hours</b></p>	

**3.6.6 Checking the fan for condition**

- Check the fan visually. Replace the fan if damaged (e.g. missing parts of materials, cracks, shape changes, etc.).



**3.6.7 Checking the dust valve of the air filter**

- Clean the exit slit and squeeze to remove any dust trapped.

**Note**

Any dust trapped in the dust valve is automatically emptied during operation of the machine.



**Do not work with the machine if the dust valve is damaged.**

**If the dust valve of the air filter is damaged, replace it with a new valve of the same type!**



**Dust valve**

Order number: 1-952454

- Check and clean the pre-filter bowl.

**Note:**

The pre-filter is mounted on special order.



- If the indicator lamp does not light up, check the vacuum switch, contacts and supply cables.

---

**Sensor**

Order number: 4-5358520063

---

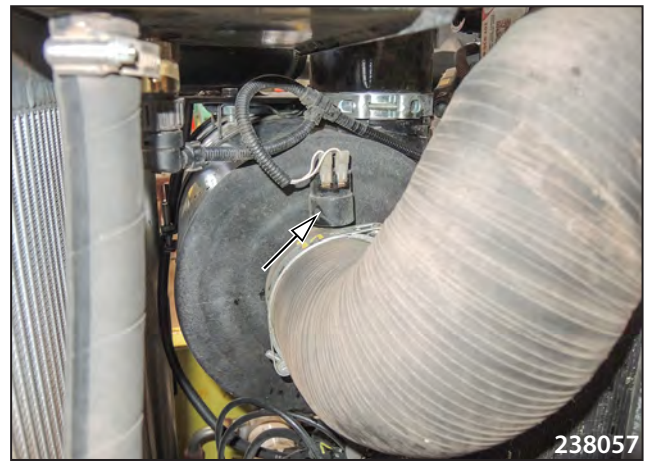

### 3.6.21 Fuel filter replacement

#### Fuel filter

- Clean the fuel filter head.
- Remove the filter.



- Lubricate the seal ring of the new filter with oil.

#### Fuel filter

Order number: 1238008

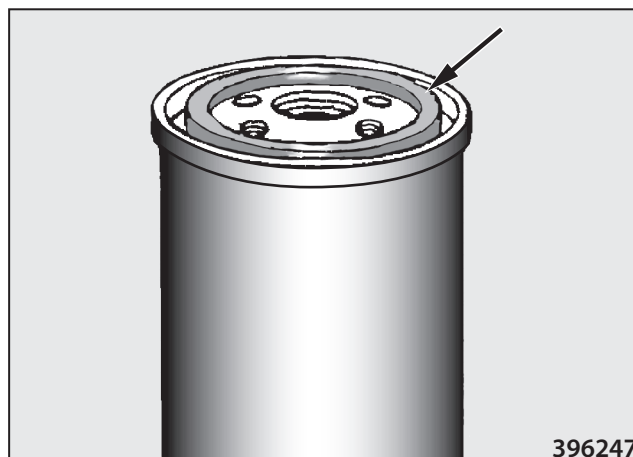

- Retighten the filter by 3/4 revolution after the filter is in position.
- Tightening torque 10–12 Nm (7.4–8.9 lb ft).

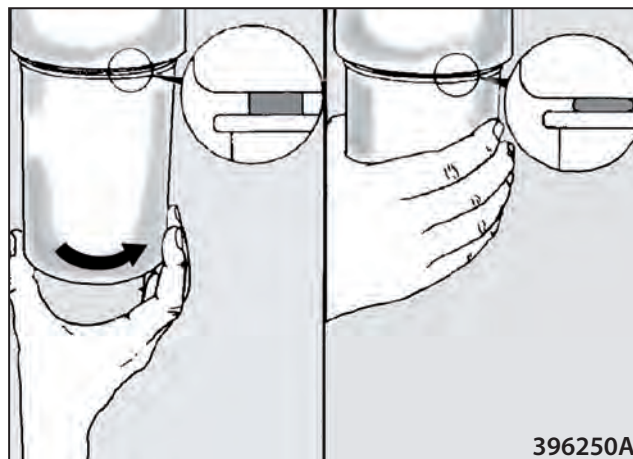

#### Fuel pre-filter

- Disconnect the connector of the water separator sensor.



Every 1,000 hours of operation (yearly)

### 3.6.29 Checking the engine belt

#### Checking the engine belt for wear:

- Visually inspect the belt.
- Cracks perpendicular to the belt width are not considered to be a fault. If longitudinal cracks appear on the belt, or the belt edges are ragged, or some material parts are pulled off, then the belt must be replaced.

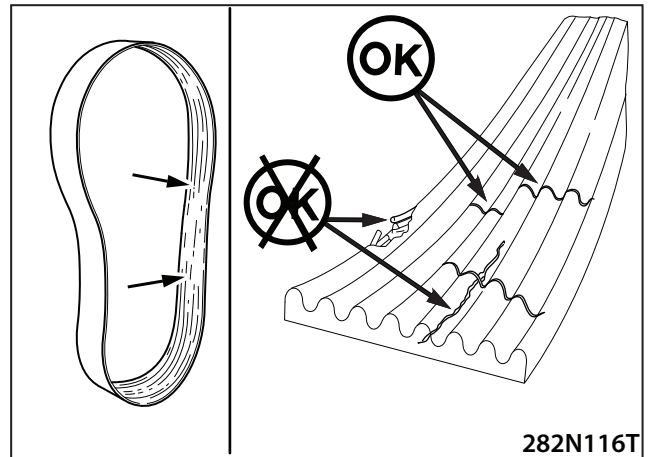

#### Replacing the air-conditioning belt:

- Loosen the screws and move the compressor.
- Take out the air-conditioning belt.

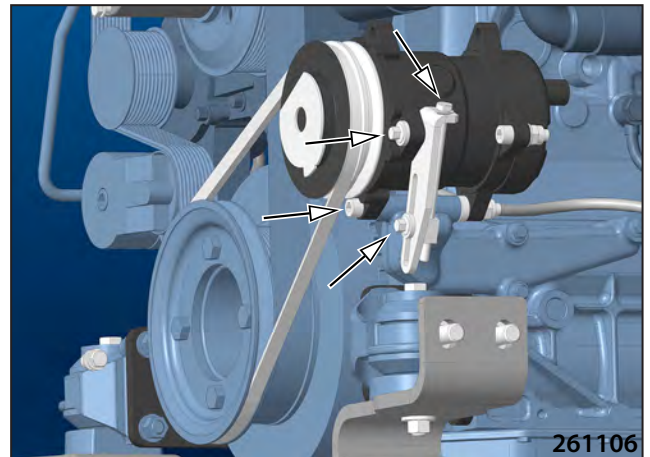

#### Replacing the engine belt:

- Lift off the tension pulley of the belt using a square lever.
- Take out the engine belt.
- Insert the new belt.



**Change and tension the belt when the engine is not running!**

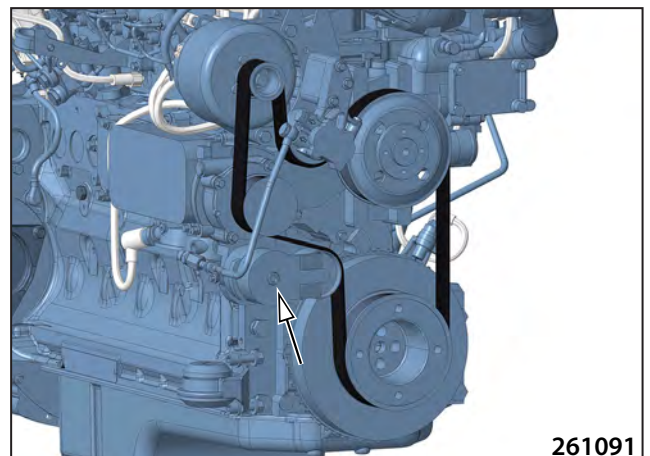

- Remove the connector of the level gauge.

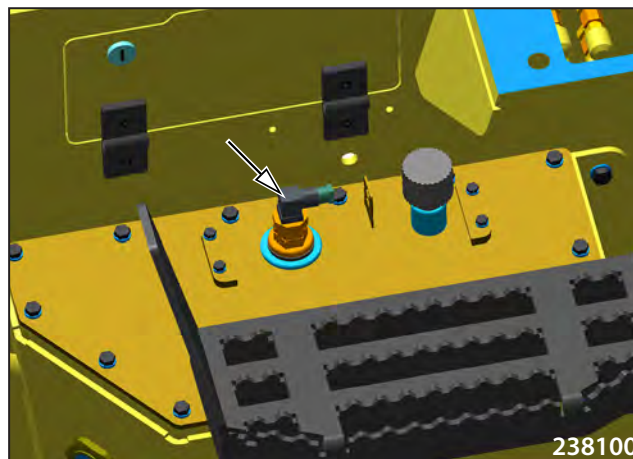

- Remove the cap.

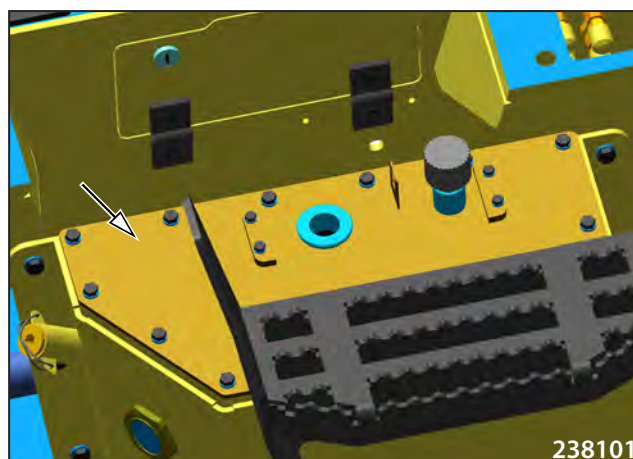

- Remove the suction basket.
- Clean the suction basket.
- Remount the suction basket.
- Inspect the interior of the tank.
- If the bottom is dirty, clean and rinse the tank carefully with the new oil.
- Mount the lid back.
- Use the new sealing tape.

**Sealing strip**

Order number: 4-5422250006

- Remount the connector of the level gauge.

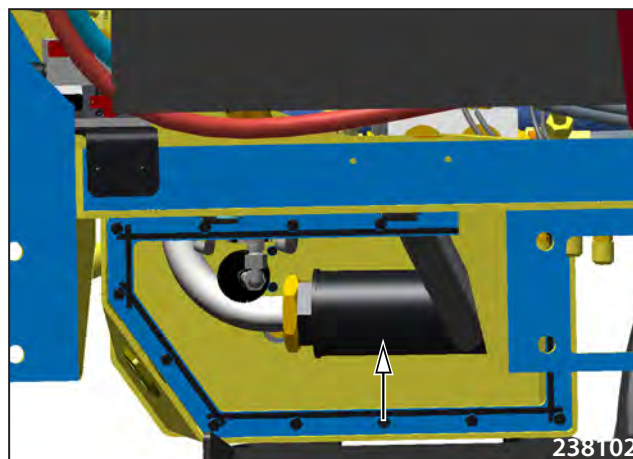

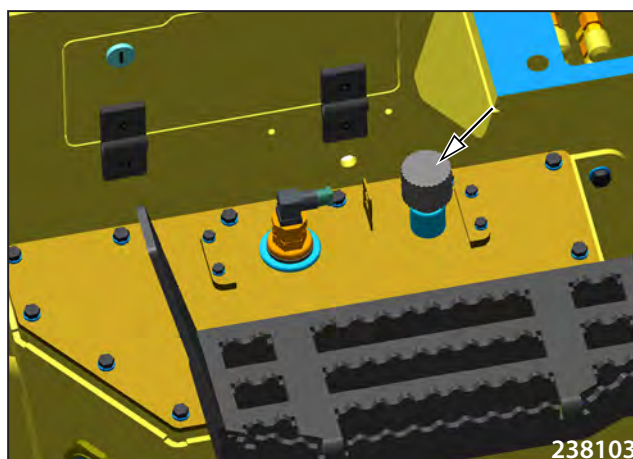

- Remove the ventilation filter. Mount a new ventilation filter.
- Mount the cover back.



**3.6.44 Regeneration of clogged SCR (Selective Catalytic Reduction) catalyst**

- Regeneration is a special engine mode, during which the machine cannot be used.
- Regeneration is made through dissolution of DEF (AdBlue) crystals in the SCR catalyst.
- The regeneration is fully controlled by the engine control unit and it is recommended to wait until the regeneration process is completed.

	<b>Conditions for start of regeneration</b>	<b>Indication lamp of SCR catalyst clogging</b>  AMN118	<b>Engine failure indicator lamp</b>  AMN47	<b>Sound signal</b>	<b>Machine reactions</b>
Normal operation	No need for regeneration	Off	no	no	No
Crystallisation detection	Machine at standstill and regeneration button	Flashing slowly 0.5 Hz	no	no	No
Crystallisation detection warning	Machine at standstill and regeneration button	Flashing slowly 0.5 Hz	lighting	Yes	Engine output reduced by 25 %
Crystallisation detection OFF	Machine idle and service tools required	Flashing rapidly 3 Hz	Flashing	Yes	Output reduced to 50 % + max. engine speed reduced to 1300 rpm.

**Regeneration conditions:**

- Park the machine at a safe area.
- The travel control level in the brake position
- Coolant temperature >70 °C
- Sufficient fuel volume – about 20 l (5.3 gal US)
- Sufficient volume of DEF (AdBlue) (Diesel exhaust fluid) – about 1 l (0.26 gal US).

**3.6.52 Checking the screw connections for tightening**

- Check regularly the screw connections for loosening. Use torque spanners for tightening.

Thread	Tightening torque				Thread	Tightening torque			
	For screws 8.8 (8G)		For screws 10.9 (10K)			For screws 8.8 (8G)		For screws 10.9 (10K)	
	Nm	lb ft	Nm	lb ft		Nm	lb ft	Nm	lb ft
M6	10	7.4	14	10.3	M18×1.5	220	162.2	312	230.1
M8	24	25.0	34	25.0	M20	390	287.6	550	405.6
M8×1	19	14.0	27	19.9	M20×1.5	312	230.1	440	324.5
M10	48	35.4	67	49.4	M22	530	390.9	745	549.4
M10×1.25	38	28.0	54	39.8	M22×1.5	425	313.4	590	435.1
M12	83	61.2	117	86.2	M24	675	497.8	950	700.6
M12×1.25	66	48.7	94	69.3	M24×2	540	398.2	760	560.5
M14	132	97.3	185	136.4	M27	995	733.8	1400	1032.5
M14×1.5	106	78.2	148	109.1	M27×2	795	586.3	1120	826.0
M16	200	147.5	285	210.2	M30	1350	995.7	1900	1401.3
M16×1.5	160	118.0	228	168.1	M30×2	1080	796.5	1520	1121.0
M18	275	202.8	390	287.6					

Values given in the table are tightening torques for dry threads (friction coefficient = 0.14). The values are not applicable to lubricated threads.

**Table of tightening torques of cap nuts with sealing O-rings – hoses**

			Tightening torques of cap nuts with O-rings – hoses					
			Nm			lb ft		
Spanner size	Thread	Pipe	Nominal	Min	Max	Nominal	Min	Max
14	12×1.5	6	20	15	25	15	11	18
17	14×1.5	8	38	30	45	28	22	33
19	16×1.5	8	45	38	52	33	28	38
		10						
22	18×1.5	10	51	43	58	38	32	43
		12						
24	20×1.5	12	58	50	65	43	37	48
27	22×1.5	14	74	60	88	55	44	65
		15						
30	24×1.5	16	74	60	88	55	44	65
32	26×1.5	18	105	85	125	77	63	92
36	30×2	20	135	115	155	100	85	114
		22						
41	36×2	25	166	140	192	122	103	142
46		28						
50	42×2	30	240	210	270	177	155	199
50	52×2	35	290	255	325	214	188	240
		38						
		42						

**3.7.7 Engine errors**

<b>Error codes</b>	<b>SPN</b>	<b>FMI</b>	<b>Error description</b>
8	132	1	„The air mass flow AFS_dm is greater than or equal to AFS_PhysRng.Min_C. Physical range check is low for air mass flow sensor.“
9	172	2	Air inlet filter temperature, plausibility error.
26	523891	14	„When AirHt_ctDefSRCLoOn_mp is lower than AirHt_ctMaxDef_C. DFC to SRC Low error when heater is on.“
28	523953	2	„Healing takes place if the condition for error detection is not present. Air temprature monitoring plausibility check array.“
30	523955	2	„Healing takes place if the condition for error detection is not present. Air temperature monitoring plausibility check array.“
36	523923	3	
37	523924	3	Short circuit to battery error of actuator relay 2.
38	523925	3	Short circuit to battery of actuator relay 3.
40	523927	3	Short circuit to battery of actuator relay 6.
41	523923	4	„Short circuit to ground error. Detailinformation not available.“
42	523924	4	Short circuit to ground of actuator relay 2.
43	523925	4	Short circuit to ground of actuator relay 3.
44	523926	4	Short circuit to ground of actuator relay 4.
45	168	3	Sensor battery voltage error; signal range check is high.
46	168	4	Sensor battery voltage error; signal range check is low.
47	168	2	High battery voltage; warning threshold is exceeded.
48	168	2	High battery voltage; Shot off threshold exceeded.
55	523910	14	„Air pump doesn't achieve air mass flow setpoint. Burner Control - burner air pump“
56	524013	7	„Burner does not start after several trials (burner flame lost detection). Burner flame unintentional deleted.“
57	524020	14	„Burner Control: Power reduction due to low lambda. Engine power: Not enough oxygen for regeneration.“
58	523911	0	„Burner dosing valve (DV2); Overcurrent at the end of the injection phase.“
59	523911	12	Burner dosing valve (DV2); Powerstage over temperature.
60	523911	3	Burner dosing valve (DV2); Short circuit to battery.
62	523911	4	Burner dosing valve (DV2); Short circuit to ground.
63	523911	11	„Burner dosing valve (DV2); Short circuit high side powerstage.“
64	523912	2	„Burner dosing valve (DV2) downstream pressure sensor; plausibility error.“
66	523912	0	„Physical range check high for burner dosing valve (DV2) downstream pressure; Shut off regeneration.“
69	523912	1	„Physical range check low for burner dosing valve (DV2) downstream pressure; Shut off regeneration. When burner injector is actuated, the measured pressure does not rise above 1250mbar abs (expected: about 2400mbar).“

The texts are given only in the original language version or as a translation of the original into the English language version.

Error codes	SPN	FMI	Error description
893	4343	11	„SCR Monitoring; Pressure stabilisation error, general pressure check error (SCR)“
894	4374	13	Pressure stabilisation error dosing valve (SCR)
897	523632	16	Pump pressure SCR metering unit too high.
898	523632	18	Pump pressure SCR metering unit too low
899	523632	0	Pressure overload of SCR-System.
900	523632	1	Pressure build-up error SCR-System.
903	4365	0	DEF tank temperature too high.
905	3241	0	„Sensor SCR catalyst upstream temperature too high; plausibility error.“
908	3361	7	DEF dosing valve blocked (SCR)
914	523720	2	„DEF supply module heater temperature; plausibility error (normal condition).“
915	523720	2	„Sensor DEF supply module heater temperature; plausibility error (cold start condition)“
916	523721	2	„Sensor DEF supply module temperature; plausibility error (normal condition)“
917	523721	2	„Sensor DEF supply module temperature; plausibility error (cold start condition)“
918	523981	11	„SCR plausibility, OBD and diagnosis; Stuck in range check of DEF tank temperature sensor DEF-tank without heating function (heating phase)“
919	523330	14	Immobilizer status; fuel blocked
920	523330	14	„DFC to block the fuel by Sia No detail informationen!“
921	523330	14	„DFC to indicate that TEN-code or UC-code received if ECU is learned. No detail informationen!“
922	523330	14	„DFC to indicate that no code is received via CAN. No detail informationen!“
923	523330	14	„DFC to indicate that wrong code is received. No detail informationen!“
925	523720	8	„DEF supply module heater temperature; duty cycle in failure range.“
926	523720	8	„DEF supply module heater temperature; duty cycle in invalid range.“
927	523721	11	Urea supply module temperature measurement not available.
928	523722	8	DEF supply module PWM signal; period outside valid range.
929	523722	8	Detect faulty PWM signal from Supply Modul.
930	523721	8	DEF supply module temperature; duty cycle in failure range.
931	523721	8	Urea supply module temperature; duty cycle in invalid range.
932	29	3	Handthrottle idle validation switch; short circuit to battery
935	91	3	„Sensor error accelerator pedal. Signal range check high.“
937	29	4	Handthrottle; short circuit to ground
940	91	4	„Sensor error accelerator pedal. Signal is below the range.“
942	523921	3	Sensor error burner temperature; signal range check high
943	3532	3	ensor error DEF tank level; signal range check high
944	523921	4	Sensor error burner temperature; signal range check low
945	3532	4	Sensor error DEF tank level; signal range check low

The texts are given only in the original language version or as a translation of the original into the English language version.

Error codes	SPN	FMI	Error description
1654	1761	14	„Urea Tank Signal to HMI for indicating the Urea Tank-Level (Urea tank volume ratio low threshold 1)“
1655	1761	14	DEF tank, DEF level below first warning threshold
1656	1761	14	DEF tank, DEF level below second warning threshold
1658	524096	14	„Control of the SCR system; If the start stop counter (EPA-Counter) exceeds the threshold SCRctl_ctEngStrtStopThresh_C. This counter will increment only once in each driving cycle in case of an SCR error. If the counter reaches the threshold, the DFC will be set to inhibit the engine start Engine will not be started, because of EPA-Counter“
1659	524114	9	Timeout error of CAN-Transmit-Frame A1DOC
1660	524115	9	Timeout error of CAN-Transmit-Frame AT1S
1661	524116	9	Timeout error of CAN-Transmit-Frame SCR2“
1662	524117	9	Timeout error of CAN-Transmit-Frame SCR3“
1663	524097	9	Timeout error of CAN-Transmit-Frame DPFBrnAirPmpCtl
1664	524098	9	Timeout error of CAN-Transmit-Frame ComDPFBrnPT
1665	524099	9	Timeout error of CAN-Transmit-Frame ComDPFC1
1666	524100	9	Timeout error of CAN-Transmit-Frame ComDPFHisDat.
1667	524101	9	Timeout error of CAN-Transmit-Frame ComDPFtstMon
1668	524105	9	„Timeout error of CAN-Transmit-Frame ComEGRMsFlw (EGR Steller)“
1669	524108	9	„Timeout error of CAN-Transmit-Frame ComEGRTVActr (EGR actuator)“
1670	524110	9	Timeout error of CAN-Transmit-Frame ComETVActrTO.
1671	524112	9	Timeout ComIntake Throttle Valve Actr.
1672	524118	9	Timeout error of CAN-Receive-Frame ComRxCM1
1675	524103	9	Timeout error of CAN-Receive-Frame ComRxDPFBrnAirPmp
1676	524104	9	Timeout error of CAN-Receive-Frame ComRxDPFctl.
1677	524106	9	„Timeout error of CAN-Receive-Frame ComRxEGRMsFlw1 (EGR actuator)“
1678	524107	9	„Timeout error of CAN-Receive-Frame ComRxEGRMsFlw2 (EGR actuator)“
1679	524109	9	„Timeout error of CAN-Receive-Frame ComRxEGRTVActr (EGR actuator)“
1680	524111	9	Timeout error of CAN-Receive-Frame ComRxETVActr
1681	524113	9	Timeout error of CAN-Receive-Frame ComRxITVActr
1682	524120	9	Timeout error of CAN-Receive-Frame ComRxSCRHtDiag“
1683	524121	9	„Timeout error of CAN-Receive-Frame ComRxTrbChActr (wastegate actuator)“
1684	524122	9	„Timeout error of CAN-Receive-Frame ComRxUQSens (Urea quality)“
1685	524123	9	Timeout error of CAN-Receive-Frame ComSCRHtCtl“
1686	524124	9	Timeout error of CAN-Receive-Frame ComTxAT1IMG“
1687	524125	9	„Timeout error of CAN-Receive-Frame ComTxTrbChActr (Wastegate actuator)“
1698	524133	2	HMI system; set if restore button blocked
1699	524134	0	DPF, ash load exceeds the shutoff threshold
1700	524134	0	DPF, ash load exceeds the warning threshold

The texts are given only in the original language version or as a translation of the original into the English language version.

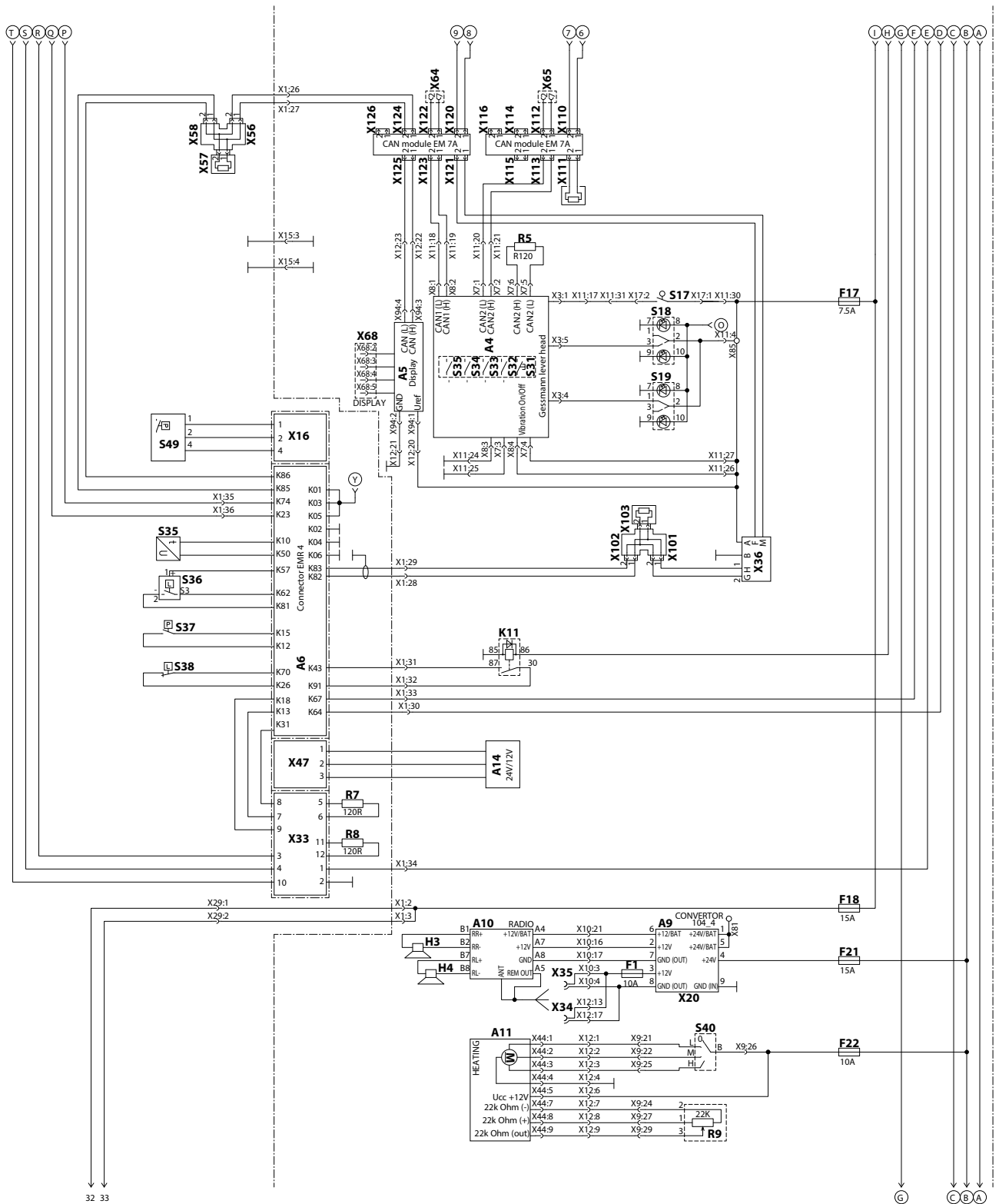

32 33

CLICK HERE TO **DOWNLOAD** THE COMPLETE MANUAL

- Thank you very much for reading the preview of the manual.
- You can download the complete manual from: [www.heydownloads.com](http://www.heydownloads.com) by clicking the link below



- Please note: If there is no response to CLICKING the link, please download this PDF first and then click on it.

CLICK HERE TO **DOWNLOAD** THE COMPLETE MANUAL