

SKYJACK™ OPERATING MAINTENANCE & PARTS MANUAL



SJ-1000 SERIES Engine Powered



Printed in U.S.A.

SKYJACK CORP. (USA)

3451 Swenson, St. Charles, Illinois 60174 Tel: 1-800-275-9522 Fax: (630) 262-0006

SKYJACK INC.

55 Campbell Road, Guelph, Ontario N1H 1B9 Tel: (519) 837-0888 Fax: (519) 837-3102

104322-1

Revised 2-1-96

CLICK HERE TO **DOWNLOAD** THE COMPLETE MANUAL

- Thank you very much for reading the preview of the manual.
- You can download the complete manual from: www.heydownloads.com by clicking the link below



- Please note: If there is no response to CLICKING the link, please download this PDF first and then click on it.

CLICK HERE TO **DOWNLOAD** THE COMPLETE MANUAL

PLATFORM CONTROLS (Figure 1-7)
Operator's Control Box

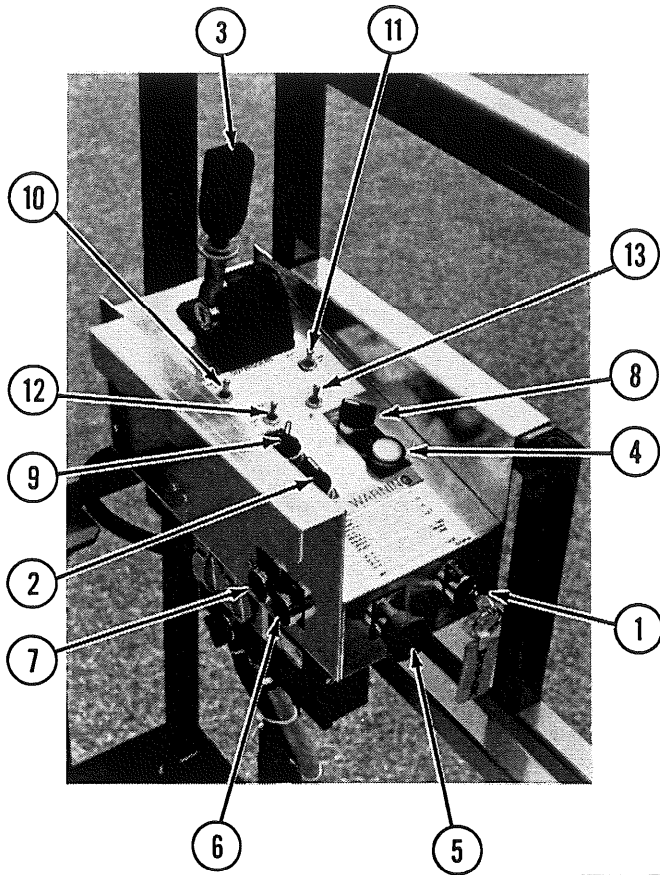

1. LIFT/DRIVE SELECT KEY SWITCH
2. UP/DOWN SELECT SWITCH
3. DRIVE/STEER CONTROLLER
4. PLATFORM POWER INDICATOR LIGHT
5. EMERGENCY STOP BUTTON
6. ENGINE START PUSHBUTTON
7. ENGINE CHOKE PUSHBUTTON
8. LOW/HIGH THROTTLE SELECT SWITCH

(On machines with hydraulic outriggers:)

9. OUTRIGGER ON/OFF SWITCH
10. LEFT FRONT OUTRIGGER CONTROL SWITCH
11. RIGHT FRONT OUTRIGGER CONTROL SWITCH
12. LEFT REAR OUTRIGGER CONTROL SWITCH
13. RIGHT REAR OUTRIGGER CONTROL SWITCH

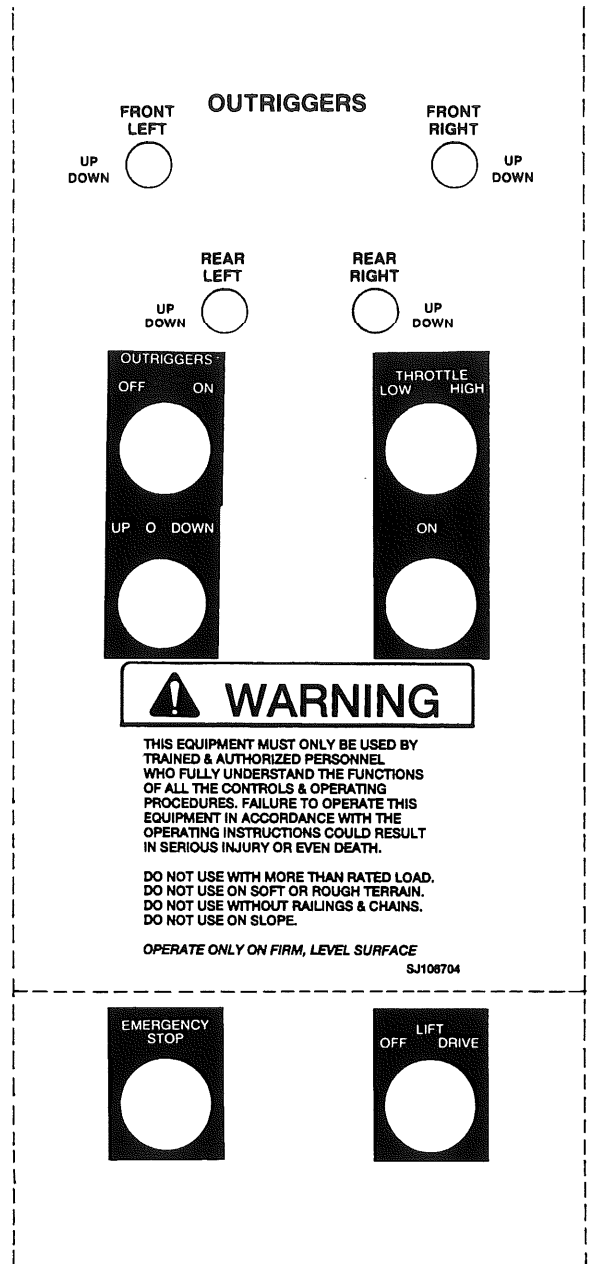
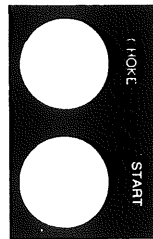

*Figure 1-7. Operator's Control Box and Labels
 (Located at Right Front of Platform)*

SECTION 3

SYSTEM COMPONENT IDENTIFICATION AND SCHEMATICS

TABLE OF CONTENTS

HYDRAULIC SYSTEM

HYDRAULIC DIAGRAMS

Model 8826 (1007-20)	3-3
Model 8838F, 9238, 9238F (1011-20A, 1011-20HD)	3-4
Model 9250 (1015-20)	3-7

HYDRAULIC DIAGRAM PARTS LIST

Model 8826 (1007-20)	3-2
Model 8838F, 9238, 9238F (1011-20A, 1011-20HD)	3-5
Model 9250 (1015-20)	3-6

HYDRAULIC MANIFOLD COMPONENT IDENTIFICATION	3-8
---	-----

HYDRAULIC MANIFOLD PORT IDENTIFICATION	3-8
--	-----

ELECTRICAL SYSTEM

ELECTRICAL SCHEMATIC PARTS LIST - All Models 1997 and Prior

(All Options) (Shown With Kubota Engines and Outrigger Proximity Switches)	3-10
--	------

ELECTRICAL SCHEMATIC - All Models 1997 and Prior

(All Options) (Shown With Kubota Engines and Outrigger Proximity Switches)	3-11
--	------

ELECTRICAL SCHEMATIC - Model 9250 1997 and Since

(All Options) (Shown With Ford Engine and Latest Outrigger Limit Switches)	3-12
--	------

ELECTRICAL SCHEMATIC - All Early Productions Models

(All Options) (Shown With Wisconsin Engine and Outrigger Limit Switches)	3-13
--	------



- 95 3RD SPEED RELAY
- 96 FORWARD DRIVE RELAY
- 97 REVERSE DRIVE RELAY
- 98 RIGHT STEER RELAY
- 99 LEFT STEER RELAY
- 100 OUTRIGGER PUMP RELAY
- 101 LEFT FRONT UP
OUTRIGGER SOLENOID
- 102
- 103 LEFT FRONT DOWN
OUTRIGGER SOLENOID
- 104
- 105 RIGHT FRONT UP
OUTRIGGER SOLENOID
- 106
- 107 RIGHT FRONT DOWN
OUTRIGGER SOLENOID
- 108
- 109 RIGHT REAR UP
OUTRIGGER SOLENOID
- 110
- 111 RIGHT REAR DOWN
OUTRIGGER SOLENOID
- 112
- 113 LEFT REAR UP
OUTRIGGER SOLENOID
- 114
- 115 LEFT REAR DOWN
OUTRIGGER SOLENOID
- 116
- 117
- 118
- 119
- 120
- 121
- 122
- 123

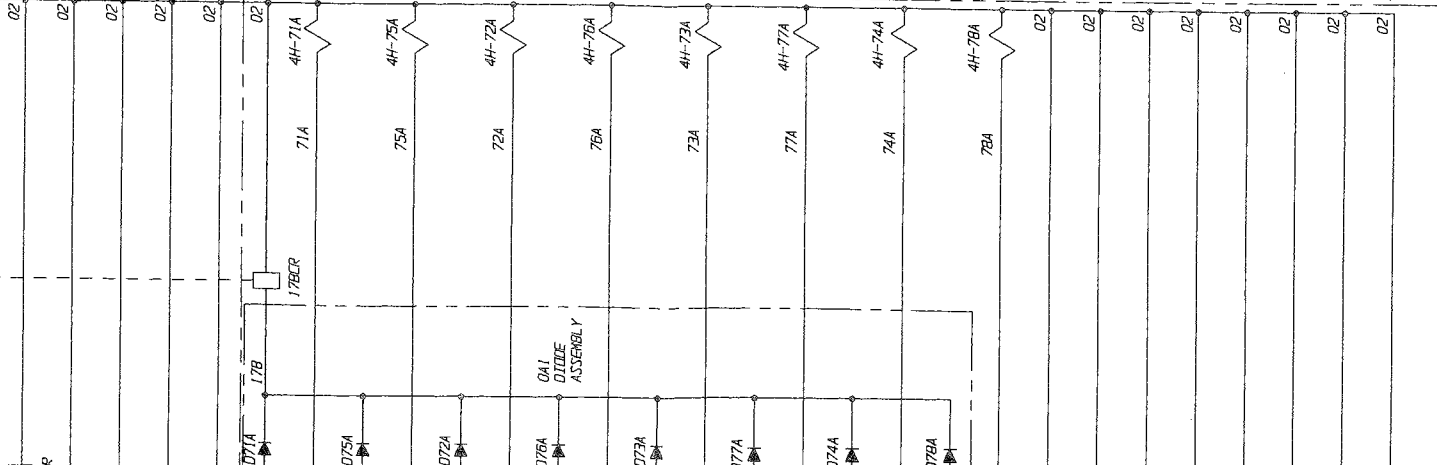

- 31 MAIN LOWERING VALVE SOLENOID
- 32 CYLINDER VALVE SOLENOID
- 33 CYLINDER VALVE SOLENOID
- 34 CYLINDER VALVE SOLENOID
- 35 CYLINDER VALVE SOLENOID
- 36 HORN RELAY
- 37 HORN
- 38 FLASHING LIGHT OPTION
- 39 BEEPER
- 40
- 41 TILT SW. RELAY
- 42 FREE-WHEELING VALVE SOLENOID
- 43 BRAKE DUMP VALVE SOLENOID
- 44 BRAKE FEED VALVE SOLENOID
- 45 ENGINE ON RELAY
- 46 CHOKE RELAY
- 47
- 48
- 49
- 50 START RELAY
- 51 THROTTLE RELAY
- 52
- 53 DOWN RELAY
- 54
- 55 HYD. GENERATOR FAN
- 56 UP RELAY
- 57 HYD. GENERATOR SOLENOID
- 58 HYD. GENERATOR RELAY
- 59 SMALL PUMP RELAY
- 60 LARGE PUMP DUMP VALVE SOLENOID
- 61

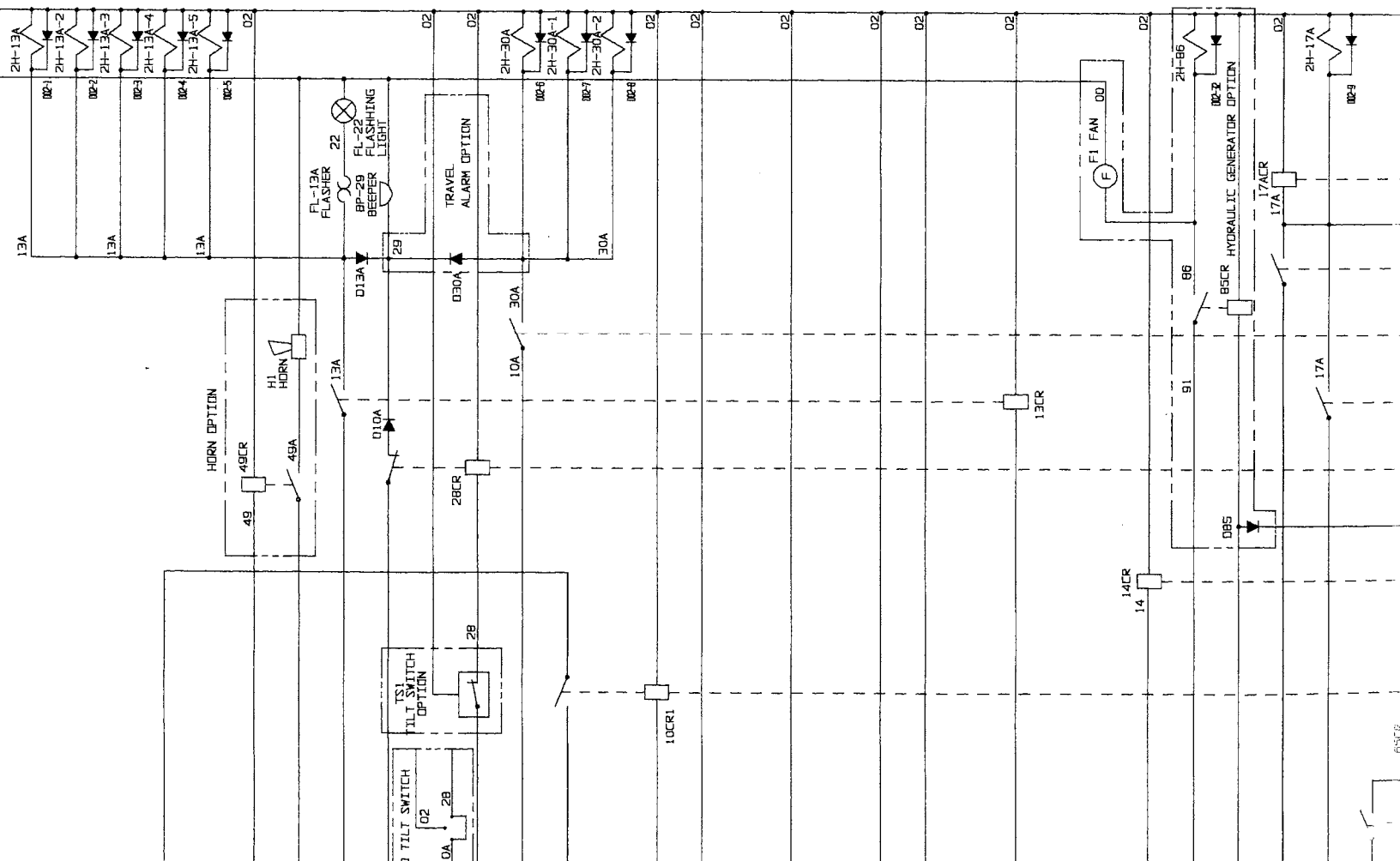

S1
EMERGENCY
STOP SWITCH

CONTROL BOX

BASE

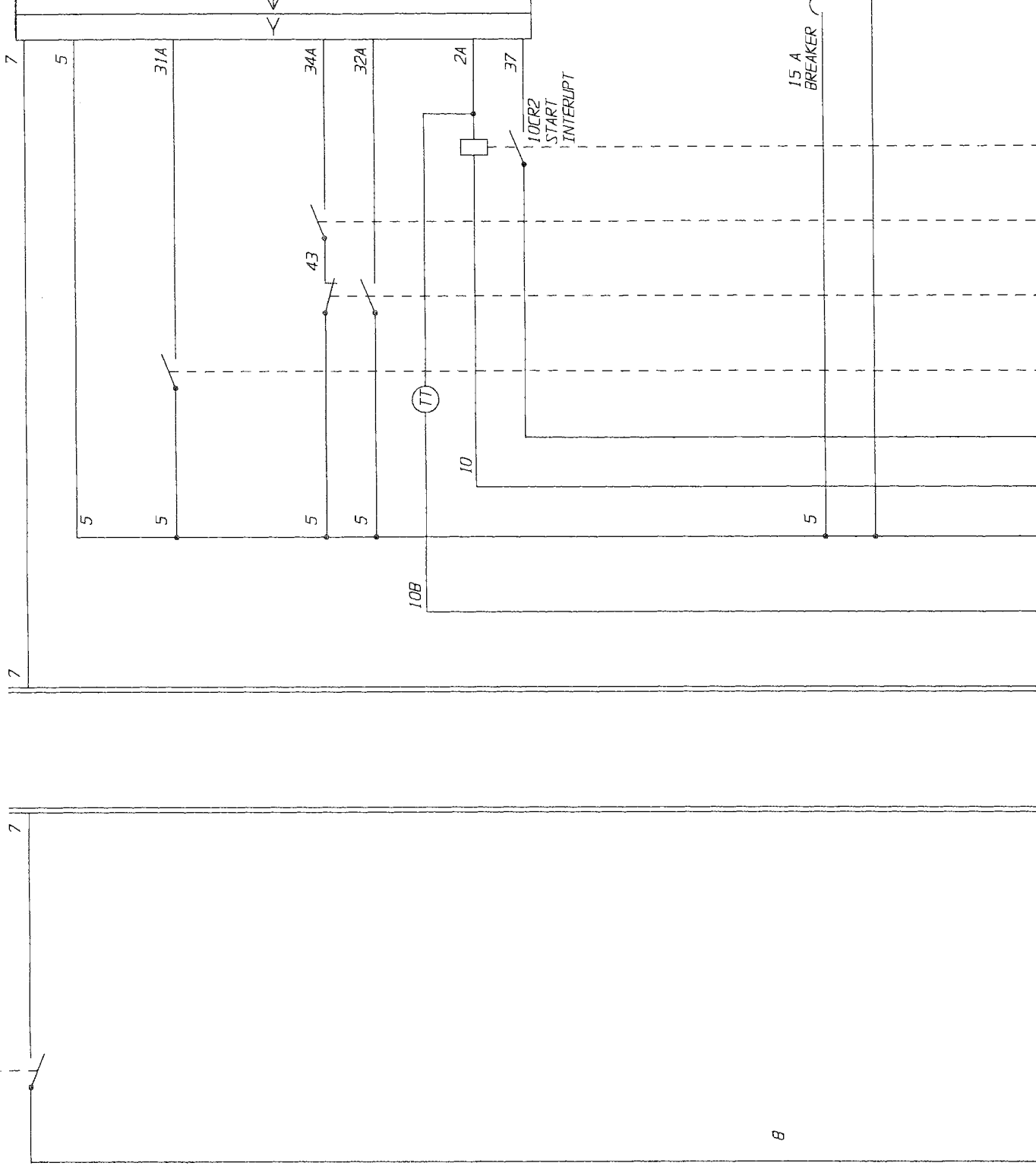

CLICK HERE TO **DOWNLOAD** THE COMPLETE MANUAL

- Thank you very much for reading the preview of the manual.
- You can download the complete manual from: www.heydownloads.com by clicking the link below



- Please note: If there is no response to CLICKING the link, please download this PDF first and then click on it.

CLICK HERE TO **DOWNLOAD** THE COMPLETE MANUAL

TROUBLESHOOTING INFORMATION (Cont.)

TROUBLE	PROBABLE CAUSE	REMEDY
---------	----------------	--------

ELECTRICAL SYSTEM (cont.)

<p>Up Circuit Inoperative</p>	<ol style="list-style-type: none"> 1. Base Up Switch (S16) or Platform Lift/Drive Select Switch (S2) defective. 2. Up Relay (14CR) open or shorted. 3. Up solenoid valve coil (4H14B) open or shorted. 4. Lift Cut-out Switch (S17) defective. 5. Diode (D14B) open or shorted. 6. Broken or loose #14 wire in scissors control cable. 7. Control Box Up Switch (S5) defective. 8. Tilt Alarm Relay (28CR) open or shorted. 9. Tilt Switch defective. 10. One or more outrigger switches (S21, S22, S23, S24) not actuated. (If equipped with Hydraulic Outrigger Option. 11. Large Pump Dump Valve Coil (2H17A) open or shorted. 	<ol style="list-style-type: none"> 1. Check continuity thru switch, replace if defective. 2. Check continuity thru relay, replace if defective. 3. Check coil continuity, replace if defective. 4. Check continuity thru switch, replace if defective. 5. Check and replace if defective. 6. Check continuity, replace if defective. 7. Check continuity in switch, replace if defective. 8. Check continuity thru relay, replace if defective. 9. Replace tilt switch. 10. Extend outriggers and level the work platform. 11. Check coil continuity, replace if defective.
<p>Down Circuit Inoperative</p>	<ol style="list-style-type: none"> 1. Base Down Switch (S15) or Platform Lift/Drive Switch (S2) defective. 2. Broken or loose #13 wire in scissors control cable. 3. Down solenoid valve coil (2H13A, 2H13B, 2H13C, 2H13D or 2H13E) open or shorted. 4. Control Box Down Switch (S5) defective. 	<ol style="list-style-type: none"> 1. Check continuity thru switch, replace if defective. 2. Check continuity, replace if open. 3. Check coil continuity, replace if defective. 4. Check continuity in switches, replace if defective.
<p>Right Steering Inoperative</p>	<ol style="list-style-type: none"> 1. Right steer switch defective. 2. Right steer relay (23CR) open or shorted. 	<ol style="list-style-type: none"> 1. Check continuity thru switch, replace if defective. 2. Check continuity thru relay, replace if defective.

LIST OF ILLUSTRATIONS

(CONTINUED)

Description	
HYDRAULIC/ELECTRIC SIDE CABINET ASSEMBLY	5-40
HYDRAULIC OIL TANK ASSEMBLY	5-42
BASE CONTROL AND ELECTRICAL PANEL ASSEMBLY	5-43
MAIN MANIFOLD ASSEMBLY	5-44
OUTRIGGER LEG ASSEMBLY	5-46
OUTRIGGER CYLINDER ASSEMBLY	5-47
HYDRAULIC HOSE CONNECTIONS - OUTRIGGER	5-48
FRONT OUTRIGGER MANIFOLD ASSEMBLY	5-50
REAR OUTRIGGER MANIFOLD ASSEMBLY	5-51
AC OUTLET ON PLATFORM	5-52
LABELS AND NAMEPLATES	5-55

CONTROL BOX ASSEMBLY
(Machines Without Outriggers)

REF. NO.	PART NUMBER	DESCRIPTION	REF. NO.	PART NUMBER	DESCRIPTION
A	109169	BOX ASSY., Standard control (1) (Machines with round control cable connector)	11	(Ref.) 100149	SWITCH ASSY., Key select (1) WASHER, Flat (1)
B	106131	BOX ASSY., Standard control (1) (Machines with rectangular control cable connector)		102753	HEAD, Key switch (1)
C	109242	BOX ASSY., International control (1) (Machines with round control cable connector)		103100	BASE, Contact (1)
1	108699	WELDMENT, Control box (1) (Replaces 100892)	12	104466	KEY, #455 (1)
2	108703	COVER, Control box bottom (1) (Replaces 101722)		103141	BLOCK, N.O. Contact (1)
	104607	SCREW, Self-tap #6 x 3/4" lg. (9)		103225	BLOCK, N.C. Contact (3)
3	103334	CONTROLLER ASSEMBLY (1) (PQ#M120-728) (For components, refer to Controller Assy.)	12	103080	LABEL, Indicator light, A, B (1)
	103957	SCREW, Mach #8-32 x 1/2" lg. (4)		108331	LABEL, Indicator light, C (1)
4	(Ref.)	LIGHT ASSY., Power indicator (1)	13	102658	LABEL, Throttle switch, A, B (1)
	103202	LENS, Red (1)		108332	LABEL, Throttle switch, C (1)
	102671	BASE, Indicator light (1)	14	102657	LABEL, Up/down switch, A, B (1)
	103221	BULB, 12 Volt (1)		108328	LABEL, Up/down switch, C (1)
5	(Ref.)	SWITCH ASSY., Throttle (1)	15	102627	LABEL, Emergency stop, A, B (1)
	102836	HEAD, Select switch (1)		105351	LABEL, Emergency stop, C (1)
	103100	BASE, Contact (1)	16	103126	LABEL, Key switch, A, B (1)
	103141	BLOCK, N.O. Contact (2)		108335	LABEL, Key switch, C (1)
6	(Ref.)	SWITCH ASSY., Up/down (1)	17	102628	LABEL, Start switch, A, B (1)
	102837	HEAD, Selector switch (1)		108334	LABEL, Start switch, C (1)
	103100	BASE, Contact (1)	18	103060	LABEL, Choke switch (1)
	103141	BLOCK, N.O. Contact (2)		102448	LABEL, Glow plug (1)
7	(Ref.)	SWITCH ASSY., Emerg. stop (1)	19	108855	LABEL, Lift enable (1) (Later models)
	100149	WASHER, Flat (1)	20	(Ref.)	SWITCH ASSY., Lift enable (1) (Later models)
	102769	HEAD, Stop switch (1)		108854	HEAD, Green pushbutton switch (1)
	103100	BASE, Contact (1)		103100	BASE, Contact (1)
	103225	BLOCK, N.C. Contact (1)		103141	BLOCK, N.O. Contact (1)
8	103011	BLOCK, 12 Terminal (1-1/4)	21	102467	LABEL, Horn (1) (Option)
9	(Ref.)	SWITCH ASSY., Choke (1)	22	(Ref.)	SWITCH ASSY., Horn (1) (Option)
	102851	HEAD, Pushbutton switch (1)		102851	HEAD, Pushbutton switch (1)
	103100	BASE, Contact (1)		103100	BASE, Contact (1)
	103141	BLOCK, N.O. Contact (1)	23	103141	BLOCK, N.O. Contact (1)
10	(Ref.)	SWITCH ASSY., Start (1)		109140	CABLE ASSY., Control, A, C (1)
	102851	HEAD, Pushbutton switch (1)		108298	CABLE, 22/25 x 65" lg. (1)
	103100	BASE, Contact (1)		108184	CONNECTOR, 25P male (1) (Consists of:)
	103141	BLOCK, N.O. Contact (1)		108175	HOUSING, Connector (1)
				108176	STRAIN RELIEF (1)
				108180	PIN, Male 22ga. (25)
				(Ref.)	CABLE ASSY., Control, B (1)
				102924	HOUSING, Insert (1)
				102603	INSERT, 24 Pin (1)
				102887	CABLE, 16/25 x 65" lg. (1)
			24	106704	LABEL, Operator warning (1)
			25	102956	PLUG, 7/8" Hole (as req'd)
			26	103268	GRIP, Cable 1" (1)

HYDRAULIC HOSE CONNECTIONS - Scissors (Model 9250)

REF. NO.	PART NUMBER	DESCRIPTION	REF. NO.	PART NUMBER	DESCRIPTION
1	106359	CYLINDER ASSEMBLY , Lift (Replaces 104141) (4) (For components, refer to Page 5-30A.)	8	114582	FITTING , Elbow 90° #6orb-#8 (1)
			9	110475	HOSE ASSEMBLY , Lift manifold to lowering valve manifold (1)
			10	113556	VALVE ASSEMBLY , Controlled lowering (1)
2	114578	FITTING , Elbow 90° #6orb-#6 (4)	11	113494	BLOCK , Controlled lowering valve manifold (1)
3	110666	BLOCK , Lift manifold (2) (Later mach. with o-ring boss ports)	12	114583	FITTING , Elbow 90° #8orb-#8 (Replaces 105447) (2)
	101715	BLOCK , Lift manifold (2) (Early machines with pipe thread ports)	13	113496	SPACER , Orifice (1)
	103861	● BOLT , Hex-hd 1/4-20 x 2" lg. (4)	14	108721	ORIFICE , Controlled lowering .180 diameter (1)
	104000	● WASHER , Lock 1/4" (4)	15	110473	HOSE ASSEMBLY , Lift block to main manifold (1)
4	104437	PLUG , Soc-hd #6 (3)	16	103069	FITTING , Connector #6orb-#6 (6)
6	102562	HOSE ASSY. , Lift block. to lift cylinder (4)			
7	102673	HOSE ASSEMBLY , Lower lift block to upper lift block (1)			

LIFT CYLINDER ASSEMBLY

REF. NO.	PART NUMBER	DESCRIPTION	REF. NO.	PART NUMBER	DESCRIPTION
A	106357	CYLINDER ASSY., Lower lift (2) (Models 8826, 8838F, 9238 & 9238F) (Replaces 104137)	11	106348	PISTON, A, B, C (1)
				104357	PISTON, D, E, F (1)
			12	106344	SPACER, 1/2" thk., A, D (1) (Replaces 104365)
B	106358	CYLINDER ASSY., Upper lift (1) (Models 8838F, 9238 & 9238F) (Replaces 104140)		106345	SPACER, 6-3/4" thk., B, E (1) (Replaces 104359)
				106346	SPACER, 2-3/8" thk., C, F (1) (Replaces 104363)
C	106359	CYLINDER ASSY., Lift (4) (Model 9250) (Replaces 104141)	13	108035	BREATHER VENT, A, B, C (1) (Later models)
D	104137	CYLINDER ASSY., Lower lift (2) (Models 8826, 8838F, 9238 and 9238F) (Order 106357)		103755	KIT, Seal repair (1)
E	104140	CYLINDER ASSY., Upper lift (1) (Models 8838F, 9238 & 9238F) (Order 106358)	* Part of Seal Repair Kit, 103755.		
F	104141	CYLINDER ASSY., Lift (4) (Model 9250) (Order 106359)	Items 14 thru 21 are not included in Cylinder Assembly. Quantities are per lift cylinder.		
			14	103216	BUSHING, Pivot (4)
			15	105501	ORIFICE, Lift .081 dia. (1)
1	107288	HOUSING, Cylinder, A, B, C (1)	16	110668	BLOCK, Valve manifold (1) (Later models with (2) lowering valves)
	104356	HOUSING, Cylinder, D, E, F (1)			
2	106350	ROD, Piston, A, B, C (1)	17	111643	VALVE, Lift cyl. relief (1) (Replaces 104534)
	104358	ROD, Piston, D, E, F (1)			
*3	106282	WIPER, Rod (1)	18	103655	VALVE, N.C. (holding) (AR)
*4	105691	O-RING, Front gland (1)	19	103613	COIL, 12 Volt (AR)
*5	106340	SEAL, Piston (1)	20	103403	O-RING, Manifold seal (1)
*6	106341	RING, Piston wear (1)	21	103402	BLOCK, Valve manifold (1) (Replaces 103401) (Early models with (1) Lowering valve)
*7	103828	O-RING, Piston (1)			
8	106349	GLAND, Front, A, B, C (1)			
	104360	GLAND, Front, D, E, F (1)			
9	106230	NUT, Lock 1-1/4-12 (1)			
10	106347	SPACER, Urethane (1) (Replaces 106342)			

DRIVE BOX ASSEMBLY

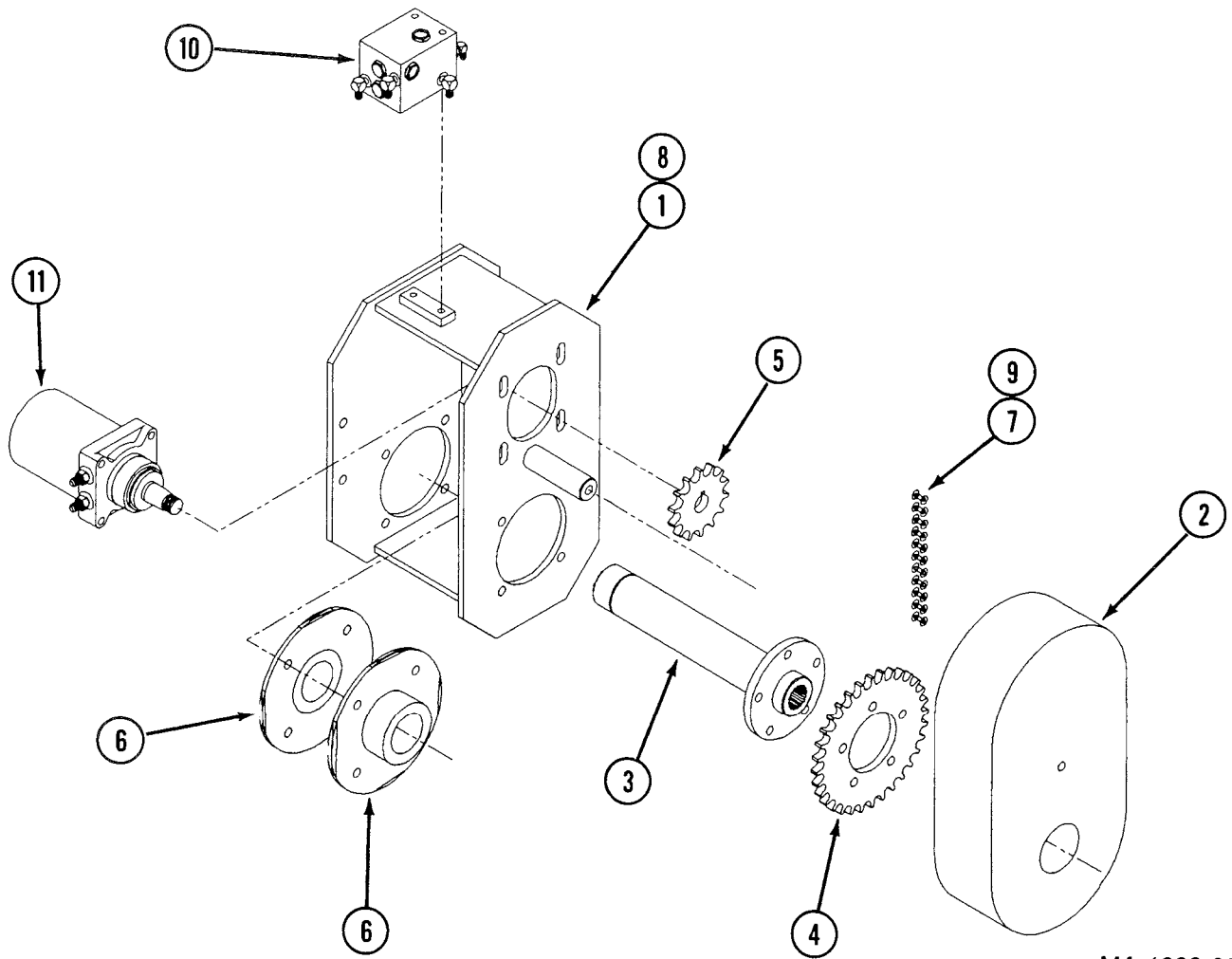

MA-1000-09

REF. NO.	PART NUMBER	DESCRIPTION	REF. NO.	PART NUMBER	DESCRIPTION
1	101958	WELDMENT, Drive box (1)	7	103053	CHAIN, #60 Roller (1)
2	101964	GUARD, Drive chain (1)	8	102971	BRACKET (2)
3	101967	SHAFT, Center drive (1) (For 2WD machines)	9	102970	LINK, Connecting (1)
	101973	SHAFT, Center drive (1) (For 4WD machines)	10	102895	MOTION CONTROL ASSY. (1) (Refer to Hydraulic Hose Connections - Base)
4	101593	SPROCKET, Driven (1) (Replaces 103212)	11	(Ref.)	MOTOR, Hydraulic (1) (Refer to Hydraulic Hose Connections - Base)
5	101714	SPROCKET, Drive (1) (Replaces 103564)			
6	103016	BEARING, Flanged (2)			
	103902	BOLT, Hex-hd 1/2-13 x 2-1/4" lg. (8)			
	103468	WASHER, Flat 1/2" (8)			
	103471	NUT, Hex 1/2-13 (8)			

MAIN MANIFOLD ASSEMBLY

REF. NO.	PART NUMBER	DESCRIPTION	REF. NO.	PART NUMBER	DESCRIPTION
A	114384	MANIFOLD ASSY., Main (Later machines with #10 Large Pump Dump Valve)	17	105447	FITTING, Elbow 90° #8orb-#8, A (1)
				103069	FITTING, Connector #6orb-#6, B (1)
				103323	FITTING, Connector 3/8P-#6, C (1)
B	108831	MANIFOLD ASSY., Main (Early machines with #8 Large Pump Dump Valve and o-ring boss ports)	18	105447	FITTING, Elbow 90° #8orb-#8 A, B (1)
				103325	FITTING, Elbow 90° 3/8P-#6, C (1)
			19	102930	FITTING, Plug 1/16P, C (9)
C	§	MANIFOLD ASSY., Main (Early machines with #8 Large Pump Dump Valve and pipe thread ports)	20	102659	FITTING, Connector #8orb-#8, A (2)
				103070	FITTING, Connector #8orb-#6, B (2)
				103323	FITTING, Connector 3/8P-#6, C (2)
1	114178	BLOCK, Main manifold, A (1)			
	108009	BLOCK, Main manifold, B (1)			
2	101764	BLOCK, main manifold, C (1)	22	116128	FITTING, Tee #8orb-#8-1/4P, A (1)
	103397	VALVE ASSY., 12V spool (steer) (1)		114520	QUICK DISCONNECT, 1/4P (1)
3	107440	COIL, 12 Volt (2) (Vickers)		114521	DUST CAP, Quick disconnect (1)
	103691	COIL, 12 Volt (2) (Rexroth)		102659	FITTING, Connector #8orb-#8, B (1)
	103345	COIL, 12 Volt (2) (Abex)		101450	FITTING, Connector w/orifice, B (1) (Machines with 2-speed lowering)
	104345	CONNECTOR, Gray (1)		106668	FITTING, Connector 3/8P-#8, C (1)
	104409	CONNECTOR, Black (1)	23	103073	FITTING, Elbow 90° #6orb-#6 A, B (1) (Machines with outriggers)
	103920	BOLT, Soc-hd #10-24 x 2" lg. (4)		103324	FITTING, Elbow 90° 1/4P-#6, C (1) (Machines with outriggers)
	103396	VALVE ASSY., 12V spool (drive) (1)	24	103069	FITTING, Connector #6orb-#6 A, B (1) (Machines with outriggers)
	107441	COIL, 12 Volt (2) (Vickers)		103322	FITTING, Connector 1/4P-#6, C (1)
	104097	COIL, 12 Volt (2) (Rexroth)	25	108747	HARNNESS, Manifold wiring (1) (not shown) (Replaces 104648)
	107442	COIL, 12 Volt (2) (Abex)			
104345	CONNECTOR, Gray (1)				
104409	CONNECTOR, Black (1)				
103943	BOLT, Soc-hd 1/4-20 x 2" lg. (4)				
4	103655	VALVE, #8 N.C. (brake dump) (1)			
5	103655	VALVE, #8 N.C. (lift) (1)			
6	103655	VALVE, #8 N.C. (lowering) (1)			
7	103656	VALVE, #8 N.O. (brake feed) (1)			
8	103656	VALVE, #8 N.O. (small pump dump) (1)	26	104437	PLUG, Manifold #6orb (1)
9	103656	VALVE, #8 N.O. (large pump dump) B, C (1)	27	109696	BLOCK, 2-Speed lowering manifold (1)
10	103613	COIL, 12 Volt (AR)	28	103655	VALVE, #8 N.C. (1)
11	104534	VALVE, Relief (2)	29	110708	FITTING, Swivel #8orb-#8 (1)
12	104624	VALVE, Pilot check (3)	30	102659	FITTING, Connector #8orb-#8 (1)
13	104630	ORIFICE, Lowering .096 dia (1)	31	100060	ORIFICE, 2-Speed lowering .055 diameter (1)
14	112187	FITTING, Hose barb #12orb-3/4B A, B (1)	32	114365	VALVE, #10 N.O. (large pump dump) A (1)
	103294	FITTING, Hose barb 1/2P x 3/4B C (1)	33	106272	COIL, 12 Volt, A (1)
15	102659	FITTING, Connector #8orb-#8, A (1)	34	114518	FITTING, Elbow 90° #6orb-1/4P A (1)
	103073	FITTING, Elbow 90° #6orb-#6, B (1)		114520	QUICK DISCONNECT, 1/4P (1)
	103324	FITTING, Elbow 90° 1/4P-#6, C (1)		114521	DUST CAP, Quick disconnect (1)
16	103069	FITTING, Connector #6orb-#6 A, B (3)			
	103322	FITTING, Connector 1/4P-#6, C (3)			

Items 26 - 31 are for machines equipped with 2-speed lowering manifold.

§ - Not available for service.

CLICK HERE TO **DOWNLOAD** THE COMPLETE MANUAL

- Thank you very much for reading the preview of the manual.
- You can download the complete manual from: www.heydownloads.com by clicking the link below



- Please note: If there is no response to CLICKING the link, please download this PDF first and then click on it.

CLICK HERE TO **DOWNLOAD** THE COMPLETE MANUAL